

# CGE High Power Connectors



Contents

Introduction ..... 2  
 Connector Design ..... 2  
 How to order ..... 3  
 Mateability ..... 3  
 Polarization ..... 3  
 Technical Data ..... 4  
 Panel Cut-Outs ..... 5  
 Connector Dimensions ..... 6  
 Accessories ..... 9  
 Contacts and Tools ..... 10  
 Product Safety Information ..... 11

Introduction

The Cannon CGE connectors are designed to transmit very high current at low voltage, as for example in the electrical equipment of military land- and sea-borne vehicles and in industrial applications. The connectors meet the mating dimensions, mechanical features and rear panel installation requirements of VG 95234. Ultraflexible shielded welding cables acc to MTV 6145-005 are terminated to the connectors.

The contacts made of copper or a copper alloy with hard silver finish are designed for crimping or termination to solid copper conductors with threaded bolts. The mechanical durability is a minimum of 500 mating cycles. The crimp contacts accept wires according to DIN 46438 (25 – 240 mm<sup>2</sup>). Contact retention is achieved by the two-piece insulator which is fixed to the shell with a snap-in ring. This allows unlimited exchange of the crimp contacts.

The bayonet coupling assures fast and reliable mating and unmating. Audible snap-in and colour-coded snap-in points indicate positive mating. Plugs and receptacles are waterproof in mated condition up to 1 bar (35 feet of water).

Connector Design

The high power connectors CGE feature one contact in a two-piece rigid insulator. The aluminum shell has a chromate finish over cadmium. The operating temperature ranges from -55 to 125°C.

Connector Design

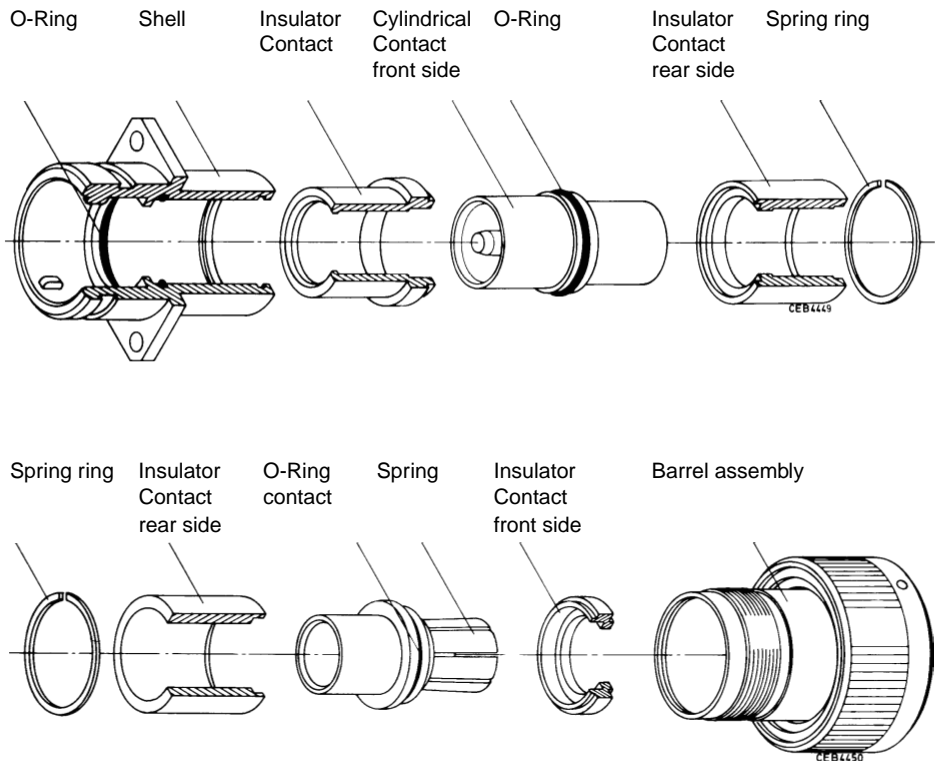

**Polarization**

To avoid mismatching of identic connectors the keyways of CGE connectors are available in two different positions:

Standard position = 180°  
 Position W = 120°

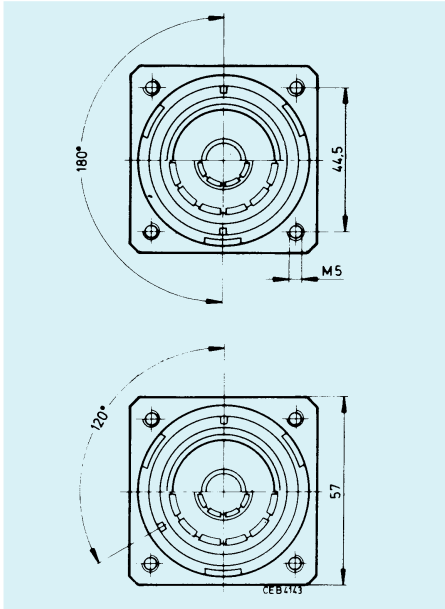

Keyway positions of receptacles and cable connecting plugs

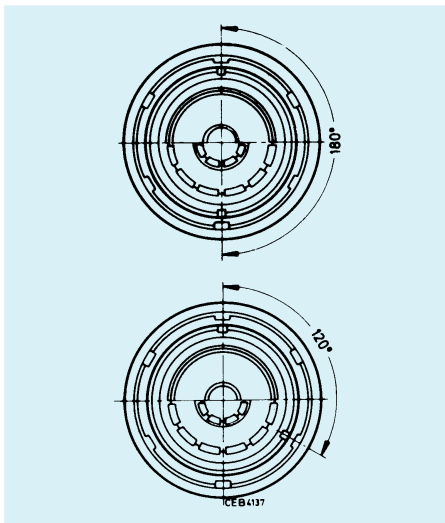

Keyway positions of straight and 90° plugs

**How to order**

CGE 6 E 32 H 24 F W B \*

Series \_\_\_\_\_  
 Cannon Designation

Shell style \_\_\_\_\_  
 0 - wall mounting receptacle with flange  
 1 - cable connecting plug  
 2 - box mounting receptacle with flange  
 6 - straight plug  
 8 - plug 90°  
 9 - bulkhead

Class \_\_\_\_\_  
 E - environmental, JP07 acc to DIN 40050

Shell size \_\_\_\_\_  
 16 - 18 - 22 - 28 - 32

Contact arrangement \_\_\_\_\_  
 16H2 - shell size 16, 1 contact H2  
 18H5 - shell size 18, 1 contact H5  
 22H9 - shell size 22, 1 contact H9  
 28H15 - shell size 28, 1 contact H15  
 32H24 - shell size 32, 1 contact H24

Contact size \_\_\_\_\_  
 H2 - 25 mm<sup>2</sup>  
 H5 - 50 mm<sup>2</sup>  
 H15 - 150 mm<sup>2</sup>  
 H24 - 240 mm<sup>2</sup>

Contact type \_\_\_\_\_  
 F - spring contact  
 Z - cylindrical contact

Keyway polarization \_\_\_\_\_  
 W - 120°

Bayonet coupling \_\_\_\_\_

Modification \_\_\_\_\_  
 05 - through-holes in flange  
 03 - adapter for heat shrink boots, metric crimp contact  
 04 - rear panel mounting, threaded holes, metric crimp contact  
 04-05 - same as -04, however, with through-holes  
 14 - shielded version, metric crimp contact  
 16 - thread bolt termination, front panel mounting, O ring for sealing between wall and receptacle (for CGE2EB only)

**Mateability**

Receptacles and cable connecting plugs mate with	→	Plugs, straight / 90°
CGE2E-B04, CGE-B-04-05		CGE6E-B-03
CGE2E-B-16		CGE6E-B-14
CGE0E-B-03, CGE-B-05-05		CGE8E-B-03
CGE1E-B-03		CGE8E-B-14

Technical Data

**Admissible ambient temperature**  
-55/125°C

**Class**  
JP07 acc to DIN 40050

**Test pressure**  
1 bar overpressure

**Test duration**  
12 h

**Vibration**  
200 m/s<sup>2</sup> for 10 – 2000 Hz

**Mechanical durability**  
500 mating cycles

**Coupling torque**  
in wired condition acc to VG95319, Part 2, Test No 5.8.2.

Shell size	max closing / opening Nm	max opening Nm
16	5,5	0,5
18	8,0	0,6
22	11,0	0,8
28	17,0	0,9
32	19,0	1,0

**Contact retention**  
acc to VG 95319, Part 2, Test No 5.4.

Contact size	Test force N min
H2	100
H5	120
H9	140
H15	160
H24	200

Materials

Shell	Aluminum alloy
- Finish	Olive chromate over cadmium
Insulator	PTFE
Contact	Copper or copper alloy
- Finish	Hard silver
O ring	FKM

Electrical Data

**Current rating**  
(A) at 125°C ambient temperature

Shell size	16	18	22	28	32
Contact size	H2	H5	H9	H15	H24
Max Current rating (A)	225	350	570	750	950
Max Short-time load, appr 0,5 – 1 sec (A)	750	1000	2000	3000	5000

**Air and creepage paths**  
Air path 3 mm min  
Creepage path 5 mm min

**Insulator resistance**  
min 5000 MOhm

**Contact resistance**  
(mOhm max)

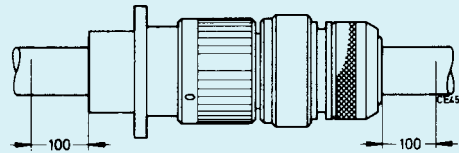

Contact size	H2	H5	H9	H15	H24
Contact resistance	0,6	0,3	0,15	0,1	0,07

Cables

The connectors are designed for ultraflexible welding cable acc to MTV 6145-005.

Shell size	Wire size	MTV 6145-005 designation	
		shielded	unshielded
16	25	MTV 6145-005 H001	MTV 6145-005 G001
18	50	MTV 6145-005 H002	MTV 6145-005 G002
22	95	MTV 6145-005 H003	MTV 6145-005 G003
28	150	MTV 6145-005 H004	MTV 6145-005 G004
32	240	MTV 6145-005 H005	MTV 6145-005 G005

When selecting a cable type please consider self-heating of cable at the maximum operating voltage and the maximum ambient temperature (see page 5).

Cable Data

Approx. values for cable self-heating

Wire size mm <sup>2</sup>	Max admissible operating voltage	Approx over-temperature due to current load: Δ T in °C		
		1/3 of max admissible operating voltage	2/2 of max admissible operating voltage	max admissible operating voltage
25	250	35	52	95
50	300	15	25	55
95	500	10	33	70
150	600	5	23	60
240	1000	8	30	75

Cable Dimensions

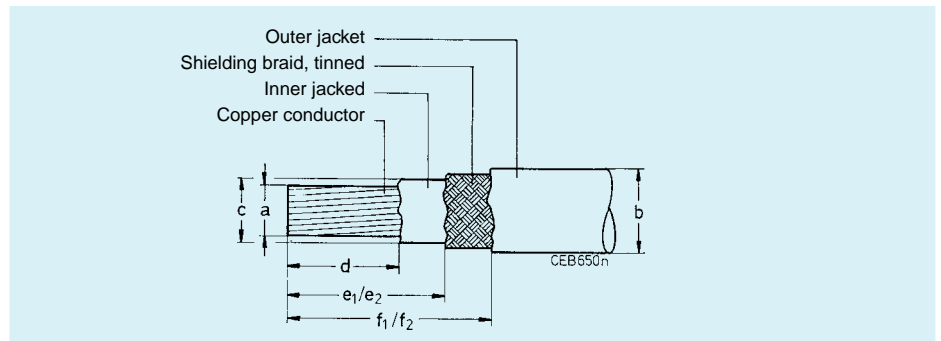

Cable designation	Shell size	Wire size mm <sup>2</sup>	Straight plug							
			a	b max	c max	d <sup>+/-10,5</sup>	e1 <sup>+/-1,0</sup>	f1 <sup>+/-1,0</sup>	e2 <sup>+/-1,0</sup>	f2 <sup>+/-1,0</sup>
MTV6145-005+001	16	25	7,5 <sup>+/-0,5</sup>	13,5	10,2	14,0	31,0	46,0	-	-
MTV6145-005+001	18	50	11,0 <sup>+/-0,5</sup>	18,0	14,3	15,0	31,0	46,0	-	-
MTV6145-005+001	22	95	16,0 <sup>+/-0,5</sup>	23,5	19,7	20,5	42,0	57,0	20,0	35,0
MTV6145-005+001	28	150	20,5 <sup>+/-0,5</sup>	30,0	25,4	30,0	-	-	25,0	40,0
MTV6145-005+001	32	240	26,5 <sup>+/-0,5</sup>	36,0	32,5	30,0	54,0	69,0	25,0	40,0

Panel Cut-Outs

Panel cut-outs for rear and front panel mounting of receptacles

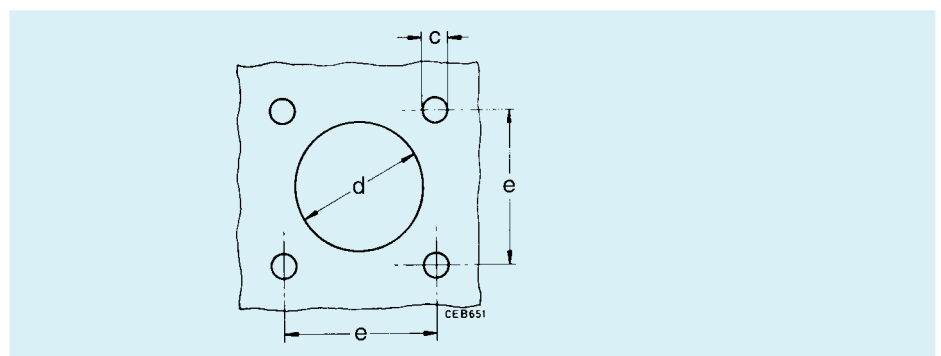

Shell size	Receptacles, rear panel mounting CGE0E-B-03/14 CGE2E-B-04			Receptacles, front panel mounting CGE2E-B-16			
	H13 c <sup>+0,15</sup>	H12 d <sup>+0,15</sup>	d <sup>±0,15</sup>	H13 c	H12 thread	d	c <sup>±0,15</sup>
16	4,5	27,7	24,6	4,5	M4	22,5	24,6
18	4,5	31,1	27,0	4,5	M4	27,4	27,0
22	4,5	37,8	31,8	4,5	M4	33,7	31,8
28	5,5	47,1	39,7	4,5	M4	43,5	39,7
32	5,5	53,8	44,5	4,5	M4	49,7	44,5

CGE0E...B-03

Wall mounting receptacle,  
acc to VG 96929B1,  
rear panel mounting,  
four threaded holes in flange,  
adapter for heat shrink boot,  
metric crimp contacts

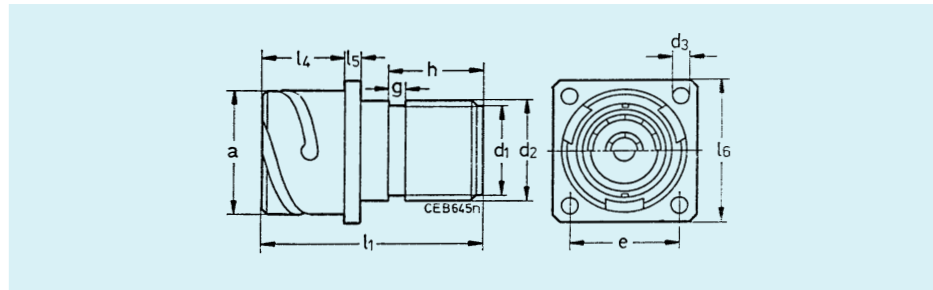

Shell size	a	d <sub>1</sub>	d <sub>2</sub>	d <sub>3</sub>	e	g	h	l <sub>1</sub>	l <sub>4</sub>	l <sub>5</sub>	l <sub>6</sub>
	- 0,15	± 0,15	± 0,3		± 0,1	± 0,1	± 0,2	± 0,3	± 0,3	± 0,15	± 0,3
16	27,4	20,0	22,1	M4	24,6	3,2	12,0	41,0	20,0	3,2	32,5
22	37,4	45,8	49,2	M4	31,8	3,2	20,8	55,0	23,15	4,0	41,0
32	53,4	45,8	49,2	M5	44,5	3,5	28,0	66,8	29,0	4,0	57,0

CGE1E...B-03

Cable connecting plug, straight,  
adapter for heat shrink boots,  
metric crimp contacts

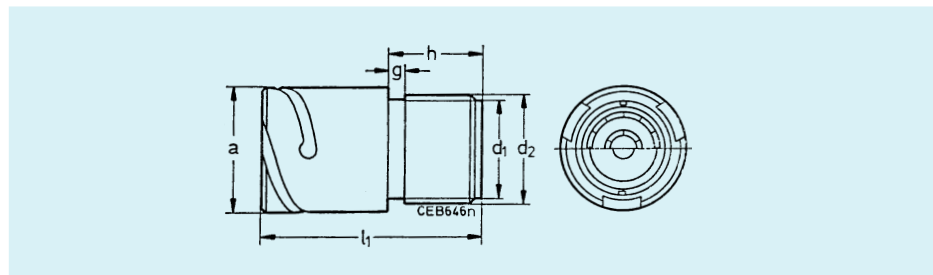

Shell size	a	d <sub>1</sub>	d <sub>2</sub>	g	h	l <sub>1</sub>
	- 0,15	± 0,15	± 0,15	± 0,1	± 0,15	± 0,3
18	30,8	25,0	27,0	3,2	20,0	50,0
22	37,4	31,5	34,9	3,2	20,5	54,0
28	53,4	45,8	50,0	3,5	28,0	66,8
32	46,7	41,0	44,4	3,5	25,0	65,8

CGE1E...B-14

Cable connecting plug,  
shielded version,  
metric crimp contacts

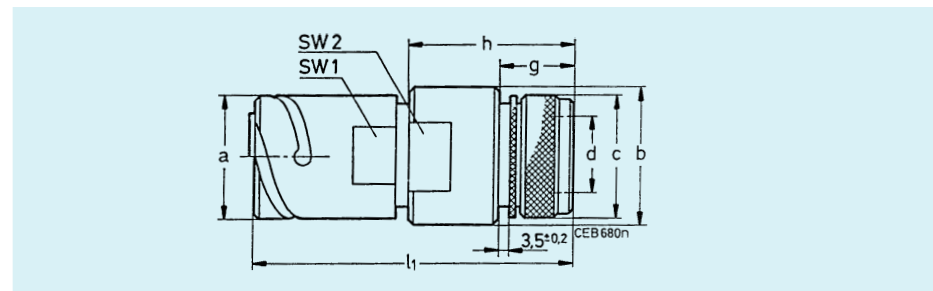

Shell size	a	b	c	d	g	h	l <sub>1</sub>	SW1	SW2
	± 0,15			± 0,3	± 0,2	max	max		
18	37,4	42,0	37,0	25,5	22,5	48,5	95,5	34	38

CGE2E...B-04

CGE2E...B-04-05

Box mounting receptacle,  
rear panel mounting,  
-04 – four threaded holes in flange,  
-04-05 – four through holes in flange

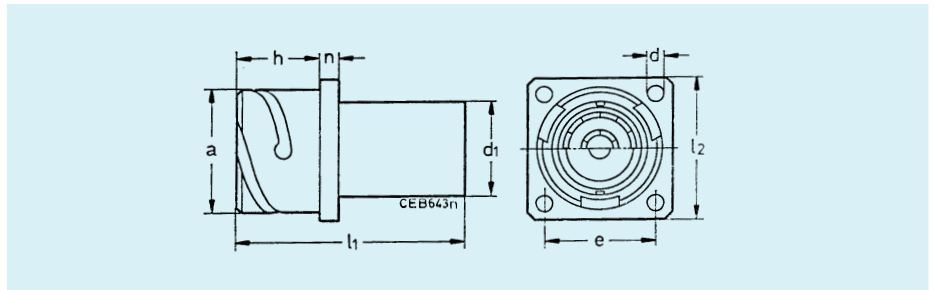

Shell size	a	d <sub>1</sub>	d		e	h	l <sub>1</sub>	l <sub>2</sub>	n
	- 0,15	± 0,15	Mod 04	Mod 05	± 0,1	± 0,2	± 0,3	± 0,3	± 0,1
16	27,4	22,1	M4	4,3	24,6	20,0	41,0	32,5	3,2
18	30,8	27,0	M4	4,3	27,0	23,15	50,0	35,0	4,0
22	37,4	34,9	M4	4,3	31,8	23,15	54,0	41,0	4,0
28	46,6	42,7	M4	4,3	39,7	-	65,3	50,8	4,0
32	53,4	49,2	M5	5,3	44,5	29,0	66,8	57,0	4,0

CGE2E...B-16

Box mounting receptacle,  
front panel mounting,  
four through holes in flange,  
threaded bolt termination for  
solid copper rail

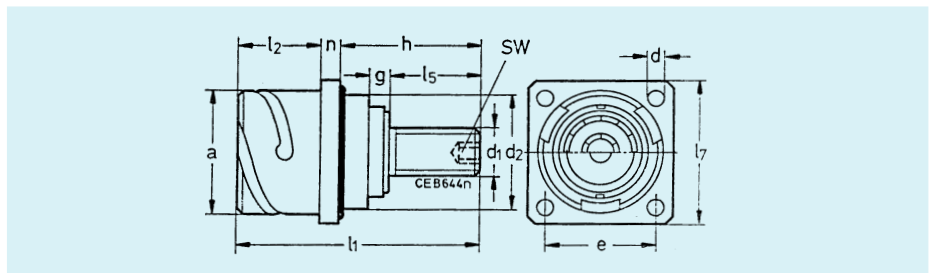

Shell size	a	d <sub>1</sub>	d <sub>2</sub>	d	e	g	h	l <sub>1</sub>	l <sub>2</sub>	l <sub>5</sub>	l <sub>7</sub>	n	SW
	- 0,15		- 0,15	+ 0,2	± 0,1	± 0,3		max	± 0,3	± 0,5	+ 0,3	± 0,15	
18	30,8	M8	26,9	4,3	27,0	4,0	27,5	55,0	23,15	15,0	35,0	4,0	3
22	37,4	M12	33,2	4,3	31,8	4,4	38,0	65,5	23,15	25,3	41,0	4,0	6
28	46,6	M12	42,8	4,3	39,7	4,0	32,0	61,0	24,15	20,0	50,8	4,0	6
32	53,4	M16	49,2	4,3	44,5	6,0	44,5	73,0	29,0	22,0	57,0	4,0	8

CGE6E...B-03

Straight plug  
acc to VG 96929A2,  
adapter for heat shrink boots,  
metric crimp contacts

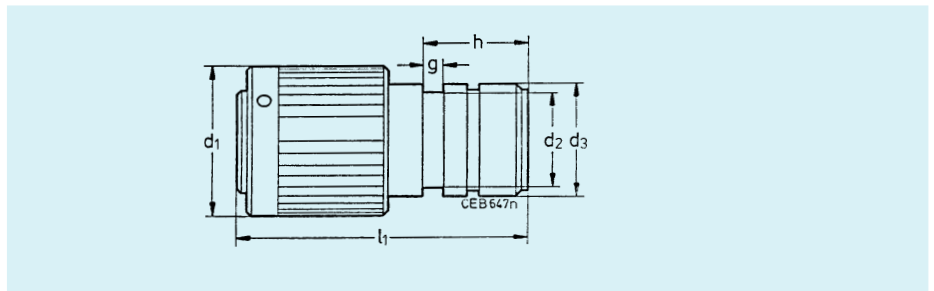

Shell size	d <sub>1</sub>	d <sub>2</sub>	d <sub>3</sub>	g	h	l <sub>1</sub>
	max	- 0,1	max		± 0,2	max
16	32,0	20,2	22,3	4,3	27,0	44,0
18	36,5	25,8	28,0	4,3	31,8	53,0
22	43,1	31,5	35,0	4,3	39,7	57,0
32	60,1	45,4	49,2	4,3	44,5	65,0

**CGE6E...B-14**

**Straight plug**

acc to VG 96929F,  
360° HF shielding by grounding fingers,  
endbells for clamp connection of shielding  
braid and for heat shrink boots,  
metric crimp contacts

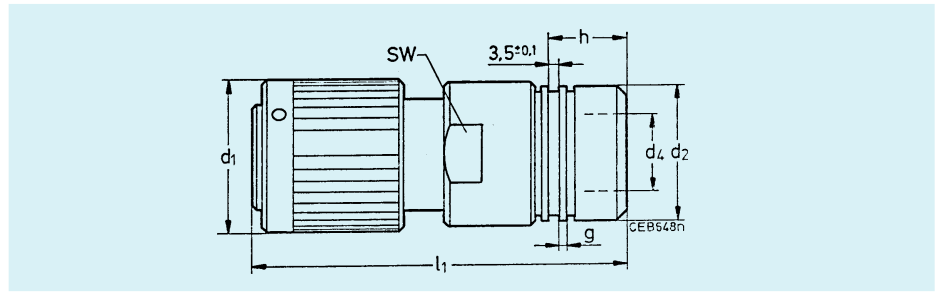

Shell size	c	d <sub>1</sub>	d <sub>2</sub>	d <sub>4</sub>	g	h	l <sub>1</sub>	SW
	± 0,3	max	± 0,15	± 0,1	± 0,1	± 0,4	max	
16	26,0	32,0	24,0	15,5	1,0	25,5	68,0	26
18	32,0	36,5	28,7	20,0	1,0	26,0	73,5	32
22	37,0	43,1	33,7	25,5	1,0	26,0	84,0	38
28	44,0	53,0	40,0	32,0	1,0	26,0	98,0	50
32	31,0	60,1	47,2	38,0	1,0	28,0	95,5	54

**CGE8E...B-03**

**90° plug**

with adapter for heat shrink boots,  
metric crimp contacts

**CGE8E...B-14**

**90° plug**

acc to VG 96929E,  
with grounding fingers, adapter for  
shielding braid and for use with heat  
shrink boots, metric crimp contacts

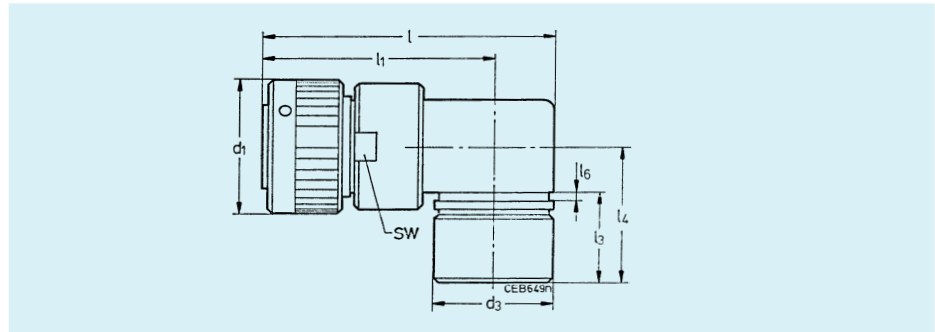

Shell size	d <sub>1</sub>	d <sub>3</sub>	l <sub>1</sub>	l <sub>3</sub>	l <sub>4</sub>	l <sub>6</sub>	l	SW
	max	max	± 1,0	max	max	± 0,2	max	
22	43,1	42,0	80,0	41	56	3,2	101,0	38
28	53,0	48,0	78,0	41	56	3,2	102,0	50
32	60,1	52,5	84,0	41	56	3,2	112,0	52

**CGE9E...X-B-04**

**Bulkhead**

acc to VG 96929C2,  
with through holes in flange

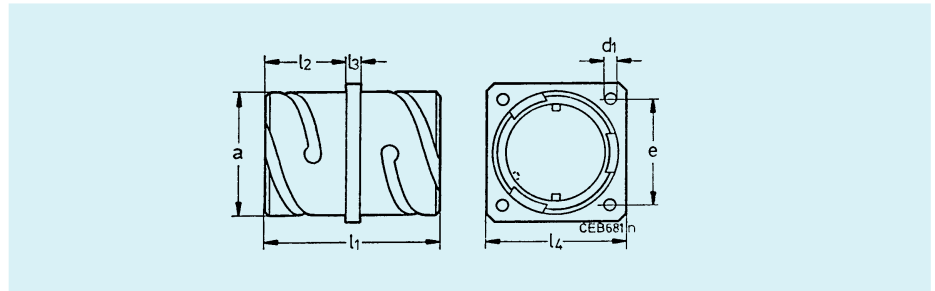

Shell size	a	d <sub>1</sub>	e	l <sub>1</sub>	l <sub>2</sub>	l <sub>3</sub>	l <sub>4</sub>
	- 0,15		± 0,1	max	± 0,3	± 0,1	± 0,3
22	46,7	5,3	39,7	51,5	20,6	4,0	50,8



Accessories

Dust cap 121004  
for plugs

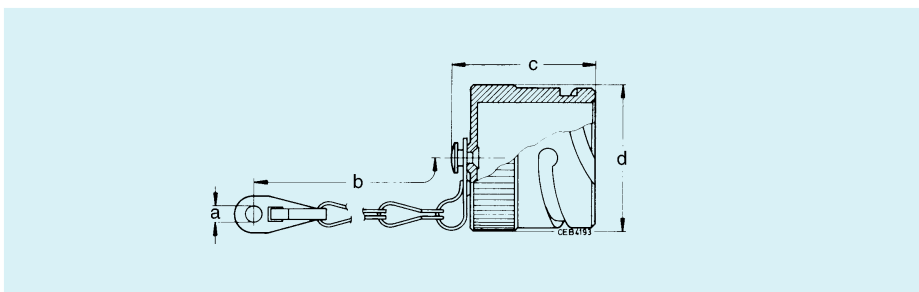

Order reference	Size	a + 0,5	b ± 10,0	c max	d max
CA121004-4	16S	4,3	113	29,0	29,9
CA121004-6	18	4,3	127	30,0	33,3
CA121004-8	22	4,3	140	30,0	39,9
CA121004-10	28	4,3	197	30,0	49,2
CA121004-11	32	5,5	197	30,0	55,9

Dust cap 121003  
for receptacles

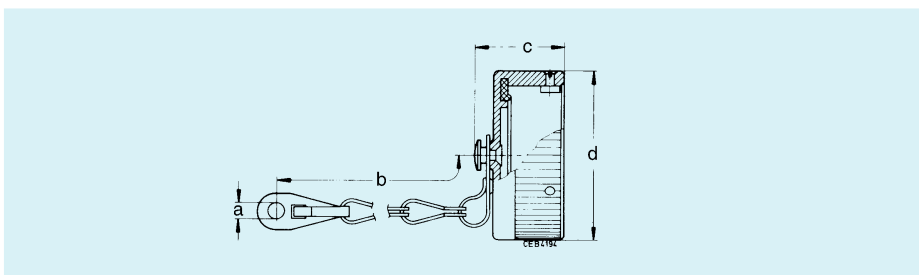

Order reference	Size	a + 0,5	b ± 10,0	c max	d max
CA121003-4	16S	4,3	100	19,5	32,6
CA12100436	18	4,3	113	25,4	36,7
CA121003-8	22	4,3	127	25,4	43,3
CA121003-10	28	5,5	169	25,4	52,6
CA121004311	32	5,5	169	25,4	59,3

Dummy receptacle

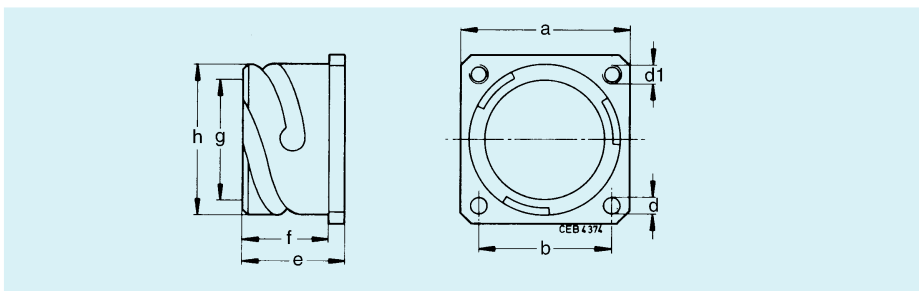

Order ref.	Size	a ± 0,3	b ± 0,15	d + 0,2	d <sub>1</sub>	e ± 0,2	f +0,3 / - 0,1	g + 0,1	h + 0,15
248-8504-000	16S	32,5	24,6	3,2	M4	21,5	18,3	29,6	27,4
248-8506-000	18	35,0	27,0	3,2	M4	27,2	23,15	23,8	30,8
248-8508-000	22	41,0	31,8	3,2	M4	27,2	23,15	30,0	37,4
248-8510-000	28	50,8	39,7	3,7	M5	28,2	24,15	38,8	46,7
248-8511-000	32	57,0	44,5	4,4	M5	28,2	24,15	45,2	53,4

Accessories

Sealing gaskets

for rear panel mounting only

Shell size	Order references Polychloroprene	Order references Alu-Flex (shielded version)
16	075-8504-000	075-8504-001
18	075-8505-000	075-8505-001
22	075-8507-000	075-8507-001
28	075-8509-000	075-8509-001
32	075-8510-000	075-8510-001

O Rings

for sealing of front mounting receptacles are included in shipment

Contacts

Order references for single contacts

Shell size	Spring contact	Cylindrical contact	Contact type	Crimp sleeve
H24	031-8564-000	330-8697-000	Crimp with	
	031-8567-000	330-8696-000	threaded bolt	
	031-8658-000	031-8701-002	for 90° plug	252-8583-000
H15	031-8663-000	330-8719-000	with threaded bolt	
	031-8669-000	031-8701-000	for 90° plug	252-8583-000
	031-8701-004	430-8561-009	Crimp version	
H9	031-8649-000	330-8698-000	Crimp with	
	031-8660-000	330-8695-000	threaded bolt	
	031-8659-000	031-8701-000	for 90° plug	252-8583-000
H5	031-8655-000	330-8710-000	crimp with	
	031-8656-000	330-8712-000	threaded bolt	
H2	031-8616-000	330-8623-000	crimp version	
H9	-	031-8705-000	for bulkhead	

Note: When choosing the contacts please make sure that the voltage carrying side of the connection is quipped with the cylindrical contact.

Crimp Tools

Description	Designation	Order reference
1 Hand pump	4601.00000.330	121586-0027
2 Foot operation for hand pump	4601.51000.330	121586-0008
3 High pressure hose, length 2 m	4604.00000.020	121586-0023
4 Crimp head	4632.00000.601	121586-0031
5 Safety device incl. bench mounting	CT121086-3079	121086-3079
6 Positioner (to be used with 121086-3079 only)	CT121086-3080	121086-3080

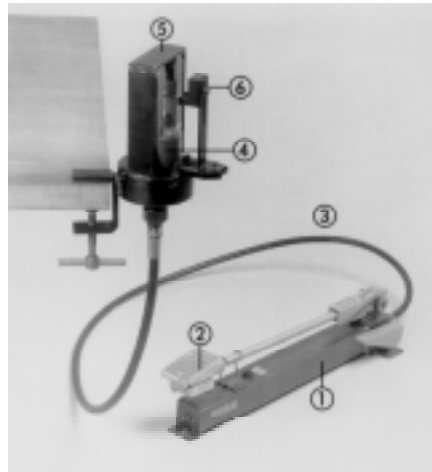

Right hand photograph:  
Electro-hydraulic crimp tool HK12EL.  
Available upon request – please consult factory

Crimp dies

Contact size	Order reference upper crimp dies	Order reference lower crimp dies
H2	317-8578-006	317-8578-007
H5	317-8578-008	317-8578-009
H9	317-8578-004	317-8578-005
H15	317-8578-002	317-8578-003
H24	317-8578-000	317-8578-001

Special Allen Wrenches

for endbell assembly

Shell size	Order reference
16	CGE-SW26
18	CGE-SW26
22	CGE-SW26
28	CGE-SW26

## Product safety Information

**THIS NOTE SHOULD BE READ IN CONJUNCTION WITH THE PRODUCT DATA SHEET/CATALOGUE. FAILURE TO OBSERVE THE ADVICE IN THIS INFORMATION SHEET AND THE OPERATING CONDITIONS SPECIFIED IN THE PRODUCT DATA SHEET/CATALOGUE COULD RESULT IN HAZARDOUS SITUATIONS.**

### 1. MATERIAL CONTENT AND PHYSICAL FORM

Electrical connectors do not usually contain hazardous materials. They contain conducting and non-conducting materials and can be divided into two groups.

a) Printed circuit types and low cost audio types which employ all plastic insulators and casings.

b) Rugged, Fire Barrier and High Reliability types with metal casings and either natural rubber, synthetic rubber, plastic or glass insulating materials.

Contact materials vary with type of connector and also application and are usually manufactured from either copper, copper alloys, nickel, alumel, chromel or steel. In special applications, other alloys may be specified.

### 2. FIRE CHARACTERISTICS AND ELECTRIC SHOCK HAZARD

**There is no fire hazard when the connector is correctly wired and used within the specified parameters. Incorrect wiring or assembly of the connector or careless use of metal tools or conductive fluids, or transit damage to any of the component parts may cause electric shock or burns. Live circuits must not be broken by separating mated connectors as this may cause arcing, ionisation and burning.**

Heat dissipation is greater at maximum resistance in a circuit. Hot spots may occur when resistance is raised locally by damage, e.g. cracked or deformed contacts, broken strands of wire. Local overheating may also result from the use of the incorrect application tools or from poor quality soldering or slack screw terminals. Overheating may occur if the ratings in the Product Data Sheet/Catalogue are exceeded and can cause breakdown of insulation and hence electric shock.

If heating is allowed to continue it intensifies by further increasing the local resistance through loss of temper of spring contacts, formation of oxide film on contacts and wires, and leakage currents through carbonisation of insulation and tracking paths. Fire can then result in the presence of combustible materials and this may release noxious fumes. Overheating may not be visually apparent. Burns may result from touching overheated components.

### 3. HANDLING

Care must be taken to avoid damage to any component parts of electrical connectors during installation and use. Although there are normally no sharp edges, care must be taken when handling certain components to avoid injury to fingers.

Electrical connectors may be damaged in transit to the customers, and damage may result in creation of hazards. Products should therefore be examined prior to installation/use and rejected if found to be damaged.

### 4. DISPOSAL

Incineration of certain materials may release noxious or even toxic fumes.

### 5. APPLICATION

Connectors with exposed contacts should not be selected for use on the current supply side of an electrical circuit, because an electric shock could result from touching exposed contacts on an unmated connector. Voltages in excess of 30 V ac or 42.5 V dc are potentially hazardous and care should be taken to ensure that such voltages can not be transmitted in any way to exposed metal parts of the connector body. The connector and wiring should be checked, before making live, to have no damage to metal parts or insulators, no solder blobs, loose strands, conducting lubricants, swarf, or any other undesired conducting particles. Insulation resistance should be checked to make certain that no low resistance joints or spurious conducting path are existing between contacts and exposed metal parts of the connector body. Further the contact resistance of the connectors should be measured within the electrical circuit in order to identify high resistances which result in excessive connector heating.

Always use the correct application tools as specified in the Data Sheet/Catalogue.

Do not permit untrained personnel to wire, assemble or trumper with connectors.

For operation voltage please see appropriate national regulations.

### IMPORTANT GENERAL INFORMATION.

#### 1. Air and creepage paths/Operating voltage

The admissible operating voltages depend on the individual applications and the valid national and other applicable safety regulations.

For this reason the air and creepage path data are only reference values. Observe reduction of air and creepage paths due to PC board and/or harnessing.

#### 2. Temperature

All information given are temperature limits. The operation temperature depends on the individual application.

#### 3. Other important information

Cannon continuously endeavours to improve their products. Therefore, Cannon products may deviate from the description, technical data and shape as shown in this catalogue and data sheets.

#### 4. Harnessing and Assembly Instructions

If applicable, our special harnessing and/or assembly instruction has to be adhered to. This is provided at request.

ITT Cannon manufactures the highest quality products available in the marketplace; however these products are intended to be used in accordance with the specifications in this catalog. Any use or application that deviates from stated operating specifications is not recommended and may be unsafe. No information and data contained in this catalog shall be construed to create any liability on the part of Cannon. Any new issue of this catalog shall automatically invalidate and supersede any and all previous issues. **A limited warranty applies to Cannon products. Except for obligations assumed by Cannon under this warranty, Cannon shall not be liable for any loss, damage, cost of repairs, incidental or consequential damages of any kind, whether or not based on express or implied warranty, contract, negligence or strict liability arising in connection with the design, manufacture, sale, use or repair of the products.** Product availability, prices and delivery dates are exclusively subject to our respective order confirmation form; the same applies to orders based on development samples delivered. This catalog is not be construed as an offer. It is intended merely as an invitation to make an offer. By this publication, Cannon does not assume responsibility or any liability for any patent infringements or other rights of third parties which may result from its use. Reprinting this catalog is generally permitted, indicating the source. However, Cannon's prior consent must be obtained in all cases.

Cannon is a trademark of ITT Industries, Inc

## X-ON Electronics

Largest Supplier of Electrical and Electronic Components

*Click to view similar products for [Heavy Duty Power Connectors](#) category:*

*Click to view products by [ITT](#) manufacturer:*

Other Similar products are found below :

[1424439](#) [1424438](#) [09330062652](#) [2-8675P1](#) [580129-2](#) [605601-1](#) [6340G1](#) [6341G1](#) [6360G1](#) [6373G1](#) [6374g2](#) [6396G1](#) [647757-1](#) [66394-4](#)  
[6643411-1](#) [6646058-2](#) [6646137-1](#) [6646138-1](#) [6646348-1](#) [6646479-1](#) [6646608-1](#) [6646786-1](#) [6646940-1](#) [6651091-1](#) [6651525-1](#) [6651529-1](#)  
[6651778-1](#) [6651788-1](#) [696465-1](#) [696475-1](#) [73000005059](#) [73000005349](#) [73000005642](#) [73080255059](#) [73080965046](#) [765-15-0080A](#)  
[765-16-0080B](#) [789.700-44](#) [789.700-54](#) [80-1010](#) [80-9](#) [827381-1](#) [829992-1](#) [902-77-02113](#) [PL00U-301-10D10](#) [PM103MOOLOO](#)  
[PM16S1620S32-50](#) [PM212MOOLOO](#) [PM309FOOLOO](#) [PM324FOOLCH](#)