

### ■Features

- Single chip
- Super high brightness of surface mount LED
- Sorting for  $I_v$  and  $V_f$  @ 20mA of  $I_f$
- Compact package outline  
(LxWxT) of 1.0mm x 0.5mm x 0.4mm
- Compatible to IR reflow soldering.

### ■Applications

- Backlighting (switches, keys, etc.)
- Marker lights (e.g. steps, exit ways, etc.)

### ■Outline Dimension

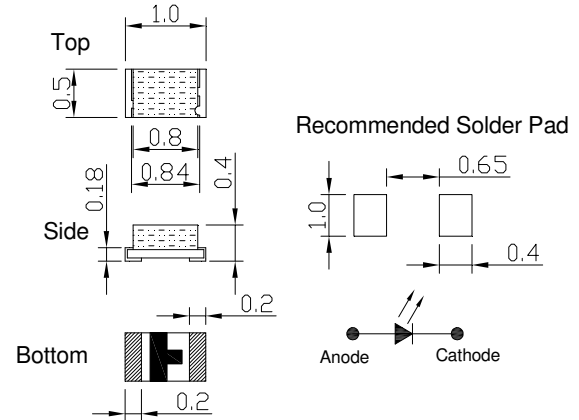

### ■Absolute Maximum Rating

( $T_a=25^\circ\text{C}$ )

| Item                       | Symbo     | Value                      |        | Unit             |
|----------------------------|-----------|----------------------------|--------|------------------|
|                            |           | R /YG/ O/Y                 | B/PG/W |                  |
| DC Forward Current         | $I_F$     | 20                         | 20     | mA               |
| Pulse Forward Current*     | $I_{FP}$  | 100                        | 100    | mA               |
| Reverse Voltage            | $V_R$     | 5                          | 5      | V                |
| Power Dissipation          | $P_D$     | 52                         | 72     | mW               |
| Operating Temperature      | $T_{opr}$ | -40 ~ +85                  |        | $^\circ\text{C}$ |
| Storage Temperature        | $T_{stg}$ | -40~ +85                   |        | $^\circ\text{C}$ |
| Lead Soldering Temperature | $T_{sol}$ | 260 $^\circ\text{C}$ /5sec |        | -                |

\*Pulse width Max 0.1ms, Duty ratio max 1/10

### ■Electrical -Optical Characteristics

( $T_a=25^\circ\text{C}$ )

| Part Number | Color        |    | $V_F$ (V)         |      |      | $I_R$ ( $\mu\text{A}$ ) | $I_v$ (mcd)       |      |      | $\lambda_D$ (nm) |      |      | 2 $\theta$ 1/2(deg) |
|-------------|--------------|----|-------------------|------|------|-------------------------|-------------------|------|------|------------------|------|------|---------------------|
|             |              |    | Min.              | Typ. | Max. | Max.                    | Min.              | Typ. | Max. | Min.             | Typ. | Max. | Typ.                |
|             |              |    | $I_F=20\text{mA}$ |      |      | $V_R=5\text{V}$         | $I_F=20\text{mA}$ |      |      |                  |      |      |                     |
| OSM50402C1C | Warm White   | M5 | 2.8               | 3.2  | 3.6  | 100                     | 250               | 400  | 600  | 3000-3500K       |      |      | 120                 |
| OSWA0402C1C | Pure White   | WA | 2.8               | 3.2  | 3.6  | 100                     | 250               | 400  | 600  | 6500-9000K       |      |      | 120                 |
| OSB50402C1C | Blue         | B5 | 2.8               | 3.2  | 3.6  | 100                     | 60                | 90   | 150  | 465              | 470  | 475  | 120                 |
| OSG50402C1C | Pure Green   | G5 | 2.8               | 3.1  | 3.6  | 100                     | 250               | 400  | 600  | 520              | 525  | 530  | 120                 |
| OSG80402C1C | Yellow green | G8 | 1.8               | 2.0  | 2.6  | 100                     | 20                | 30   | 40   | 565              | 570  | 575  | 120                 |
| OSY50402C1C | Yellow       | Y5 | 1.8               | 2.0  | 2.6  | 100                     | 50                | 100  | 200  | 585              | 590  | 595  | 120                 |
| OSO50402C1C | Orange       | O5 | 1.9               | 2.2  | 2.6  | 100                     | 50                | 100  | 200  | 600              | 605  | 610  | 120                 |
| OSR50402C1C | Red          | R5 | 1.8               | 2.0  | 2.6  | 100                     | 50                | 100  | 200  | 620              | 625  | 630  | 120                 |

Note: \*  $V_f$  tolerance:  $\pm 0.05\text{V}$  \* Dominant wavelength tolerance:  $\pm 1\text{nm}$

\* Luminous intensity is NIST reading. Luminous intensity tolerance:  $\pm 10\%$

■ Optical and electrical characteristics

TYPICAL ELECTRICAL/OPTICAL CHARACTERISTIC CURVES

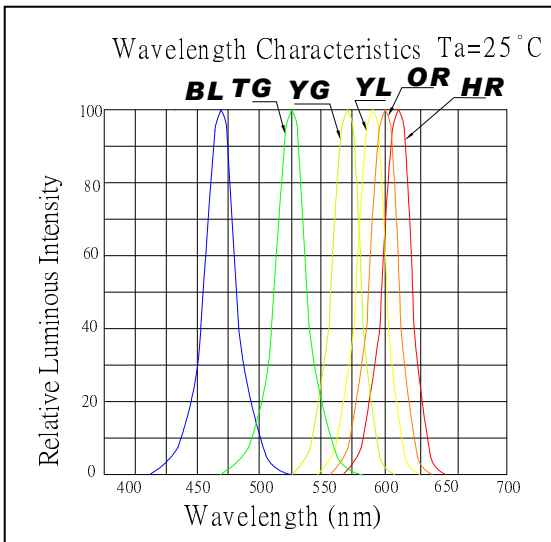
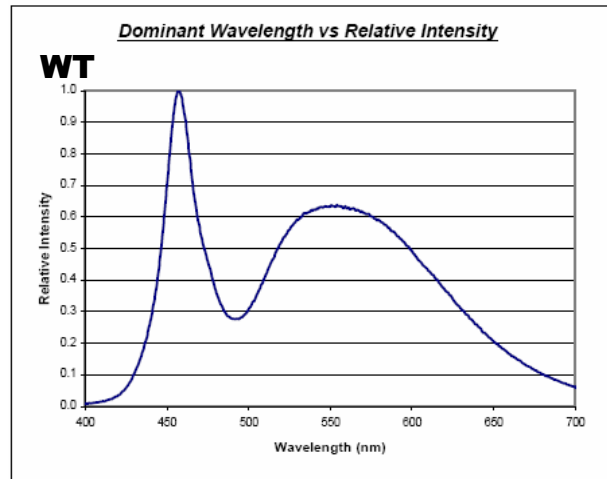
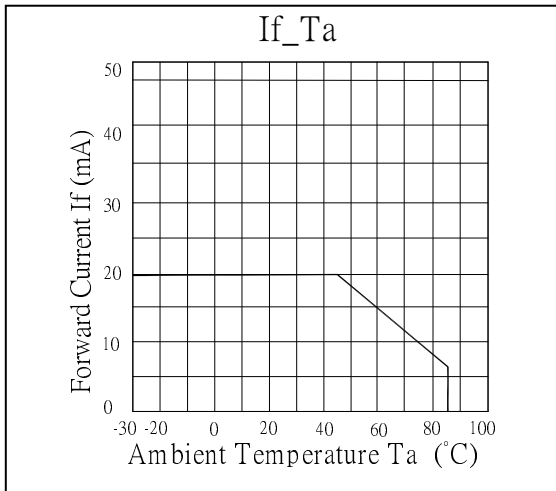
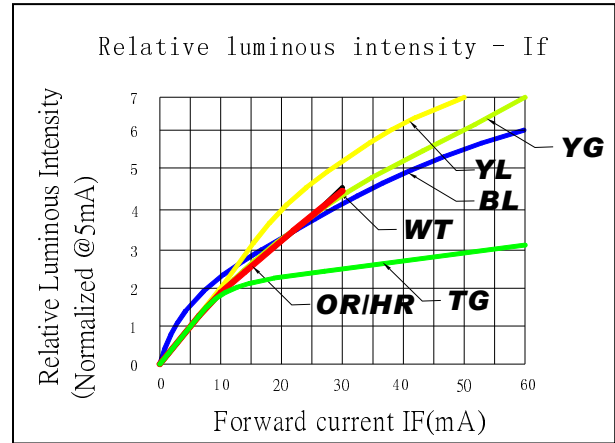
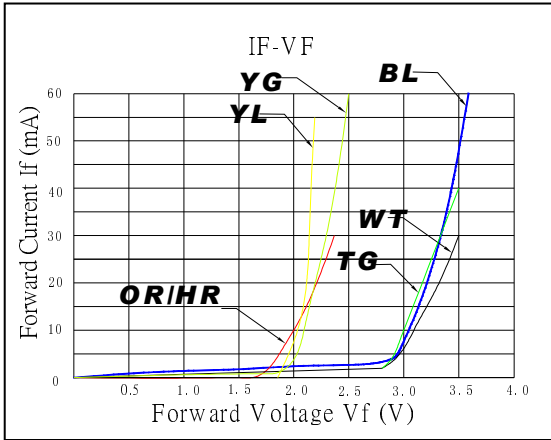

## ■ Recommended Soldering Temperature – Time Profile (Reflow Soldering)

### Surface Mounting Condition

In automatic mounting of the SMD LEDs on printed circuit boards, any bending, expanding and pulling forces or shock against the SMD LEDs should be kept min. to prevent them from electrical failures and mechanical damages of the devices.

### Soldering Reflow

- Soldering of the SMD LEDs should conform to the soldering condition in the individual specifications.
- SMD LEDs are designed for Reflow Soldering.
- In the reflow soldering, too high temperature and too large temperature gradient such as rapid heating/cooling may cause electrical & optical failures and damages of the devices.
- We cannot guarantee the LEDs after they have been assembled using the solder dipping method.

### 1) Lead Solder

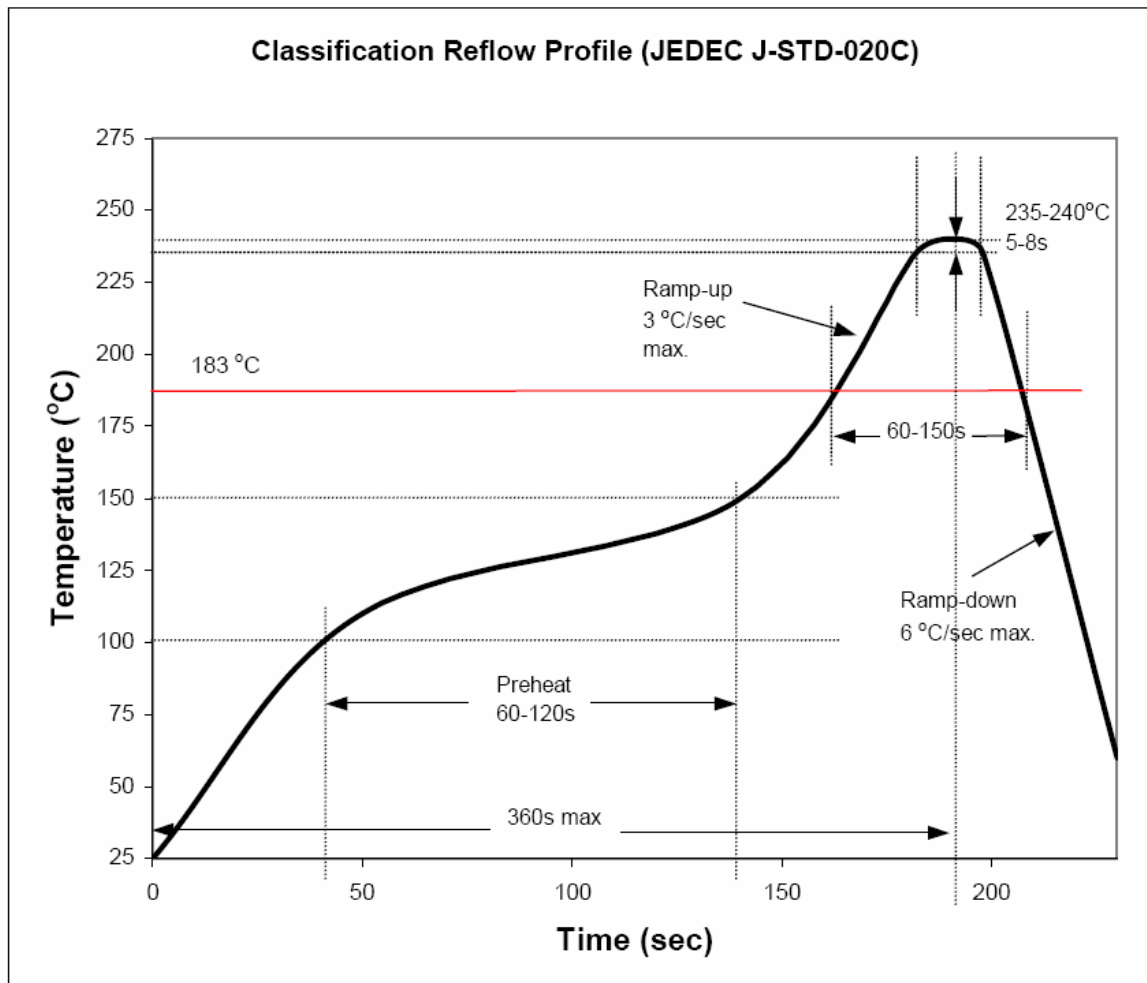

## 2) Lead-Free Solder

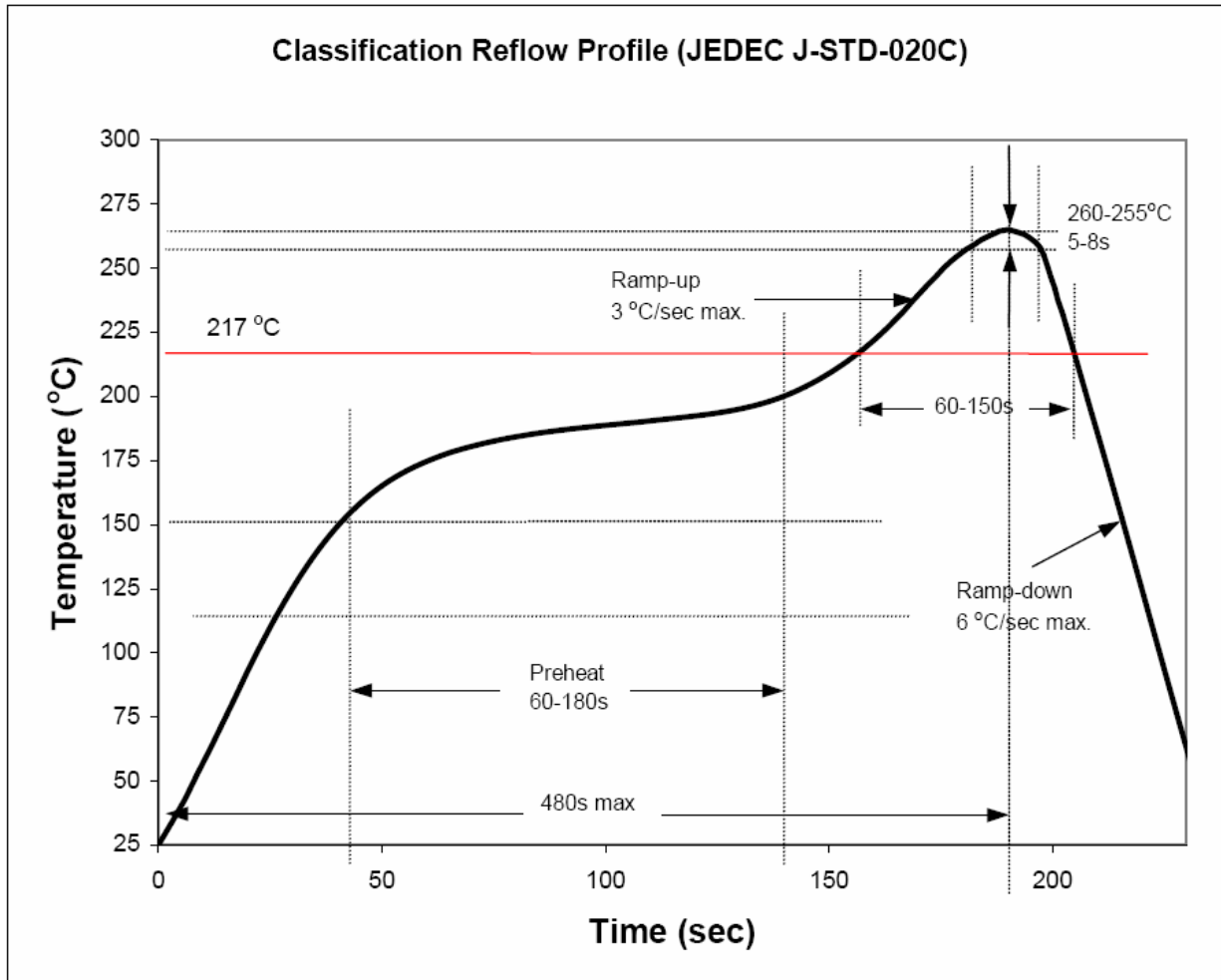

## 3) Manual Soldering conditions.

- Lead Solder

Max. 300 for Max. 3sec, and only one time. °C

- Lead-free Solder

Max. 350 for Max. 3sec, and only one time. °C

- There is possibility that the brightness of LEDs is decreased, which is influenced by heat or ambient atmosphere during reflow. It is recommended to use the nitrogen reflow method.

- After LEDs have been soldered, repair should not be done. As repair is unavoidable, a double-head soldering iron should be used. It should be confirmed beforehand whether the characteristics of the LEDs will be damaged by repairing or not.

- Reflow soldering should not be done more than two times.

■ **Material**

White/ Blue/ Yellow green/ Yellow/ Orange/ Red /True green :

|                                  | Material                                       |
|----------------------------------|--|
| 1. Lead-frame. / Soldering Leads | Cu Alloy With Ni, Au Plating.                  |
| 2. PCB                           | BT Resin.                                      |
| 3. Encapsulate                   | Epoxy Resin.                                   |
| 4. Die                           | AllnGaP based                                  |
| 5. Bonding wire                  | Au<br>Chip : Ball Bonding / PCB : Ball Bonding |

Note: Product is lead-free (Pb free).

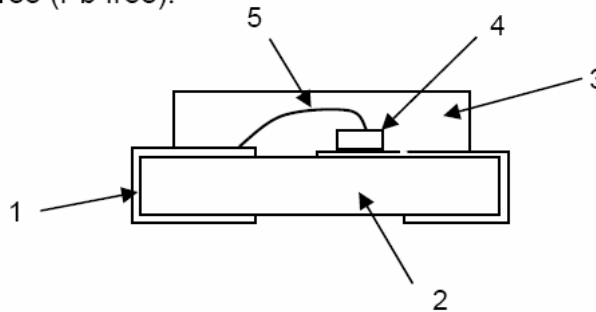

■ Taping and Orientation.

1. Quantity: 4,000 units/reel    2. Diameter: 178 mm    3. General Tolerance :  $\pm 0.1$

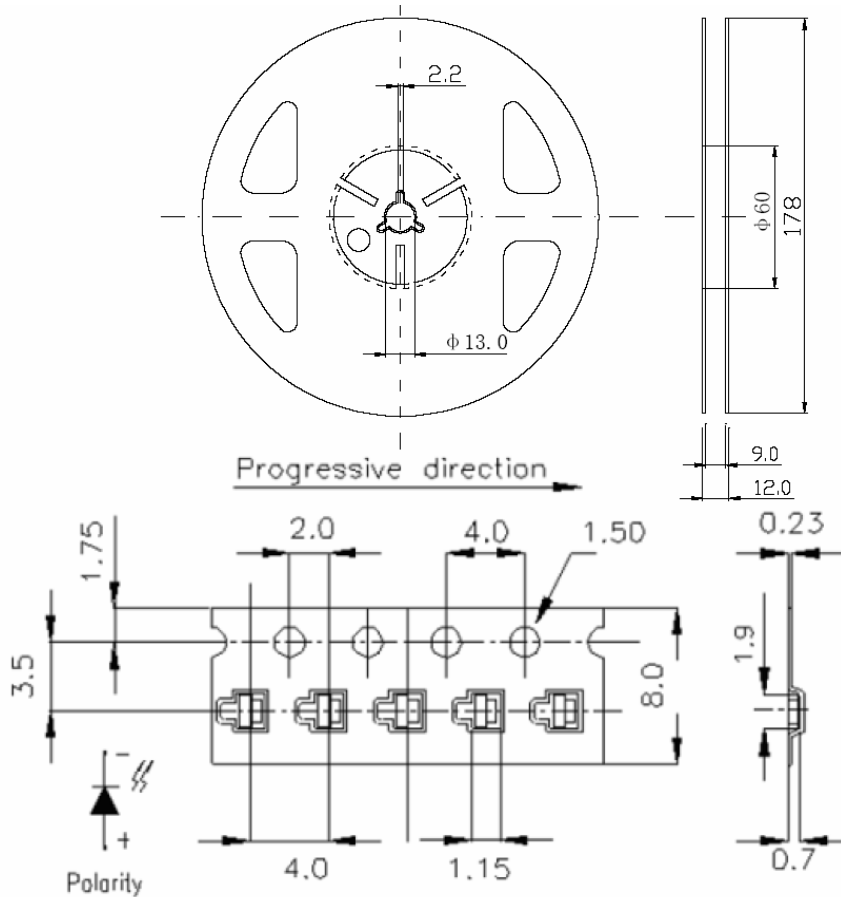

■ Cautions:

1. After open the package, the LED should be kept at 30 °C, 30%RH or less. The LED should be soldered within 24 hours (1 day) after opening the package.
2. Heat generation must be taken into design consideration when using the LED.
3. Power must be applied resistors for protection, over current would be caused the optic damage to the devices and wavelength shift.
4. Manual tip solder may cause the damage to Chip devices, so advised that heat of iron should be lower than 15W with temperature control under 5 seconds at 230-260 deg. C. ( The device would be got damage in re working process, recommended under 5 seconds at 230-260 deg. C)
5. All equipment and machinery must be properly grounded. It is recommended to use a wristband or anti-electrostatic glove when handing the LED.
6. Use IPA as a solvent for cleaning the LED. The other solvent may dissolve the LED package and the epoxy, Ultrasonic cleaning should not be done.
7. Damaged LED will show unusual characteristics such as leak current remarkably increase, turn-on voltage becomes lower and the LED get unlight at low current.

■ Reliability Test :

|   | Test Item                                     | Test Conditions                                       | Time    | Test Q'ty | Fail Q'ty | O.K  |
|---|---|---|---------|-----------|-----------|------|
| 1 | Thermal Cycle Test<br>(168 cycles)            | H:+75°C 30 min<br>~<br>L:-35°C 30 min                 | 168 Hrs | 20        | 0         | Pass |
| 2 | Thermal Shock Test<br>(84 cycles, Rate= 5min) | H:+85°C (Holding 1 hr)<br>~<br>L:-40°C (Holding 1 hr) | 168 Hrs | 20        | 0         | Pass |
| 3 | High Temp. Storage Test                       | Temp.:100°C   | 168 Hrs | 20        | 0         | Pass |
| 4 | Low Temp. Storage Test                        | Temp.: -40°C  | 168 Hrs | 20        | 0         | Pass |
| 5 | High Temp. High Humidity Test                 | 85°C/85%RH,   | 168 Hrs | 20        | 0         | Pass |
| 6 | Press Cook Test                               | T=121°C, P=2atms<br>H=100%RH                          | 168 Hrs | 20        | 0         | Pass |
| 7 | Operating Life Test                           | IF=20 mA, 25°C  | 168 Hrs | 20        | 0         | Pass |
| 8 | IR-Reflow Test                                | Max 260°C<br>(Pb free condition)                      | 2 Times | 10        | 0         | Pass |

**Conclusions:**

The reliability tests were designed to evaluate both package integrity as well as workability of product performance over time.

All samples have done well by completed test requirement and passed all the qualification criteria with zero failure. From design standpoint, the package is robust enough to meet its datasheet conditions.

Based on the good result shows on the above test, this product is qualified and released for market.

# X-ON Electronics

Largest Supplier of Electrical and Electronic Components

*Click to view similar products for [High Power LEDs - White](#) category:*

*Click to view products by [Optosupply](#) manufacturer:*

Other Similar products are found below :

[G42180-08](#) [B42180-08](#) [STW8Q2PA-R5-HA](#) [SZ5-M1-W0-00-V3/W2-AA](#) [LTPL-P00DWS57](#) [LZP-D0WW00-0000](#) [CLM-9-30-90-36-AC32-F4-3](#)  
[SZ5-M1-WW-C8-V1/V3-FA](#) [XHP50B-00-0000-0D0HJ240H](#) [BXRC-27E2000-D-73](#) [BXRC-27G2000-D-73](#) [BXRC-30E1000-D-73](#) [BXRC-30G2000-D-73](#) [BXRC-40E1000-D-73](#) [BXRE-30G2000-B-73](#) [BXRE-30G2000-C-73](#) [BXRE-50C2001-C-74](#) [CXM-22-27-80-54-AC30-F4-3](#) [XHP50B-00-0000-0D0UH245G](#) [XHP50B-00-0000-0D0UG227H](#) [XHP50B-00-0000-0D0HJ245G](#) [MP-5050-8100-27-80](#) [MP-5050-6100-65-80](#) [MP-5050-6100-50-80](#) [MP-5050-6100-40-80](#) [MP-5050-6100-30-80](#) [MP-3020-3100-65-80](#) [MP-3020-3100-40-90](#) [MP-3014-1100-40-80](#) [MP-3014-1100-35-80](#) [MP-3014-1100-30-80](#) [MP-3014-1100-27-80](#) [CXM-22-30-80-54-AC30-F4-3](#) [MP-3014-1100-57-70](#) [LTW-2835SZK57](#) [BXEM-50C0000-0-000](#) [WW-WNA30TS-U1\(M1\)](#) [KW CSLPM2.CC-8L8M-4L8N](#) [KW CSLPM2.CC-8L8M-4O9Q](#) [KW DPLS32.SB-6H6J-E5P7-EG-Z264](#) [L1V1-507003V500000](#)  
[CXM-22-35-80-36-AC10-F3-3](#) [KW3 CGLNM1.TG-Z6QF6-EBVFFCBB46-DFGA](#) [GWCS8PM1.PM-LSLU-A232-1](#) [JB5630AWT-H-H65EA0000-NZ000001](#) [XHP50B-00-0000-0D0UG430H](#) [CXM-22-35-90-54-AC40-F5-3](#) [CXM-22-35-80-54-AC40-F5-3](#) [OSM51206E1N-0.8T](#) [OSM53535C1A-150MA](#)