





High Frequency Wire Wound Transformers

ER Platforms - ER9.5, ER11 and ER14.5



-  Transformers and Inductors
-  Power: 1W to 9W
-  Three Different SMT Platforms
-  Custom designs available

Electrical Specifications @ 25°C - Operating Temperature -40°C to +125°C

Part ^{3,4} Number	Application ²	Turns Ratio			Primary Secondary Isolation	Primary Inductance (μH MIN)	Leakage Inductance (μH MAX)	DCR (mΩ MAX)			
		Pri.	Sec.	Pri. Aux.				Pri.	Pri. Aux.	Sec. A	Sec. B
ER9.5 - 8 PIN SMT - (12.1mm x 10.7mm x 6.6mm MAX)											
PB2090NL	2.4W Flyback Transformer Vin=36-72v, Freq.=200kHz Vout=12v/0.2A, 12v/.05mA	1	0.33	0.330	1500Vdc Operational	132 @ 0.41A	5	700	820	185	N/A
PB2109NL	1.25W Flyback Transformer Vin=18-36v, Freq.=200kHz Vout=5v/0.25A, 12v/50mA	1	0.714	0.287	1500Vdc Operational	62 @ 0.52A	3	350	650	50	N/A
PB2110NL	2.4W Flyback Transformer Vin=18-36v, Freq.=200kHz Vout=12v/0.2A, 12v/50mA	1	0.68	0.680	1500Vdc Operational	32 @ 0.8A	2	180	820	185	N/A
PB2135NL	.5W Flyback Transformer Vin=20-30v, Freq.=200kHz Vout=±5v/50mA	1	0.42 0.42	N/A	1000Vdc Operational	814 @ 0.8A	11	5772	N/A	364	364
PA0663NL	2.6W Flyback Transformer Vin=4.5-5.5v, Freq.=200kHz Vout=±5v/0.5A, 6v/0.02mA	1	1.11 (5v) 1.33 (6v)	N/A	2500Vdc Operational	4.6	0.15	100	N/A	97	73
ER11 - 10 PIN SMT - (12.7mm x 11.4mm x 6.6mm MAX)											
PA1032NL	5W Flyback Transformer Vin=30-57v, Freq.=250kHz Vout=3.3v/1.5A, 10v/15mA	1	0.166	0.500	1500Vdc Operational	46.6	1.65	380	250	15	N/A
PB2162NL	6W Flyback Transformer Vin=18-36v, Freq.=200kHz Vout=±12v/0.25A, 12v/20mA	1	0.393	0.393	500Vdc Operational	85 @ 0.8A	2.5	490	1100	298	298
ER14.5 - 10 PIN SMT - (16.5mm x 15.5mm x 7.6mm MAX)											
PA1006NL	5W Flyback Transformer Vin=30-57v, Freq.=250kHz Vout=3.3v/1.5A, 10v/15mA	1	0.154	0.462	1500Vdc Operational	152	5	670	750	21	N/A
PA1026NL	5W Flyback Transformer Vin=30-57v, Freq.=250kHz Vout=3.3v/1.5A, 10v/15mA	1	0.115	0.500	1500Vdc Operational	152	5	670	830	10	N/A
PA1085NL	5W Flyback Transformer Vin=30-57v, Freq.=250kHz Vout=3.3v/1.5A, 10v/15mA	1	0.115	0.269	1500Vdc Operational	152	5	670	450	10	N/A

High Frequency Wire Wound Transformers

ER Platforms - ER9.5, ER11 and ER14.5

Notes:

1. The temperature of the component (ambient plus temperature rise) must be within the stated operating temperature range.
2. The above transformers and inductors have been tested and approved by Pulse's power IC partners and are sited in the appropriate datasheet or evaluation board documentation at these companies. To determine which IC and IC partners are matched with the above Pulse part numbers please consult the IC Cross Reference on the Pulse website.

3. Add "T" suffix to the part number for Tape & Reel version (i.e. PA1032NLT).

Mechanicals

ER9.5

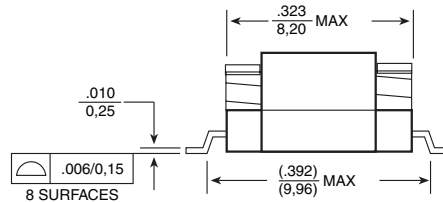
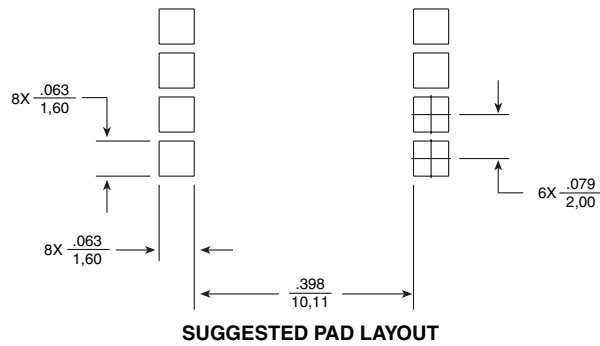
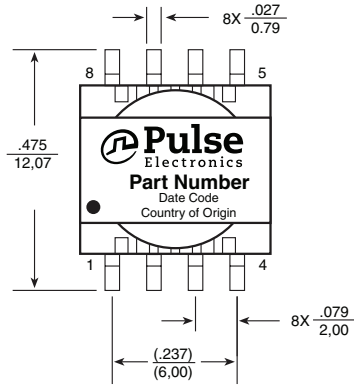

ER11

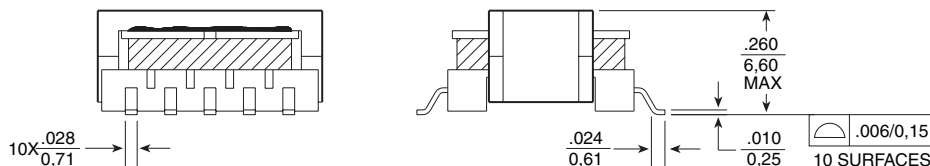
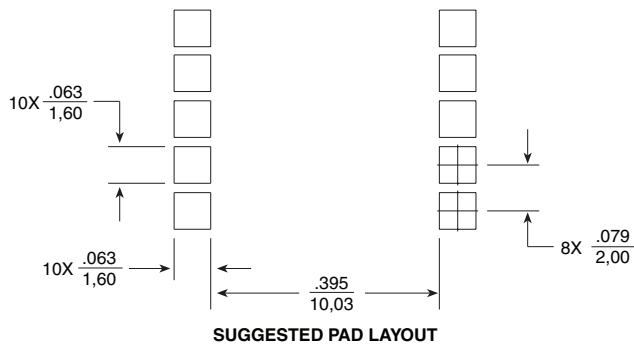
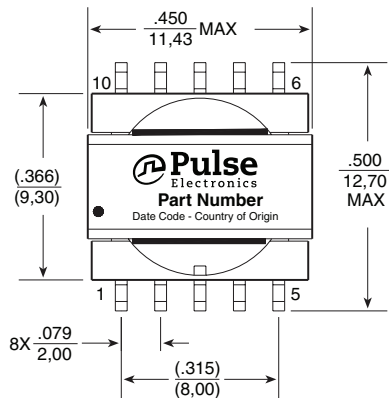

High Frequency Wire Wound Transformers

ER Platforms - ER9.5, ER11 and ER14.5

Mechanical (continued)

ER14.5

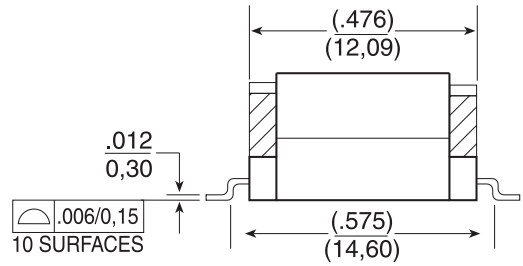
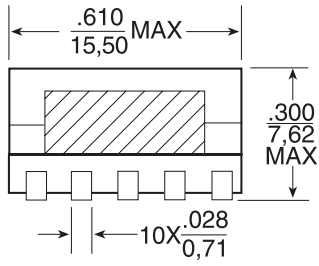
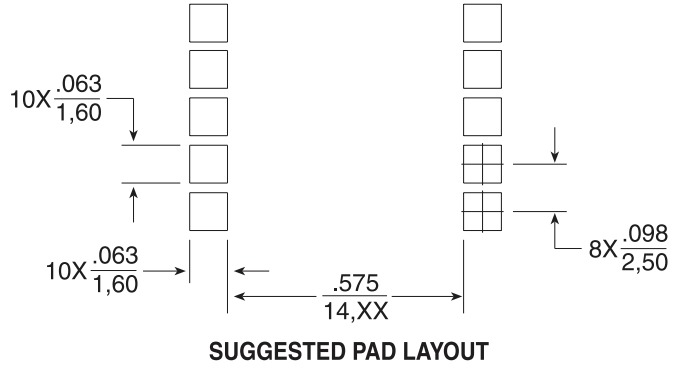
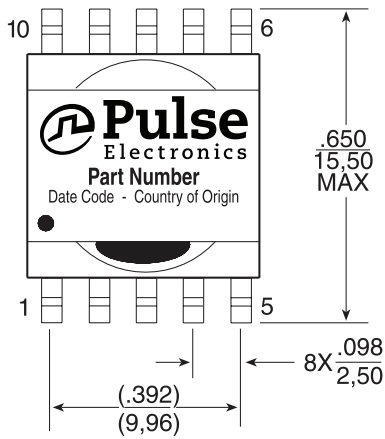

Schematics

ER9.5

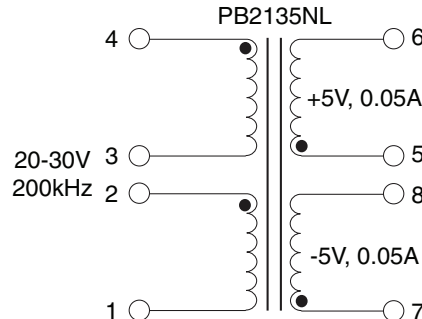
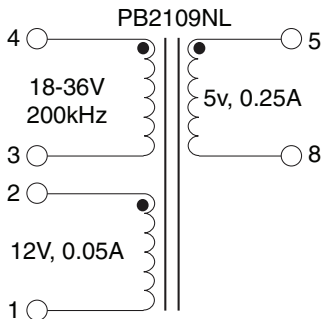
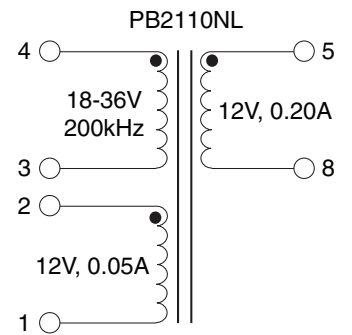
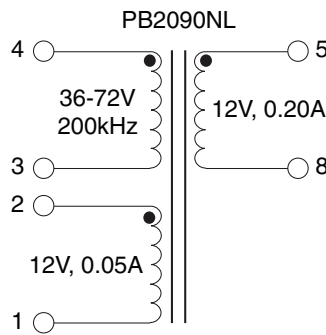
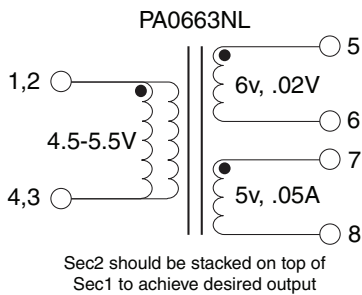

Connect pins 2 and 3 on PCB to complete Primary

High Frequency Wire Wound Transformers

ER Platforms - ER9.5, ER11 and ER14.5

Schematics (continued)

ER11

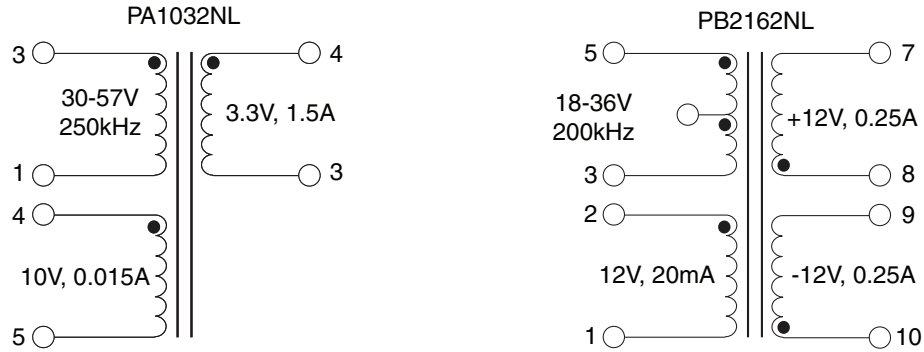

ER14.5

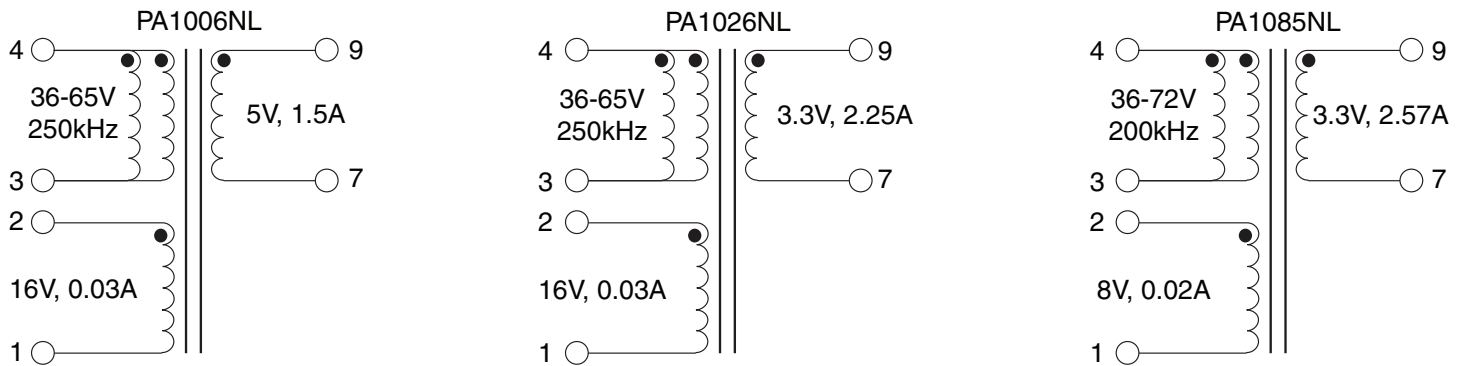

X-ON Electronics

Largest Supplier of Electrical and Electronic Components

Click to view similar products for [Fixed Inductors](#) category:

Click to view products by [Pulse manufacturer](#):

Other Similar products are found below :

[MLZ1608M6R8WTD25](#) [MLZ1608N6R8LT000](#) [MLZ1608N3R3LTD25](#) [MLZ1608N3R3LT000](#) [MLZ1608N150LT000](#)

[MLZ1608M150WTD25](#) [MLZ1608M3R3WTD25](#) [MLZ1608M3R3WT000](#) [MLZ1608M150WT000](#) [MLZ1608A1R5WT000](#)

[MLZ1608N1R5LT000](#) [B82432C1333K000](#) [PCMB053T-1R0MS](#) [PCMB053T-1R5MS](#) [PCMB104T-1R5MS](#) [CR32NP-100KC](#) [CR32NP-](#)

[151KC](#) [CR32NP-180KC](#) [CR32NP-181KC](#) [CR32NP-1R5MC](#) [CR32NP-390KC](#) [CR32NP-3R9MC](#) [CR32NP-680KC](#) [CR32NP-820KC](#)

[CR32NP-8R2MC](#) [CR43NP-390KC](#) [CR43NP-560KC](#) [CR43NP-680KC](#) [CR54NP-181KC](#) [CR54NP-470LC](#) [CR54NP-820KC](#) [CR54NP-8R5MC](#)

[MGDQ4-00004-P](#) [MGDU1-00016-P](#) [MHL1ECTTP18NJ](#) [MHL1JCTTD12NJ](#) [PE-51506NL](#) [PE-53601NL](#) [PE-53630NL](#) [PE-53824SNLT](#) [PE-](#)

[62892NL](#) [PE-92100NL](#) [PG0434.801NLT](#) [PG0936.113NLT](#) [PM06-2N7](#) [PM06-39NJ](#) [HC2LP-R47-R](#) [HC2-R47-R](#) [HC3-2R2-R](#) [HC8-1R2-R](#)