

RNPP-302

MULTIFUNCTIONAL THREE PHASE VOLTAGE MONITORING RELAY

OPERATING MANUAL



Quality control system on the production complies with requirements ISO 9001:2008

Review the Operating manual before using the unit.

Store the unit in the operating environment for 2 hours before switching to the mains.

Do not use abrasives or organic compounds for cleaning (spirit, gasoline, solvents, etc.).

NEVER ATTEMPT TO REMOVE AND REPAIR THE UNIT.

Some of the unit components may be live.

NEVER ATTEMPT TO OPEN AND REPAIR THE PROTECTED EQUIPMENT, IF SWITCHED TO THE UNIT SOCKET.

Do not allow any water on the contacts of the connecting blocks or inner elements of the unit.

Do not use the unit in corrosive environments with the air containing acids, alkalis, oils, etc.

- 2 -
APPLICATION

Universal Three phase voltage monitoring relay RNPP-302 (hereinafter **RNPP-302**) is designed for the permanent voltage monitoring, control and protection of the equipment with rated voltage parameters of 220/380V and 230/400V or 240/415V at rated frequency of 50Hz. RNPP-302 protects the power load from the following alarm situations and power faults:

- over/under voltage, voltage surges and fluctuations,
- phase loss,
- phase coincidence,
- wrong phase sequence,
- phase imbalance in the AC power circuits
- control over the full phase switching of the contactor
- remote control input signal to operate with the power load as per requirement

The RNPP-302 operates with the magnetic coil of the external contactor which in its turn operates with the power load. The RNPP-302 constantly checks (before and after turning on) the condition of the power contacts of magnetic contactor and detects the stuck together and burned contacts. When the power parameters return back to normal after the interruption or when the reason of the tripping is eliminated the RNPP-302 performs automatic reclosing and thus restart the equipment. It does so following a time delay (0-600 sec), set previously by the user.

RNPP-302 relay may work in four independent modes:

1. phase loss monitoring mode without voltage level control (parameter $tPr = 0$);
2. minimum voltage monitoring mode (parameter $tPr = 1$);
3. maximum voltage monitoring mode (parameter $tPr = 2$);
4. symmetrical min/max voltage monitoring mode (parameter $tPr = 3$)

The LED display of the RNPP-302 indicates:

- Acting value (true RMS) of the phase voltage or alternatively line voltage depending on mode of operation;
- Voltage fault in mains power supply and the type of the interruption;
- State of output relay contacts (OPEN/CLOSE)

NOTICE. The term “rated voltage” used in this device manual means that the input voltage corresponds all settings and parameters adjusted by user (see Table 2).

Time countdown of the autoreclosing delay starts from the moment of the fault detection (not from the moment when the power parameters recovered to their corresponding rated values)

During the countdown of the autoreclosing time delay LED indicator REL will blink in case of the normal power parameters.

1. MAIN FEATURES

Digital input to turn ON/OFF the RNPP-302 remotely ;

Changeover relay output (8A 250V at $\cos \varphi=1$) for the operation by the magnetic contactor to commutate any desired power load;

Normally Opened relay contact (8A 250V at $\cos \varphi=1$) for the signalization

Measurement accuracy for tripping thresholds: not exceed 3V

Rated phase/line voltage 220/380V (230/400V or 240/415V)

The adjustable ranges for minimal voltage; maximal voltage tripping; phase imbalance; time delays for the protection tripping; automatic restart (autoreclosing) time and other adjustable parameters are shown in the Table 2.

Rated power consumption: not exceed 5 W

Protection degree of the enclosure case: IP40

Protection degree of terminal block: IP20

Operational temperature range, °C: from - 35 to +55

Storage temperature conditions, °C: from - 45 to +75

Weight not more than 0,3 kg

Mounting: fit the standard 35 mm DIN-rail

Mounting position: arbitrary - as per requirement

Dimensions and control buttons are shown on Figure 1.

RNPP-302 complies with requirements:

IEC 60947-1:2004, IDT; IEC 60947-6-2:1992, IDT; CISPR 11:2004, IDT; IEC 61000-4-2:2001, IDT.

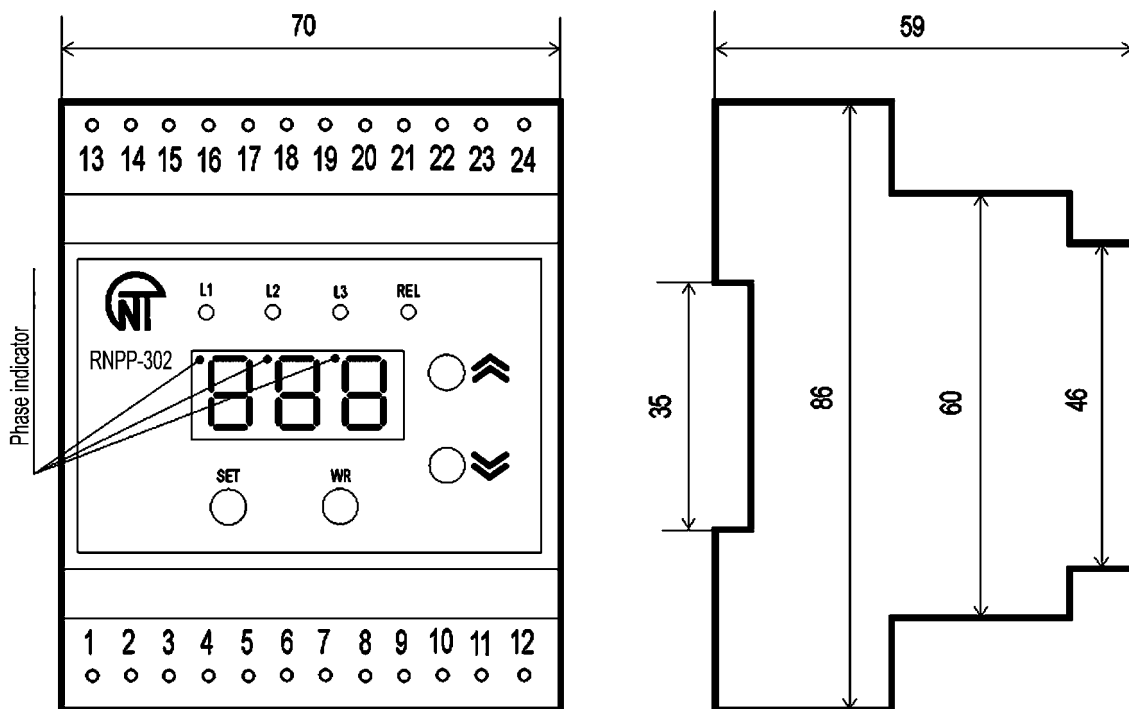

- Red LED “L1” – lights up in case of the alarm on phase L1
- Red LED “L2” – lights up in case of the alarm on phase L2
- Red LED “L3” – lights up in case of the alarm on phase L3
- Green LED “REL” – lights up when the output relay is closed
- “SET” button – to set the parameter value
- “WR” – to write and save the parameter
- “ \blacktriangle and \blacktriangledown ” Buttons - to scroll and adjust the parameters value in menus

Notes: \blacktriangle button hereinafter in text – “UP”, \blacktriangledown button – “DOWN”

2. START UP PROCEDURE

Connect the contactor (magnetic starter) to the RNPP-302 and make all other necessary connections as shown on **Figure 2**

Connect mains power supply to the input terminals of RNPP-302

Turn ON the power and adjust all required settings according to **Table 2**

NOTE. All wiring connections must be performed on the dead device.

3. RNPP-302 SETTINGS AND CONTROLS

3.1. At the initial state on the front panel the following information is shown:

- depending the operation mode phase-to-neutral voltage on each phase (L1, L2, L3) if the parameter $UD=0$ or alternatively phase-to-phase voltage (L1-L2; L2-L3; L3-L1) if parameter $UD=1$;
- Phase Indicator (indicator of the currently measured phase (L1, L2 or L3));
- Operational state of the output relay (Open/Closed)

To select the phase manually ($UD=0$) use **DOWN** and **UP** buttons, alternatively if parameter $UD=1$ the measurement values on phases are displayed in turns automatically every 5 seconds

3.2. To view and change the parameters it is necessary press **SET** button and all phase indicators will light up. To scroll between the parameters use **DOWN** and **UP** buttons. To enter the parameter and change value press **SET** button. Then using **DOWN** and **UP** buttons set the desired values. To save the parameter and exit the current menu press **WR** button. To exit the menu without saving press **SET** button. If none of the buttons are pressed within 15 seconds the RNPP-302 returns to initial state.

3.3. To restore default factory settings quickly it is necessary to press simultaneously **SET**, **DOWN** and **UP** buttons and energize the RNPP-302 while keeping these buttons pressed. Then the display should indicate “nAU”. Then Turn OFF the device. Factory settings are restored.

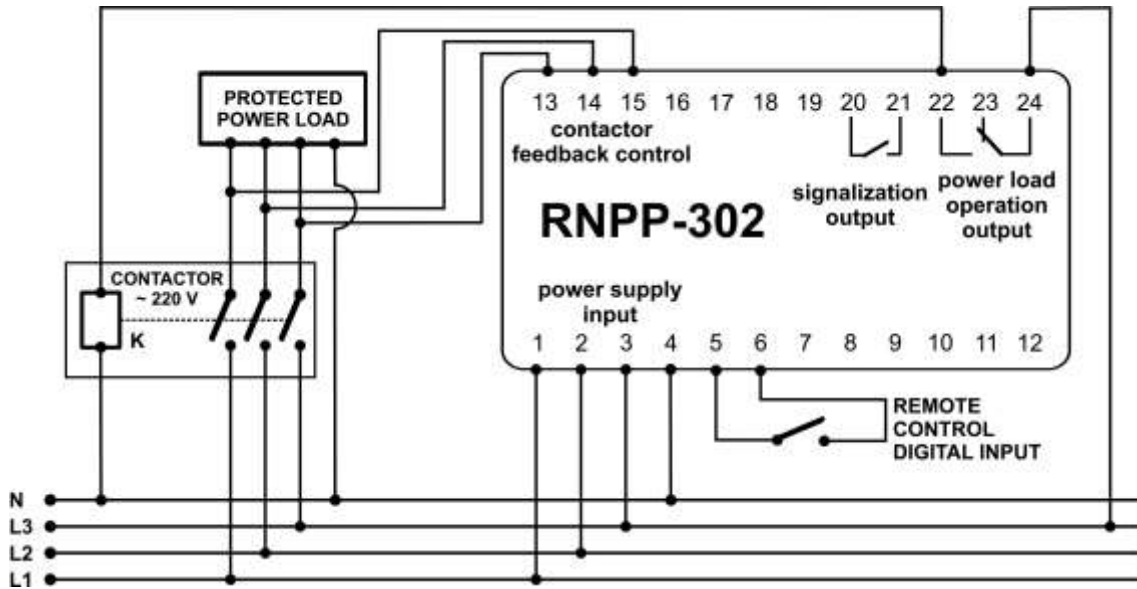

Figure 2. Wiring diagram of the RNPP-302 to the 4 wires power circuits (with neutral phase present).

NOTES. In case the RNPP-302 is installed in 3 wires power circuit (without neutral) the connection of the Neutral Phase (Terminal #4) is optional (neutral may not be connected).
On the wiring diagram 220V contactor is shown like the example, if the connection of 380V contactor is necessary contactor coil "K" should be connected to L1 or L2 phases.

4. RNPP-302 OPERATION

4.1. Modes of RNPP-302 operation.

Depending on the tPr parameter value the RNPP-302 can work in following modes:

- 1) Phase loss relay (the relay monitors only the presence of voltage (not the voltage level) on every phase) $\rightarrow tPr = 0$;
- 2) Minimal voltage monitoring relay $\rightarrow tPr = 1$;
- 3) Maximal voltage monitoring relay $\rightarrow tPr = 2$;
- 4) Over/Under voltage monitoring (min/max) mode $\rightarrow tPr = 3$;

Modes of operation, adjustable parameters, time delays and other controls are shown in **Table 2**.

4.2. Voltage monitoring modes

4.2.1 First start up instructions

In case of first start up during the installation or if the RNPP-302 was deenergized on first turning ON it is necessary to add 0,3 - 0,4 seconds to the automatic reclosing time delay (tPP parameter). This time is necessary for preparation to work and for self-testing of the RNPP-302.

4.2.2. Minimal voltage monitoring mode ($tPr = 1$)

If the **RNPP-302** was initially in turned OFF state then in case the correct voltage is applied to the device it will automatically turn ON within the delay time defined by tPP parameter: the "REL" LED will light up and terminals 23, 24 will open while 22, 24 and 20, 21 will close.

If the input voltage get lower than the minimal tripping threshold (parameter U_{min}) within the curtain time defined by user (parameter t_{min}) – then the RNPP-302 will turn OFF the power load: terminals 23, 24 will close while 22, 24 and 20, 21 will open.

RNPP-302 has the operative acceleration in turn OFF time. If the voltage decrease is more than 80 V regardless of the preset voltage tripping threshold the RNPP-302 will cut OFF the power load within 0,1 second.

After the recovery of the voltage parameters – when controlled voltage becomes 5-6 V higher than minimal tripping threshold (voltage hysteresis is 5-6 V) the relay will automatically turn ON the power load with delay time defined by tPP parameter.

4.2.3. Maximal voltage monitoring mode ($tPr = 2$)

In this mode power load should necessarily be connected to terminals 23,24.

When giving correct power supply to the input of the RNPP-302 the position of the output contacts don't change and correspond to "cold state": terminals 23, 24 are closed while 22, 24 and 20, 21 are open.

If the increase in input voltage is more than the maximal tripping threshold (parameter U_{max}) within the

curtain time defined by user (parameter t_{off}) – then the RNPP-302 will turn OFF the power load: terminals 23, 24 will open while 22, 24 and 20, 21 will close.

After the recovery of the voltage parameters – when controlled voltage becomes 5-6 V lower than maximal tripping threshold (voltage hysteresis is 5-6 V) the relay will automatically turn ON the power load with delay time defined by t_{PP} parameter.

4.2.4. Over/Under voltage monitoring (min/max) mode ($t_{Pr} = 3$)

If the RNPP-302 was initially in turned OFF state then in case the correct voltage is applied to the device it will automatically turn ON within the delay time defined by t_{PP} parameter: the “REL” LED will light up and terminals 23, 24 will open while 22, 24 and 20, 21 will close.

If the input voltage get lower than the minimal tripping threshold (parameter U_{min}) within the curtain time defined by user (parameter t_{off}) – then the RNPP-302 will turn OFF the power load: terminals 23, 24 will close while 22, 24 and 20, 21 will open.

If the voltage decrease is more than 80 V regardless of the preset voltage tripping threshold the RNPP-302 will cut OFF the power load within 0,1 second (accelerated turn OFF).

After the recovery of the voltage parameters – when controlled voltage becomes 5-6 V higher than minimal tripping threshold (voltage hysteresis is 5-6 V) the relay will automatically turn ON the power load with delay time defined by t_{PP} parameter.

If the increase in input voltage is more than the maximal tripping threshold (parameter U_{max}) within the curtain time defined by user (parameter t_{off}) – then the RNPP-302 will turn OFF the power load: terminals 23, 24 will close while 22, 24 and 20, 21 will open. After the recovery of the voltage parameters – when controlled voltage becomes 5-6 V lower than maximal tripping threshold (voltage hysteresis is 5-6 V) the relay will automatically turn ON the power load with delay time defined by t_{PP} parameter.

4.3. Control of the additional voltage parameters

In all above stated modes of operation the RNPP-302 performs permanent control over additional voltage parameters and in case of deviation from the preset values it turns OFF the power load and turns ON the alarm signalization. On the recovery of voltage level and cancel of the alarm situation RNPP-302 will turn ON the power load after the t_{PP} time and turn OFF the signalization.

RNPP-302 performs the control over following parameters:

1) Phase imbalance. If the parameter $C_{PI}=1$ the RNPP-302 performs the control over phase imbalance and the tripping threshold for the phase imbalance is defined by parameter U_{PI} .

2) Wrong phase sequence and phase combination. If the parameter $C_{PS}=1$ RNPP-302 monitors the correct phase sequence and the absence of the phase combination.

3) Feedback control of the voltage presence on the contactor (magnetic starter) terminals. If the contactor has burned or stuck contacts – RNPP-302 will cut the output relay and turn ON the alarm signalization. This function is of a great importance as the equipment could be damaged due to bad or damaged contactor whereas all input voltage parameters are fine and correct.

If the parameter $C_{VL}=1$ the RNPP-302 detects the presence of the voltage on the output terminals of the contactor and in case the stuck contacts it turns OFF the power load and turns ON the alarm signalization.

If the parameter $C_{VL}=2$ the RNPP-302 checks the voltage presence on the output contactor contacts and allows all contacts to be opened (full-phase disconnection is permitted). The alarm situation is detected only in case one or two contacts of the contactor are opened. So it may be the situation when only one or two phases will come to the equipment because of a damaged or not properly working contactor and this may result to the damage of the equipment or installation. This function is essential when the equipment or power load need to be switched ON/OFF using the remote control switch or additional technological contact.

To restart the operation of the RNPP-302 again after the detection of wrong phase sequence or the absence of voltage on the contactor output terminals it will be necessary to eliminate the reason of the power interruption, then reconnect the RNPP-302 and then turn ON the power supply.

4) Control of the external signals coming to the digital input. It is defined by parameters $C_{DI} I=1$ ($C_{DI} I=2$). RNPP-302 has the digital input that may be used to detect the external alarm situation (for example the signal from thermostat built into the AC motor coil). On getting the signal the RNPP-302 immediately disconnect the power load and displays the “A1” alarm code. When the alarm situation is eliminated (there is no signal from the external source) the RNPP-302 will automatically turn on the power load with the delay time defined by t_{PP} parameter.

4.4. Indication

In the absence of the alarm situations on the LED display of RNPP-302 it shown the value of acting voltage (RMS voltage) on the selected phase marked by phase indicator (please see **Figure 1**).

“REL” LED indicator shows the ON/OFF state of the output relays of RNPP-302. If “REL” LED lights that mean that the relay is turned ON. During the countdown of the autoreclosing time delay LED indicator REL will blink in case of the normal power parameters. Time countdown of the autoreclosing delay starts from the moment of the fault detection (not from the moment when the power parameters recovered to their corresponding rated values).

In case the power interruptions in minimal voltage, maximal voltage, phase loss and phase imbalance the corresponding LED will light up to mark the phase where the interruption happened.

If the wrong phase sequence was detected by RNPP-302 all red LEDs will light up in turns.

On all other alarm situations all red LEDs will light permanently.

All codes of the alarm situation are shown on the LED display according to the **Table 1**.

4.5. Signalization

Signalization relay output turns ON/OFF simultaneously with the main output relay that operates with the power load. This allows to use signalization relay for the operation by the contactor also. So the main output relay could be used as a signalization relay with normally closed contacts (contacts are closed when there is no alarm situation).

Table 1 - ALARM CODES

Signalization codes shown on display	
A1	Digital input Turn OFF remote control
U--	Minimal voltage
U--	Maximal voltage
UPP	Phase imbalance
U..	The absence of voltage on the contactor output terminals or in case of not full phase switching of the contactor
U' ,	Wrong phase sequence
U 0	Phase loss

Table 2 - RNPP-302 OPEATION MODES

Adjustable and measures parameters	Parameter codes	Minimal value	Maximal Value	Factory setting	Description
Basic parameters and SETTINGS					
Voltage measurement indication	U	0	1	1	0 - Manual phase selection. It is displayed the voltage on the phase which is marked by Phase Indicator. 1 - Automatic Phase Selection. Voltage measurements on each phase are shown in turns every 5 sec
Digital input signal to turn OFF the RNPP-302 relay remotely	CC 1	0	2	0	0 - not enabled 1 - on closing of the digital input contact the RNPP-302 immediately turns OFF the power load 2 - on opening of the digital input contact the RNPP-302 immediately turns OFF the power load
Mode of RNPP-302 operation	tPr	0	3	3	0 - PHASE LOSS RELAY (minimal and maximal voltage are not controlled), RNPP-302 turns OFF the power load only if voltage disappear on 1 or 2 phases; 1 - MINIMAL VOLTAGE RELAY, RNPP-302 turns OFF the power load if the voltage gets lower than preset U-- value;

Adjustable and measures parameters	Parameter codes	Minimal value	Maximal Value	Factory setting	Description
					2 - MAXIMAL VOLTAGE RELAY, RNPP-302 turns OFF the power load if the voltage gets higher than preset U_{max} value; 3 - MINIMAL/MAXIMAL VOLTAGE RELAY, RNPP-302 turns OFF the power load if the voltage gets lower than U_{min} value or higher than U_{max} value
Method to set Voltage deviation	SUR	0	1	0	0 - voltage values are set up in absolute values 1 - voltage values are set up in % of rated power parameters
Phase imbalance control	UPP	0	1	1	0 - not enabled 1 - enabled
Phase sequence control	$U'1$	0	1	1	0 - not enabled 1 - enabled
Control of the voltage presence on the output contacts of the contactor	UUL	0	2	0	0 - not enabled 1 - enabled 2 - enabled, and full-phase TURN OFF or TURN ON of the contactor is allowed (for example for the cases where manual stop/start function is required)
Voltage setting					
Voltage measurement	$U01$	0	3	0	0 - phase voltage (phase-to-neutral) 220V 1 - phase voltage (phase-to-neutral) 230V 2 - phase voltage (phase-to-neutral) 240V 3 - line voltage (phase-to-phase) 380V 4 - line voltage (phase-to-phase) 400V 5 - line voltage (phase-to-phase) 415V
Minimal voltage setting, V: In % values	U_{min}	85 147	230 398	180 311	If $SUR = 0$ and $U01 = 0, U01 = 1, U01 = 2$; If $SUR = 0$ and $U01 = 3, U01 = 4, U01 = 5$;
Maximal voltage setting, V: In % values	U_{max}	235 407	295 510	245 424	If $SUR = 0$ and $U01 = 0, U01 = 1, U01 = 2$; If $SUR = 0$ and $U01 = 3, U01 = 4, U01 = 5$;
Phase imbalance, V: In % values	UPP	10 17	80 138	15 25	If $SUR = 0$ and $U01 = 0, U01 = 1, U01 = 2$; If $SUR = 0$ and $U01 = 3, U01 = 4, U01 = 5$;
		5	35	5	If $SUR = 1$ and any values of $U01$ parameter.
Time setting					
Autoreclosing time delay, sec	t_{PP}	0,5	600	10	
Time delay to TURN OFF the power load in case of minimal voltage interruption detected, sec	t_{min}	0,1	30	10	
Time delay to TURN OFF the power load in case of maximal voltage interruption detected, sec	t_{max}	0,1	30	1	
Time delay to TURN OFF the power load in case the phase imbalance is detected, s	t_{PP}	0,1	30	3,0	

Adjustable and measures parameters	Parameter codes	Minimal value	Maximal Value	Factory setting	Description
Time delay to TURN OFF the power load in case the phase loss is detected, s	EL0	0,1	30	0,5	
Time delay to TURN OFF the power load in case the alarm signal comes from the digital input, s	ELC	0,1	600	10	
Device version	REL			12	

5. STORAGE AND SHIPPING CONDITIONS

The **RNPP-302** in manufacturers package should be stored in enclosed rooms with ambient temperature from -45° to +75° C and exposed to not more than 80% of relative humidity. It should be no fumes in the air that may exert a deleterious effect on package and the RNPP-302 components. The Buyer must provide the protection of the relay against possible mechanical damages in transit.

6. WARRANTY AND CLAIMS CONDITIONS

Warranty period is 36 month upon the day of sale.

The manufacturer shall repair the unit, in the compliance with the operating manual by the user, within the warranty period.

RNPP-302 is not subject to the warranty service in the following cases:

- expiry of the warranty period; availability of mechanical damages;
- attempts to open and repair ; traces of moisture attack or in the presence of foreign items inside the unit;
- damage caused by an electric current or voltage values which exceed the nameplate, improper or careless handling of the product is not subject to the instructions for installation and use;
- damage is caused by electric current or voltage in excess to the permissible values as indicated in the Operating manual.

Warranty service is provided in the place of purchase. Post-warranty service shall be provided by the manufacturer.

The manufacturer's warranty does not cover compensation for direct or indirect losses associated with the unit transportation to the place of purchase or manufacturer's plant.

Earnest request: indicate the reason for return in the notice of faults field at the return of the device or in case of submitting for warranty service or post-warranty service.

X-ON Electronics

Largest Supplier of Electrical and Electronic Components

Click to view similar products for [General Purpose Relays category](#):

Click to view products by [Novatek manufacturer](#):

Other Similar products are found below :

[APF30318](#) [JVN1AF-4.5V-F](#) [PCN-105D3MHZ](#) [5JO-10000S-SIL](#) [5JO-1000CD-SIL](#) [5JO-400CD-SIL](#) [LY2S-AC220/240](#) [LYQ20DC12](#)
[6031007G](#) [6131406HQ](#) [6-1393099-3](#) [6-1393099-8](#) [6-1393122-4](#) [6-1393123-2](#) [6-1393767-1](#) [6-1393843-7](#) [6-1415012-1](#) [6-1419102-2](#) [6-](#)
[1423698-4](#) [6-1608051-6](#) [6-1608067-0](#) [6-1616170-6](#) [6-1616248-2](#) [6-1616282-3](#) [6-1616348-2](#) [6-1616350-1](#) [6-1616350-8](#) [6-1616358-7](#) [6-](#)
[1616359-9](#) [6-1616360-9](#) [6-1616931-6](#) [6-1617039-1](#) [6-1617052-1](#) [6-1617090-2](#) [6-1617090-5](#) [6-1617347-5](#) [6-1617353-3](#) [6-1617801-8](#) [6-](#)
[1617802-2](#) [6-1618107-9](#) [6-1618248-4](#) [M83536/1-027M](#) [CX-4014](#) [MAHC-5494](#) [MAVCD-5419-6](#) [703XCX-120A](#) [7-1393100-5](#) [7-1393111-7](#)
[7-1393144-5](#) [7-1393767-8](#)