



DC COMPONENTS CO., LTD.

RECTIFIER SPECIALISTS

KBPC / MB
35005 / 3505

THRU

KBPC / MB
3510 / 3510

TECHNICAL SPECIFICATIONS OF SINGLE-PHASE SILICON BRIDGE RECTIFIER

VOLTAGE RANGE - 50 to 1000 Volts

CURRENT - 35 Amperes

FEATURES

- * Metal case for Maximum Heat Dissipation
- * Surge overload ratings-400 Amperes
- * Low forward voltage drop

MECHANICAL DATA

- * Case: Metal, electrically isolated
- * Epoxy: UL 94V-0 rate flame retardant
- * Terminals: Plated .25"(6.35mm) Faston lugs, solderable per MIL-STD-202E, Method 208 guaranteed
- * Polarity: As marked
- * Mounting position: Any
- * Weight: 30 grams

MAXIMUM RATINGS AND ELECTRICAL CHARACTERISTICS

Ratings at 25 °C ambient temperature unless otherwise specified.
Single phase, half wave, 60 Hz, resistive or inductive load.
For capacitive load, derate current by 20%.



MB-25

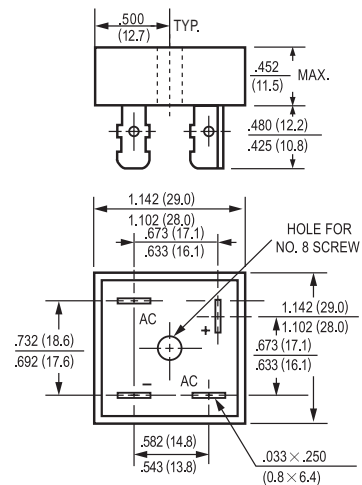

Dimensions in inches and (millimeters)

		KBPC 35005	KBPC 3501	KBPC 3502	KBPC 3504	KBPC 3506	KBPC 3508	KBPC 3510	
	SYMBOL	MB3505	MB351	MB352	MB354	MB356	MB358	MB3510	UNITS
Maximum Recurrent Peak Reverse Voltage	V _{RRM}	50	100	200	400	600	800	1000	Volts
Maximum RMS Bridge Input Voltage	V _{RMS}	35	70	140	280	420	560	700	Volts
Maximum DC Blocking Voltage	V _{DC}	50	100	200	400	600	800	1000	Volts
Maximum Average Forward Rectified Output Current at T _c = 55°C	I _o	35							Amps
Peak Forward Surge Current 8.3 ms single half sine-wave superimposed on rated load (JEDEC Method)	I _{FSM}	400							Amps
Maximum Forward Voltage Drop per element at 17.5A DC	V _F	1.1							Volts
Maximum DC Reverse Current at Rated	I _R	@ T _A = 25°C							uAmps
DC Blocking Voltage per element		@ T _A = 100°C							
I ² t Rating for Fusing (t<8.3ms)	I ² t	664							A ² Sec
Typical Junction Capacitance (Note1)	C _J	300							pF
Typical Thermal Resistance (Note 2)	R _{θJC}	2.2							°C/W
Operating and Storage Temperature Range	T _J ,T _{STG}	-55 to + 150							°C

NOTES : 1.Measured at 1 MHz and applied reverse voltage of 4.0 volts
2. Thermal Resistance from Junction to Case per leg.

RATING AND CHARACTERISTIC CURVES

(KBPC35005 THRU KBPC3510
MB3505 MB3510)

FIG. 1 - MAXIMUM NON-REPETITIVE FORWARD SURGE CURRENT

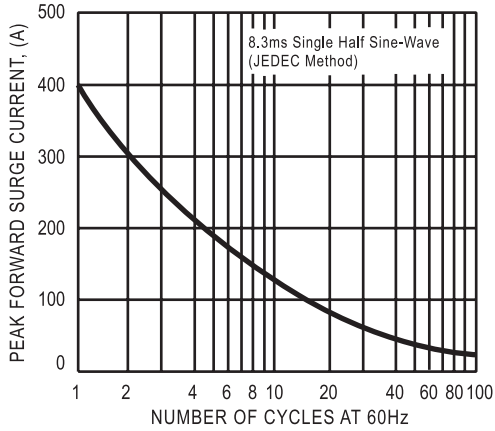

FIG. 2 - TYPICAL FORWARD CURRENT DERATING CURVE

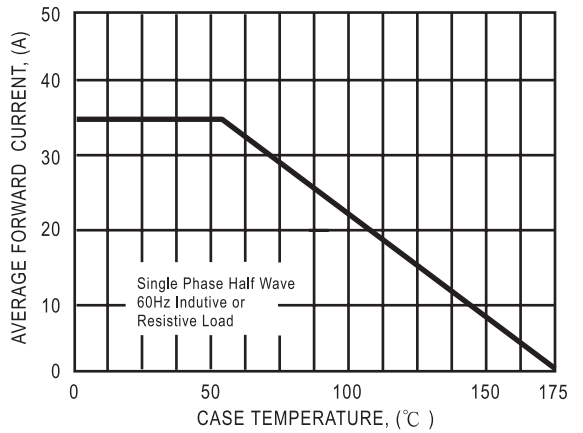

FIG. 3- TYPICAL INSTANTANEOUS FORWARD CHARACTERISTICS

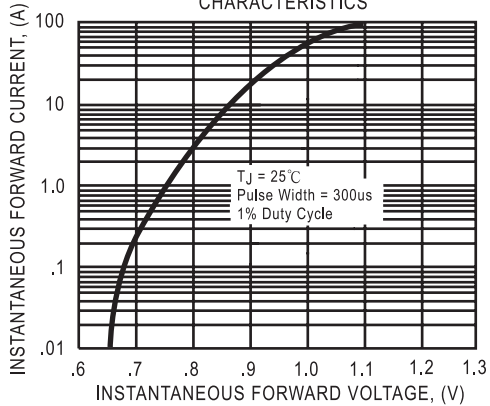
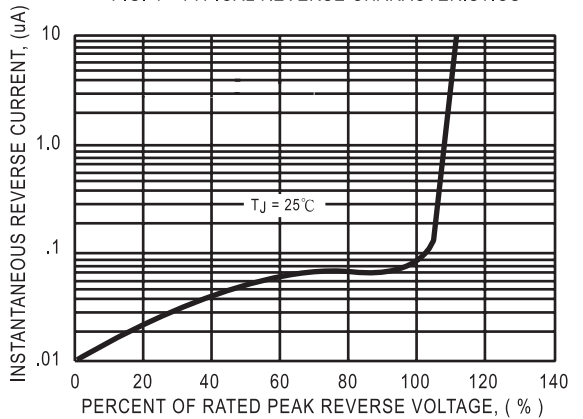

FIG. 4 - TYPICAL REVERSE CHARACTERISTICS





DC COMPONENTS CO., LTD.

RECTIFIER SPECIALISTS

KBPC / MB
35005W / 3505W
THRU
KBPC / MB
3510W / 3510W

TECHNICAL SPECIFICATIONS OF SINGLE-PHASE SILICON BRIDGE RECTIFIER

VOLTAGE RANGE - 50 to 1000 Volts

CURRENT - 35 Amperes

FEATURES

- * Metal case Maximum Heat Dissipation
- * Surge overload ratings-400 Amperes
- * Low forward voltage drop

MECHANICAL DATA

- * Case: Metal, electrically isolated
- * Epoxy: UL 94V-0 rate flame retardant
- * Lead: MIL-STD-202E, Method 208 guaranteed
- * Polarity: As marked
- * Mounting position: Any
- * Weight: 30 grams

MAXIMUM RATINGS AND ELECTRICAL CHARACTERISTICS

Ratings at 25 °C ambient temperature unless otherwise specified.
Single phase, half wave, 60 Hz, resistive or inductive load.
For capacitive load, derate current by 20%.



MB-25W

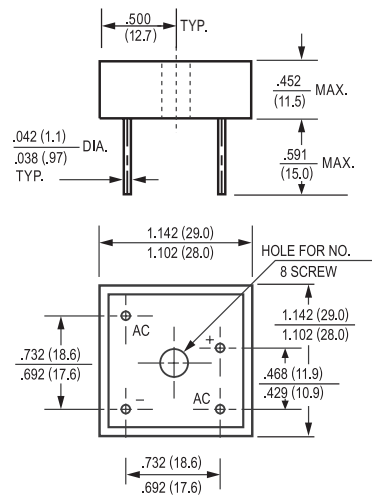

	KBPC 35005W	KBPC 3501W	KBPC 3502W	KBPC 3504W	KBPC 3506W	KBPC 3508W	KBPC 3510W
--	----------------	---------------	---------------	---------------	---------------	---------------	---------------

	SYMBOL	MB3505W	MB351W	MB352W	MB354W	MB356W	MB358W	MB3510W	UNITS
Maximum Recurrent Peak Reverse Voltage	V _{RRM}	50	100	200	400	600	800	1000	Volts
Maximum RMS Bridge Input Voltage	V _{RMS}	35	70	140	280	420	560	700	Volts
Maximum DC Blocking Voltage	V _{DC}	50	100	200	400	600	800	1000	Volts
Maximum Average Forward Rectified Output Current at T _c = 55°C	I _o	35							Amps
Peak Forward Surge Current 8.3 ms single half sine-wave superimposed on rated load (JEDEC Method)	I _{FSM}	400							Amps
Maximum Forward Voltage Drop per element at 17.5A DC	V _F	1.1							Volts
Maximum DC Reverse Current at Rated	I _R	@ T _A = 25°C						10	uAmps
DC Blocking Voltage per element		@ T _A = 100°C							
I ² t Rating for Fusing (t<8.3ms)	I ² t	664							A ² Sec
Typical Junction Capacitance (Note1)	C _J	300							pF
Typical Thermal Resistance (Note 2)	R _{θJC}	2.2							°C/W
Operating and Storage Temperature Range	T _J ,T _{STG}	-55 to + 150							°C

NOTES : 1.Measured at 1 MHz and applied reverse voltage of 4.0 volts
2. Thermal Resistance from Junction to Case per leg.

RATING AND CHARACTERISTIC CURVES

(KBPC35005W MB3505W THRU KBPC3510W MB3510W)

FIG. 1 - MAXIMUM NON-REPETITIVE FORWARD SURGE CURRENT

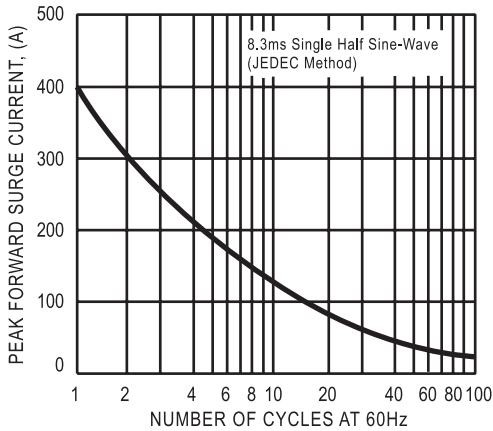

FIG. 2 - TYPICAL FORWARD CURRENT DERATING CURVE

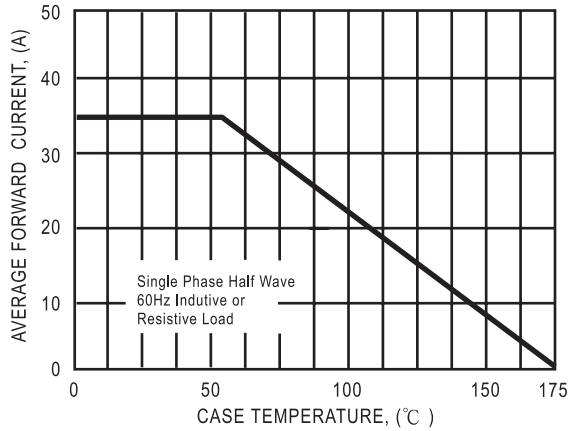

FIG. 3 - TYPICAL INSTANTANEOUS FORWARD CHARACTERISTICS

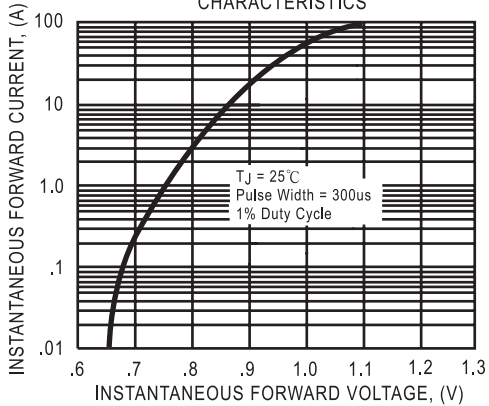
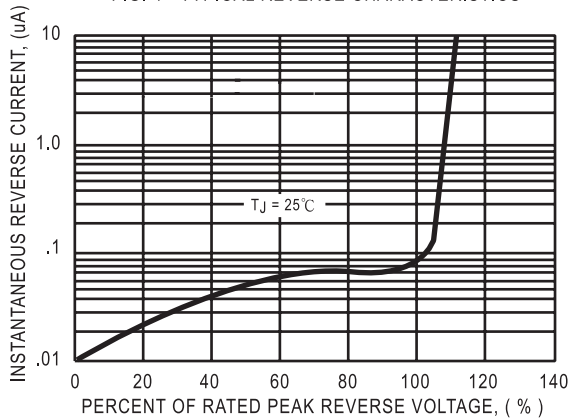

FIG. 4 - TYPICAL REVERSE CHARACTERISTICS



X-ON Electronics

Largest Supplier of Electrical and Electronic Components

Click to view similar products for [Bridge Rectifiers](#) category:

Click to view products by [DC Components](#) manufacturer:

Other Similar products are found below :

[G3SBA60-E351](#) [GBJ1504-BP](#) [GBU10B-BP](#) [GBU15J-BP](#) [GBU15K-BP](#) [GBU4A-BP](#) [GBU4D-BP](#) [GBU6B-E3/45](#) [GSIB680-E3/45](#) [DB101-BP](#) [DF10SA-E345](#) [RMB2S](#) [RCG](#) [APT30DF100HJ](#) [APT60DF20HJ](#) [B2S-E3/80](#) [BU1506-E351](#) [BU15085S-E345](#) [BU1508-E3/45](#) [BU1510-E3/45](#) [RS404GL-BP](#) [RS405GL-BP](#) [G3SBA20-E3/51](#) [G5SBA20-E3/51](#) [G5SBA60-E3/51](#) [GBJ1502-BP](#) [GBL02-E351](#) [GBL10-E3/45](#) [GBU10J-BP](#) [GBU4J-BP](#) [GBU4K-BP](#) [GBU8B-E3/45](#) [GBU8D-BP](#) [GBU8J-BP](#) [GSIB1520-E3/45](#) [MB1510](#) [MB352W](#) [MB6M-G](#) [B2M-E345](#) [B40C7000A](#) [B500C7000A](#) [MP5010W-BP](#) [MP501W-BP](#) [MP502-BP](#) [BR1005-BP](#) [BR101-BP](#) [BU1006-E345](#) [BU12065S-E3/45](#) [BU1508-E3/51](#) [BU2006-E3/45](#) [BU2008-E345](#)