



Spec-Kon®

- Overview M2
- Catalog Numbering System M2
- Terminals
 - Features and Benefits M3
 - Performance Requirements M4
 - Ring Terminals M5-M7
 - Multiple Stud Ring Terminals M8-M9
 - Large Ring Terminals M10-M12
 - Fork Terminals M13-M15
 - Locking Fork Terminals M16-M17
 - Flanged Fork Terminals M18-M19
 - Blade Terminals M20
 - Pin Terminals M21
- Disconnects
 - Features and Benefits M22
 - Design Features M22
 - Performance Requirements M22
 - Female Disconnects 23-24
 - Male Disconnects M25
 - Piggy Back Disconnects M26
 - Fully Insulated Female Disconnects M27-M28
 - Fully Insulated Male Disconnects M28
 - Insulated Female Flag Disconnects M29
 - Insulated Barrel Flag Female Disconnects M29
 - Bullet Receptacles M30
 - Bullet Disconnects M31
- Splices, Wire Joints and Quick Splices
 - Features and Benefits M32
 - Butt Splices M33-M34
 - Wire Joints M34
 - Quick Splices M34
- Installation Tools
 - Hand Tools M35-M37
 - Automated Tools M38-M39
 - Power Operated Tools M40-M41
- Application Information
 - Tool & Die Selection Chart M42
 - Strip Length Chart M42
 - Stud Size Chart M43
 - Common Conductor Size Chart M43

M

Thomas & Betts

Spec-Kon® Overview



Crimp Terminals, Disconnects, and Splices

Thomas & Betts is pleased to introduce Spec-Kon® crimp terminals, disconnects, and splices. Ideal for OEM applications, the Spec-Kon® line can be used anywhere a high number of terminations are required every day, such as the wiring harness, panelboard, telecommunications, and automotive industries.

The Spec-Kon® terminal offering includes:

- A broad selection of bulk-packaged loose piece terminals in non-insulated and insulated varieties, including male and female disconnects, rings, forks, pins, blades, butt splices, wire joints and bullet connectors.
- Terminals on mylar tape for automated applications, including the new KT-2500 power tool for frequent, repeated crimps.
- The ERG-2500 ergonomic hand tool, which crimps all sizes of insulated barrel-style Spec-Kon® wire termination products.

Catalog Numbering System

Example: KV18-6R-M

K	V	18	6	R	M
Product	Terminal and Insulation	Wire Size Range	Feature Size	Terminal Type	Box Quantity
Thomas & Betts Spec-Kon® Terminals	(Blank) Bare Non-Insulated (V) Vinyl Funnel Entry (N) Nylon Funnel Entry (VF) Vinyl Fully Insulated (NF) Nylon Fully Insulated	(18) 22-16 AWG (14) 16-14 AWG (10) 12-10 AWG (8) 8 AWG (6) 6 AWG (4) 4 AWG (2) 2 AWG	Bolt Hole: Ring and Fork Terminals Tab Width: (250 Series) Disconnects Pin Length: Pin Terminals Blade Length: Blade Terminals Diameter: Bullets	(R) Ring (MS) Multiple Stud Ring (F) Fork (LF) Locking Fork (FF) Flanged Fork (PT) Pin Terminal (BL) Blade Terminal (MD) Male Disconnect (FD) Female Disconnect (FFD) Female Flag Disconnect (PD) Piggy Back Disconnect (FB) Female Bullet (MB) Male Bullet (BS) Butt Splice (QS) Quick Splice (WJ) Wire Joint (Closed End) (BFD) Barrel Flag Disconnect	(C) = 100 (CC) = 200 (W) = 250 (D) = 500 (M) = 1,000 (T) = Mylar Tape* * Please contact Customer Service for pricing and availability.

M

Spec-Kon®

Thomas & Betts

Spec-Kon® Terminals



Features and Benefits of Spec-Kon® Terminals

- **Internal barrel serrations**—During crimping, the wire will cold flow into serrations, giving lower resistance connections and improving tensile strength.
- **Size marking**—Wire range is stamped on the tongue (metric and English) for easy access to the terminal size without drawings/packageing.
- **Electro tin plating**—Provides excellent corrosion resistance, superior finish for better-looking installation.
- **Ergonomic hand tool**—Ergonomically designed ERG-2500 completes a UL listed crimp while requiring substantially lower handle forces.
- **One tool for all insulated products**—Thomas & Betts offers a single tool that crimps the entire range of standard insulated terminals, disconnects, and butt splices. Many competitors require 2 to 4 tools to cover the same range.
- **Color coding**—Insulators are color coded for specific wire size (red=22-16AWG, blue=16-14AWG, yellow=12-10AWG). Red=8AWG, blue=6AWG.

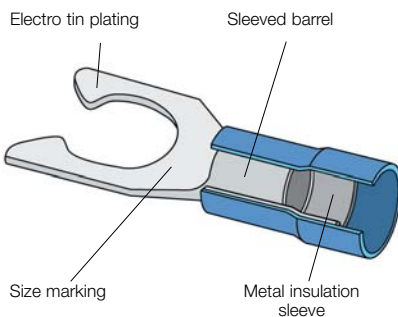

Nylon Insulated Terminals

- **Sleeved barrel**—Ensures barrel does not separate during crimping.
- **Molded insulators**—Molded insulators ensure consistent shape and quality, shaped entry speeds installation and reduces wire hang up.
- **Metal insulation sleeve**—Sleeve crimps wire insulation, providing high-vibration resistance and conductor strain relief.
- **Nylon material**—Ideal for harsh environments. Provides excellent chemical, impact and abrasion resistance.
- **Ratings**—UL Listed, cULus Listed, CSA, 600 V at 105°C.

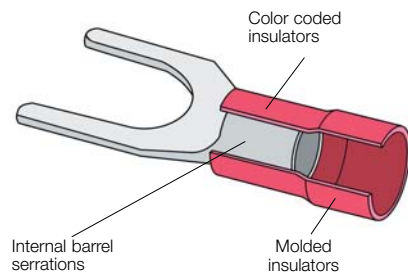

Vinyl Insulated Terminals

- **Brazed seam**—Ensures barrel does not separate during crimping.
- **Molded funnel entry insulators**—Funnel entry speeds installation and reduces wire hang up. Molded insulators ensure consistent shape and quality every time.
- **Insulation crimp**—The insulator mouth is flared to speed installation and accommodate thicker insulated wires. Also, provides insulation support strain relief in high-vibration applications.
- **Vinyl material**—Economical, moisture resistant and flame retardant (UL94V-0)
- **Ratings**—UL Listed, cULus Listed, CSA, 600 V at 105°C.

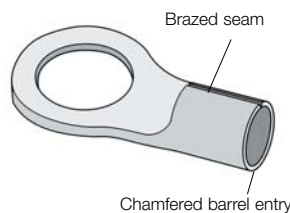

Non-Insulated Terminals

- **Brazed seam**—Ensures barrel does not separate during crimping.
- **Chamfered barrel entry**—Smoothing the barrel entry edge facilitates wire insertion.
- **Ratings**—UL Listed, cULus Listed, CSA, 2000 V.

M

Spec-Kon®

Thomas & Betts

Spec-Kon® Terminals

Design Features of Spec-Kon® Terminals

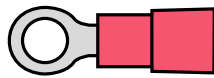

Rings

Provides the most secure and reliable connection available

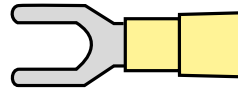

Forks

Fast and easy to install without removing the terminal block screw

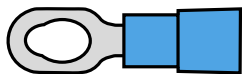

Multiple-Stud Rings

Special tongue style that accommodates 3 stud sizes with one terminal

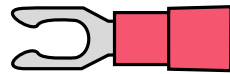

Locking Forks

Offers the secure connection of a ring terminal with the fast and easy installation of a fork terminal

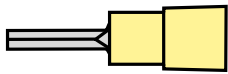

Pins

Standard insulation-style terminals for use on DIN-style/metric terminal blocks

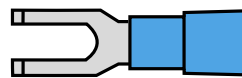

Flanged Forks

Turned-up toes provide secure connections in high-vibration applications

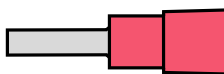

Blades

Standard insulation-style terminals for use on DIN-style/metric terminal blocks

Performance Requirements

Description	Wire Size (AWG)										
	#22	#20	#18	#16	#14	#12	#10	#8	#6	#4	#2
U.L. 486A (Terminals)											
Test Current for Max. 50°C Rise (Amps)	9	12	17	18	30	35	50	70	95	125	70
Min. Tensile Strength* (Lbs.)	8	13	20	30	50	70	80	90	100	140	180

* Pull-out force of the crimped terminal.

Applicable Spec-Kon® products meet or exceed the following test specifications:

- UL486A (Terminals)
- CSA
- UL486C (Splices)

UL listed products are shown with the applicable logos in the product section.

UL file #E9809 (Terminals).

CSA file #LR4503

Thomas & Betts

Spec-Kon[®] Terminals



- Metal Insulation Sleeve
- Molded Insulator
- Internal Barrel Serrations
- Funnel Entry

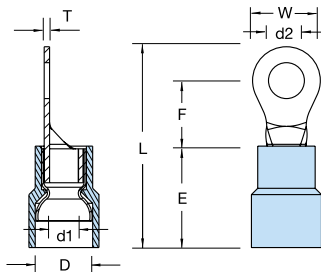

Nylon Insulated Ring Terminals



Catalog Number	Wire Range	Bolt Size (d2)	Dimension <small>inch mm</small>							
			W	F	L	E	D	d1	T	
KN18-6R-M	22-16 A.W.G. 0.5-1.5 mm ²	#6	.146 3.7	.260 6.6	.248 6.3	.803 20.4	.433 11.0	.177 4.5	.067 1.7	.030 0.75
KN18-8R-M		#8	.169 4.3	.260 6.6	.248 6.3	.803 20.4				
KN18-10R-M		#10	.209 5.3	.315 8.0	.276 7.0	.858 21.8				
KN18-14R-M		1/4	.252 6.4	.457 11.6	.433 11.0	1.094 27.8				
KN18-516R-M		5/16	.331 8.4	.457 11.6	.433 11.0	1.094 27.8				
KN14-6R-M	16-14 A.W.G. 1.5-2.5 mm ²	#6	.146 3.7	.260 6.6	.248 6.3	.83 20.4	.433 11.0	.205 5.2	.091 2.3	.031 0.8
KN14-8R-M		#8	.169 4.3	.260 6.6	.248 6.3	.803 20.4				
KN14-10R-M		#10	.209 5.3	.335 8.5	.307 7.8	.898 22.8				
KN14-14R-M		1/4	.252 6.4	.472 12.0	.433 11.0	1.094 27.8				
KN14-516R-M		5/16	.331 8.4	.472 12.0	.433 11.0	1.094 27.8				
KN14-38R-M		3/8	.413 10.5	.535 13.6	.547 13.9	1.240 31.5				
KN10-6R-D	12-10 A.W.G. 4-6 mm ²	#6	.146 3.7	.283 7.2	.240 6.1	.894 22.7	.512 13.0	.276 7.0	.134 3.4	.039 1.0
KN10-8R-D		#8	.169 4.3	.283 7.2	.240 6.1	.894 22.7				
KN10-10R-D		#10	.209 5.3	.374 9.5	.358 9.1	1.047 26.6				
KN10-14R-D		1/4	.252 6.4	.472 12.0	.413 10.5	1.164 29.5				
KN10-516R-D		5/16	.331 8.4	.591 15.0	.531 13.5	1.339 34.0				
KN10-38R-D		3/8	.413 10.5	.591 15.0	.531 13.5	1.339 34.0				
KN10-12R-D		1/2	.512 13.0	.756 19.2	.630 16.0	1.520 38.6				

M

Spec-Kon[®]

Box Quantity: (D)=500; (M)=1000

For Mylar Tape replace box quantity with (T). Example: KN18-6R-T

UL File #E9809

CSA File #LR4503

See pages in back of catalog for complete tool information.
Tool and Die Selection Chart on page M42.

Maximum Electrical Rating: 105°C 600 Volts Max.

Terminal Material: Copper

Tools used with Nylon Insulated Ring Terminals



ERG2500



KT-2500

For complete information regarding tools and the new Universal Applicator, see pages M35-M41.

Thomas & Betts

Spec-Kon® Terminals



- Molded Funnel Entry Insulator
- Brazed Seam
- Internal Barrel Serrations

Vinyl Insulated Ring Terminals



Catalog Number	Wire Range	Bolt Size (d2)	Dimension ^{inch} / _{mm}							
			W	F	L	E	D	d1	T	
KV18-6R-M	22-16 A.W.G. 0.5-1.5 mm ²	#6	.146 3.7	.260 6.6	.248 6.3	.803 20.4	.433 11.0	.157 4.0	.067 1.7	.030 0.75
KV18-8R-M		#8	.169 4.3	.260 6.6	.248 6.3	.803 20.4				
KV18-10R-M		#10	.209 5.3	.315 8.0	.276 7.0	.858 21.8				
KV18-14R-M		1/4	.252 6.4	.457 11.6	.433 11.0	1.094 27.8				
KV18-516R-M		5/16	.331 8.4	.457 11.6	.433 11.0	1.094 27.8				
KV18-38R-M		3/8	.413 10.5	.835 13.6	.547 13.9	1.240 31.5				
KV14-6R-M	16-14 A.W.G. 1.5-2.5 mm ²	#6	.146 3.7	.260 6.6	.248 6.3	.803 20.4	.433 11.0	.177 4.5	.091 2.3	.031 0.8
KV14-8R-M		#8	.169 4.3	.260 6.6	.248 6.3	.803 20.4				
KV14-10R-M		#10	.209 5.3	.335 8.5	.307 7.8	.898 22.8				
KV14-14R-M		1/4	.252 6.4	.472 12.0	.433 11.0	1.094 27.8				
KV14-516R-M		5/16	.331 8.4	.472 12.0	.433 11.0	1.094 27.8				
KV14-38R-M		3/8	.413 10.5	.535 13.6	.547 13.9	1.240 31.5				
KV10-6R-D	12-10 A.W.G. 4-6 mm ²	#6	.146 3.7	.283 7.2	.240 6.1	.894 22.7	.512 13.0	.252 6.4	.134 3.4	.039 1.0
KV10-8R-D		#8	.169 4.3	.283 7.2	.240 6.1	.894 22.7				
KV10-10R-D		#10	.209 5.3	.374 9.5	.358 9.1	1.047 26.6				
KV10-14R-D		1/4	.252 6.4	.472 12.0	.413 10.5	1.161 29.5				
KV10-516R-D		5/16	.331 8.4	.591 15.0	.531 13.5	1.339 34.0				
KV10-38R-D		3/8	.413 10.5	.591 15.0	.531 13.5	1.339 34.0				
KV10-12R-D		1/2	.512 13.0	.756 19.2	.630 16.0	1.520 38.6				

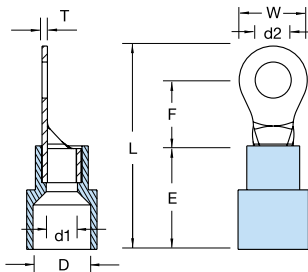

M

Spec-Kon®

Box Quantity: (D)=500; (M)=1000
 For Mylar Tape replace box quantity with (T). Example: KV18-6R-T
 UL File #E9809
 CSA File #LR4503

See pages in back of catalog for complete tool information.
 Tool and Die Selection Chart on page M42.

Maximum Electrical Rating: 105°C 600 Volts Max.
 Terminal Material: Copper

Tools used with Vinyl Insulated Ring Terminals



ERG2500



KT-2500

Thomas & Betts

Spec-Kon[®] Terminals



- Chamfered Barrel
- Brazed Seam
- Internal Barrel Serrations

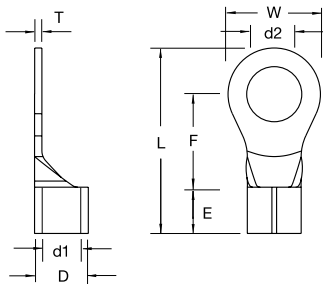

Non-Insulated Ring Terminals



Catalog Number	Wire Range	Bolt Size (d2)		Dimension <small>inch / mm</small>						
				W	F	L	E	D	d1	T
K18-6R-M	22-16 A.W.G. 0.5-1.5 mm ²	#6	.146 3.7	.260 6.6	.248 6.3	.567 14.4	.189 4.8	.134 3.4	.067 1.7	.030 0.75
K18-8R-M		#8	.169 4.3	.260 6.6	.248 6.3	.567 14.4				
K18-10R-M		#10	.209 5.3	.315 8.0	.276 7.0	.622 15.8				
K18-14R-M		1/4	.252 6.4	.457 11.6	.433 11.0	.858 21.8				
K18-516R-M		5/16	.331 8.4	.457 11.6	.433 11.0	.858 21.8				
K14-6R-M	16-14 A.W.G. 1.5-2.5 mm ²	#6	.146 3.7	.260 6.6	.248 6.3	.567 14.4	.189 4.8	.161 4.1	.091 2.3	.031 0.8
K14-8R-M		#8	.169 4.3	.260 6.6	.248 6.3	.567 14.4				
K14-10R-M		#10	.209 5.3	.335 8.5	.307 7.8	.661 16.8				
K14-14R-M		1/4	.252 6.4	.472 12.0	.433 11.0	.858 21.8				
K14-516R-M		5/16	.331 8.4	.472 12.0	.433 11.0	.858 21.8				
K14-38R-M		3/8	.413 10.5	.535 13.6	.547 13.9	1.004 25.5				
K10-6R-M	12-10 A.W.G. 4-6 mm ²	#6	.146 3.7	.283 7.2	.240 6.1	.618 15.7	.236 6.0	.220 5.6	.134 3.4	.039 1.0
K10-8R-M		#8	.169 4.3	.283 7.2	.240 6.1	.618 15.7				
K10-10R-M		#10	.209 5.3	.374 9.5	.358 9.1	.772 19.6				
K10-14R-M		1/4	.252 6.4	.472 12.0	.413 10.5	.886 22.5				
K10-516R-M		5/16	.331 8.4	.591 15.0	.531 13.5	1.063 27.0				
K10-38R-M		3/8	.413 10.5	.591 15.0	.531 13.5	1.063 27.0				
K10-12R-D		1/2	.512 13.0	.756 19.2	.630 16.0	1.244 31.6				

Box Quantity: (D)=500; (M)=1000

For Mylar Tape replace box quantity with (T). Example: K18-6R-T

UL File #E9809

CSA File #LR4503

See pages in back of catalog for complete tool information.

Tool and Die Selection Chart on page M42.

Terminal Material: Copper

Tools used with Non-Insulated Ring Terminals



ERG2002



KT-2500

Thomas & Betts

Spec-Kon[®] Terminals



Nylon Insulated Multiple Stud Ring Terminals

Catalog Number	Wire Range	Bolt Size	Dimension <small>inch mm</small>						
			W	F	L	E	D	d1	T
KN18-610MS-M	22-16 A.W.G. 0.5-1.5 mm ²	#6 - #10	.339 8.6	.311 7.9	.996 25.3	.433 11.0	.177 4.5	.067 1.7	.030 0.75
KN14-610MS-M	16-14 A.W.G. 1.5-2.5 mm ²	#6 - #10	.339 8.6	.311 7.9	.996 25.3	.433 11.0	.205 5.2	.091 2.3	.031 0.8
KN10-610MS-D	12-10 A.W.G. 4-6 mm ²	#6 - #10	.390 9.9	.350 8.9	1.154 29.3	.512 13.0	.276 7.0	.134 3.4	.039 1.0

- Single terminal for 6, 8, and 10 stud sizes
- Molded Insulator
- Metal Insulation Sleeve
- Funnel Entry

Box Quantity: (D)=500; (M)=1000

For Mylar Tape replace box quantity with (T). Example: KN18-610MS-T

UL File #E9809

CSA File #LR4503

See pages in back of catalog for complete tool information.

Tool and Die Selection Chart on page M42.

Maximum Electrical Rating: 105°C 600 Volts Max.

Terminal Material: Copper

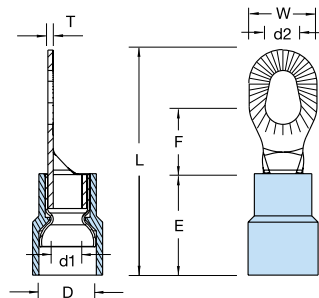

Vinyl Insulated Multiple Stud Ring Terminals

Catalog Number	Wire Range	Bolt Size	Dimension <small>inch mm</small>						
			W	F	L	E	D	d1	T
KV18-610MS-M	22-16 A.W.G. 0.5-1.5 mm ²	#6 - #10	.339 8.6	.311 7.9	.996 25.3	.433 11.0	.157 4.0	.067 1.7	.030 0.75
KV14-610MS-M	16-14 A.W.G. 1.5-2.5 mm ²	#6 - #10	.339 8.6	.311 7.9	.996 25.3	.433 11.0	.177 4.5	.091 2.3	.031 0.8
KV10-610MS-D	12-10 A.W.G. 4-6 mm ²	#6 - #10	.390 9.9	.350 8.9	1.154 29.3	.512 13.0	.252 6.4	.134 3.4	.039 1.0

Box Quantity: (D)=500; (M)=1000

For Mylar Tape replace box quantity with (T). Example: KV18-610MS-T

UL File #E9809

CSA File #LR4503

See pages in back of catalog for complete tool information.

Tool and Die Selection Chart on page M42.

Maximum Electrical Rating: 105°C 600 Volts Max.

Terminal Material: Copper

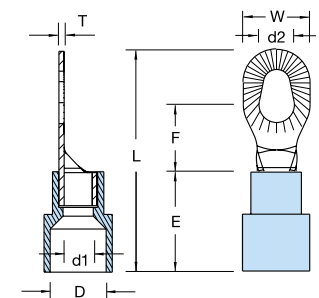

Tools used with Nylon and Vinyl Insulated Multiple Stud Ring Terminals



ERG2500



KT-2500

Thomas & Betts

Spec-Kon[®] Terminals



Non-Insulated Multiple Stud Ring Terminals

Catalog Number	Wire Range	Bolt Size	Dimension <small>inch mm</small>						
			W	F	L	E	D	d1	T
K18-610MS-M	22-16 A.W.G. 0.5-1.5 mm ²	#6 - #10	.339 8.6	.311 7.9	.768 19.5	.189 4.8	.134 3.4	.067 1.7	.030 0.75
K14-610MS-M	16-14 A.W.G. 1.5-2.5 mm ²	#6 - #10	.339 8.6	.311 7.9	.768 19.5	.189 4.8	.161 4.1	.091 2.3	.031 0.8
K10-610MS-M	12-10 A.W.G. 4-6 mm ²	#6 - #10	.390 9.9	.350 8.9	.886 22.5	.236 6.0	.220 5.6	.134 3.4	.039 1.0

- Single terminal for 6, 8, and 10 stud sizes
- Brazed Seam
- Chamfered Barrel
- Internal Barrel Serrations

Box Quantity: (M)=1000
For Mylar Tape replace box quantity with (T). Example: K18-610MS-T
UL File #E9809
CSA File #LR4503

Terminal Material: Copper

See pages in back of catalog for complete tool information.
Tool and Die Selection Chart on page M42.

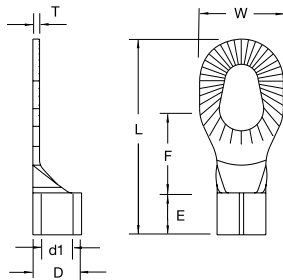

Tools used with Non-Insulated Multiple Stud Ring Terminals



ERG2002



KT-2500

M

Spec-Kon[®]

Thomas & Betts

Spec-Kon® Terminals



- Brazed Seam
- Molded Funnel Entry Insulator
- Internal Barrel Serrations

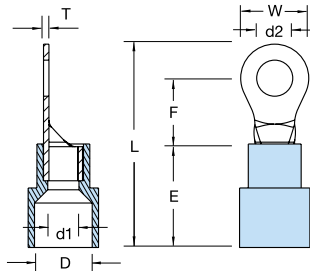

Nylon Insulated Large Ring Terminals



Catalog Number	Wire Range	Bolt Size (d2)	Dimension <small>inch mm</small>							
			W	F	L	E	D	d1	T	
KN8-8R-D	8 A.W.G. 8 mm ²	#8	.169 4.3	.315 8.0	.366 9.3	1.142 29.0	.630 16.0	.315 8.0	.177 4.5	.047 1.2
KN8-10R-D		#10	.209 5.3	.364 8.8	.429 10.9	1.232 31.3				
KN8-14R-D		1/4	.252 6.4	.472 12.0	.366 9.3	1.232 31.3				
KN8-516R-D		5/16	.331 8.4	.591 15.0	.543 13.8	1.469 37.3				
KN8-38R-D		3/8	.413 10.5	.591 15.0	.543 13.8	1.469 37.3				
KN8-12R-D		1/2	.512 13.0	.787 20.0	.591 15.0	1.614 41.0				
KN6-10R-W	6 A.W.G. 14 mm ²	#10	.209 5.3	.472 12.0	.524 13.3	1.606 40.8	.846 21.5	.433 11.0	.228 5.8	.059 1.5
KN6-14R-W		1/4	.252 6.4							
KN6-516R-W		5/16	.331 8.4	.630 16.0	.559 14.2	1.713 43.5				
KN6-38R-W		3/8	.413 10.5							
KN6-12R-W		1/2	.512 13.0	.866 22.0	.780 19.8	2.047 52.0				

Box Quantity: (W)=250; (D)=500
For mylar tape, replace box quantity with (T). Example: KN8-8R-T.

See pages in back of catalog for complete tool information.
Tool and Die Selection Chart on page M42.

Maximum Electrical Rating: 105°C 600 Volts Max.
Terminal Material: Copper

#8 AWG on mylar tape is UL Listed.
#6 AWG on mylar tape is UL Listed.

UL File #E9809
CSA File #LR4503



Spec-Kon®

Tools used with Nylon Insulated Large Ring Terminals



TBM6S

For tooling information for nylon insulated large ring terminals, see page M37.



KT-2500

Thomas & Betts

Spec-Kon® Terminals



- Brazed Seam
- Chamfered Barrel
- Internal Barrel Serrations

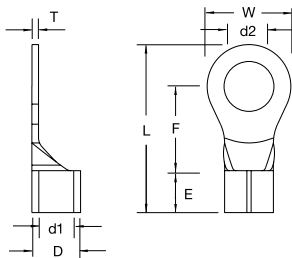

Non-Insulated Large Ring Terminals



Catalog Number	Wire Range	Bolt Size (d2)	Dimension <small>inch mm</small>							
			W	F	L	E	D	d1	T	
K8-8R-D	8 A.W.G. 8 mm ²	#8	.169 4.3	.315 8.0	.366 9.3	.846 21.5	.337 8.5	.283 7.2	.177 4.5	.047 1.2
K8-10R-D		#10	.209 5.3	.346 8.8	.429 10.5	.937 23.8				
K8-14R-D		1/4	.252 6.4	.472 12.0	.366 9.3	.937 23.8				
K8-516R-D		5/16	.331 8.4	.591 15.0	.543 13.8	1.161 29.8				
K8-38R-D		3/8	.413 10.5	.591 15.0	.543 13.8	1.161 29.8				
K8-12R-D		1/2	.512 13.0	.787 20.0	.591 15.0	1.319 33.5				
K6-10R-D	6 A.W.G. 14 mm ²	#10	.209 5.3	.472 12.0	.524 13.3	1.173 29.8	.413 10.5	.354 9.0	.228 5.85	.059 1.5
K6-14R-D		1/4	.252 6.4	.472 12.0	.524 13.3	1.173 29.8				
K6-516R-D		5/16	.331 8.4	.630 16.0	.559 14.2	1.280 32.5				
K6-38R-D		3/8	.413 10.5	.630 16.0	.559 14.2	1.280 32.5				
K6-12R-W		1/2	.512 13.0	.866 22.0	.780 19.8	1.614 41.0				
K4-8R-W*	4 A.W.G. 22 mm ²	#8	.169 4.3	.481 12.2	.594 15.1	1.307 33.2	.472 12.0	.453 11.5	.303 7.7	.067 1.7
K4-10R-W*		#10	.209 5.3	.481 12.2	.594 15.1	1.307 33.2				
K4-14R-W*		1/4	.252 6.4	.481 12.2	.594 15.1	1.299 33.0				
K4-516R-W*		5/16	.331 8.4	.650 16.5	.531 13.5	1.319 33.5				
K4-38R-W*		3/8	.413 10.5	.650 16.5	.531 13.5	1.319 33.5				
K4-12R-CC*		1/2	.512 13.0	.866 22.0	.776 19.7	1.661 42.5				
K2-10R-CC*	2 A.W.G. 38 mm ²	#10	.209 5.3	.602 15.3	.685 17.4	1.535 39.0	.551 14.0	.524 13.3	.370 9.4	.071 1.8
K2-14R-CC*		1/4	.252 6.4	.602 15.3	.685 17.4	1.535 39.0				
K2-516R-CC*		5/16	.331 8.4	.602 15.3	.685 17.4	1.535 39.0				
K2-38R-CC*		3/8	.413 10.5	.602 15.3	.685 17.4	1.535 39.0				
K2-12R-CC*		1/2	.512 13.0	.866 22.0	.697 17.7	1.681 42.7				



Box Quantity: C=100; CC=200; (W)=250; (D)=500;

For mylar tape, replace box quantity with (T). Example: K6-10R-T.
See pages in back of catalog for complete tool information.
Tool and Die Selection Chart on page M42.

Terminal Material: Copper

UL File #E9809
*Pending UL Listing

Tools used with Non-Insulated Large Ring Terminals



TBM6S

KT-2500

For tooling information for nylon insulated large ring terminals, see page M37.



Spec-Kon[®] Terminals



- Brazed Seam
- Internal Barrel Serrations

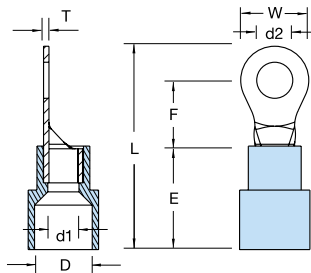

Vinyl Insulated Large Ring Terminals



Catalog Number	Wire Range	Bolt Size (d2)	Dimension <small>inch mm</small>							
			W	F	L	E	D	d1	T	
KV8-8R-D	8 A.W.G. 8 mm ²	#8	.169 4.3	.315 8.0	.366 9.3	1.16 29.5	.650 16.5	.335 8.5	.177 4.5	.047 1.2
KV8-10R-D		#10	.209 5.3	.346 8.8	.429 10.9	1.25 31.8				
KV8-14R-D		1/4	.252 6.4	.472 12.0	.366 9.3	1.25 31.8				
K8-516R-D		5/16	.331 8.4	.591 15.0	.543 13.8	1.49 37.8				
KV8-38R-D		3/8	.413 10.5	.591 15.0	.543 13.8	1.49 37.8				
KV8-12R-D		1/2	.512 13.0	.787 20.0	.591 15.0	1.63 41.5				
KV6-10R-W	6 A.W.G. 14 mm ²	#10	.209 5.3	.472 12.0	.524 13.3	1.62 41.2	.886 22.5	.414 10.5	.222 5.65	.059 1.5
KV6-14R-W		1/4	.252 6.4	.472 12.0	.524 13.3	1.62 41.2				
KV6-516R-W		5/16	.331 8.4	.630 16.0	.571 14.5	1.75 44.5				
KV6-38R-W		3/8	.413 10.5	.630 16.0	.571 14.5	1.75 44.5				
KV6-12R-W		1/2	.512 13.0	.866 22.0	.780 19.8	2.09 53				

Box Quantity: (W)=250; (D)=500
For mylar tape, replace box quantity with (T). Example: KN8-8R-T.

See pages in back of catalog for complete tool information.
Tool and Die Selection Chart on page M42.

Maximum Electrical Rating: 105°C 600 Volts Max.
Terminal Material: Copper

#8 AWG on mylar tape is UL Listed.
#6 AWG on mylar tape is UL Listed.

UL File #E9809
CSA File #LR4503

M

Spec-Kon[®]

Tools used with Vinyl Insulated Large Ring Terminals



TBM6S

For tooling information for nylon insulated large ring terminals, see page M37.



KT-2500

Thomas & Betts

Spec-Kon[®] Terminals



- Metal Insulation Sleeve
- Molded Insulator
- Internal Barrel Serrations
- Funnel Entry

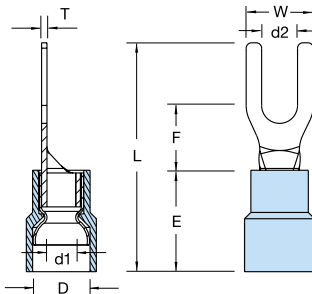

Nylon Insulated Fork Terminals



Catalog Number	Wire Range	Bolt Size (d2)	Dimension <small>inch mm</small>							
			W	F	L	E	D	d1	T	
KN18-6F-M	22-16 A.W.G. 0.5-1.5 mm ²	#6	.146 3.7	.252 6.4	.256 6.5	.866 22.0	.433 11.0	.177 4.5	.067 1.7	.030 0.75
KN18-8F-M		#8	.169 4.3	.252 6.4	.256 6.5	.866 22.0				
KN18-10F-M		#10	.209 5.3	.319 8.1	.256 6.5	.866 22.0				
KN18-14F-M		1/4	.252 6.4	.374 9.5	.256 6.5	.866 22.0				
KN14-6F-M	16-14 A.W.G. 1.5-2.5 mm ²	#6	.146 3.7	.236 6.0	.256 6.5	.866 22.0	.433 11.0	.205 5.2	.091 2.3	.031 0.8
KN14-8F-M		#8	.169 4.3	.252 6.4	.256 6.5	.866 22.0				
KN14-10F-M		#10	.209 5.3	.311 7.9	.256 6.5	.866 22.0				
KN14-14F-M		1/4	.252 6.4	.366 9.3	.256 6.5	.866 22.0				
KN10-6F-D	12-10 A.W.G. 4-6 mm ²	#6	.146 3.7	.283 7.2	.295 7.5	.961 24.4	.512 13.0	.276 7.0	.134 3.4	.039 1.0
KN10-8F-D		#8	.169 4.3	.327 8.3	.276 7.0	1.004 25.5				
KN10-10F-D		#10	.209 5.3	.354 9.0	.276 7.0	1.004 25.5				
KN10-14F-D		1/4	.252 6.4	.354 9.0	.276 7.0	1.004 25.5				
KN10-516F-D		5/16	.315 8.4	.551 14.0	.413 10.5	1.201 30.5				

Box Quantity: (D)=500; (M)=1000

For Mylar Tape replace box quantity with (T). Example: KN18-6F-T

UL File #E9809

CSA File #LR4503

See pages in back of catalog for complete tool information.

Tool and Die Selection Chart on page M42.

Maximum Electrical Rating: 105°C 600 Volts Max.

Terminal Material: Copper

M

Spec-Kon[®]

Tools used with Nylon Insulated Ring Terminals



ERG2500



KT-2500

Thomas & Betts



- Molded Funnel Entry Insulator
- Brazed Seam
- Internal Barrel Serrations

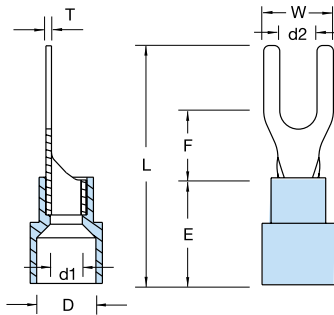

Vinyl Insulated Fork Terminals



Catalog Number	Wire Range	Bolt Size (d2)	Dimension <small>inch mm</small>							
			W	F	L	E	D	d1	T	
KV18-6F-M	22-16 A.W.G. 0.5-1.5 mm ²	#6	.146 3.7	.252 6.4	.256 6.5	.866 22.0	.433 11.0	.157 4.0	.067 1.7	.030 0.75
KV18-8F-M		#8	.169 4.3	.252 6.4	.256 6.5	.866 22.0				
KV18-10F-M		#10	.209 5.3	.319 8.1	.256 6.5	.866 22.0				
KV18-14F-M		1/4	.252 6.4	.374 9.5	.256 6.5	.866 22.0				
KV14-6F-M	16-14 A.W.G. 1.5-2.5 mm ²	#6	.146 3.7	.236 6.0	.256 6.5	.866 22.0	.433 11.0	.177 4.5	.091 2.3	.031 0.8
KV14-8F-M		#8	.169 4.3	.252 6.4	.256 6.5	.866 22.0				
KV14-10F-M		#10	.209 5.3	.311 7.9	.256 6.5	.866 22.0				
KV14-14F-M		1/4	.252 6.4	.366 9.3	.256 6.5	.866 22.0				
KV10-6F-D	12-10 A.W.G. 4-6 mm ²	#6	.146 3.7	.283 7.2	.295 7.5	.961 24.4	.512 13.0	.252 6.4	.134 3.4	.039 1.0
KV10-8F-D		#8	.169 4.3	.327 8.3	.276 7.0	1.004 25.5				
KV10-10F-D		#10	.209 5.3	.354 9.0	.276 7.0	1.004 25.5				
KV10-14F-D		1/4	.252 6.4	.354 9.0	.276 7.0	1.004 25.5				
KV10-516F-D		5/16	.315 8.4	.551 14.0	.413 10.5	1.201 30.5				

Box Quantity: (D)=500; (M)=1000
 For Mylar Tape replace box quantity with (T). Example: KV18-6F-T
 UL File #E9809
 CSA File #LR4503

See pages in back of catalog for complete tool information.
 Tool and Die Selection Chart on page M42.

Maximum Electrical Rating: 105°C 600 Volts Max.
 Terminal Material: Copper

Tools used with Vinyl Insulated Fork Terminals



ERG2500



KT-2500



Spec-Kon[®] Terminals



- Chamfered Barrel
- Brazed Seam
- Internal Barrel Serrations

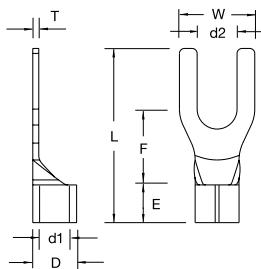

Non-Insulated Fork Terminals



Catalog Number	Wire Range	Bolt Size (d2)		Dimension <small>inch mm</small>							
				W	F	L	E	D	d1	T	
K18-6F-M	22-16 A.W.G. 0.5-1.5 mm ²	#6	.146 3.7	.252 6.4							
K18-8F-M		#8	.169 4.3	.252 6.4	.256 6.5	.630 16.0	.189 4.8	.134 3.4	.067 1.7	.030 0.75	
K18-10F-M		#10	.209 5.3	.319 8.1							
K14-6F-M	16-14 A.W.G. 1.5-2.5 mm ²	#6	.146 3.7	.236 6.0							
K14-8F-M		#8	.169 4.3	.252 6.4	.256 6.5	.630 16.0	.189 4.8	.161 4.1	.091 2.3	.031 0.8	
K14-10F-M		#10	.209 5.3	.319 8.1							
K10-6F-M	12-10 A.W.G. 4-6 mm ²	#6	.146 3.7	.283 7.2	.295 7.5	.685 17.4					
K10-8F-M		#8	.169 4.3	.327 8.3	.276 7.0	.728 18.5	.236 6.0	.220 5.6	.134 3.4	.039 1.0	
K10-10F-M		#10	.209 5.3	.354 9.0							
K10-14F-M		1/4	.252 6.4	.354 9.0							

Box Quantity: (M)=1000

For Mylar Tape replace box quantity with (T). Example: K18-6F-T

UL File #E9809

CSA File #LR4503

See pages in back of catalog for complete tool information.

Tool and Die Selection Chart on page M42.

Terminal Material: Copper

Tools used with Non-Insulated Fork Terminals



ERG2002



KT-2500

M

Spec-Kon[®]

Thomas & Betts

Spec-Kon[®] Terminals



- Metal Insulation Sleeve
- Molded Insulator
- Internal Barrel Serrations
- Funnel Entry

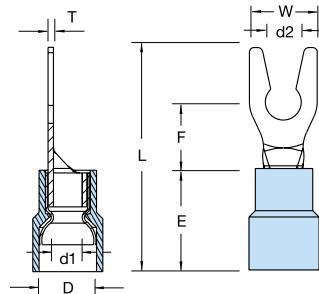

Nylon Insulated Locking Fork Terminals

Catalog Number	Wire Range	Bolt Size (d2)	Dimension <small>inch mm</small>							
			W	F	L	E	D	d1	T	
KN18-6LF-M	22-16 A.W.G. 0.5-1.5 mm ²	#6	.146 3.7	.252 6.4	.256 6.5	.866 22.0	.433 11.0	.177 4.5	.067 1.7	.030 0.75
KN18-8LF-M		#8	.169 4.3	.283 7.2						
KN18-10LF-M		#10	.209 5.3	.319 8.1						
KN14-6LF-M	16-14 A.W.G. 1.5-2.5 mm ²	#6	.146 3.7	.236 6.0	.256 6.5	.866 22.0	.433 11.0	.205 5.2	.091 2.3	.031 0.8
KN14-8LF-M		#8	.169 4.3	.283 7.2						
KN14-10LF-M		#10	.209 5.3	.319 8.1						
KN10-6LF-D	12-10 A.W.G. 4-6 mm ²	#6	.146 3.7	.327 8.3	.276 7.0	.992 25.2	.512 13.0	.276 7.0	.134 3.4	.039 1.0
KN10-8LF-D		#8	.169 4.3	.327 8.3						
KN10-10LF-D		#10	.209 5.3	.354 9.0						

Box Quantity: (D)=500; (M)=1000
For Mylar Tape replace box quantity with (T). Example: KN18-6LF-T
UL File #E9809, CSA File #LR4503

See pages in back of catalog for complete tool information.
Tool and Die Selection Chart on page M42.

Maximum Electrical Rating: 105°C 600 Volts Max.
Terminal Material: Copper



Vinyl Insulated Locking Fork Terminals

Catalog Number	Wire Range	Bolt Size (d2)	Dimension <small>inch mm</small>							
			W	F	L	E	D	d1	T	
KV18-6LF-M	22-16 A.W.G. 0.5-1.5 mm ²	#6	.146 3.7	.252 6.4	.256 6.5	.866 22.0	.433 11.0	.157 4.0	.067 1.7	.030 0.75
KV18-8LF-M		#8	.169 4.3	.283 7.2						
KV18-10LF-M		#10	.209 5.3	.319 8.1						
KV14-6LF-M	16-14 A.W.G. 1.5-2.5 mm ²	#6	.146 3.7	.236 6.0	.256 6.5	.866 22.0	.433 11.0	.177 4.5	.091 2.3	.031 0.8
KV14-8LF-M		#8	.169 4.3	.283 7.2						
KV14-10LF-M		#10	.209 5.3	.319 8.1						
KV10-6LF-D	12-10 A.W.G. 4-6 mm ²	#6	.146 3.7	.327 8.3	.276 7.0	.992 25.2	.512 13.0	.252 6.4	.134 3.4	.039 1.0
KV10-8LF-D		#8	.169 4.3	.327 8.3						
KV10-10LF-D		#10	.209 5.3	.354 9.0						

Box Quantity: (D)=500; (M)=1000
For Mylar Tape replace box quantity with (T).
Example: KV18-6LF-T
UL File #E9809, CSA File #LR4503

See pages in back of catalog for complete tool information.
Tool and Die Selection Chart on page M42.

Maximum Electrical Rating: 105°C 600 Volts Max.
Terminal Material: Copper

Tools used with Nylon and Vinyl Insulated Locking Fork Terminals



ERG2500

KT-2500

Thomas & Betts

Spec-Kon[®] Terminals



- Chamfered Barrel
- Brazed Seam
- Internal Barrel Serrations

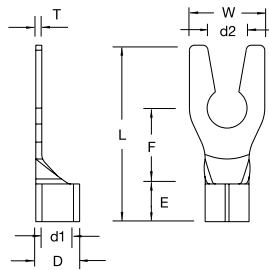

Non-Insulated Locking Fork Terminals



Catalog Number	Wire Range	Bolt Size (d2)		Dimension <small>inch mm</small>						
				W	F	L	E	D	d1	T
K18-6LF-M	22-16 A.W.G. 0.5-1.5 mm ²	#6	.146 3.7	.252 6.4	.256 6.5	.630 16.0	.189 4.8	.134 3.4	.067 1.7	.030 0.75
K18-8LF-M		#8	.169 4.3	.283 7.2						
K18-10LF-M		#10	.209 5.3	.319 8.1						
K14-6LF-M	16-14 A.W.G. 1.5-2.5 mm ²	#6	.146 3.7	.236 6.0	.256 6.5	.630 16.0	.189 4.8	.161 4.1	.091 2.3	.031 0.8
K14-8LF-M		#8	.169 4.3	.283 7.2						
K14-10LF-M		#10	.209 5.3	.319 8.1						
K10-6LF-M	12-10 A.W.G. 4-6 mm ²	#6	.146 3.7	.327 8.3	.276 7.0	.717 18.2	.236 6.0	.220 5.6	.134 3.4	.039 1.0
K10-8LF-M		#8	.169 4.3	.327 8.3						
K10-10LF-M		#10	.209 5.3	.354 9.0						

Box Quantity: (M)=1000

For Mylar Tape replace box quantity with (T). Example: K18-6LF-T

UL File #E9809

CSA File #LR4503

See pages in back of catalog for complete tool information.

Tool and Die Selection Chart on page M42.

Terminal Material: Copper

Tools used with Non-Insulated Locking Fork Terminals



ERG2002



KT-2500



Thomas & Betts

Spec-Kon® Terminals



- Reduces Slippage in High Vibration Applications
- Metal Insulation Sleeve
- Molded Insulator
- Internal Barrel Serrations
- Funnel Entry

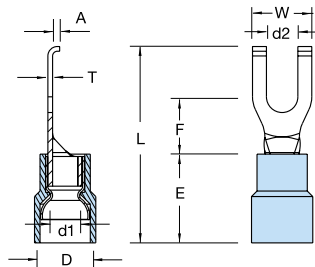

Nylon Insulated Flanged Fork Terminals



Catalog Number	Wire Range	Bolt Size (d2)	Dimension <small>inch mm</small>								
			W	F	L	E	D	d1	A	T	
KN18-6FF-M	22-16 A.W.G. 0.5-1.5 mm ²	#6	.146 3.7	.335 8.5	.283 7.2	1.004 25.5	.433 11.0	.177 4.5	.067 1.7	.059 1.5	.030 0.75
KN18-8FF-M		#8	.169 4.3	.335 8.5	.283 7.2	1.004 25.5					
KN18-10FF-M		#10	.209 5.3	.335 8.5	.283 7.2	1.004 25.5					
KN14-6FF-M	16-14 A.W.G. 1.5-2.5 mm ²	#6	.146 3.7	.335 8.5	.283 7.2	.945 24.0	.433 11.0	.205 5.2	.091 2.3	.059 1.5	.031 0.8
KN14-8FF-M		#8	.169 4.3	.335 8.5	.283 7.2	.945 24.0					
KN14-10FF-M		#10	.209 5.3	.335 8.5	.283 7.2	.945 24.0					
KN10-6FF-D	12-10 A.W.G. 4-6 mm ²	#6	.146 3.7	.335 8.5	.295 7.5	1.063 27.0	.512 13.0	.276 7.0	.134 3.4	.059 1.5	.039 1.0
KN10-8FF-D		#8	.169 4.3	.335 8.5	.295 7.5	1.063 27.0					
KN10-10FF-D		#10	.209 5.3	.335 8.5	.295 7.5	1.063 27.0					

Box Quantity: (D)=500; (M)=1000

For Mylar Tape replace box quantity with (T). Example: KN18-6FF-T

UL File #E9809, CSA File #LR4503

See pages in back of catalog for complete tool information.

Tool and Die Selection Chart on page M42.

Maximum Electrical Rating: 105°C 600 Volts Max.

Terminal Material: Copper

Vinyl Insulated Flanged Fork Terminals



Catalog Number	Wire Range	Bolt Size (d2)	Dimension <small>inch mm</small>								
			W	F	L	E	D	d1	A	T	
KV18-6FF-M	22-16 A.W.G. 0.5-1.5 mm ²	#6	.146 3.7	.252 6.4	.201 5.1	.787 20.0	.433 11.0	.157 4.0	.067 1.7	.059 1.5	.030 0.75
KV18-8FF-M		#8	.169 4.3	.335 8.5	.283 7.2	1.004 25.5					
KV18-10FF-M		#10	.209 5.3	.335 8.5	.283 7.2	1.004 25.5					
KV14-6FF-M	16-14 A.W.G. 1.5-2.5 mm ²	#6	.146 3.7	.335 8.5	.283 7.2	.945 24.0	.433 11.0	.177 4.5	.091 2.3	.059 1.5	.031 0.8
KV14-8FF-M		#8	.169 4.3	.335 8.5	.283 7.2	.945 24.0					
KV14-10FF-M		#10	.209 5.3	.335 8.5	.283 7.2	.945 24.0					
KV10-6FF-D	12-10 A.W.G. 4-6 mm ²	#6	.146 3.7	.299 7.6	.244 6.2	1.004 25.5	.512 13.0	.252 6.4	.134 3.4	.059 1.5	.039 1.0
KV10-8FF-D		#8	.169 4.3	.299 7.6	.244 6.2	1.004 25.5					
KV10-10FF-D		#10	.209 5.3	.299 7.6	.244 6.2	1.004 25.5					

Box Quantity: (D)=500; (M)=1000

For Mylar Tape replace box quantity with (T).

Example: KV18-6FF-T

UL File #E9809, CSA File #LR4503

See pages in back of catalog for complete tool information.

Tool and Die Selection Chart on page M42.

Maximum Electrical Rating: 105°C 600 Volts Max.

Terminal Material: Copper

Tools used with Nylon and Vinyl Insulated Flanged Fork Terminals



ERG2500

KT-2500

Thomas & Betts

Spec-Kon® Terminals



- Reduces Slippage in High Vibration Applications
- Chamfered Barrel
- Brazed Seam
- Internal Barrel Serrations

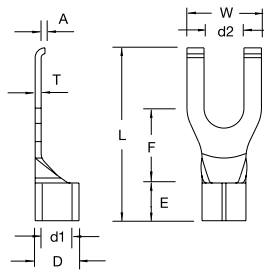

Non-Insulated Flanged Fork Terminals



Catalog Number	Wire Range	Bolt Size (d2)	Dimension <small>inch mm</small>								
			W	F	L	E	D	d1	A	T	
K18-6FF-M	22-16 A.W.G. 0.5-1.5 mm'	#6	.146 3.7	.335 8.5	.283 7.2	.768 19.5	.189 4.8	.134 3.4	.067 1.7	.059 1.5	.030 0.75
K18-8FF-M		#8	.169 4.3	.335 8.5	.283 7.2	.768 19.5					
K18-10FF-M		#10	.209 5.3	.335 8.5	.283 7.2	.768 19.5					
K14-6FF-M	16-14 A.W.G. 1.5-2.5 mm'	#6	.146 3.7	.335 8.5	.283 7.2	.709 18.0	.189 4.8	.161 4.1	.091 2.3	.059 1.5	.031 0.8
K14-8FF-M		#8	.169 4.3	.335 8.5	.283 7.2	.709 18.0					
K14-10FF-M		#10	.209 5.3	.335 8.5	.283 7.2	.709 18.0					
K10-6FF-M	12-10 A.W.G. 4-6 mm'	#6	.146 3.7	.335 8.5	.295 7.5	.787 20.0	.236 6.0	.220 5.6	.134 3.4	.059 1.5	.039 1.0
K10-8FF-M		#8	.169 4.3	.335 8.5	.295 7.5	.787 20.0					
K10-10FF-M		#10	.209 5.3	.335 8.5	.295 7.5	.787 20.0					

Box Quantity: (M)=1000

For Mylar Tape replace box quantity with (T). Example: K18-6FF-T

UL File #E9809

CSA File #LR4503

See pages in back of catalog for complete tool information.

Tool and Die Selection Chart on page M42.

Terminal Material: Copper

Tools used with Non-Insulated Flanged Fork Terminals



ERG2002



KT-2500



Thomas & Betts

Spec-Kon[®] Terminals



- For Use in DIN-Style Blade Terminal Blocks
- Metal Insulation Sleeve
- Molded Insulator
- Internal Barrel Serrations
- Funnel Entry

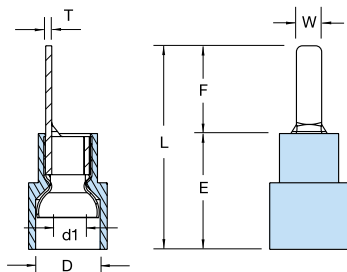

Nylon Insulated Blade Terminals



Catalog Number	Wire Range	Dimension <small>inch mm</small>						
		W	F	L	E	D	d1	T
KN18-10BL-M	22-16 A.W.G. 0.5-1.5 mm ²	.091 2.3	.394 10.0	.819 20.8	.433 11.0	.177 4.5	.067 1.7	.030 0.75
KN18-18BL-M		.087 2.2	.709 18.0	1.134 28.8				
KN14-10BL-M	16-14 A.W.G. 1.5-2.5 mm ²	.094 2.4	.394 10.0	.819 20.8	.433 11.0	.205 5.2	.091 2.3	.031 0.8
KN14-18BL-M		.087 2.2	.709 18.0	1.134 28.8				
KN10-10BL-D	12-10 A.W.G. 4-6 mm ²	.110 2.8	.394 10.0	.906 23.0	.512	.276	.134	.039

Box Quantity: (D)=500; (M)=1000

For Mylar Tape replace box quantity with (T). Example: KN18-10BL-T

UL File #E9809

CSA File #LR4503

See pages in back of catalog for complete tool information.

Tool and Die Selection Chart on page M42.

Maximum Electrical Rating: 105°C 600 Volts Max.

Terminal Material: Copper

Vinyl Insulated Blade Terminals



Catalog Number	Wire Range	Dimension <small>inch mm</small>						
		W	F	L	E	D	d1	T
KV18-10BL-M	22-16 A.W.G. 0.5-1.5 mm ²	.091 2.3	.394 10.0	.819 20.8	.433 11.0	.157 4.0	.067 1.7	.030 0.75
KV18-18BL-M		.087 2.2	.709 18.0	1.134 28.8				
KV14-10BL-M	16-14 A.W.G. 1.5-2.5 mm ²	.094 2.4	.394 10.0	.819 20.8	.433 11.0	.177 4.5	.091 2.3	.031 0.8
KV14-18BL-M		.087 2.2	.709 18.0	1.134 28.8				
KV10-10BL-D	12-10 A.W.G. 4-6 mm ²	.110 2.8	.394 10.0	.906 23.0	.512	.252	.134	.039

Box Quantity: (D)=500; (M)=1000

For Mylar Tape replace box quantity with (T). Example: KV18-10BL-T

UL File #E9809

CSA File #LR4503

See pages in back of catalog for complete tool information.

Tool and Die Selection Chart on page M42.

Maximum Electrical Rating: 105°C 600 Volts Max.

Terminal Material: Copper

Tools used with Nylon and Vinyl Insulated Blade Terminals



ERG2500



KT-2500

Thomas & Betts

Spec-Kon[®] Terminals



- For Use in Pin-Style Terminal Blocks
- Metal Insulation Sleeve
- Molded Insulator
- Internal Barrel Serrations
- Funnel Entry

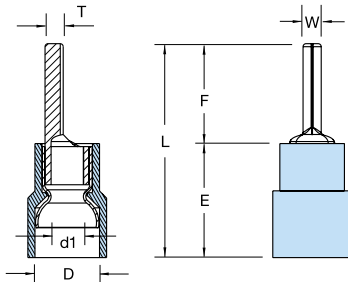

- For Use in Pin-Style Terminal Blocks
- Molded Funnel Entry Insulator
- Brazed Seams
- Internal Barrel Serrations

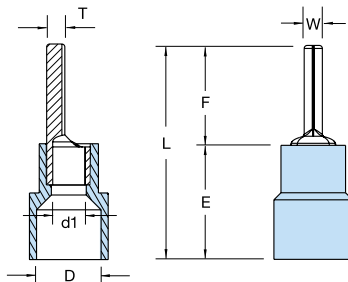

Nylon Insulated Pin Terminals



Catalog Number	Wire Range	Dimension <small>inch mm</small>						
		W	F	L	E	D	d1	T
KN18-12PT-M	22-16 A.W.G. 0.5-1.5 mm ²	.075	.472	.898	.433	.177	.067	.030
		1.9	12.0	22.8	11.0	4.5	1.7	0.75
KN14-12PT-M	16-14 A.W.G. 1.5-2.5 mm ²	.075	.472	.898	.433	.205	.091	.031
		1.9	12.0	22.8	11.0	5.2	2.3	0.8
KN10-14PT-D	12-10 A.W.G. 4-6 mm ²	.110	.551	1.063	.512	.276	.134	.039
		2.8	14.0	27.0	13.0	7.0	3.4	1.0

Box Quantity: (D)=500; (M)=1000

For Mylar Tape replace box quantity with (T). Example: KN18-12PT-T

UL File #E9809

CSA File #LR4503

See pages in back of catalog for complete tool information.

Tool and Die Selection Chart on page M42.

Maximum Electrical Rating: 105°C 600 Volts Max.

Terminal Material: Copper

Vinyl Insulated Pin Terminals



Catalog Number	Wire Range	Dimension <small>inch mm</small>						
		W	F	L	E	D	d1	T
KV18-12PT-M	22-16 A.W.G. 0.5-2.5 mm ²	.075	.472	.898	.433	.157	.067	.030
		1.9	12.0	22.8	11.0	4.0	1.7	0.75
KV14-12PT-M	16-14 A.W.G. 1.5-2.5 mm ²	.075	.472	.898	.433	.177	.091	.031
		1.9	12.0	22.8	11.0	4.5	2.3	0.8
KV10-14PT-D	12-10 A.W.G. 4-6 mm ²	.110	.551	1.063	.512	.252	.134	.039
		2.8	14.0	27.0	13.0	6.4	3.4	1.0

Box Quantity: (D)=500; (M)=1000

For Mylar Tape replace box quantity with (T). Example: KV18-12PT-T

UL File #E9809

CSA File #LR4503

See pages in back of catalog for complete tool information.

Tool and Die Selection Chart on page M42.

Maximum Electrical Rating: 105°C 600 Volts Max.

Terminal Material: Copper

Tools used with Nylon and Vinyl Insulated Pin Terminals



ERG2500



KT-2500

Thomas & Betts

M
Spec-Kon[®]

Spec-Kon® Disconnects



Features and Benefits

Nylon and Vinyl Disconnects

- **Sleeved barrel**—Ensures barrel does not separate during crimping.
- **Funnel entry insulators**—Funnel entry speeds installation and reduces wire hang up.
- **Partial and fully insulated**—Offers a wide range of products to meet virtually any application
- **Metal insulation sleeve**—Sleeve crimps wire insulation, providing high-vibration resistance and conductor strain relief.
- **Ratings**—UL Listed, cULus Listed, CSA, 600 V at 105°C for nylon and vinyl.

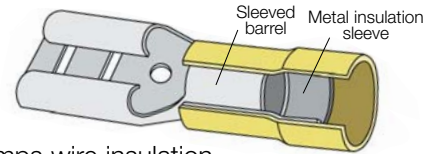

Design Features of Spec-Kon® Disconnects

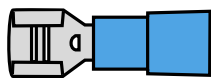

Female Disconnect

Provides easy installation and removal from male tabs and auxiliary equipment

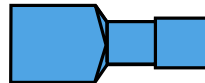

Fully Insulated Female

Standard female tab with the safety and reliability of complete insulation

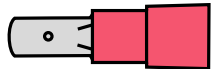

Male Disconnect

Tab-style male disconnects are fast and reliable

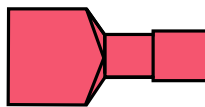

Fully Insulated Male

Standard male tab with the safety and reliability of complete insulation

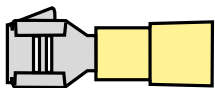

Female Piggy Back

Provides the option for multiple circuits using one termination point

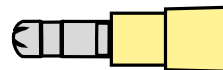

Bullet Disconnect and Receptacle

Fast and reliable alternative to the tab style featuring a lower profile to reduce space requirements

M

Spec-Kon®

Performance Requirements

Description	Wire Size (AWG)						
	#22	#20	#18	#16	#14	#12	#10
U.L. 310 (Disconnects)							
Test Current for Max. 30°C Rise (Amps)	3	4	7	10	15	20	24
Min. Tensile Strength* (Lbs.)	8	13	20	30	50	70	80

* Pull-out force of the crimped terminal.

Applicable Spec-Kon® products meet or exceed the following test specifications:

- UL310 (Disconnects)
- CSA

UL listed products are shown with the applicable logos in the product section.

UL file #E66716 (Disconnects).

CSA file #LR4503

Thomas & Betts

Spec-Kon[®] Disconnects



110 Tab Size



187 Tab Size



250 Tab Size

- For Use in Temporary Connections to Male Disconnects & Terminal Blocks
- Multiple Sizes for Range of Applications
- Metal Insulation Sleeve
- Molded Insulator
- Internal Barrel Serrations
- Funnel Entry

Nylon Insulated Female Disconnects



Catalog Number	Wire Range	Tab Size ^{inch}	Dimension ^{inch/mm}					
			W	F	L	B	D	T
KN18-110-20FD-M	22-16 A.W.G. 0.5-1.5 mm ²	.110 x .020	.126 3.2	.256 6.5	.772 19.6	.433 11.0	.157 4.0	.012 0.3
KN18-110-32FD-M		.110 x .032	.126 3.2	.256 6.5	.772 19.6			
KN18-187-20FD-M		.187 x .020	.197 5.0	.252 6.4	.787 20.0			.016 0.4
KN18-187-32FD-M		.187 x .032	.197 5.0	.252 6.4	.787 20.0			
KN18-250FD-M		.250 x .032	.260 6.6	.287 7.3	.846 21.5			
KN14-110-20FD-M	16-14 A.W.G. 1.5-2.5 mm ²	.110 x .020	.126 3.2	.252 6.4	.772 19.6	.433 11.0	.197 5.0	.012 0.3
KN14-110-32FD-M		.110 x .032	.126 3.2	.252 6.4	.772 19.6			
KN14-187-20FD-M		.187 x .020	.197 5.0	.256 6.5	.787 20.0			.016 0.4
KN14-187-32FD-M		.187 x .032	.197 5.0	.256 6.5	.787 20.0			
KN14-250FD-M		.250 x .032	.260 6.6	.287 7.3	.846 21.5			
KN10-110-20FD-D	12-10 A.W.G. 4-6 mm ²	.110 x .020	.126 3.2	.343 8.7	.866 22.0	.512 13.0	.256 6.5	.016 0.4
KN10-110-32-FD-D		.110 x .032	.126 3.2	.343 8.7	.866 22.0			
KN10-187-20FD-D		.187 x .020	.197 5.0	.256 6.5	.866 22.0			
KN10-187-32FD-D		.187 x .032	.197 5.0	.256 6.5	.866 22.0			
KN10-250FD-D		.250 x .032	.260 6.6	.287 7.3	.925 23.5			

Box Quantity: (D)=500; (M)=1000
For Mylar Tape replace box quantity with (T). Example: KN18-110FD-T
UL File #E66716
CSA File #LR4503

See pages in back of catalog for complete tool information.
Tool and Die Selection Chart on page M42.

Maximum Electrical Rating: 105°C 600 Volts Max.
Terminal Material: Brass with Copper Sleeve

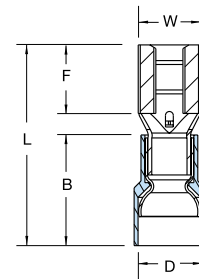

Tools used with Nylon Insulated Female Disconnects



ERG2500



KT-2500

Thomas & Betts

Spec-Kon® Disconnects

Vinyl Insulated Female Disconnects



110 Tab Size



187 Tab Size



250 Tab Size

Catalog Number	Wire Range	Tab Size inch	Dimension ^{inch} / _{mm}					
			W	F	L	B	D	T
KV18-110-20FD-M	22-16 A.W.G. 0.5-1.5 mm ²	.110 x .020	.126 3.2	.256 6.5	.728 19.0	.413 10.5	.150 3.8	.012 0.3
KV18-110-32FD-M		.110 x .032	.126 3.2	.256 6.5	.728 19.0			
KV18-187-20FD-M		.187 x .020	.197 5.0	.252 6.4	.764 19.4			.016 0.4
KV18-187-32FD-M		.187 x .032	.197 5.0	.252 6.4	.764 19.4			
KV18-250FD-M		.250 x .032	.260 6.6	.287 7.3	.819 20.8			
KV14-110-20FD-M	16-14 A.W.G. 1.5-2.5 mm ²	.110 x .020	.126 3.2	.256 6.5	.748 19.0	.413 10.5	.185 4.7	.012 0.3
KV14-110-32FD-M		.110 x .032	.126 3.2	.256 6.5	.748 19.0			
KV14-187-20FD-M		.187 x .020	.197 5.0	.252 6.4	.764 19.4			.016 0.4
KV14-187-32FD-M		.187 x .032	.197 5.0	.252 6.4	.764 19.4			
KV14-250FD-M		.250 x .032	.260 6.6	.287 7.3	.819 20.8			
KV10-110-20FD-D	12-10 A.W.G. 4-6 mm ²	.110 x .020	.126 3.2	.343 8.7	.866 22.0	.512 13.0	.244 6.2	.016 0.4
KV10-110-32FD-D		.110 x .032	.126 3.2	.343 8.7	.866 22.0			
KV10-187-20FD-D		.187 x .020	.197 5.0	.256 6.5	.866 22.0			.016 0.4
KV10-187-32FD-D		.187 x .032	.197 5.0	.256 6.5	.866 22.0			
KV10-250FD-D		.250 x .032	.260 6.6	.287 7.3	.917 23.3			

Box Quantity: (D)=500; (M)=1000

For Mylar Tape replace box quantity with (T). Example: KV18-110FD-T

UL File #E66716

CSA File #LR4503

See pages in back of catalog for complete tool information.
Tool and Die Selection Chart on page M42.

Maximum Electrical Rating: 105°C 300 Volts Max.
Terminal Material: Brass with Copper Sleeve

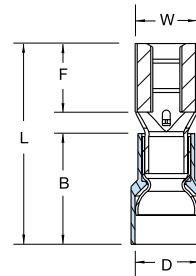

M

Spec-Kon®

- For Use in Temporary Connections to Male Disconnects & Terminal Blocks
- Metal Insulation Sleeve
- Easy Entry Copper Sleeve

Tools used with Vinyl Insulated Female Disconnects



ERG2500



KT-2500

Thomas & Betts

Spec-Kon[®] Disconnects



- For Use with Female Disconnects
- Metal Insulation Sleeve
- Molded Insulator
- Internal Barrel Serrations
- Funnel Entry

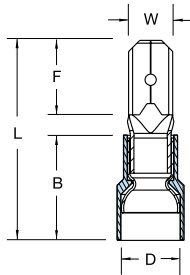

Nylon Insulated Male Disconnects



Catalog Number	Wire Range	Tab Size ^{inch}	Dimension ^{inch mm}					
			W	F	L	B	D	T
KN18-250MD-M	22-16 A.W.G. 0.5-1.5 mm ²	.250 x .032	.250 6.35	.303 7.7	.866 22.0	.413 11.0	.150 4.0	.016 0.4
KN14-250MD-M	16-14 A.W.G. 1.5-2.5 mm ²	.250 x .032	.250 6.35	.303 7.7	.866 22.0	.433 11.0	.197 5.0	.016 0.4
KN10-250MD-D	12-10 A.W.G. 4-6 mm ²	.250 x .032	.250 6.35	.303 7.7	.945 24.0	.512 13.0	.256 6.5	.016 0.4

Box Quantity: (D)=500; (M)=1000

For Mylar Tape replace box quantity with (T). Example: KN18-250MD-T

UL File #E66716

CSA File #LR4503

See pages in back of catalog for complete tool information.

Tool and Die Selection Chart on page M42.

Maximum Electrical Rating: 105°C 600 Volts Max.

Terminal Material: Brass with Copper Sleeve



- For Use with Female Disconnects
- Metal Insulation Sleeve
- Easy Entry Copper Sleeve

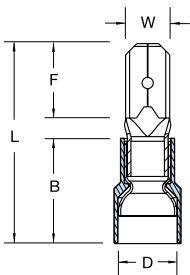

Vinyl Insulated Male Disconnects



Catalog Number	Wire Range	Tab Size ^{inch}	Dimension ^{inch mm}					
			W	F	L	B	D	T
KV18-250MD-M	22-16 A.W.G. 0.5-1.5 mm ²	.250 x .032	.250 6.35	.303 7.7	.858 21.8	.413 10.5	.150 3.8	.016 0.4
KV14-250MD-M	16-14 A.W.G. 1.5-2.5 mm ²	.250 x .032	.250 6.35	.303 7.7	.858 21.8	.413 10.5	.185 4.7	.016 0.4
KV10-250MD-D	12-10 A.W.G. 4-6 mm ²	.250 x .032	.250 6.35	.303 7.7	.945 24.0	.512 13.0	.244 6.2	.016 0.4

Box Quantity: (D)=500; (M)=1000

For Mylar Tape replace box quantity with (T). Example: KV18-250MD-T

UL File #E66716

CSA File #LR4503

See pages in back of catalog for complete tool information.

Tool and Die Selection Chart on page M42.

Maximum Electrical Rating: 105°C 300 Volts Max.

Terminal Material: Brass with Copper Sleeve

Tools used with Nylon and Vinyl Insulated Male Disconnects



ERG2500



KT-2500

Thomas & Betts

M
Spec-Kon[®]

Spec-Kon[®] Disconnects



- Male and Female Tabs Combined
- Additional conductors may be added to existing installations without changing blocks
- Metal Insulation Sleeve
- Molded Insulator
- Internal Barrel Serrations
- Funnel Entry

Nylon Insulated Piggy Back Disconnects

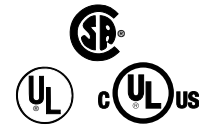

Catalog Number	Wire Range	Tab Size ^{inch}	Dimension ^{inch/mm}								
			W	W1	F	F1	L	B	D	T	
KN18-250PD-M	22-16 A.W.G. 0.5-1.5 mm ²	.250 x .032	.260 6.6	.250 6.35	.315 8.0	.323 8.2	.906 23.0	.433 11.0	.157 4.0	.016 0.4	
KN14-250PD-M	16-14 A.W.G. 1.5-2.5 mm ²	.250 x .032	.260 6.6	.250 6.35	.315 8.0	.323 8.2	.906 23.0	.433 11.0	.197 5.0	.016 0.4	
KN10-250PD-D	12-10 A.W.G. 4-6 mm ²	.250 x .032	.260 6.6	.250 6.35	.315 8.0	.323 8.2	.945 24.0	.512 13.0	.256 6.5	.016 0.4	

Box Quantity: (D)=500; (M)=1000
UL File #E66716
CSA File #LR4503

See pages in back of catalog for complete tool information.
Tool and Die Selection Chart on page M42.

Maximum Electrical Rating: 105°C 600 Volts Max.
Terminal Material: Brass with Copper Sleeve

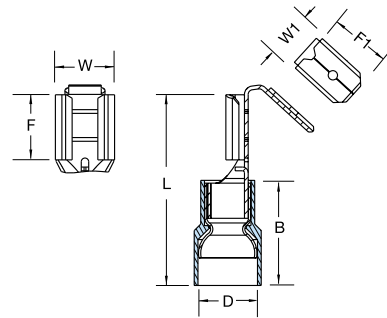

M

Spec-Kon[®]

- Male and Female Tabs Combined
- Additional conductors may be added to existing installations without changing blocks
- Brazed Seam
- Internal Barrel Serrations
- Funnel Entry

Vinyl Insulated Piggy Back Disconnects



Catalog Number	Wire Range	Tab Size ^{inch}	Dimension ^{inch/mm}								
			W	W1	F	F1	L	B	D	T	
KV18-250PD-M	22-16 A.W.G. 0.5-1.5 mm ²	.250 x .032	.260 6.6	.250 6.35	.315 8.0	.323 8.2	.886 22.5	.413 10.5	.150 3.8	.016 0.4	
KV14-250PD-M	16-14 A.W.G. 1.5-2.5 mm ²	.250 x .032	.260 6.6	.250 6.35	.315 8.0	.323 8.2	.886 22.5	.413 10.5	.185 4.7	.016 0.4	
KV10-250PD-D	12-10 A.W.G. 4-6 mm ²	.250 x .032	.260 6.6	.250 6.35	.315 8.0	.323 8.2	.945 24.0	.512 13.0	.244 6.2	.016 0.4	

Box Quantity: (D)=500; (M)=1000
UL File #E66716
CSA File #LR4503

See pages in back of catalog for complete tool information.
Tool and Die Selection Chart on page M42.

Maximum Electrical Rating: 105°C 300 Volts Max.
Terminal Material: Brass with Copper Sleeve

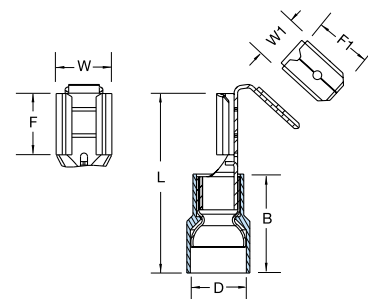

Tools used with Nylon and Vinyl Insulated Piggy Back Disconnects



ERG2500



KT-2500

Thomas & Betts

Spec-Kon[®] Disconnects

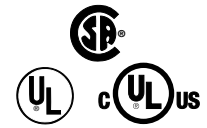

Nylon Fully Insulated Female Disconnects



110 Tab Size

187 Tab Size

250 Tab Size

Catalog Number	Wire Range	Tab Size ^{inch}	Dimension ^{inch/mm}					
			W	F	L	B	D	T
KNF18-110-20FDM	22-16 A.W.G. 0.5-1.5 mm ²	.110 x .020	.126 3.2	.252 6.4	.756 19.2			.012 0.3
KNF18-110-32FDM		.110 x .032	.126 3.2	.252 6.4	.756 19.2			
KNF18-187-20FDM		.187 x .020	.197 5.0	.256 6.5	.795 20.2	.433 11.0	.157 4.0	.016 0.4
KNF18-187-32FDM		.187 x .032	.197 5.0	.256 6.5	.795 20.2			
KNF18-250FD-D		.250 x .032	.260 6.6	.303 7.7	.846 21.5	.433 11.0	.256 6.0	.016 0.4
KNF14-187-20FDM		16-14 A.W.G. 1.5-2.5 mm ²	.187 x .020	.197 5.0	.256 6.5			
KNF14-187-32FDM	.187 x .032		.197 5.0	.256 6.5	.795 20.2			
KNF14-250FD-M	.250 x .032	.260 6.6	.287 7.3	.846 21.5				
KNF10-250FD-D	12-10 A.W.G. 4-6 mm ²	.250 x .032	.260 6.6	.287 7.3	.953 24.2	.512 13.0	.256 6.5	.016 0.4

Box Quantity: (D)=500; (M)=1000
 For Mylar Tape replace box quantity with (T). Example: KNF18-110-20FD-T
 UL File #E66716
 CSA File #LR4503

See pages in back of catalog for complete tool information.
 Tool and Die Selection Chart on page M42.

Maximum Electrical Rating: 105°C 600 Volts Max.
 Terminal Material: Brass with Copper Sleeve

- Fully Insulated
- Metal Insulation Sleeve
- Molded Insulator
- Internal Barrel Serrations
- Funnel Entry

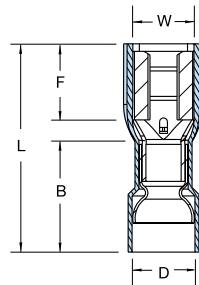

Tools used with Nylon Fully Insulated Female Disconnects



ERG2500



KT-2500

Thomas & Betts



Spec-Kon[®] Disconnects



Vinyl Fully Insulated Female Disconnects



110 Tab Size



187 Tab Size



250 Tab Size

- Fully Insulated
- Brazed Seam
- Internal Barrel Serrations
- Funnel Entry

Catalog Number	Wire Range	Tab Size inch	Dimension ^{inch} / _{mm}					
			W	F	L	B	D	T
KVF18-110-20FDM	22-16 A.W.G. 0.5-1.5 mm ²	.110 x .020	.126 3.2	.256 6.5	.748 19.0	.413 10.5	.150 3.8	.012 0.3
KVF18-110-32FDM		.110 x .032	.126 3.2	.256 6.5	.748 19.0			
KVF18-187-20FDM		.187 x .020	.197 5.0	.252 6.4	.807 20.5			.016 0.4
KVF18-187-32FDM		.187 x .032	.197 5.0	.252 6.4	.807 20.5			
KVF18-250FD-M		.250 x .032	.260 6.6	.287 7.3	.858 21.8			
KVF14-110-20FDM	16-14 A.W.G. 1.5-2.5 mm ²	.110 x .020	.126 3.2	.256 6.5	.748 19.0	.413 10.5	.185 4.7	.012 0.3
KVF14-110-32FDM		.110 x .032	.126 3.2	.256 6.5	.748 19.0			
KVF14-187-20FDM		.187 x .020	.197 5.0	.252 6.4	.796 20.2			.016 0.4
KVF14-187-32FDM		.187 x .032	.197 5.0	.252 6.4	.796 20.2			
KVF14-250FD-M		.250 x .032	.260 6.6	.287 7.3	.874 22.2			
KVF10-250FD-D	12-10 A.W.G. 4-6 mm ²	.250 x .032	.260 6.6	.287 7.3	.953 24.2	.492 12.5	.244 6.2	.016 0.4

Box Quantity: (D)=500; (M)=1000

For Mylar Tape replace box quantity with (T). Example: KVF18-110-20FD-T

UL File #E66716

CSA File #LR4503

See pages in back of catalog for complete tool information.

Tool and Die Selection Chart on page M42.

Maximum Electrical Rating: 105°C 300 Volts Max.

Terminal Material: Brass with Copper Sleeve

Tools used with Vinyl Fully Insulated Female Disconnects: ERG2500 and KT2500.

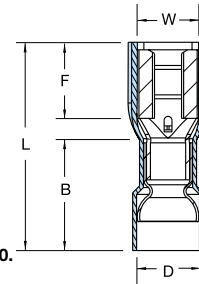

M

Spec-Kon[®]



- Fully Insulated
- Metal Insulation Sleeve
- Molded Insulator
- Internal Barrel Serrations
- Funnel Entry

Nylon Fully Insulated Male Disconnects



Catalog Number	Wire Range	Tab Size inch	Dimension ^{inch} / _{mm}					
			W	F	L	B	D	T
KNF18-250MD-D	22-16 A.W.G. 0.5-1.5 mm ²	.250 x .032	.250 6.35	.303 7.7	.976 24.0	.433 11.0	.157 4.0	.016 0.4
KNF14-250MD-D	16-14 A.W.G. 1.5-2.5 mm ²	.250 x .032	.250 6.35	.303 7.7	.976 24.0	.433 11.0	.197 5.0	.016 0.4
KNF10-250MD-D	12-10 A.W.G. 4-6 mm ²	.250 x .032	.250 6.35	.303 7.7	1.016 25.8	.512 13.0	.256 6.5	.016 0.4

Box Quantity: (D)=500

UL File #E66716

CSA File #LR4503

See pages in back of catalog for complete tool information.

Tool and Die Selection Chart on page M42.

Maximum Electrical Rating: 105°C 600 Volts Max.

Terminal Material: Brass with Copper Sleeve

Yellow Male Disconnect Not Shown.

Tools used with Nylon Fully Insulated Male Disconnects: ERG2500 and KT2500.

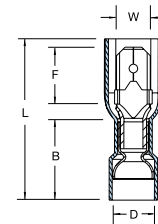

Thomas & Betts

Spec-Kon[®] Disconnects



- Fully Insulated
- Molded Funnel Entry Insulator
- Internal Barrel Serrations

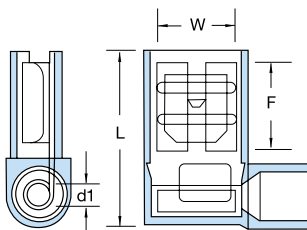

Nylon Fully Insulated Female Flag Disconnects

Catalog Number	Wire Range	Tab Size ^{inch}	Dimension ^{inch/mm}				
			W	F	L	d1	T
KNF18-187-20FFD-M	22-18 A.W.G. 0.5-1.5 mm ²	.187 x .020	.197 5.0	.276 7.0	.591 15.0	.063 1.6	.016 0.4
KNF18-187-32FFD-M		.187 x .032	.197 5.0	.276 7.0	.591 15.0		
KNF18-250FFD-M		.250 x .032	.260 6.6	.299 7.6	.598 15.2		
KNF14-187-20FFD-M	16-14 A.W.G. 1.5-2.5 mm ²	.187 x .020	.197 5.0	.276 7.0	.598 15.2	.083 2.1	.016 0.4
KNF14-187-32FFD-M		.187 x .032	.197 5.0	.276 7.0	.598 15.2		
KNF14-250FFD-M		.250 x .032	.260 6.6	.299 7.6	.598 15.2		

Box Quantity: (W)=250; (D)=500; (M)=1000

See pages in back of catalog for complete tool information.
Tool and Die Selection Chart on page M42.

Maximum Electrical Rating: 105°C 300 Volts Max.
Terminal Material: Brass



- Fully Insulated
- Molded Funnel Entry Insulator
- Internal Barrel Serrations

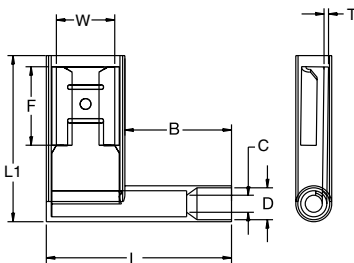

Nylon Fully Insulated Barrel Flag Female Disconnects



Catalog Number	Wire Range	Tab Size ^{inch}	Dimension ^{inch/mm}						
			W	F	L	L 1	B	D	T
KNF18-187-20BFD-D	22-18 A.W.G. 0.5-1.5 mm ²	.187 x .020	.197 5.0	.244 6.2	.748 19.0	.555 14.1	.433 11.0	.137 3.5	.015 0.4
KNF18-187-32BFD-D		.187 x .032	.197 5.0	.244 6.2	.748 19.0	.555 14.1	.433 11.0	.137 3.5	.015 0.4
KNF18-250BFD-D		.250 x .032	.260 6.6	.307 7.8	.818 20.8	.653 16.6	.433 11.0	.157 4.0	.015 0.4
KNF14-250BFD-D	16-14 A.W.G.	.250 x .032	.260 6.6	.307 7.8	.818 20.8	.653 16.6	.433 11.0	.177 4.5	.015 0.4
KNF10-250BFD-D	12-10 A.W.G.	.250 x .032	.260 6.6	.307 7.8	.905 23.0	.697 17.7	.511 13.0	.248 6.3	.015 0.4

Box Quantity: (W)=250; (D)=500; (M)=1000
For Mylar Tape replace box quantity with (T).
Example: KVF18-110-20FD-T

Tool and Die Selection Chart on page M42.
Maximum Electrical Rating: 105°C 600 Volts Max.
Terminal Material: Brass

See pages in back of catalog for complete tool information.

Tools used with Nylon Fully Insulated Female Flag Disconnects and Nylon Fully Insulated Barrel Flag Female Disconnects: ERG2500F



Spec-Kon[®] Disconnects



- Fully Insulated
- Metal Insulation Sleeve
- Molded Insulator
- Internal Barrel Serrations
- Funnel Entry

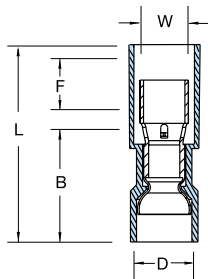

Nylon Fully Insulated Bullet Receptacles



Catalog Number	Wire Range	Dimension <small>inch mm</small>					
		W	F	L	B	D	T
KNF18-4FB-M	22-16 A.W.G. 0.5-1.5 mm ²	.153	.287	.992	.433	.157	.016
		3.9	7.3	25.2	11.0	4.0	0.4
KNF14-4FB-M	16-14 A.W.G. 1.5-2.5 mm ²	.153	.287	.992	.433	.197	.016
		3.9	7.3	25.2	11.0	5.0	0.4

Box Quantity: (M)=1000

For Mylar Tape replace box quantity with (T). Example: KNF18-4FB-T

UL File #E66716

CSA File #LR4503

See pages in back of catalog for complete tool information.

Tool and Die Selection Chart on page M42.

Maximum Electrical Rating: 105°C 600 Volts Max.

Terminal Material: Brass with Copper Sleeve

Vinyl Fully Insulated Bullet Receptacles



Catalog Number	Wire Range	Dimension <small>inch mm</small>					
		W	F	L	B	D	T
KVF18-4FB-M	22-16 A.W.G. 0.5-1.5 mm ²	.153	.287	.917	.413	.150	.016
		3.9	7.3	23.3	10.5	3.8	0.4
KVF14-4FB-M	16-14 A.W.G. 1.5-2.5 mm ²	.153	.287	.917	.413	.185	.016
		3.9	7.3	23.3	10.5	4.7	0.4
KVF10-5FB-D*	12-10 A.W.G. 4-6 mm ²	.193	.276	.988	.492	.244	.018
		4.9	7.0	25.1	12.5	6.2	0.45

*Not UL listed

Box Quantity: (D)=500; (M)=1000

For Mylar Tape replace box quantity with (T). Example: KVF18-4FB-T

UL File #E66716

CSA File #LR4503

See pages in back of catalog for complete tool information.

Tool and Die Selection Chart on page M42.

Maximum Electrical Rating: 75°C 300 Volts Max.

Terminal Material: Brass with Copper Sleeve

Tools used with Nylon and Vinyl Insulated Bullet Receptacles



ERG2500



KT-2500

Thomas & Betts

Spec-Kon® Disconnects



- Fully Insulated
- Metal Insulation Sleeve
- Molded Insulator
- Internal Barrel Serrations
- Funnel Entry

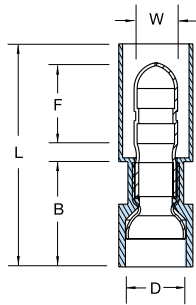

- Brazed Seam
- Internal Barrel Serrations
- Funnel Entry

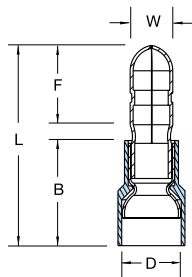

Nylon Fully Insulated Bullet Disconnects

Catalog Number	Wire Range	Dimension <small>inch mm</small>					
		W	F	L	B	D	T
KNF18-4MB-D	22-16 A.W.G. 0.5-1.5 mm ²	.157	.413	1.063	.394	.157	.016
		4.0	10.5	27.0	10.0	4.0	0.4
KNF14-4MB-D	16-14 A.W.G. 1.5-2.5 mm ²	.157	.413	1.063	.394	.177	.016
		4.0	10.5	27.0	10.0	4.5	0.4

Box Quantity: (D)=500

For Mylar Tape replace box quantity with (T). Example: KNF18-4MB-T

See pages in back of catalog for complete tool information.
Tool and Die Selection Chart on page M42.

Maximum Electrical Rating: 105°C 600 Volts Max.
Terminal Material: Brass with Copper Sleeve

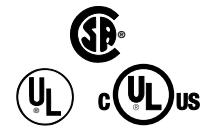

Vinyl Insulated Bullet Disconnects

Catalog Number	Wire Range	Dimension <small>inch mm</small>					
		W	F	L	B	D	T
KV18-4MB-M	22-16 A.W.G. 0.5-1.5 mm ²	.157	.413	9.25	.413	.150	.016
		4.0	10.5	23.5	10.5	3.8	0.4
KV14-4MB-M	16-14 A.W.G. 1.5-2.5 mm ²	.157	.413	9.25	.413	.185	.016
		4.0	10.5	23.5	10.5	4.7	0.4
KV10-5MB-D	12-10 A.W.G. 4-6 mm ²	.197	.335	.945	.512	.244	.016
		5.0	8.5	24.0	13.0	6.2	0.4

Box Quantity: (D)=500

For Mylar Tape replace box quantity with (T). Example: KV18-4MB-T

UL File #E66716

CSA File #LR4503

See pages in back of catalog for complete tool information.
Tool and Die Selection Chart on page M42.

Maximum Electrical Rating: 75°C 300 Volts Max.
Terminal Material: Brass with Copper Sleeve

Tools used with Nylon and Vinyl Insulated Bullet Disconnects



ERG2500



KT-2500

Thomas & Betts

Spec-Kon®

Splices, Wire Joints, and Quick Splices

Features and Benefits

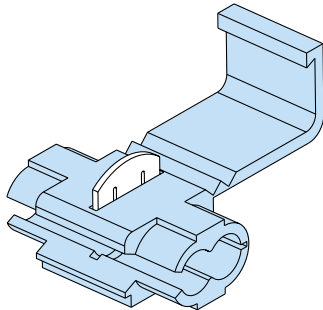

Splices / Wire Joints / Quick Splices

- Ideal for in-line splicing.
- Butt Splices available in Nylon, Vinyl, and non-insulated types.
- Vinyl Quick Splices are color-coded for wire ranges, and provide quick, easy in-line splicing and tapping.
- Nylon wire joint provides long-lasting, durable connection and can accommodate multiple leads. Rated 300 V at 105°C.
- Available in 22-10 AWG.

Design Features of Splices, Wire Joints and Quick Splices



Butt Splice

Ideal for in-line splicing applications

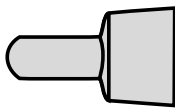

Wire Joints

Provides terminating point for a group of wires running in one direction

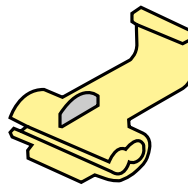

Quick Splices

Great for quick in-line splicing and tapping without stripping the wire insulation

Performance Requirements

M

Spec-Kon®

Description	Wire Size (AWG)										
	#22	#20	#18	#16	#14	#12	#10	#8	#6	#4	#2
U.L. 486A (Terminals)											
Test Current for Max. 50°C Rise (Amps)	9	12	17	18	30	35	50	70	95	125	145
Min. Tensile Strength* (Lbs.)	8	13	20	30	50	70	80	90	100	140	160

* Pull-out force of the crimped terminal.

Applicable Spec-Kon® products meet or exceed the following test specifications:

- UL486A (Terminals)
- CSA
- UL486C (Splices)

UL listed products are shown with the applicable logos in the product section.

UL file #E9809 (Terminals).

CSA file #LR4503

Thomas & Betts

Spec-Kon®

Splices, Wire Joints, and Quick Splices



- Internal Wire Stop
- Brazed Seams (Yellow - Tubular)
- Chamfered Funnel Entry

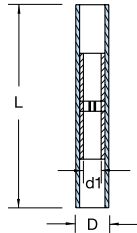

Nylon Insulated Butt Splice



Catalog Number	Wire Range	Dimension <small>inch mm</small>		
		L	D	d1
KN18-BS-M	22-16 A.W.G. 0.5-1.5 mm ²	1.075	.126	.067
		27.3	3.2	1.7
KN14-BS-M	16-14 A.W.G. 1.5-2.5 mm ²	1.075	.150	.091
		27.3	3.8	2.3
KN10-BS-D	12-10 A.W.G. 4-6 mm ²	1.110	.248	.134
		28.2	6.3	3.4

Box Quantity: (W)=250; (D)=500; (M)=1000

See pages in back of catalog for complete tool information.
 Tool and Die Selection Chart on page M42.
 UL File #9809
 CSA File #LR4503

Maximum Electrical Rating: 105°C 600 Volts Max.
Connector Material: Copper



- Expanded Entry
- Brazed Seams (Yellow - Tubular)
- Internal Barrel Serrations

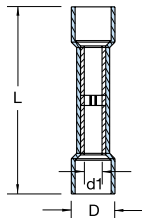

Vinyl Insulated Butt Splice



Catalog Number	Wire Range	Dimension <small>inch mm</small>		
		L	D	d1
KV18-BS-M	22-16 A.W.G. 0.5-1.5 mm ²	.986	.157	.067
		24.6	4.0	1.7
KV14-BS-M	16-14 A.W.G. 1.5-2.5 mm ²	.986	.177	.091
		24.6	4.5	2.3
KV10-BS-D	12-10 A.W.G. 4-6 mm ²	1.024	2.48	1.34
		26.0	6.3	3.4

Box Quantity: (W)=250; (D)=500; (M)=1000
 UL File #E9809
 CSA File #LR4503

See pages in back of catalog for complete tool information.
 Tool and Die Selection Chart on page M42.

Maximum Electrical Rating: 75°C 600 Volts Max.
Terminal Material: Copper

Tool used with Nylon and Vinyl Insulated Butt Splice



ERG2500

Thomas & Betts

M
Spec-Kon®

Spec-Kon®

Splices, Wire Joints, and Quick Splices



- Chamfered Barrel Entry
- Seamless Barrel Construction
- Wire Stop

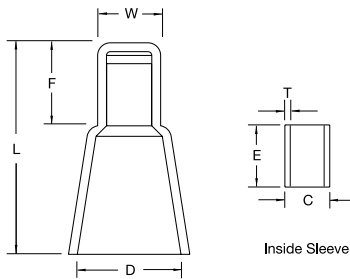
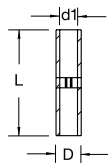

M

Spec-Kon®

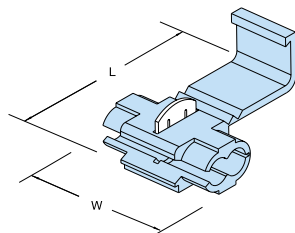

M34

Non-Insulated Butt Splice



Catalog Number	Wire Range	Dimension <small>inch mm</small>			
		L	D	d1	T
K18-BS-M	22-16 A.W.G. 0.5-1.5 mm ²	.591	.130	.067	.031
		15.0	3.3	1.7	0.8
K14-BS-M	16-14 A.W.G. 1.5-2.5 mm ²	.591	.154	.091	.031
		15.0	3.9	2.3	0.8
K10-BS-M	12-10 A.W.G. 4-6 mm ²	.591	.213	.134	.039
		15.0	5.4	3.4	1.0

Box Quantity: (M)=1000
UL File #E9809
CSA File #LR4503

Tool used with Non-Insulated Butt Splice

See pages in back of catalog for complete tool information.
Tool and Die Selection Chart on page M42.



ERG2002

Terminal Material: Copper Tubular

Nylon Insulated Wire Joint



Catalog Number	Wire Range	Dimension <small>inch mm</small>						
		W	F	L	D	E	T	C
KN18-WJ-M	22-16 A.W.G. 1.25 mm ²	.209	.315	.827	.386	.276	.020	.091
		5.3	8.0	21.0	9.8	7.0	0.5	2.3
KN14-WJ-M	16-14 A.W.G. 2 mm ²	.236	.354	.827	.394	.276	.020	.122
		6.0	9.0	21.0	10.0	7.0	0.5	3.1
KN10-WJ-D	12-10 A.W.G. 5.5 mm ²	.299	.394	1.004	.492	.295	.028	.157
		7.6	10.0	25.5	12.5	7.5	0.7	4.0

Box Quantity: (W)=250; (D)=500; (M)=1000
UL File #E66716
CSA File #LR4503

Tool used with Nylon Insulated Wire Joint

See pages in back of catalog for complete tool information.
Tool and Die Selection Chart on page M42.



ERG2500WJ

Maximum Electrical Rating: 105°C 300 Volts Max.
Terminal Material: Copper Tube

Vinyl Insulated Quick Splice

Catalog Number	Wire Range	Dimension <small>inch mm</small>		
		W	L	Color
KV14-OOQS-D	22-18 A.W.G. 0.5-1.0 mm ²	.787	1.063	red
		20.0	27.0	
KV18-OOQS-D	18-14 A.W.G. .75-2.5 mm ²	.787	1.063	blue
		20.0	27.0	
KV10-OOQS*	12-10 A.W.G. 4-6 mm ²	.807	1.358	yellow
		20.5	34.5	

Box Quantity: (W)=250; (D)=500; (M)=1000
* 200 piece quantity only.

See pages in back of catalog for complete tool information.
Tool and Die Selection Chart on page M42.

Maximum Electrical Rating: 105°C 600 Volts Max.
Terminal Material: Brass

Thomas & Betts

Spec-Kon® Hand Tools



ERG2500



ERG2002



ERG2500WJ

Comfort Crimp® Terminal Tools ERG-2500, ERG-2500F, ERG-2002, ERG-2500WJ

Ergonomic ratchet style hand tool used for installing insulated Spec-Kon® terminals. Specially designed ergonomic handles distributes the crimping force evenly across the user's hands. Helps reduce the risk of Carpal Tunnel Syndrome, the cause of almost one of every two industrial injuries. Ratchet design greatly reduces handle forces over conventional hand tools and incorporates the Shure-Stake® mechanism which ensures full compression every time. Color coded die nests (insulated only) facilitates getting the right terminal in the right nest.

Catalog Number	Terminal Style	Wire Range
ERG-2500	All Insulated Terminals, Splices, & Disconnects (except Flags)	22 - 10 AWG
ERG-2002	All Non-Insulated Terminals, Splices, & Disconnects	22 - 10 AWG
ERG-2500F	Nylon Fully Insulated Female Flag Disconnects	22 - 14 AWG
ERG-2500WJ	Nylon Insulated Wire Joint	22 - 10 AWG

* Contact Customer Service for availability of this product. Longer lead times may be required.

Tool Gauging Requirements

Catalog Number	Wire Range	Gauging (inches)
ERG-2500	22 - 16 AWG	.080 - .088
	16 - 14 AWG	.091 - .099
	12 - 10 AWG	.119 - .127
ERG-2002	22 - 16 AWG	.067 - .062
	16 - 14 AWG	.089 - .084
	12 - 10 AWG	.115 - .110
ERG-2500F	22 - 14 AWG	-
ERG-2500WJ	22 - 10 AWG	-

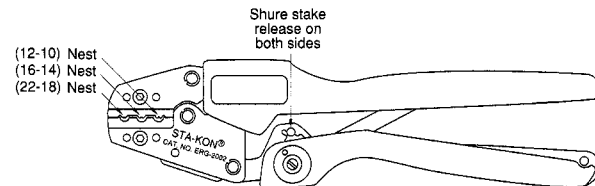
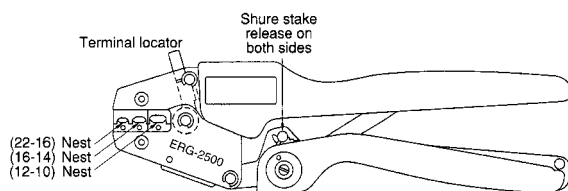

- Installs Nylon and Vinyl Insulated Terminals, Disconnects, and Splices 22-10 AWG
- The force required to release the Shure-Stake® mechanism should be no less than 20 lbs.

- Installs Non-Insulated Terminals, Disconnects, and Splices 22-10 AWG
- The force required to release the Shure-Stake® mechanism should be no less than 15 lbs.



Thomas & Betts

Spec-Kon® Hand Tools

Plier Type Tools WT111M and WT112M



WT111M



WT112M

Economical plier type hand tool used for installing non-insulated and insulated Spec-Kon® terminals. Range of sizes include 22 AWG through 10 AWG. Nose of the tool is equipped with wire cutters for convenience.

Catalog Number	Description	Std. Pkg	Wt. each
WT111M	Non-Insulated Plier Tool with Cutter for 22-10 AWG	1	1
WT112M	Insulated and Non-Insulated Plier Tool with Cutter for 22-10 AWG	1	1

- These tools are designed with wire cutters for customer convenience.

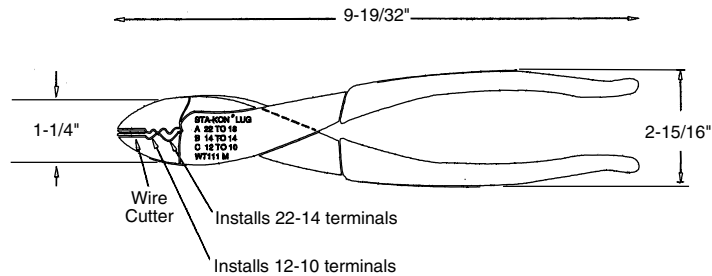

- WT111M - Installs 22-10 AWG non-insulated Spec-Kon® Terminals
- Gauging for 22-14 AWG 0.027 - 0.053 in.
- Gauging for 12-10 AWG 0.072 - 0.098 in.

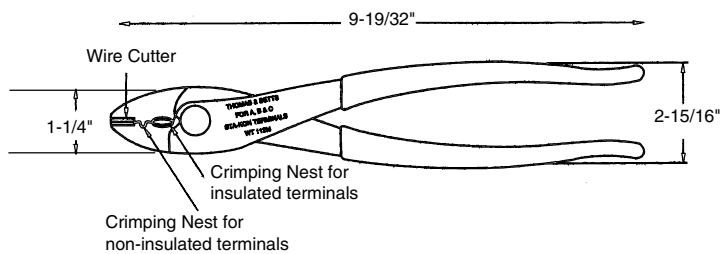

- WT112 M - Installs insulated and non-insulated Spec-Kon® terminals, splices, disconnects, and wire joints 22-10 AWG
- Gauging for insulated terminals .092 - .104
- Gauging for non-insulated terminals .044 - .056



Spec-Kon®

Thomas & Betts

Spec-Kon® Hand Tools



TBM6



TBM6S

Toggle Type Tools TBM6 and TBM6S

Toggle type hand tool for installing large insulated and non-insulated Spec-Kon® terminals. Terminal size ranges from #8 AWG through #2 AWG MCM. Interchangeable dies are ordered separately. The TBM6S features the Shure-Stake® mechanism which ensures full compression every time.

Catalog Number	Terminal Size For use with Spec-Kon®	Std. Pkg	Wt. each
TBM6	8 - 2 AWG	1	9
TBM6S	8 - 2 AWG	1	9

Installing Dies

Nest Stationary Die	Indenter Movable Die	Terminal Size	Gauging (inches)
Installing dies for non-insulated Spec-Kon® terminals			
11805	11802	8 - 6 AWG	.157-.177
11806	11802	4 AWG	.196-.216
11807	11802	2 AWG	.224-.244
Installing dies for insulated Spec-Kon® terminals			
11822	-	8 AWG	.192 - .212
11823	-	6 AWG	.244-.264

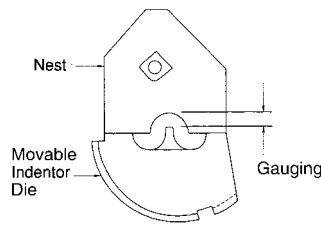

- For use with non-insulated terminals
Cat No. TBM6 and TBM6S

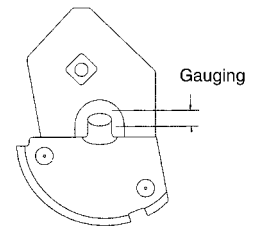

- For use with insulated terminals
Cat No. TBM6 and TBM6S



Spec-Kon®
Automated Tools



Universal Applicator



The Universal Applicator from Thomas & Betts offers a unique opportunity to use the range of quality Spec-Kon tape-mounted terminals on your own machine. If you have the press already, there's no need for additional costly investments on your plant floor to convert to another terminal. Our applicator will handle the entire range of Mylar-tape fed terminals offered in the Spec-Kon product line, and allows you more flexibility on your production line. Fast and simple. If you have the press, we've got the applicator.

Spec-Kon® Universal Applicator includes these prominent features:

- Allows industry-standard presses to use Spec-Kon® Terminal Products (AMP-compatible).
- Includes stand-alone presses.
- Also compatible with major brands of wire processing equipment.
- One single part – no additional accessories needed (excluding dies).
- Quick-change of tooling / dies in minutes – simply done with an Allen wrench.
- Convenient Crimp Height adjustment for range of crimping force fine-tuning.
- 22-10 AWG Range.
- Crimps Insulated and Uninsulated Spec-Kon® terminals.
- Crimps Nylon and Vinyl insulation terminals.
- All-metallic construction for years of use.
- Creates UL Listed Crimps.
- One year warranty, excluding dies.



The new Spec-Kon Universal Applicator is designed for quick terminal conversions in plant equipment such as the Applitek press.

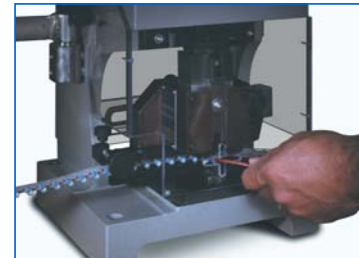

Catalog Number	Description	Std. Pkg	Wt. each
KT2500UA	Spec-Kon® Universal Applicator	1	17 lbs.

AMP is a registered trademark of Tyco Electronics Corporation

Die Chart

Catalog Number	Description	Wire Range
KT-18Z	Insulated Terminals, Disconnects, & Splices	22-16 AWG
KT-14Z	Insulated Terminals, Disconnects, & Splices	16-14 AWG
KT-10Z	Insulated Terminals, Disconnects, & Splices	12-10 AWG
KTU-18Z	Insulated Terminals, Disconnects, & Splices	22-16 AWG
KTU-14Z	Insulated Terminals, Disconnects, & Splices	16-14 AWG
KTU-10Z	Insulated Terminals, Disconnects, & Splices	12-10 AWG

Dimensions: 7.5" x 5.75" x 4.25"

Range: 22 AWG - 10 AWG Insulated and Noninsulated

See instruction manual for complete maintenance, installation and operating characteristics for this tool.

M

Spec-Kon®

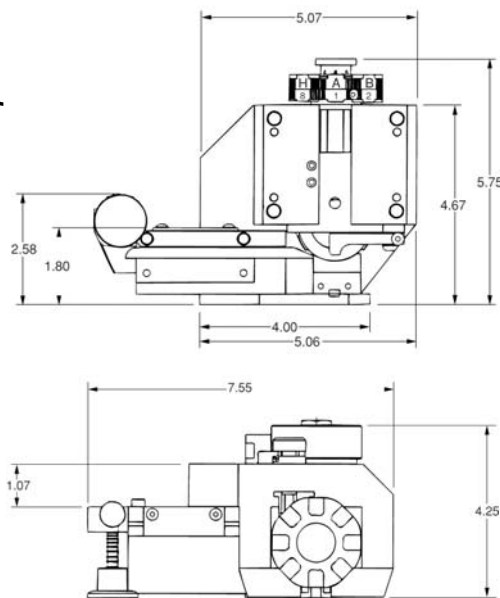

M38

Thomas & Betts

Spec-Kon®
Automated Tools



KT-2500 with reel and foot switch

Bench Mounted Tool for Mylar Tape – KT-2500

Compact, pneumatically operated bench mounted tool for crimping insulated and non-insulated Spec-Kon® terminals on mylar tape. Dies are color coded to match terminal insulation. Unit comes with fully guarded foot pedal and clear plastic safety guard over the die area for added safety. Unit incorporates the Shure-Stake® mechanism which ensures full compression every time.

Catalog Number	Description	Std. Pkg
KT-2500	Bench Mounted Crimping Tool for Mylar Tape	1

Space Requirement: 30”w x 20”h x 20”d
 Weight: 55 lbs.
 Wire Range: 22-10 AWG
 Air Pressure: 90-125 psi input air supply

Installing Dies

Catalog Number	Terminal Style	Wire Range	Gauging (inches)
Installing dies for insulated Spec-Kon® terminals			
KT-18	Insulated Terminals & Disconnects	22-16 AWG	.105 - .109
KT-14	Insulated Terminals & Disconnects	16-14 AWG	.115 - .119
KT-10	Insulated Terminals & Disconnects	12-10 AWG	.134 - .138
Installing dies for non-insulated Spec-Kon® terminals			
KTU-18	Non-Insulated Terminals	22-16 AWG	.072 - .077
KTU-14	Non-Insulated Terminals	16-14 AWG	.096 - .101
KTU-10	Non-Insulated Terminals	12-10 AWG	.126 - .131

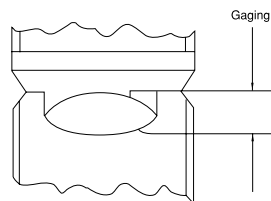

Insulated Terminals

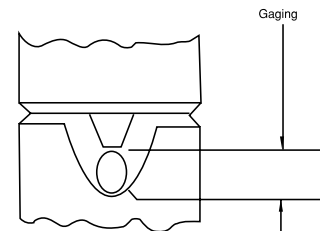

Non-Insulated Terminals

Thomas & Betts

Spec-Kon®

Power Operated Tools



- Start button initiates crimping work cycle.
- Safety catch protects fingers when changing die sets.
- Compact tool head operates in tight spaces and weighs just 1.65 pounds to reduce fatigue.
- Swivel head improves access to small spaces.
- Control lever opens jaws for terminal installation and die change.
- Interchangeable dies accommodate Spec-Kon® terminals from 22-10 AWG.
- Easy-to-see indicator lamps show when ERG 3000 is ready to operate or in a work cycle.
- Portable base power unit houses the battery, hydraulic pump, fluid reservoir, and electronic control unit.
- Durable, flexible 8.2 foot hose connects the tool head to the base power unit for extra reach.

M

Spec-Kon®

ERG3000 Battery Powered Tool

Compact, portable, battery operated tool for crimping loose piece insulated and non-insulated Spec-Kon® terminals. Dies are color coded to match terminal insulation. Multi-nested die used for non-insulated which reduces setup time. Unit incorporates the Shure-Stake® mechanism which ensures full compression every time.

Catalog Number	Description	Wt. (lb.)
Standard Components <i>Note: The part number ERG-3000 refers to a complete kit consisting of one ERG-3001, one ERG-3002, two ERG-3003, one ERG-3004, and one ERG-3005.</i>		
ERG-3001	Base Unit	11.0
ERG-3002	Hose & Tool Head Assembly	3.5
ERG-3003	NiCd Battery	1.3
ERG-3004	15 min. Battery Charge	3.0
ERG-3005	Carrying Case	6.3
ERG-3006	AC Adapter	7.0
ERG-3007	Benchmount	1.0
ERG-3008	Switch	2.5
ERG-3000	Complete Kit (see note below)	26.4

Installing Dies

Catalog Number	Terminal Style	Wire Range	Gauging (inches)
Installing dies for insulated Spec-Kon® terminals			
KT-18Y	Insulated Terminals & Disconnects	22-16 AWG	.105 - .109
KT-14Y	Insulated Terminals & Disconnects	16-14 AWG	.115 - .119
KT-10Y	Insulated Terminals & Disconnects	12-10 AWG	.134 - .138
Installing dies for non-insulated Spec-Kon® terminals			
KTU-2214Y	Non-Insulated Terminals (Two Nested Die Set)	22-16 AWG 16-14 AWG	.072 - .077 .096 - .101
KTU-10Y	Non-Insulated Terminals	12-10 AWG	.126 - .131

Technical Data

Base Unit

Working pressure	3625 psi
Power supply	NiCd Battery 12 V DC or AC/DC converter 110 V 60 Hz
Work cycle	1.5-3 seconds
Weight (with battery)	11 lb. (without tool/hose pack)
Dimensions	13.77"L x 7.28" W x 5.12" D
Temperature range	-4° to 122°F

Tool Head Assembly

Press force	3371 lbf
Weight (tool only)	1.65 lb.
Diameter of handle	1.61 in.
Length of handle	8.86 in.
Length of hose	7.22 ft.

Battery

Type	NiCd 12 V, rechargeable
Recharging time	15 min.
Number of recharges	1000

Thomas & Betts

Spec-Kon®

Power Operated Tools



13500 with foot switch

Bench Mounted Tool – 13500

Compact, pneumatically operated bench mounted tool for crimping loose piece insulated and non-insulated Spec-Kon® terminals. Dies are color coded to match terminal insulation. Multi-nested die used for non-insulated which reduces setup time. Unit incorporates the Shure-Stake® mechanism which ensures full compression every time.

Catalog Number	Description	Std. Pkg
13500	Bench Mounted Crimping Tool	1

Space Requirement: 8" X 12"

Weight: 10-12 lbs.

Wire Range: 8AWG - 2AWG Insulated & Uninsulated Terminals.

Air Pressure: 85-100 psi

Installing Dies

Catalog Number	Terminal Style	Wire Range	Gauging (inches)
Installing dies for insulated Spec-Kon® terminals			
KT-18X KT-14X KT-10X	Insulated Terminals & Disconnects	22-16 AWG 16-14 AWG 12-10 AWG	.105 - .109 .115 - .119 .134 - .138
Installing dies for non-insulated Spec-Kon® terminals			
KTU-2210X*	Non-Insulated Terminals (Three Nested Die Set)	22-16 AWG 16-14 AWG 12-10 AWG	.072 - .077 .096 - .101 .126 - .131

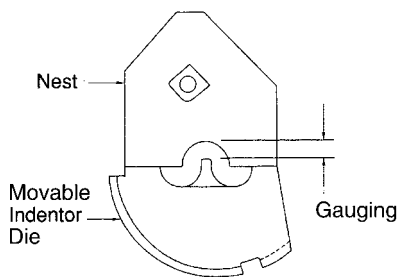

- For use with non-insulated terminals
Cat No. TBM6 and TBM6S

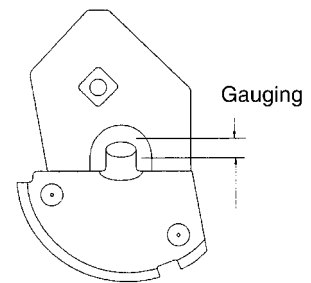

- For use with insulated terminals
Cat No. TBM6 and TBM6S



Spec-Kon®

Application Information

Tool and Die Selection Chart

Spec-Kon® Terminals		Plier Tool	Ergonomic Hand Tool	KT-2500 Pneumatic Tool Die Part Numbers			13500 Pneumatic Tool Die Part Numbers			Erg-3000 Power Hand Tool Die Part Numbers		
Nylon Terminal (22-10 AWG)	KN or KNF	WT112M	ERG-2500	KT-18	KT-14	KT-10	KT-18X	KT-14X	KT-10X	KT-18Y	KT-14Y	KT-10Y
Nylon Butt Splice		WT112M	ERG-2500	N/A	N/A	N/A	KT-18X	KT-14X	KT-10X	KT-18Y	KT-14Y	KT-10Y
Nylon Disconnect		WT112M	ERG-2500	KT-18	KT-14	KT-10	KT-18X	KT-14X	KT-10X	KT-18Y	KT-14Y	KT-10Y
Nylon Terminal (8-6 AWG)		TBM6	N/A	KT-8	KT-6	N/A	N/A	N/A	N/A	N/A	N/A	N/A
Vinyl Terminal (22-10 AWG)	KV or KVF	WT112M	ERG-2500	KT-18	KT-14	KT-10	KT-18X	KT-14X	KT-10X	KT-18Y	KT-14Y	KT-10Y
Vinyl Butt Splice		WT112M	ERG-2500	KT-18	KT-14	KT-10	KT-18X	KT-14X	KT-10X	KT-18Y	KT-14Y	KT-10Y
Vinyl Disconnect		WT112M	ERG-2500	KT-18	KT-14	KT-10	KT-18X	KT-14X	KT-10X	KT-18Y	KT-14Y	KT-10Y
Non Insulated Terminal (22-10 AWG)	K	WT111M	ERG-2002	KTU-18	KTU-14	KTU-10	KTU-2210X	KTU-2210X	KTU-2210X	KTU-2214Y KTU-10Y	KTU-2214Y KTU-10Y	KTU-2214Y KTU-10Y
Non Insulated Butt Splice		WT111M	ERG-2002	N/A	N/A	N/A	KTU-2210X	KTU-2210X	KTU-2210X	KTU-2214Y KTU-10Y	KTU-2214Y KTU-10Y	KTU-2214Y KTU-10Y
Non Insulated Terminal (8-6 AWG)		TBM6	N/A	N/A	N/A	N/A	KTU-8	KTU-6	N/A	N/A	N/A	N/A
Wire Joints	KN or KNF	WT112M	ERG-2500WJ	N/A	N/A	N/A	N/A	N/A	N/A	N/A	N/A	N/A
Flag Terminals	KN or KNF	N/A	ERG-2500F	N/A	N/A	N/A	N/A	N/A	N/A	N/A	N/A	N/A

Strip Length Chart













Description	Terminal Series	Wire Strip Length
Non-Insulated Terminals	K18	1/4"
	K14	1/4"
	K10	5/16"
	K8	3/8"
	K6	7/16"
	K4	1/2"
	K2	9/16"
Vinyl Insulated Terminals	KV18	1/4"
	KV14	1/4"
	KV10	5/16"
	KV8	3/8"
	KV6	7/16"
Nylon Insulated Terminals	KN18	1/4"
	KN14	1/4"
	KN10	5/16"
	KN8	3/8"
	KN6	7/16"
Vinyl Insulated Disconnects	KV18	1/4"
	KV14	1/4"
	KV10	5/16"
Nylon Insulated Disconnects	KN18	1/4"
	KN14	1/4"
	KN10	5/16"
Vinyl Insulated Butt Splices	KV18	5/16"
	KV14	5/16"
	KV10	5/16"
Nylon Insulated Butt Splices	KN18	1/4"
	KN14	1/4"
	KN10	1/4"
Nylon Wire Joints	K18	9/32"
	K14	9/32"
	K10	11/32"

Thomas & Betts

Spec-Kon®

Application Information

Stud Size Chart

Standard Stud Size U.S		Stud Diameter Inches mm	Terminal Hole Dia. Inches mm	Spec-Kon® Stud Size Part No. Designation
	#2 M2	.086 2.18	.090 2.29	2
	#4 M2,5	.112 2.84	.118 3.00	4
	#5 M3	.125 3.18	.127 3.23	5
	#6 M3,5	.138 3.51	.146 3.71	6
	#8 M4	.164 4.17	.173 4.39	8
	#10 M5	.190 4.83	.198 5.03	10
	1/4 M6	.250 6.35	.270 6.86	14
	5/16 M8	.312 7.92	.330 8.38	56
	3/8 M10	.375 9.53	.385 9.78	38
	1/2 M12	.500 12.7	.520 13.21	12
	5/8 M16	.625 15.88	.650 16.51	58
	3/4 M18	.750 19.05	.810 20.57	34

Common Conductor Size Chart

Size	No. of Strands	Individual Strand Size	Conductor Size	
		Inches mm	Inches mm	Circl. Mil Area mm
22AWG	7	.0096 0.24	.028 0.74	640 0.74
20AWG	10	.0100 0.25	.038 0.97	1020 0.519
18AWG	16	.0100 0.25	.048 1.22	1620 0.823
16AWG	26	.0100 0.25	.060 1.52	2580 1.310
14AWG	7	.0242 0.61	.073 1.85	4110 2.080
12AWG	7	.0305 0.77	.092 2.34	6530 3.310
10AWG	7	.0385 0.98	.116 2.95	10,380 5.261
8AWG	7	.0486 1.23	.146 3.71	16,510 8.367
6AWG	7	.0612 1.55	.184 4.67	26,240 13.30
4AWG	7	.0772 1.96	.232 5.89	41,740 21.15
2AWG	7	.0974 2.47	.292 7.42	66,360 33.62
1AWG	19	.0664 1.69	.332 8.43	83,690 42.41
1/10AWG	19	.0745 1.89	.373 9.47	105,600 53.49
2/0AWG	19	.0837 2.13	.418 10.62	133,100 67.43
3/0AWG	19	.0940 2.39	.470 11.94	167,800 85.01
4/0AWG	19	.1055 2.68	.528 13.41	211,600 107.2
250MCM	37	.0822 2.09	.575 14.61	250,000 127
300MCM	37	.0900 2.29	.630 16.00	300,000 152
350MCM	37	.0973 2.47	.681 17.29	350,000 177
400MCM	37	.1040 2.64	.728 18.49	400,000 203
500MCM	37	.1162 2.95	.813 20.65	500,000 253
600MCM	61	.0992 2.52	.893 22.68	600,000 304
750MCM	61	.1109 2.82	.998 25.35	750,000 380
800MCM	61	.1145 2.91	1.031 26.19	800,000 405
1000MCM	61	.1280 3.25	1.152 29.26	1,000,000 507



X-ON Electronics

Largest Supplier of Electrical and Electronic Components

Click to view similar products for [Terminals](#) category:

Click to view products by [ABB](#) manufacturer:

Other Similar products are found below :

[HT-13-10](#) [71M-250-32-NB](#) [01-2065-1-0216](#) [00581P0075](#) [M10-10RX](#) [M10BCK](#) [60205-1](#) [604200-1](#) [60598-1-CUT-TAPE](#) [60617-1-C](#) [60873-1](#) [M14-516R/SK](#) [M14-6RSX](#) [M18-10FLX](#) [M18-8FBX](#) [M18-8R/LX](#) [M18BCK](#) [61314-6-C](#) [61-S](#) [61-SN-A](#) [62-NBM-A](#) [63-S](#) [640179-1](#) [640917-2-CUT-TAPE](#) [6501550002](#) [66107-2-C](#) [66107-4-C](#) [696683-1](#) [696834-1](#) [696861-1](#) [696931-1](#) [696999-1](#) [M8-516RK](#) [M86700006](#) [MA250DMFMX-A](#) [701-2007](#) [701-2307](#) [701-7761-03](#) [70F-110-32-PB](#) [718-N-A](#) [71M-187-20-NBL](#) [71M-250-32-NBL](#) [72F-187-20-NBL](#) [72M-250-32-NBL](#) [7310](#) [73F-250-32](#) [73F-250-32-NBL](#) [73F-250-32-NL](#) [F14-10C](#) [F-1M](#)