



## RVT43ULSNWC0x

### LCD TFT Datasheet

Rev.1.1

2015-03-31

ITEM	CONTENTS	UNIT
LCD Type	TFT/Transmissive/Normally white	/
Size	4.3	Inch
Viewing Direction	12:00 (without image inversion)	O' Clock
Gray Scale Inversion Direction	6:00	O' Clock
LCM (W × H × D )	120.38 × 79.20 × 8.43	mm <sup>3</sup>
Active Area (W × H)	95.04 × 53.86	mm <sup>2</sup>
Dot Pitch (W × H)	0.066×0.198	mm <sup>2</sup>
Number Of Dots	480 x (RGB) × 272	/
Driver IC	SSD1963	/
Backlight Type	10 LEDs	/
Surface Luminance	500	cd/m <sup>2</sup>
Interface Type	Parallel 8/16b (i80 by default)	/
Color Depth	262k	/
Pixel Arrangement	RGB Vertical Stripe	/
Surface Treatment	Clear	
Input Voltage	3.3	V
With/Without TSP	Projected Capacitive Touch Panel	/
Weight	79.14	g

**Note 1:** RoHS compliant

**Note 2:** LCM weight tolerance: ± 5%.



## REVISION RECORD

REVNO.	REVDATE	CONTENTS	REMARKS
1.0	2015-02-19	Initial Release	
1.1	2015-03-31	Surface Treatment data correction	

## CONTENTS

REVISION RECORD.....	2
CONTENTS .....	2
1 MODULE CLASSIFICATION INFORMATION .....	3
2 MODULE DRAWING .....	4
3 ABSOLUTE MAXIMUM RATINGS.....	5
4 ELECTRICAL CHARACTERISTICS.....	5
5 ELECTRO-OPTICAL CHARACTERISTICS .....	5
6 INTERFACE DESCRIPTION .....	7
7 INTERFACE TIMING CHARACTERISTICS.....	8
7.1 8080 Mode .....	8
7.2 Pixel Data Format .....	8
7.3 Parallel 8080-series Interface Timing .....	9
8 LCD TIMING CHARACTERISTICS .....	10
8.1 Clock and data input time diagram .....	10
8.2 Parallel RGB input timing table .....	10
9 CAPACITIVE TOUCH SCREEN PANEL SPECIFICATIONS .....	11
9.1 Mechanical characteristics .....	11
9.2 Electrical characteristics .....	11
9.3 Interface timing characteristics.....	11
9.4 I2C Read/Write Interface Description .....	11
9.5 Communication of the I <sup>2</sup> C interface with Host .....	12
9.6 Touch data read protocol.....	12
9.7 Data description .....	13
10 ORDERING INFORMATION .....	15
11 CUSTOMIZATION LEVEL.....	16
12 RELIABILITY TEST .....	16
13 LEGAL INFORMATION .....	17

## 1 MODULE CLASSIFICATION INFORMATION

<b>RV</b>	<b>T</b>	<b>43</b>	<b>U</b>	<b>L</b>	<b>S</b>	<b>N</b>	<b>W</b>	<b>C</b>	<b>0x</b>
1.	2.	3.	4.	5.	6.	7.	8.	9.	10.

1.	<b>BRAND</b>	<b>RV – Riverdi</b>
2.	<b>PRODUCT TYPE</b>	<b>T – TFT Standard</b> F – TFT Custom
3.	<b>DISPLAY SIZE</b>	<b>35 – 3.5”</b> <b>43 – 4.3”</b> <b>57 – 5.7”</b> <b>70 – 7.0”</b>
4.	<b>MODEL SERIAL NO.</b>	<b>U (A-Z)</b>
5.	<b>RESOLUTION</b>	<b>L – 480x272 px</b>
6.	<b>INTERFACE</b>	T – TFT LCD, RGB L – TFT LCD, LVDS <b>S – TFT + Controller SSD1963</b> F – TFT + Controller FT801
7.	<b>FRAME</b>	<b>N – No Frame</b> F – Mounting Frame
8.	<b>BACKLIGHT TYPE</b>	<b>W – LED White</b>
9.	<b>TOUCH PANEL</b>	<b>C – Capacitive Touch Panel</b>
10.	<b>VERSION</b>	<b>0x (00, 01, 02, 03, 04, 05)</b>

# LCD TFT Datasheet Rev.1.1

## RVT43ULSNWC0x

PIN	DESC
1	GND
2	VDD
3	BL_E
4	D/C
5	WR
6	RD
7	D0
8	D1
9	D2
10	D3
11	D4
12	D5
13	D6
14	D7
15	D8
16	D9
17	D10
18	D11
19	D12
20	D13
21	D14
22	D15
23	NC
24	TP_INT
25	CS
26	RESET
27	DISP ON
28	NC
29	TP_SCL
30	TP_SDA
31	TP_RST
32	TP_WAKE
33	VLED-
34	VLED-
35	VLED+
36	VLED+

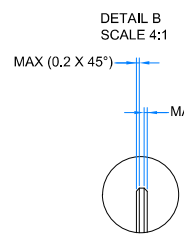
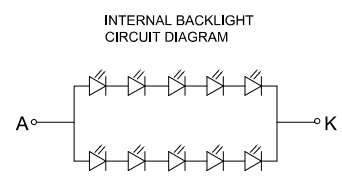
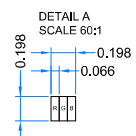
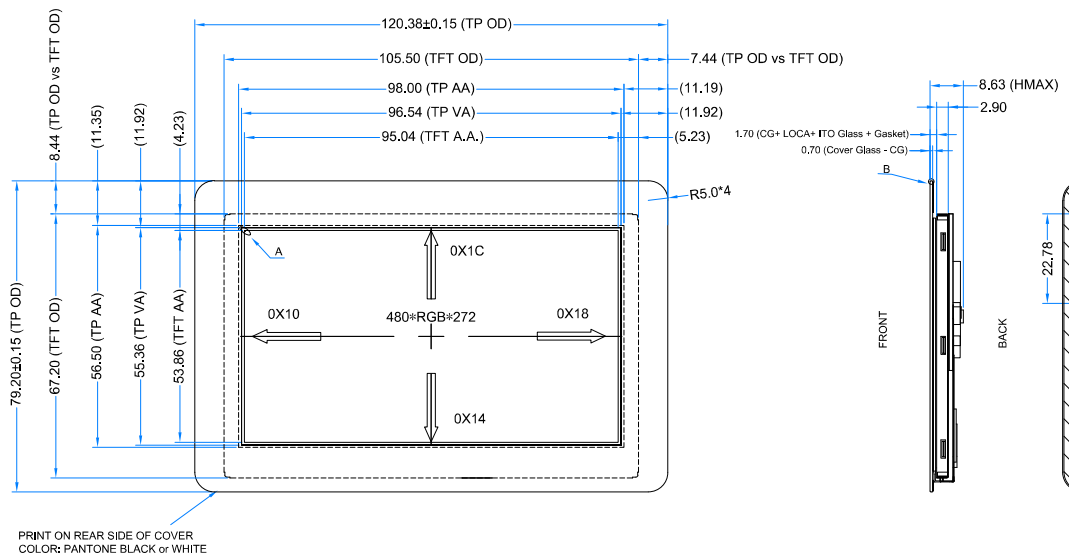

- NOTES:
1. DISPLAY TYPE: TFT, TRANSMISSIVE, NORMALLY WHITE
  2. 4.3 INCH PROJECTIVE CAPACITIVE TOUCH PANEL.
  3. OPERATION VOLTAGE: VDD=3.3V
  4. VIEWING DIRECTION: 12 O'CLOCK
  5. IC CONTROLLER: SSD1963QL9
  6. CTP RESOLUTION: 1280 X 768 DOTS
  7. CTP IC DRIVER: FT5306 (SMT)
  8. CTP MULTI FINGER: UP TO 5
  9. OPERATING TEMP.: -20°C ~ 70°C
  10. STORAGE TEMP.: -30°C ~ 80°C
  11. LED BACKLIGHT: 10-LED WHITE, BUILT-IN INVERTER
  12. SURFACE LUMINANCE: 500cd/m<sup>2</sup>
  13. GENERAL TOLERANCE: ±0.2
  14. RoHS COMPLIANT

Ver.	DESCRIPTION	DATE
1.0	Initial case	2015.08.26

### 3 ABSOLUTE MAXIMUM RATINGS

PARAMETER	SYMBOL	MIN	MAX	UNIT
Supply Voltage For Logic	VDD	-0.3	3.6	V
Input Voltage For Logic	VIN	-0.3	VDD	V
Input Voltage For LED Inverter	BLVDD	-0.3	7.0	V
Operating Temperature	T <sub>OP</sub>	-20	70	°C
Storage Temperature	T <sub>ST</sub>	-30	80	°C
Humidity	RH	-	90% (Max 60°C)	RH

### 4 ELECTRICAL CHARACTERISTICS

PARAMETER	SYMBOL	MIN	TYP	MAX	UNIT	NOTES
Supply Voltage For Module	VDD	3.0	3.3	3.6	V	
Input Voltage for LED Inverter	BLVDD	2.8	3.3	5.5	V	
Input Voltage 'H' level for BL_E pin	BL_EH	1.5	-	5.5	V	
Input Voltage 'L' level for BL_E pin	BL_EL	0	-	0.7	V	
Input Current (Exclude LED Backlight)	IDD	-	31	39	mA	VDD = 3.3V
LED Backlight Current	IDD <sub>backlight</sub>		265	332	mA	BLVDD=3.3V
LED Backlight Current	IDD <sub>backlight</sub>		156	195	mA	BLVDD=5V
Total Input Current (Include LED Backlight 100%)	IDD <sub>total</sub>	-	296	371	mA	BLVDD=3.3V
Input Voltage 'H' level	V <sub>IH</sub>	0.7VDD	-	VDD	V	
Input Voltage 'L' level	V <sub>IL</sub>	0	-	0.2VDD	V	
LED Life Time	-	30000	50000	-	Hrs	Note 1

**Note 1:** The LED life time is defined as the module brightness decrease to 50% original brightness at Ta=25°C.

### 5 ELECTRO-OPTICAL CHARACTERISTICS

ITEM	SYMBOL	CONDITION	MIN	TYP	MAX	UNIT	REMARK	NOTE
Response Time	Tr+Tf	θ=0° ∅=0° Ta=25	-	25	30	ms	Figure 1	4
Contrast Ratio	Cr		400	500	-	---	Figure 2	1
Luminance Uniformity	δ WHITE		80	-	-	%	Figure 2	3
Surface Luminance	Lv		-	500	-	cd/m <sup>2</sup>	Figure 2	2
Viewing Angle Range	θ	∅ = 90°	40	50	-	deg	Figure 3	6
		∅ = 270°	60	70	-	deg	Figure 3	
		∅ = 0°	60	70	-	deg	Figure 3	
		∅ = 180°	60	70	-	deg	Figure 3	
CIE (x, y) Chromaticity	Red	θ=0° ∅=0° Ta=25	x	0.551	0.591	0.631	Figure 2	5
			y	0.270	0.310	0.350		
	Green		x	0.302	0.342	0.382		
			y	0.516	0.561	0.601		
	Blue		x	0.105	0.145	0.185		
			y	0.047	0.087	0.127		
	White		x	0.250	0.290	0.330		
			y	0.300	0.340	0.380		

**Note 1.** Contrast Ratio(CR) is defined mathematically as below, for more information see Figure 1.

$$\text{Contrast Ratio} = \frac{\text{Average Surface Luminance with all white pixels (P1, P2, P3, P4, P5)}}{\text{Average Surface Luminance with all black pixels (P1, P2, P3, P4, P5)}}$$

**Note 2.** Surface luminance is the LCD surface from the surface with all pixels displaying white. For more information see Figure 2.

$L_v$  = Average Surface Luminance with all white pixels (P1, P2, P3, P4, P5)

**Note 3.** The uniformity in surface luminance  $\delta$  WHITE is determined by measuring luminance at each test position 1 through 5, and then dividing the maximum luminance of 5 points luminance by minimum luminance of 5 points luminance. For more information see Figure 2.

$$\delta \text{ WHITE} = \frac{\text{Minimum Surface Luminance with all white pixels (P1, P2, P3, P4, P5)}}{\text{Maximum Surface Luminance with all white pixels (P1, P2, P3, P4, P5)}}$$

**Note 4.** Response time is the time required for the display to transition from white to black (Rise Time,  $T_r$ ) and from black to white (Decay Time,  $T_f$ ). For additional information see FIG 1. The test equipment is Autronic-Melchers's ConoScope series.

**Note 5.** CIE (x, y) chromaticity, the x, y value is determined by measuring luminance at each test position 1 through 5, and then make average value.

**Note 6.** Viewing angle is the angle at which the contrast ratio is greater than 2. For TFT module the contrast ratio is greater than 10. The angles are determined for the horizontal or x axis and the vertical or y axis with respect to the z axis which is normal to the LCD surface. For more information see Figure 3.

**Note 7.** For viewing angle and response time testing, the testing data is based on Autronic-Melchers's ConoScope series. Instruments for Contrast Ratio, Surface Luminance, Luminance Uniformity, CIE the test data is based on TOPCON's BM-5 photo detector.

Figure 1. The definition of response time



Figure 2. Measuring method for Contrast ratio, surface luminance, Luminance uniformity, CIE (x,y) chromaticity

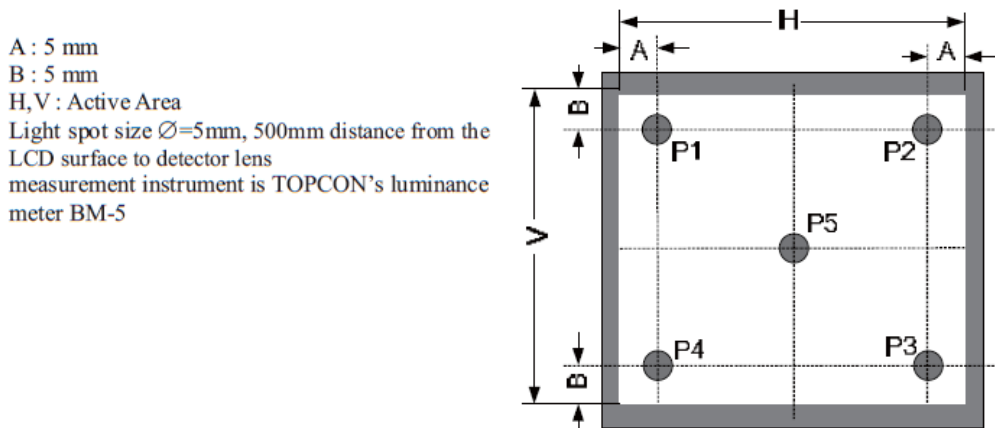
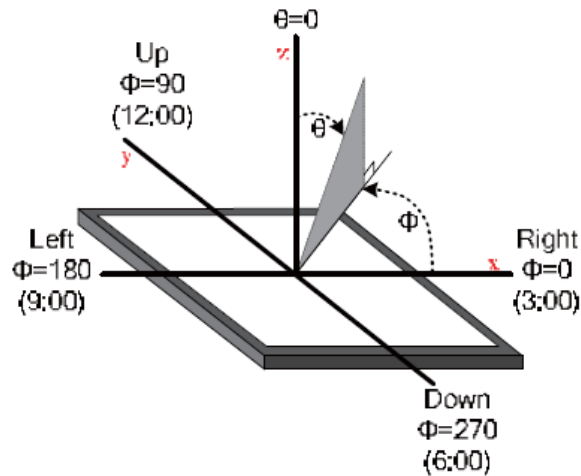

Figure 3. The definition of viewing angle



## 6 INTERFACE DESCRIPTION

PIN NO.	SYMBOL	I/O	DESCRIPTION
1	GND	P	Power Ground
2	VDD	P	Power Supply: +3.3V
3	BL_E	I	Backlight Control Signal, H: On/L: Off (internally pulled-up to BLVDD)
4	D/C	I	Data/Command Select
5	WR	I	Write Strobe Signal
6	RD	I	Read Strobe Signal
7-22	D0-D15	I	Data Bus. Pins not used should be floating.
23	NC	-	No Connection
24	TP_INT	-	Touch Panel INT
25	CS	I	Chip Select
26	RESET	I	Hardware reset
27	DISP ON	I	Display Control H: On/L: Off (internally pulled-up)
28	NC	-	No Connection
29	TP_SCL	-	Touch Panel I2C SCL Signal

<b>30</b>	TP_SDA	-	Touch Panel I2C SDA Signal
<b>31</b>	TP_RST	-	Touch Panel RST Signal, Active Low
<b>32</b>	TP_WAKE	-	Touch Panel Wake Signal, Active Low
<b>33</b>	BLGND	-	Backlight ground, can be connected to GND
<b>34</b>	BLGND	-	Backlight ground, can be connected to GND
<b>35</b>	BLVDD	-	Backlight power supply, can be connected to VDD
<b>36</b>	BLVDD	-	Backlight power supply, can be connected to VDD

## 7 INTERFACE TIMING CHARACTERISTICS

### 7.1 8080 Mode

The 8080 mode MCU interface consist of CS#, D/C#, RD#, WR#, D[15:0]. This interface use WR# to define a write cycle and RD# for read cycle. If the WR# goes low when the CS# signal is low, the data or command will be latched into the system at the rising edge of WR#. Similarly, the read cycle will start when RD# goes low and end at the rising edge of RD#.

### 7.2 Pixel Data Format

Interface	Cycle	D[17]	D[16]	D[15]	D[14]	D[13]	D[12]	D[11]	D[10]	D[9]	D[8]	D[7]	D[6]	D[5]	D[4]	D[3]	D[2]	D[1]	D[0]
16 bits (565 format)	1 <sup>st</sup>			R5	R4	R3	R2	R1	G5	G4	G3	G2	G1	G0	B5	B4	B3	B2	B1
16 bits	1 <sup>st</sup>			R7	R6	R5	R4	R3	R2	R1	R0	G7	G6	G5	G4	G3	G2	G1	G0
	2 <sup>nd</sup>			B7	B6	B5	B4	B3	B2	B1	B0	R7	R6	R5	R4	R3	R2	R1	R0
	3 <sup>rd</sup>			G7	G6	G5	G4	G3	G2	G1	G0	B7	B6	B5	B4	B3	B2	B1	B0
12 bits	1 <sup>st</sup>							R7	R6	R5	R4	R3	R2	R1	R0	G7	G6	G5	G4
	2 <sup>nd</sup>							G3	G2	G1	G0	B7	B6	B5	B4	B3	B2	B1	B0
9 bits	1 <sup>st</sup>										R5	R4	R3	R2	R1	R0	G5	G4	G3
	2 <sup>nd</sup>									G2	G1	G0	B5	B4	B3	B2	B1	B0	
8 bits	1 <sup>st</sup>											R7	R6	R5	R4	R3	R2	R1	R0
	2 <sup>nd</sup>											G7	G6	G5	G4	G3	G2	G1	G0
	3 <sup>rd</sup>											B7	B6	B5	B4	B3	B2	B1	B0



7.3 Parallel 8080-series Interface Timing

Figure 4. Parallel 8080-series Interface Timing Diagram (Write Cycle)

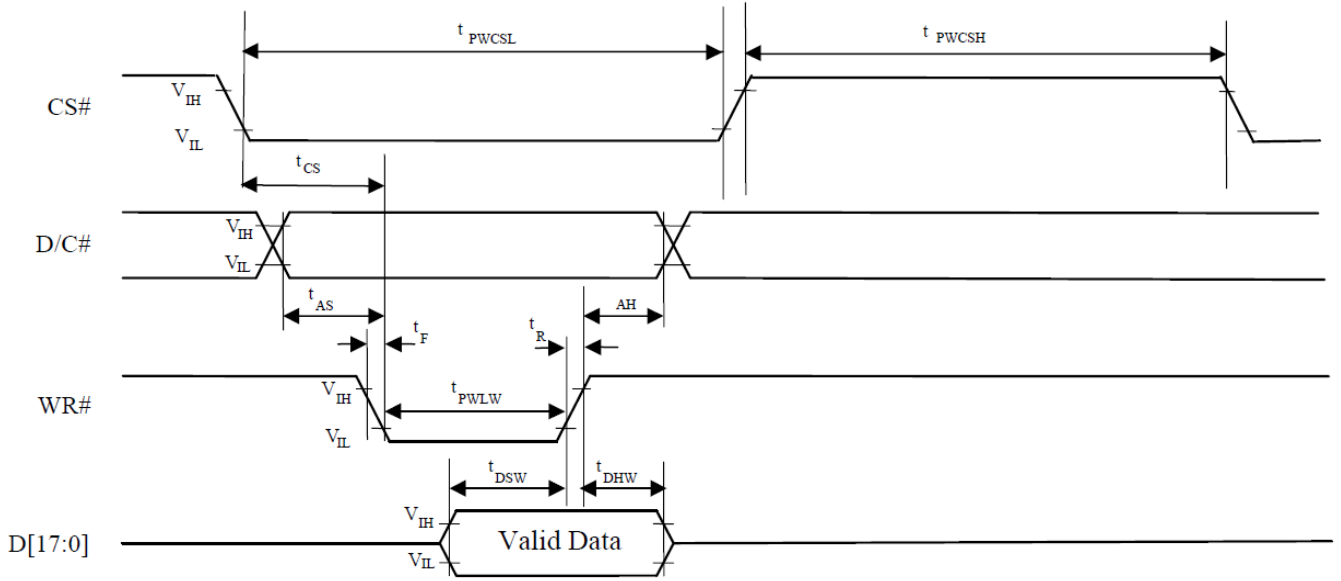
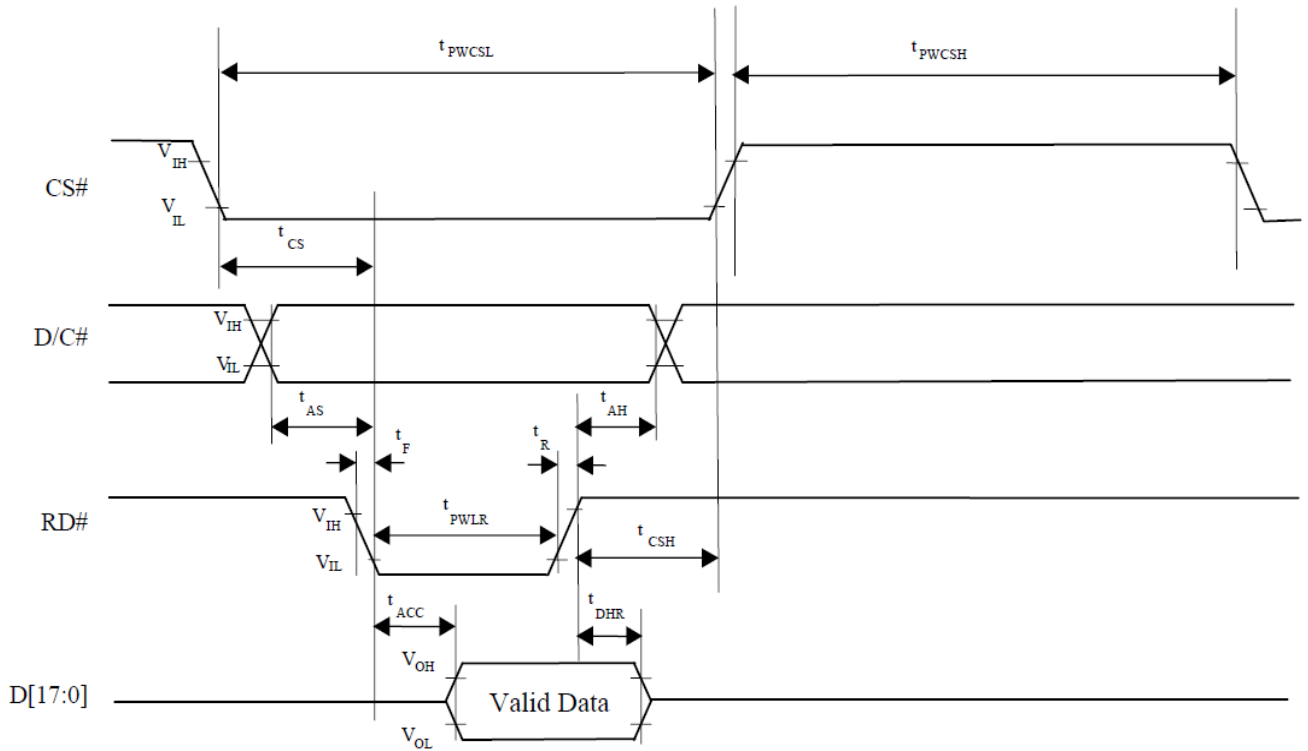

Figure 5. Parallel 8080-series Interface Timing Diagram (Read Cycle)



## 8 LCD TIMING CHARACTERISTICS

### 8.1 Clock and data input time diagram

Figure 6. Clock and data input time diagram

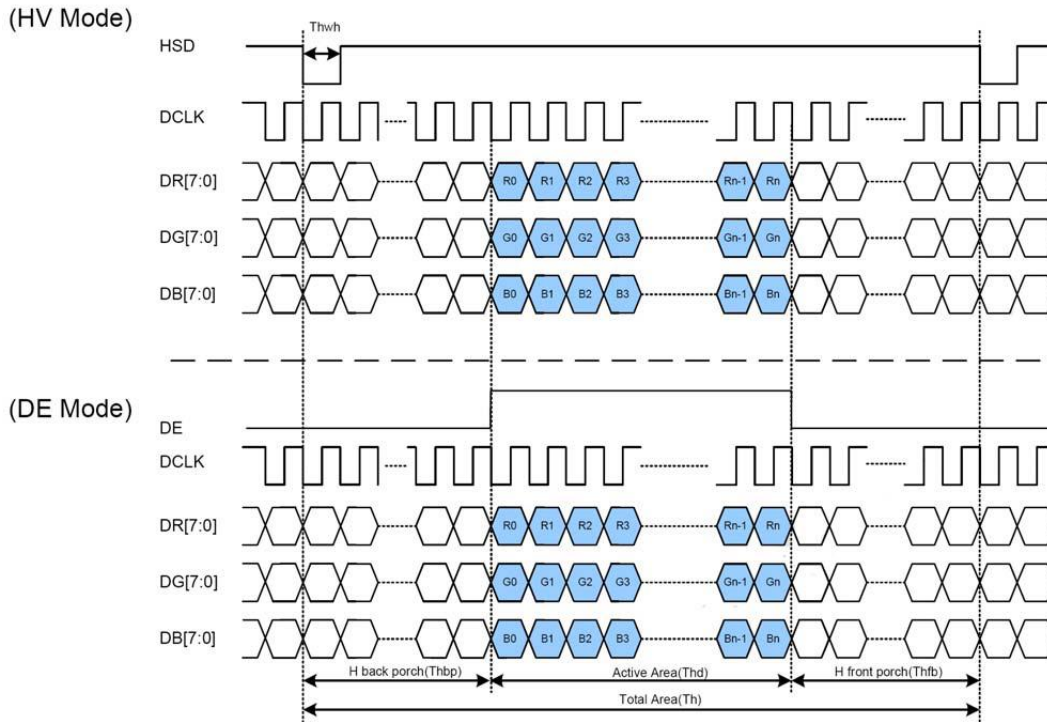

### 8.2 Parallel RGB input timing table

PARAMETER	SYMBOL	MIN	TYP	MAX	UNIT
DCLK Frequency	Fclk	5	9	12	MZH
VSD Period Time	Tv	277	288	400	H
VSD Display Area	Tvd		272		H
VSD Back Porch	Tvb	3	8	31	H
VSD Front Porch	Tvfp	2	8	97	H
HSD Period Time	Th	520	525	800	DCLK
HSD Display Area	Thd		480		DCLK
HSD Back Porch	Thbp	36	40	255	DCLK
HSD Front Porch	Thfp	4	5	65	DCLK

## 9 CAPACITIVE TOUCH SCREEN PANEL SPECIFICATIONS

### 9.1 Mechanical characteristics

DESCRIPTION	INL SPECIFICATION	REMARK
Touch Panel Size	4.3 inch	
Outline Dimension (OD)	120.38mm x 79.20mm	Cover Lens Outline
Product Thickness	1.70mm	
Glass Thickness	0.70mm	
Ink View Area	96.54mm x 55.36mm	
Sensor Active Area	98.00mm x 56.50mm	
Input Method	5 Finger	
Activation Force	Touch	
Surface Hardness	≥7H	

### 9.2 Electrical characteristics

DESCRIPTION	SPECIFICATION
Operating Voltage	DC 2.8~3.3V
Power Consumption (IDD)	Active Mode
	Sleep Mode
Interface	I <sup>2</sup> C
Linearity	<1.5%
Controller	FT5306
I2C address	0x38 (7 bit address)
Resolution	1280*768

### 9.3 Interface timing characteristics

PARAMETER	MIN	MAX	UNIT
SCL Frequency	0	400	kHz
Bus Free Time Between a STOP and START Condition	4.7	/	μs
Hold Time (repeated) START Condition	4.0	/	μs
Data Setup Time	250	/	ns
Setup Time for Repeated START Condition	4.7	/	μs
Setup Time for STOP Condition	4.0	/	μs

### 9.4 I2C Read/Write Interface Description

Figure 7. Write N bytes to I2C slave

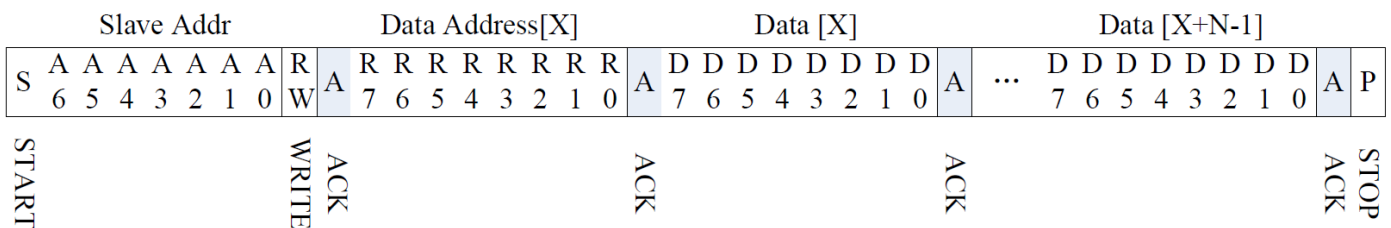

Figure 8. Set Data Address

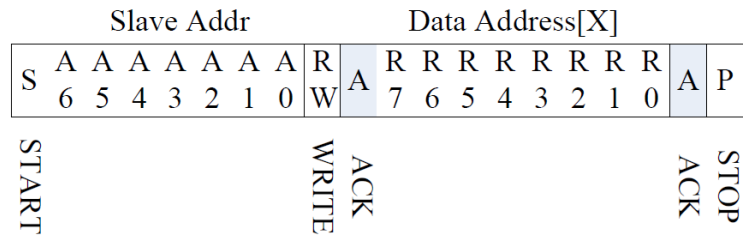
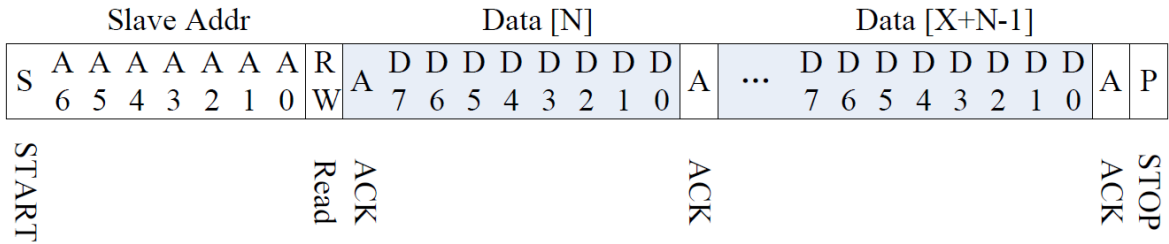
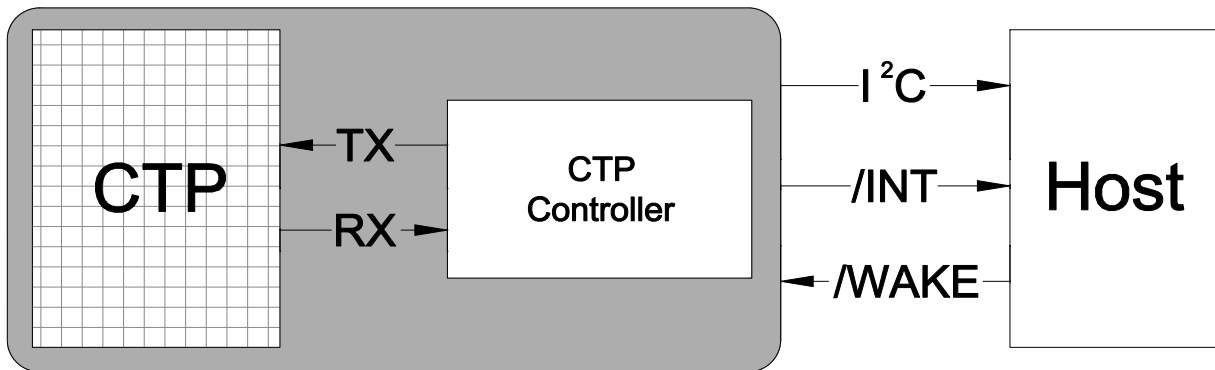

Figure 9. Read X bytes from I2C Slave



### 9.5 Communication of the I<sup>2</sup>C interface with Host

Figure 10. Communication of the I2C interface with Host



### 9.6 Touch data read protocol

ADDRESS	NAME	BIT	BIT	BIT	BIT	BIT	BIT	BIT	BIT	HOST ACCESS
		7	6	5	4	3	2	1	0	
00h	DEVIDE_MODE	Device Mode[2:0]								RW
01h	GEST_ID	Gesture ID[7:0]								R
02h	TD_STATUS					Number of touch points[3:0]				R
03h	TOUCH1_XH	1 <sup>st</sup> Event Flag				1 <sup>st</sup> Touch X Position[11:8]				R
04h	TOUCH1_XL	1 <sup>st</sup> Touch X Position[7:0]								R
05h	TOUCH1_YH	1 <sup>st</sup> Touch ID[3:0]				1 <sup>st</sup> Touch X Position[11:8]				R
06h	TOUCH1_YL	1 <sup>st</sup> Touch Y Position[7:0]								R
07h										R
08h										R

09h	TOUCH2_XH	2 <sup>nd</sup> Event Flag			2 <sup>nd</sup> Touch X Position[11:8]	R
0Ah	TOUCH2_XL	2 <sup>nd</sup> Touch X Position[7:0]				R
0Bh	TOUCH2_YH	2 <sup>nd</sup> Touch ID[3:0]			2 <sup>nd</sup> Touch X Position[11:8]	R
0Ch	TOUCH2_YL	2 <sup>nd</sup> Touch Y Position[7:0]				R
0Dh						R
0Eh						R
0Fh	TOUCH3_XH	3 <sup>rd</sup> Event Flag			3 <sup>rd</sup> Touch X Position[11:8]	R
10h	TOUCH3_XL	3 <sup>rd</sup> Touch X Position[7:0]				R
11h	TOUCH3_YH	3 <sup>rd</sup> Touch ID[3:0]			3 <sup>rd</sup> Touch X Position[11:8]	R
12h	TOUCH3_YL	3 <sup>rd</sup> Touch Y Position[7:0]				R
13h						R
14h						R
15h	TOUCH4_XH	4 <sup>th</sup> Event Flag			4 <sup>th</sup> Touch X Position[11:8]	R
16h	TOUCH4_XL	4 <sup>th</sup> Touch X Position[7:0]				R
17h	TOUCH4_YH	4 <sup>th</sup> Touch ID[3:0]			4 <sup>th</sup> Touch X Position[11:8]	R
18h	TOUCH4_YL	4 <sup>th</sup> Touch Y Position[7:0]				R
19h						R
1Ah						R
1Bh	TOUCH5_XH	5 <sup>th</sup> Event Flag			5 <sup>th</sup> Touch X Position[11:8]	R
1Ch	TOUCH5_XL	5 <sup>th</sup> Touch X Position[7:0]				R
1Dh	TOUCH5_YH	5 <sup>th</sup> Touch ID[3:0]			5 <sup>th</sup> Touch X Position[11:8]	R
1Eh	TOUCH5_YL	5 <sup>th</sup> Touch Y Position[7:0]				R

## 9.7 Data description

### DEVICE\_MODE

This register is the device mode register, configure it to determine the current mode of the chip.

ADDRESS	BIT ADDRESS	REGISTER NAME	DESCRIPTION
00h	6:4	Device Mode [2:0]	000b Work Mode 100b Factory Mode – Read Raw Data

### GEST\_ID

This register describes the gesture of a valid touch.

ADDRESS	BIT ADDRESS	REGISTER NAME	DESCRIPTION
01h	7:0	Gesture ID [7:0]	Gesture ID 0x10 Move Up 0x14 Move Down 0x18 Move Right 0x48 Zoom In 0x49 Zoom Out 0x00 No Gesture

### TD\_STATUS

This register is the Touch Data status register.

ADDRESS	BIT ADDRESS	REGISTER NAME	DESCRIPTION
02h	3:0	Number of Touch Points [2:0]	How Many Points Detected 1-5 is Valid
	7:4		

**TOUCHn\_XH(n:1-10)**

This register describes MSB of the X coordinate of the nth touch point and the corresponding event flag.

ADDRESS	BIT ADDRESS	REGISTER NAME	DESCRIPTION
03h ~ 39h	7:6	Event Flag	00b: Put Down
			01b: Put Up
	5:4		Reserved
	3:0	Touch X Position [11:8]	MSB of Touch X Position in Pixels

**TOUCHn\_XL(n:1-10)**

This register describes LSB of the X coordinate of the nth touch point.

ADDRESS	BIT ADDRESS	REGISTER NAME	DESCRIPTION
04h ~ 3Ah	7:0	Touch X Position [7:0]	LSB of the Touch X Position in Pixels

**TOUCHn\_YH(n:1-10)**

This register describes MSB of the Y coordinate of the nth touch point and corresponding touch ID.

ADDRESS	BIT ADDRESS	REGISTER NAME	DESCRIPTION
05h ~ 3Bh	7:4	Touch ID[3:0]	Touch ID of Touch Point
	3:0	Touch X Position [11:8]	MSB of Touch Y Position in Pixels

**TOUCHn\_YL(n:1-10)**

This register describes LSB of the Y coordinate of the nth touch point.

ADDRESS	BIT ADDRESS	REGISTER NAME	DESCRIPTION
05h ~ 3Bh	7:0	Touch X Position [7:0]	LSB of the Touch Y Position in Pixels

## 10 ORDERING INFORMATION

Three options of rear side adhesive tape are available: double side adhesive tape 0.2 mm with 3M 467MP glue, foam double side adhesive tape 0.5 mm with 3M 467MP glue or without any tape. There are also two versions of glass color: black and white.

Rear side adhesive tape options:

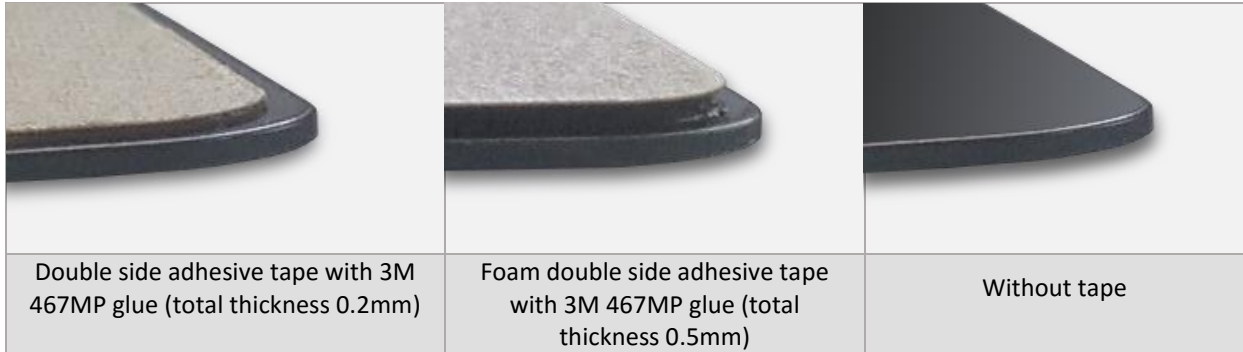

Cover glass color options:



Product options:

PN	DESCRIPTION
RVT43ULSNWC00	<ul style="list-style-type: none"> <li>• Double side adhesive tape with 3M 467MP glue (total thickness 0.2mm)</li> <li>• Cover glass color- black</li> </ul>
RVT43ULSNWC01	<ul style="list-style-type: none"> <li>• Foam double side adhesive tape with 3M 467MP glue (total thickness 0.5mm)</li> <li>• Cover glass - black</li> </ul>
RVT43ULSNWC02	<ul style="list-style-type: none"> <li>• Without tape</li> <li>• Cover glass color- black</li> </ul>
RVT43ULSNWC03	<ul style="list-style-type: none"> <li>• Double side adhesive tape with 3M 467MP glue (total thickness 0.2mm)</li> <li>• Cover glass color- white</li> </ul>
RVT43ULSNWC04	<ul style="list-style-type: none"> <li>• Foam double side adhesive tape with 3M 467MP glue (total thickness 0.5mm)</li> <li>• Cover glass color- white</li> </ul>
RVT43ULSNWC05	<ul style="list-style-type: none"> <li>• Without tape</li> <li>• Cover glass color- white</li> </ul>

## 11 CUSTOMIZATION LEVEL

Beside standard product (**BASIC LEVEL**), there are two levels of product customization available:

1. **ADVANCED LEVEL**
2. **PROFESSIONAL LEVEL**

**Basic level** - standard version of product with black or white cover glass color.

**Advanced level**- product with modified cover glass color, company logo or with special transparent spots for diodes.



**Professional level**- product with changed panel parameters including glass dimension and shapes.



For more information go to <http://riverdi.com/uxtouch/>.

## 12 RELIABILITY TEST

NO.	TEST ITEM	TEST CONDITION
1	High Temperature Storage	80±2°C/240hours
2	Low Temperature Storage	-30±2°C/240hours
3	High Temperature Operating	70±2°C/240hours
4	Low Temperature Operating	-20±2°C/240hours
5	Temperature Cycle	-30±2°C~25~80±2°C × 20 cycles (30min.) (5min.) (30min.)
6	Damp Proof Test	60°C ±5°C × 90%RH/240hours
7	Vibration Test	Frequency 10Hz~55Hz Amplitude of vibration : 1.5mm Sweep: 10Hz~55Hz~10Hz X, Y, Z 2 hours for each direction.
8	Package Drop Test	Height:60 cm 1 corner,3 edges,6 surfaces
9	ESD Test	Air: ±4KV 150pF/330Ω 5 times Contact: ±2KV 150pF/330Ω 5 time



## 13 LEGAL INFORMATION

Riverdi makes no warranty, either expressed or implied with respect to any product, and specifically disclaims all other warranties, including, without limitation, warranties for merchantability, non-infringement and fitness for any particular purpose. Information about device are the property of Riverdi and may be the subject of patents pending or granted. It is not allowed to copy or disclosed this document without prior written permission.

Riverdi endeavors to ensure that the all contained information in this document are correct but does not accept liability for any error or omission. Riverdi products are in developing process and published information may be not up to date. Riverdi reserves the right to update and makes changes to Specifications or written material without prior notice at any time. It is important to check the current position with Riverdi.

Images and graphics used in this document are only for illustrative the purpose. All images and graphics are possible to be displayed on the range products of Riverdi, however the quality may vary. Riverdi is no liable to the buyer or to any third part for any indirect, incidental, special, consequential, punitive or exemplary damages (including without limitation lost profits, lost savings, or loss of business opportunity) relating to any product, service provided or to be provided by Riverdi, or the use or inability to use the same, even if Riverdi has been advised of the possibility of such damages.

Riverdi products are not fault tolerant nor designed, manufactured or intended for use or resale as on line control equipment in hazardous environments requiring fail – safe performance, such as in the operation of nuclear facilities, aircraft navigation or communication systems, air traffic control, direct life support machines or weapons systems in which the failure of the product could lead directly to death, personal injury or severe physical or environmental damage ('High Risk Activities'). Riverdi and its suppliers specifically disclaim any expressed or implied warranty of fitness for High Risk Activities. Using Riverdi products and devices in 'High Risk Activities' and in any other application is entirely at the buyer's risk, and the buyer agrees to defend, indemnify and hold harmless Riverdi from any and all damages, claims or expenses resulting from such use. No licenses are conveyed, implicitly or otherwise, under any Riverdi intellectual property rights.



## X-ON Electronics

Largest Supplier of Electrical and Electronic Components

*Click to view similar products for [Display Modules](#) category:*

*Click to view products by [Riverdi](#) manufacturer:*

Other Similar products are found below :

[LCD-WVGA-7IN-1](#) [P6153-PR](#) [TDP0700T800480PCAP](#) [P6171DPR-DC-RS](#) [99-47-02033A](#) [P6171DPR-DC-U](#) [96LEDK-A215FH25NF5](#)  
[IDK-1121WR-30FHA1E](#) [IDK-104R-32SVI1](#) [WF70GTIAGDNT0#](#) [G1619W02BBW01](#) [MIKROMEDIA 4 FOR STM32F4 CAPACITIVE FPI](#)  
[MIKROMEDIA 3 FOR STM32F4 CAPACITIVE FPI](#) [PH320240T023-IHC09](#) [1148693](#) [1148689](#) [PIM537](#) [TN0216ANVNANN-GN00](#)  
[TN0104ANVAANN-GN00](#) [TN0181ANVNANN-GN00](#) [12121000](#) [MIKROMEDIA FOR DSPIC33](#) [MIKROMEDIA FOR PIC24](#)  
[MIKROMEDIA FOR PIC32](#) [MIKROMEDIA FOR STELLARIS M3](#) [MIKROMEDIA FOR XMEGA](#) [MIKROMEDIA HMI 3.5 RES](#)  
[MIKROMEDIA HMI 5](#) [MIKROMEDIA PLUS FOR FT90X](#) [MIKROMEDIA PLUS FOR PIC32MX7 SHIELD](#) [MIKROMEDIA PROTO](#)  
[SHIELD](#) [MIKROMEDIA 5 FOR TIVA](#) [MIKROMEDIA 5 FOR TIVA SHIELD](#) [MIKROMEDIA 7 FOR STM32F4](#) [MIKROMEDIA](#)  
[CONNECT SHIELD](#) [MIKROMEDIA FOR ARM](#) [MIKROMEDIA FOR DSPIC33EP](#) [MIKROMEDIA FOR PSOC5LP](#) [MIKROMEDIA](#)  
[GAMING SHIELD](#) [MIKROMEDIA HMI 4.3 USB](#) [MIKROMEDIA HMI 5 RES](#) [MIKROMEDIA HMI 5 USB](#) [MIKROMEDIA HMI 7](#)  
[MIKROMEDIA HMI BREAKOUT BOARD](#) [MIKROMEDIA PLUS FOR PIC32MX7](#) [MIKROMEDIA PLUS FOR STM32](#)  
[RVT28AEFNWN00](#) [RVT28UEFNWC01](#) [RVT28UEFNWC03](#) [RVT28UEFNWC05](#)