



ON Semiconductor®

<http://onsemi.com>

LB1867M

Monolithic Digital IC 2-phase Brushless Fan Motor Driver

Overview

The LB1867M is a 2-phase unipolar brushless motor driver. With only a few peripheral parts, lockup protection and automatic recovery can be implemented. The IC can be configured for 12V or 24V operation and a wide range of variations, from Low speed to H-High speed and from 60cm to 120cm square using the same PCB. This makes it easy to design highly reliable fan motor installations.

Features

- Output protection Zener diode with variable withstand voltage
Z1, Z2 pins open: $V_{OLM} = 57V$ (24V specification)
Z1, Z2 pins shorted: $V_{OLM} = 32V$ (12V specification)
External Zener diode connected across Z1 – VCC pins: support for fans with large drive current
- External resistor allows configuration for 12V or 24V
- Direct Hall element connection possible (built-in Hall amplifier with hysteresis supports core without auxiliary electrode)
- Built-in output transistor with 1.0A output current (strengthened negative-current support for core without auxiliary electrode)
- Built-in rotation detection function: Low during rotation and High during stop
- Built-in lockup protection with automatic recovery
- Built-in thermal shutdown

Specifications

Absolute Maximum Ratings at $T_a = 25^\circ C$

Parameter	Symbol	Conditions	Ratings	Unit
Maximum input current	$I_{CC\ max}$	$t \leq 20ms$	200	mA
Maximum applied output voltage	$V_{OUT\ max}$		Internal	V
Maximum output current	$I_{OUT\ max}$		1.0	A
Maximum current flowing into RD pin	$I_{RD\ max}$		10	mA
Maximum RD applied voltage	$V_{RD\ max}$		30	V
Allowable power dissipation	$P_d\ max$	Mounted on a specified board *	800	mW
Operating temperature	T_{opr}		-30 to +80	$^\circ C$
Storage temperature	T_{stg}		-55 to +150	$^\circ C$

* Specified board: 20mm × 15mm × 1.5mm, glass epoxy board.

Stresses exceeding Maximum Ratings may damage the device. Maximum Ratings are stress ratings only. Functional operation above the Recommended Operating Conditions is not implied. Extended exposure to stresses above the Recommended Operating Conditions may affect device reliability.

LB1867M

Allowable Operating Ranges at $T_a = 25^\circ\text{C}$

Parameter	Symbol	Conditions	Ratings	Unit
Input current range	I_{CC}		6.0 to 50	mA
Common mode input voltage range	V_{ICM}		0.2 to $V_{IN}-1.5$	V

Electrical Characteristics at $T_a = 25^\circ\text{C}$, $I_{CC} = 10\text{mA}$

Parameter	Symbol	Conditions	Ratings			Unit
			min	typ	max	
Output limiter withstand voltage	V_{OLM1}	Z1, Z2 open	54	57	60	V
	V_{OLM2}	Z1, Z2 short	31	33	35	V
Output saturation voltage	V_{Osat1}	$I_O = 0.5\text{A}$		0.95	1.2	V
	V_{Osat2}	$I_O = 1.0\text{A}$		1.15	1.5	V
V_{IN} voltage	V_{IN}	$I_{CC} = 7.0\text{mA}$	6.4	6.7	7.0	V
Hall input sensitivity (at zero peak)	V_{HN}	Including offset and hysteresis			20	mV
RD output saturation voltage	V_{RDSat}	$I_{RD} = 5\text{mA}$		0.1	0.3	V
CT drain current	I_{C1}	C = GND	2.7	3.8	4.9	μA
CT discharge current	I_{C2}	C = V_{IN}	0.19	0.30	0.41	μA
Comp input threshold voltage	V_{TH1}		0.77	$0.8V_{IN}$	0.83	V
	V_{TH2}		0.42	$0.45V_{IN}$	0.48	V
Thermal protection operating temperature	TSD	Design target value *		180		$^\circ\text{C}$
Thermal protection circuit hysteresis	ΔTSD	Design target value *		40		$^\circ\text{C}$

* Design target value, Do not measurement.

Package Dimensions

unit : mm (typ)

3111A

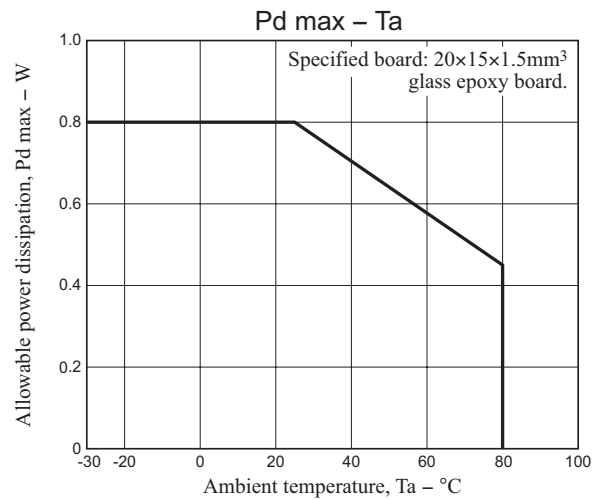
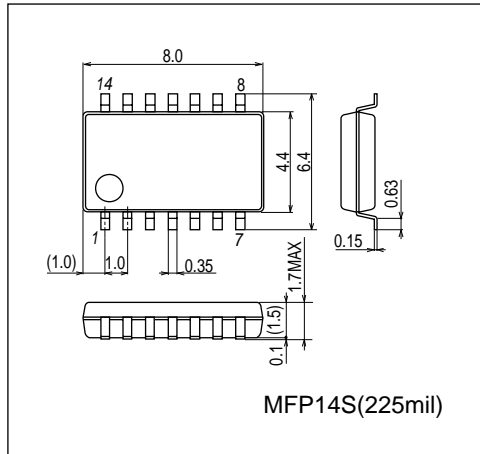

LB1867M

Pin Assignment

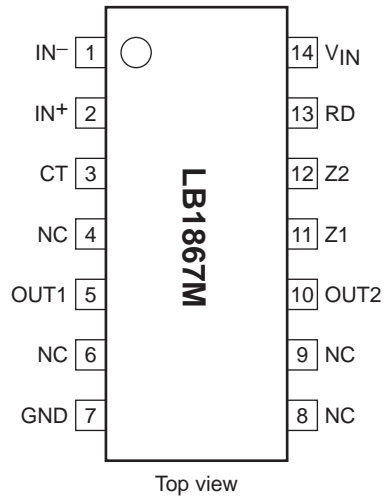

Pin Function

Pin No.	Pin name	Function
1	IN ⁻	Hall input + pin. Hysteresis amplifier
2	IN ⁺	Hall input – pin. Hysteresis amplifier
3	CT	Lockup protection time setting capacitor pin (0.47 to 4.7μF).
5	OUT1	Output 1 pin.
10	OUT2	Output 2 pin.
7	GND	GND pin.
11	Z1	External Zener diode pin (external Zener diode to be connected between power supply and Z1).
12	Z2	Kickback absorption voltage alteration pin (shorted to Z1: 12V operation).
13	RD	Lockup detection pin (latch type).
14	V _{IN}	Regulated power supply input pin (limiting resistor to be inserted between power supply and V _{IN}).

Truth Table

IN ⁺	IN ⁻	CT	OUT1	OUT2	RD
H	L	L	H	L	L
L	H	L	L	H	L
H	L	H	H	H	H
L	H	H	H	H	H

* RD is a latch type output

LB1867M

Block Diagram

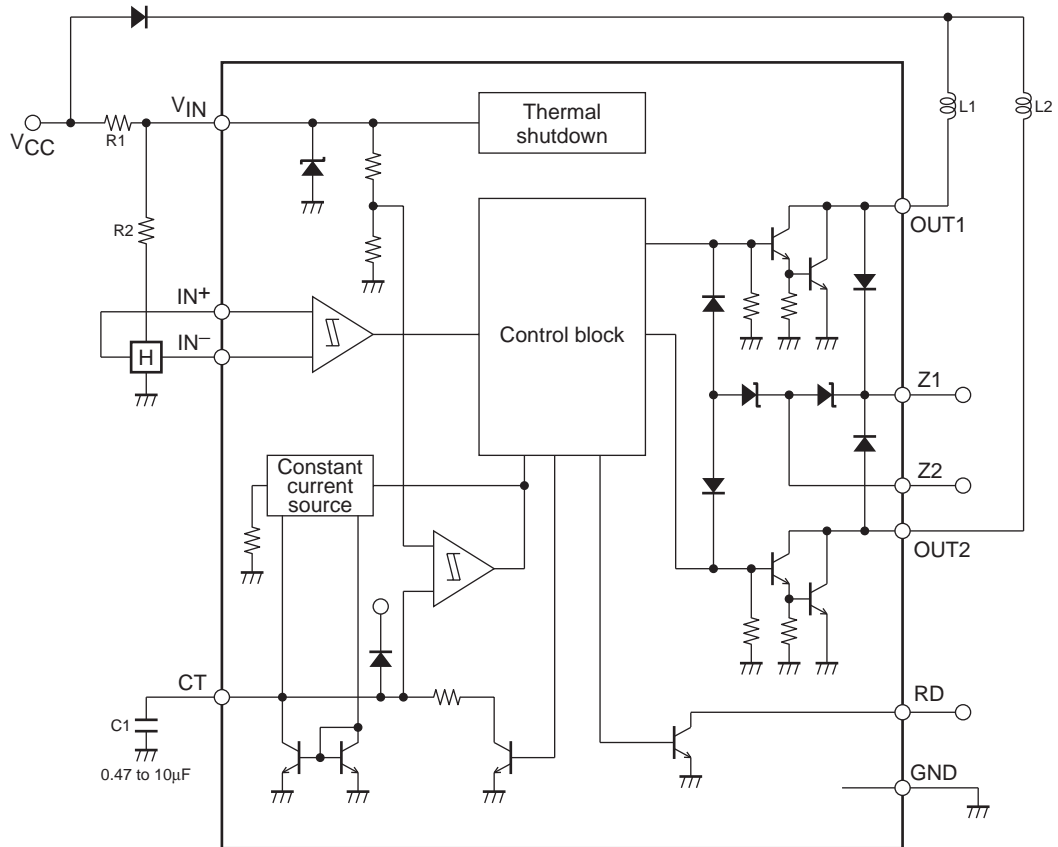

Application Circuit Example

(1) 12V supply voltage

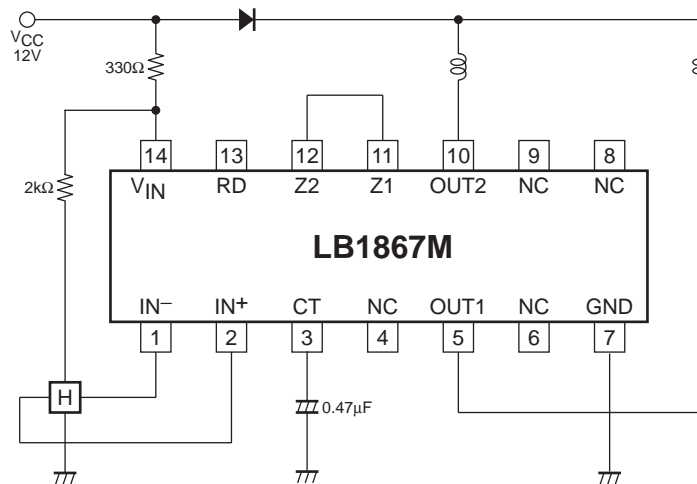

LB1867M

(2) 24V supply voltage

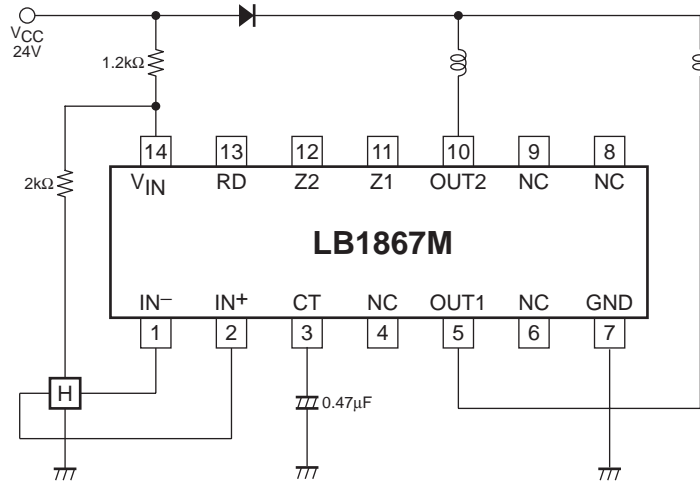

(3) High-Power Fan (120mm-HH-Speed)

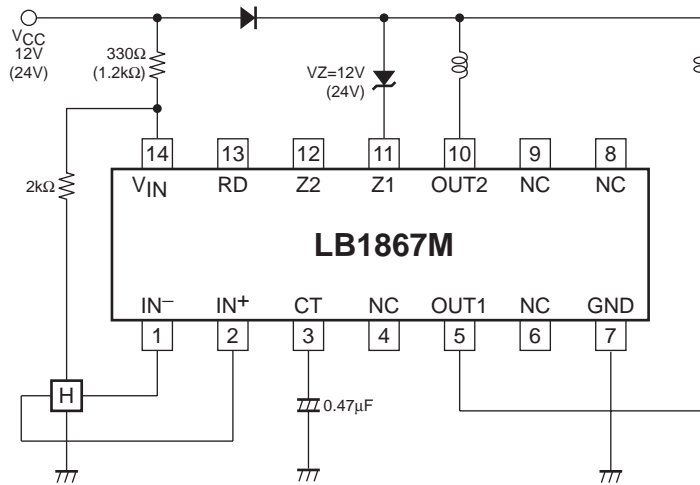

ON Semiconductor and the ON logo are registered trademarks of Semiconductor Components Industries, LLC (SCILLC). SCILLC owns the rights to a number of patents, trademarks, copyrights, trade secrets, and other intellectual property. A listing of SCILLC's product/patent coverage may be accessed at www.onsemi.com/site/pdf/Patent-Marking.pdf. SCILLC reserves the right to make changes without further notice to any products herein. SCILLC makes no warranty, representation or guarantee regarding the suitability of its products for any particular purpose, nor does SCILLC assume any liability arising out of the application or use of any product or circuit, and specifically disclaims any and all liability, including without limitation special, consequential or incidental damages. "Typical" parameters which may be provided in SCILLC data sheets and/or specifications can and do vary in different applications and actual performance may vary over time. All operating parameters, including "Typicals" must be validated for each customer application by customer's technical experts. SCILLC does not convey any license under its patent rights nor the rights of others. SCILLC products are not designed, intended, or authorized for use as components in systems intended for surgical implant into the body, or other applications intended to support or sustain life, or for any other application in which the failure of the SCILLC product could create a situation where personal injury or death may occur. Should Buyer purchase or use SCILLC products for any such unintended or unauthorized application, Buyer shall indemnify and hold SCILLC and its officers, employees, subsidiaries, affiliates, and distributors harmless against all claims, costs, damages, and expenses, and reasonable attorney fees arising out of, directly or indirectly, any claim of personal injury or death associated with such unintended or unauthorized use, even if such claim alleges that SCILLC was negligent regarding the design or manufacture of the part. SCILLC is an Equal Opportunity/Affirmative Action Employer. This literature is subject to all applicable copyright laws and is not for resale in any manner.

X-ON Electronics

Largest Supplier of Electrical and Electronic Components

Click to view similar products for [Motor/Motion/Ignition Controllers & Drivers](#) category:

Click to view products by [ON Semiconductor](#) manufacturer:

Other Similar products are found below :

[LV8133JA-ZH](#) [LV8169MUTBG](#) [LV8774Q-AH](#) [LV8860PV-TLM-H](#) [MC33931EKR2](#) [FSB50250UTD](#) [FSB50550TB2](#) [FSBF15CH60BTH](#)
[FSBS10CH60T](#) [MP6507GR-P](#) [MP6508GF](#) [MSVCPM2-63-12](#) [MSVGW45-14-2](#) [MSVGW54-14-5](#) [NTE7043](#) [CAT3211MUTAG](#) [LA6245P-CL-TLM-E](#) [LA6245P-TLM-E](#) [LA6565VR-TLM-E](#) [LB11650-E](#) [LB1694N-E](#) [LB1837M-TLM-E](#) [LB1845DAZ-XE](#) [LC898111AXB-MH](#)
[LC898300XA-MH](#) [SS30-TE-L-E](#) [STK531-345A-E](#) [STK581U3A0D-E](#) [STK58AUNP0D-E](#) [STK621-068C-E](#) [STK621-140C](#) [STK621-728S-E](#)
[STK625-728-E](#) [STK672-400B-E](#) [STK672-432AN-E](#) [STK672-432BN-E](#) [STK672-440AN-E](#) [STK672-442AN-E](#) [AMIS30621AUA](#)
[FSB50550ASE](#) [26700](#) [LV8161MUTAG](#) [LV8281VR-TLM-H](#) [LV8702V-TLM-H](#) [LV8734VZ-TLM-H](#) [LV8773Z-E](#) [LV8807QA-MH](#)
[MC33932EK](#) [MCP8024T-H/MP](#) [TND027MP-AZ](#)