



0.2W Medium Power Thin Series Datasheet



Features:

- PLCC-2 package.
- Silicone resin.
- GaN technology Chip Material.
- High luminous Intensity and high efficiency.
- High Color rendering index.
- Low Color Tolerance Adjustment.
- 120°Wide viewing angle.
- Compatible with automatic placement equipment.
- Compatible with reflow solder process.
- Suitable for all SMT assembly methods.
- Doesn't contain restriction Substance, comply ROHS standard.

Typical Application:

- Indoor Displays.
- Backlighting (illuminated advertising, general lighting).
- Substitution of fluorescent lamps.
- Interior Automotive Lighting.
- Signal and Symbol Luminaire.

Contents

01. General Information
02. Package dimensions
03. Absolute maximum rating
04. Electrical optical characteristics
05. BIN range
06. Chromaticity Coordinates & Bin grading diagram
07. Package label
08. Soldering pad dimensions
09. Soldering conditions
10. Package tape specifications
11. Typical electro-optical characteristics curves
12. Storage and application notices
13. Notes

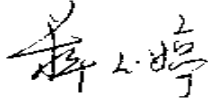
Customer confirm	Approved by	Checked by	Issued by
		/	

◆ General Information

Product Nomenclature

The following table describes the available color, color rendering index (Ra) and product series. For more flux and forward voltage information, please consult the Bin range of Chromaticity Coordinates and Chromaticity Coordinates & Bin grading diagram.

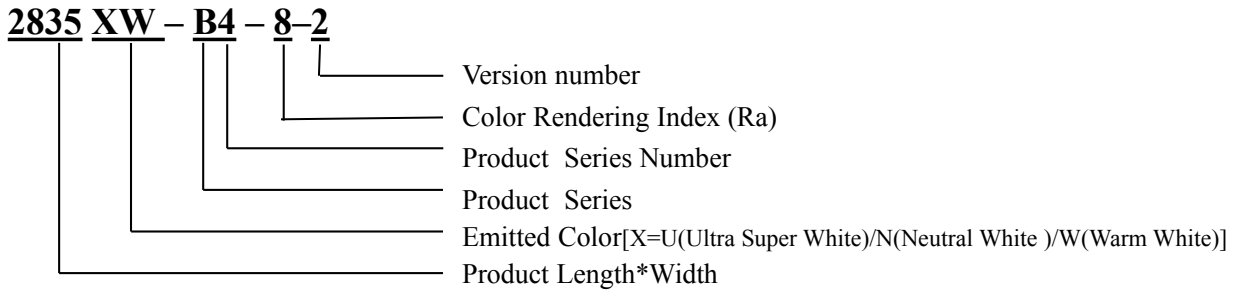

◆ Package Dimensions

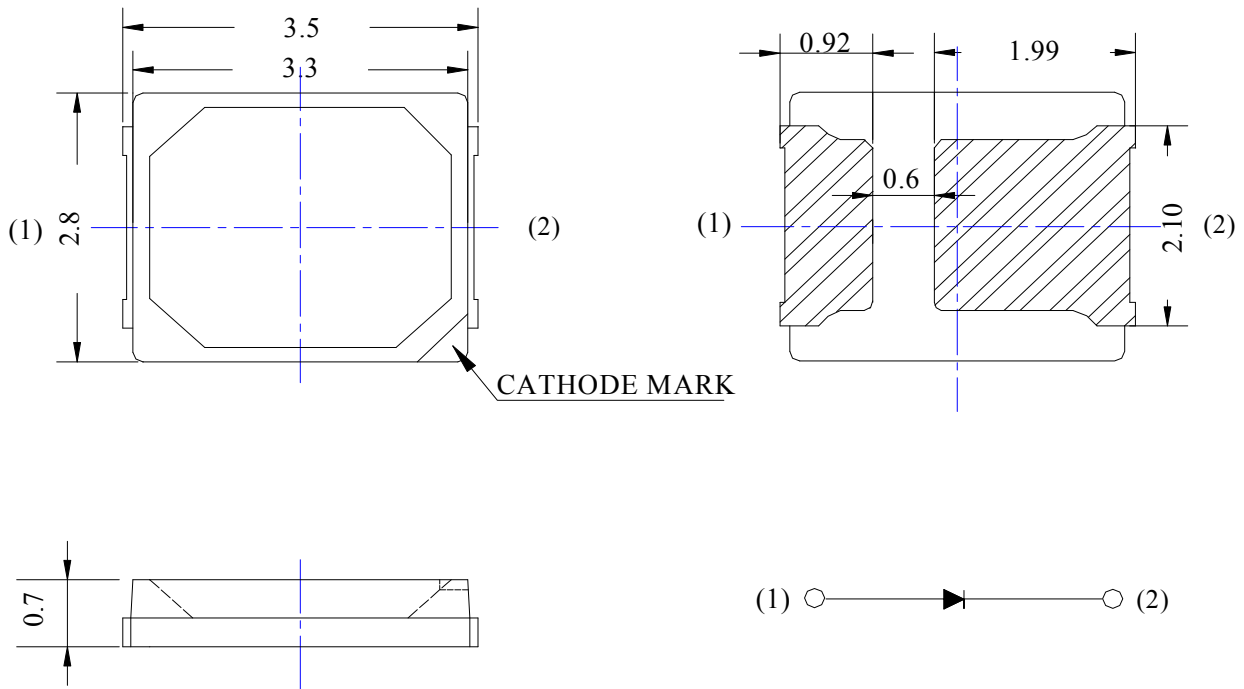

Unit: mm

Figure: 0.2W medium power thin series circuit diagram

Tolerance: ±0.2mm unless otherwise noted

Electrodes: Ag Plating Copper Alloy

Encapsulating Resin: Silicon Resin

Package: Heat-Resistant Polymer

◆ **Absolute Maximum Rating (Ta=25°C)**

The following table describe absolute maximum ratings of 0.2 W medium power thin series.

Parameter	Symbol	Max.	Unit
Power Dissipation	Pd	180	mW
Pulse Forward Current*	I _{FP}	90	mA
DC Forward Current	I _F	60	mA
Reverse Voltage	V _R	5	V
Operating Temperature Range	Topr	-40°C ~ 85°C	°C
Storage Temperature Range	Tstg	-40°C ~ 100°C	°C

● I_{FP} condition: pulse width ≤0.1ms, duty cycle ≤1/10.

◆ **Optical and Electrical Characteristics (Ta=25°C)**

Luminous intensity characteristics at Ta=25°C for 0.2W medium power thin series.

Part Name	TC /K	Ra	Luminous Flux / lm		Luminous intensity/mcd	I _R (V _R =5V) / uA	Typ. Δλ / nm	2θ _{1/2} /°	Test Condition
		Typ.	Min	Max.					
2835WW-B4-8-2	2580-2870K	80	17	20	5000-7200	<10	120	120	60 mA
	2870-3220K		19	23	6000-8600				
	3220-3710K		19	23	6000-8600				
2835NW-B4-8-2	3710-4260K	80	20	24	6000-8600	<10	25	120	
	4260-4745K								
2835UW-B4-8-2	4745-5312K	80	20	24	6000-8600	<10	25	120	
	5312-6020K		20	24					
	6020-7040K		20	24					
	7040-7650K		19	23					

Note: 1. Tolerance of Luminous Intensity ±10%.

2. Tolerance of Forward voltage ±0.05V.

3. Luminous Flux is measured by WENRUN's equipment on bare chips, which is only for your reference, not 100% test value. The manufacturer do not guarantee this value.

◆ **BIN range**

Forward voltage (tolerance is $\pm 0.05V$ @ $I_F=60$ mA):

BIN CODE	Min. (V)	Max. (V)
R	2.8	2.9
S	2.9	3.0
T	3.0	3.1
U	3.1	3.2
V	3.2	3.3
W	3.3	3.4

Luminous intensity (tolerance is $\pm 10\%$ @ $I_F=60$ mA):

BIN CODE	Min. (mcd)	Max. (mcd)
B8	5000	6000
B9	6000	7200
B10	7200	8600

◆ **Chromaticity Coordinates & Bin grading diagram**

Bin range of Chromaticity Coordinates (tolerance is ± 0.01 @ $I_F=60$ mA):

CCT	Bin Code	X1	Y1	X2	Y2	X3	Y3	X4	Y4
2580-2725 K	27A	0.4814	0.4317	0.4681	0.4291	0.4576	0.4100	0.4698	0.4124
	27B	0.4698	0.4124	0.4576	0.4100	0.4477	0.3920	0.4588	0.3941
	27E	0.4814	0.4317	0.4681	0.4291	0.4755	0.4425	0.4895	0.4452
	27G	0.4588	0.3941	0.4477	0.3920	0.4413	0.3805	0.4519	0.3825
2725-2870 K	27C	0.4681	0.4291	0.4563	0.4260	0.4464	0.4071	0.4576	0.4100
	27D	0.4576	0.4100	0.4464	0.4071	0.4371	0.3892	0.4477	0.3920
	27F	0.4681	0.4291	0.4563	0.4260	0.4632	0.4392	0.4755	0.4425
	27H	0.4477	0.3920	0.4371	0.3892	0.4312	0.3779	0.4413	0.3805
2870-3045 K	30A	0.4563	0.4260	0.4423	0.4215	0.4336	0.4030	0.4464	0.4071
	30B	0.4464	0.4071	0.4336	0.4030	0.4254	0.3856	0.4371	0.3892
	30E	0.4563	0.4260	0.4423	0.4215	0.4484	0.4344	0.4632	0.4392
	30G	0.4371	0.3892	0.4254	0.3856	0.4202	0.3745	0.4312	0.3779
3045-3220 K	30C	0.4423	0.4215	0.4300	0.4165	0.4221	0.3984	0.4336	0.4030
	30D	0.4336	0.4030	0.4221	0.3984	0.4145	0.3813	0.4254	0.3856

	30F	0.4423	0.4215	0.4300	0.4165	0.4356	0.4292	0.4484	0.4344
	30H	0.4254	0.3856	0.4145	0.3813	0.4097	0.3704	0.4202	0.3745
3220-3465 K	35A	0.4300	0.4165	0.4137	0.4090	0.4071	0.3916	0.4221	0.3984
	35B	0.4221	0.3984	0.4071	0.3916	0.4007	0.3751	0.4145	0.3813
	35E	0.4300	0.4165	0.4137	0.4090	0.4184	0.4212	0.4356	0.4292
	35G	0.4145	0.3813	0.4007	0.3751	0.3967	0.3646	0.4097	0.3704
3465-3710 K	35C	0.4137	0.4090	0.3994	0.4013	0.3939	0.3847	0.4071	0.3916
	35D	0.4071	0.3916	0.3939	0.3847	0.3888	0.3689	0.4007	0.3751
	35F	0.4137	0.4090	0.3994	0.4013	0.4032	0.4130	0.4184	0.4212
	35H	0.4007	0.3751	0.3888	0.3689	0.3854	0.3588	0.3967	0.3646
3710-3985 K	40A	0.4004	0.4042	0.3863	0.3958	0.3818	0.3798	0.3948	0.3874
	40B	0.3948	0.3874	0.3818	0.3798	0.3776	0.3645	0.3896	0.3715
	40E	0.4004	0.4042	0.3863	0.3958	0.3902	0.4099	0.4052	0.4189
	40G	0.3896	0.3715	0.3776	0.3645	0.3736	0.3501	0.3846	0.3564
3985-4260 K	40C	0.3863	0.3958	0.3735	0.3874	0.3701	0.3721	0.3818	0.3798
	40D	0.3818	0.3798	0.3701	0.3721	0.3668	0.3576	0.3776	0.3645
	40F	0.3863	0.3958	0.3735	0.3874	0.3765	0.4007	0.3902	0.4099
	40H	0.3776	0.3645	0.3668	0.3576	0.3637	0.3439	0.3736	0.3501
4260-4500 K	45A	0.3735	0.3874	0.3634	0.3802	0.3609	0.3657	0.3701	0.3721
	45B	0.3701	0.3721	0.3609	0.3657	0.3585	0.3519	0.3668	0.3576
	45E	0.3735	0.3874	0.3634	0.3802	0.3657	0.3929	0.3765	0.4007
	45G	0.3668	0.3576	0.3585	0.3519	0.3563	0.3389	0.3637	0.3439
4500-4745 K	45C	0.3634	0.3802	0.3546	0.3734	0.3528	0.3595	0.3609	0.3657
	45D	0.3609	0.3657	0.3528	0.3595	0.3510	0.3463	0.3585	0.3519
	45F	0.3634	0.3802	0.3546	0.3734	0.3563	0.3855	0.3657	0.3929
	45H	0.3585	0.3519	0.3510	0.3463	0.3494	0.3337	0.3563	0.3389
4745-5028 K	50A	0.3549	0.3758	0.3457	0.3684	0.3446	0.3552	0.3531	0.3618
	50B	0.3531	0.3618	0.3446	0.3552	0.3436	0.3426	0.3513	0.3485
	50E	0.3549	0.3758	0.3457	0.3684	0.3471	0.3856	0.3574	0.3940
	50G	0.3513	0.3485	0.3436	0.3426	0.3424	0.3285	0.3494	0.3337
5028-5312 K	50C	0.3457	0.3684	0.3373	0.3614	0.3369	0.3488	0.3446	0.3552
	50D	0.3446	0.3552	0.3369	0.3488	0.3365	0.3368	0.3436	0.3426
	50F	0.3457	0.3684	0.3373	0.3614	0.3379	0.3777	0.3471	0.3856
	50H	0.3436	0.3426	0.3365	0.3368	0.3360	0.3234	0.3424	0.3285
5312-5665 K	57A	0.3373	0.3614	0.3291	0.3543	0.3291	0.3423	0.3369	0.3488
	57B	0.3369	0.3488	0.3291	0.3423	0.3291	0.3307	0.3365	0.3368
	57E	0.3373	0.3614	0.3291	0.3543	0.3291	0.3700	0.3379	0.3777
	57G	0.3365	0.3368	0.3291	0.3307	0.3291	0.3179	0.3360	0.3234
5665-6020 K	57C	0.3291	0.3543	0.3217	0.3478	0.3222	0.3362	0.3291	0.3423
	57D	0.3291	0.3423	0.3222	0.3362	0.3226	0.3252	0.3291	0.3307
	57F	0.3291	0.3543	0.3217	0.3478	0.3212	0.3627	0.3291	0.3700
	57H	0.3291	0.3307	0.3226	0.3252	0.3231	0.3128	0.3291	0.3179

6020-6530 K	65A	0.3217	0.3498	0.3108	0.3386	0.3123	0.3282	0.3221	0.3381
	65B	0.3221	0.3381	0.3123	0.3282	0.3138	0.3182	0.3226	0.3270
	65E	0.3212	0.3627	0.3092	0.3503	0.3108	0.3386	0.3217	0.3498
	65G	0.3226	0.3270	0.3138	0.3182	0.3156	0.3054	0.3231	0.3128
6530-7040 K	65C	0.3108	0.3386	0.3027	0.3304	0.3048	0.3206	0.3123	0.3282
	65D	0.3123	0.3282	0.3048	0.3206	0.3067	0.3113	0.3138	0.3182
	65F	0.3092	0.3503	0.3005	0.3412	0.3027	0.3304	0.3108	0.3386
	65H	0.3138	0.3182	0.3067	0.3113	0.3092	0.2993	0.3156	0.3054
7040-7650 K	70A	0.3005	0.3412	0.3027	0.3304	0.2945	0.3216	0.2916	0.3316
	70B	0.3027	0.3304	0.2945	0.3216	0.2970	0.3126	0.3048	0.3206
	70C	0.3048	0.3206	0.2970	0.3126	0.2995	0.3039	0.3067	0.3113
	70D	0.3067	0.3113	0.2995	0.3039	0.3027	0.2928	0.3092	0.2993

Please refer to CIE 1931 Chromaticity diagram

● Chromaticity Coordinates & Bin grading diagram (IF=60 mA):

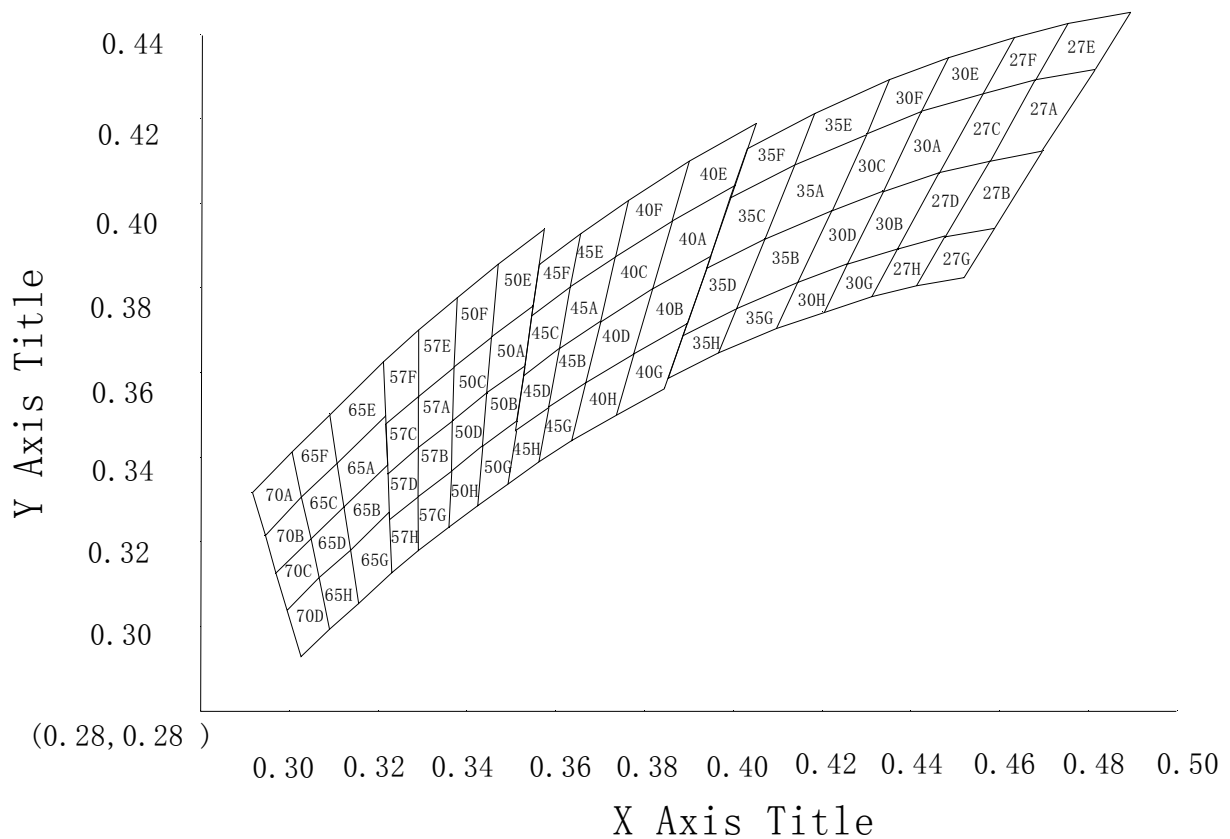

◆ **Typical Electro-Optical Characteristics Curves:**

Relative Luminous Intensity Vs. Wavelength

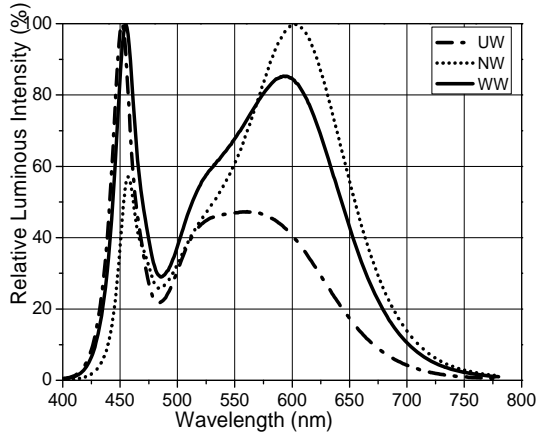

Forward Current vs Forward Voltage at Ta=25°C

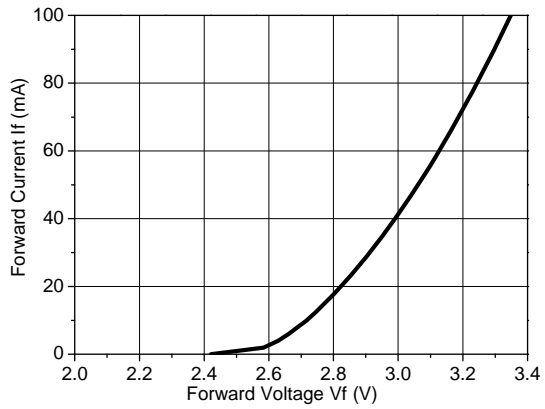

Forward Current Vs. Ambient Temperature

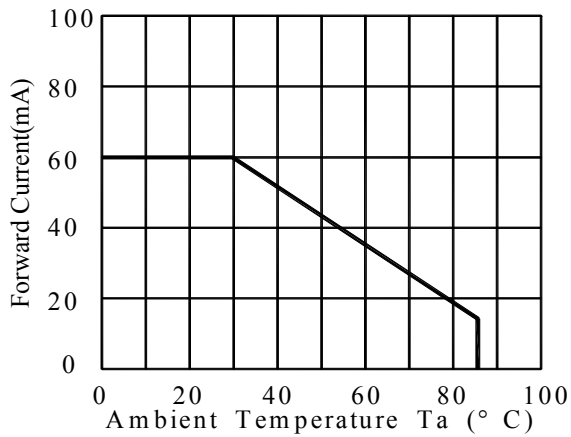

Forward Current Vs. Relative Luminosity Ta=25°C

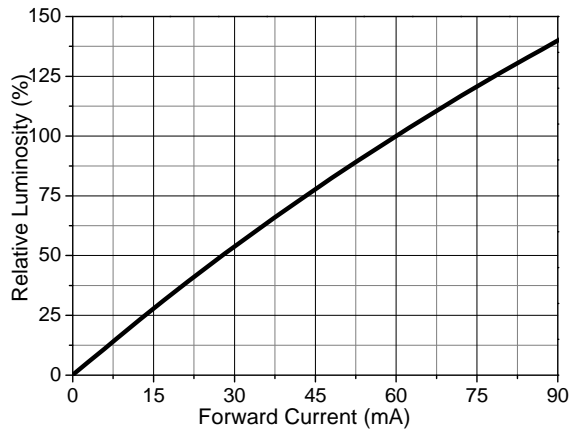

Relative Luminosity Vs. Ambient Temperature

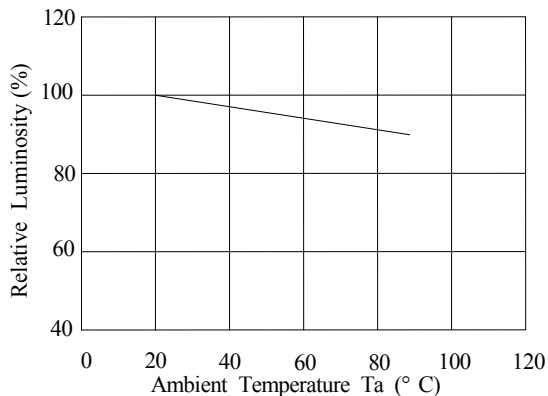

Radiation diagram

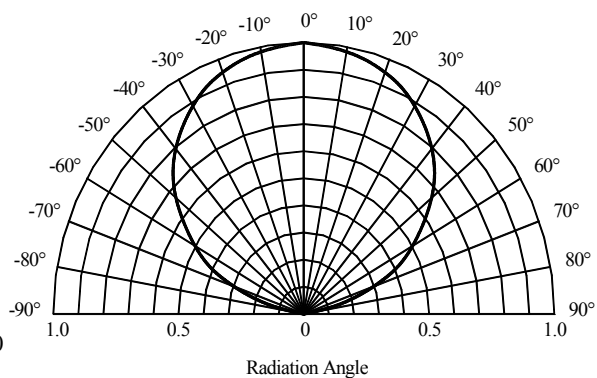

◆ **Package Label: (For example)**

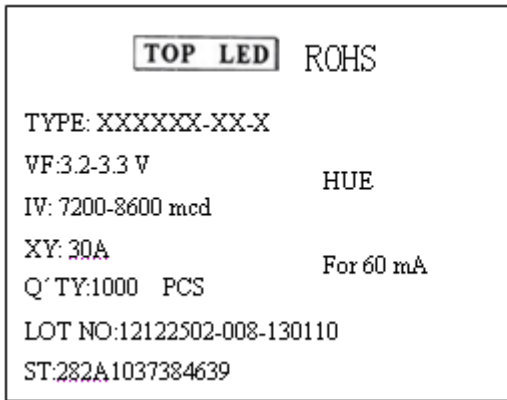

- ← LED Type
- ← Part No. ↵
- ← Parameter Classing ↵
- ← Quantity ↵
- ← Sealing Date (year-month-day)

◆ **Soldering Pad Dimensions**

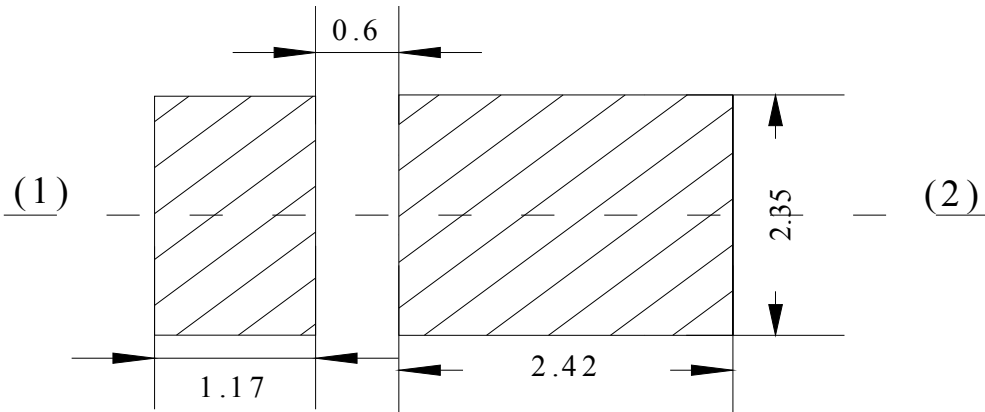

◆ **Soldering Conditions (Maximum allowable soldering conditions)**

Reflow soldering profile <Pb-free solder>

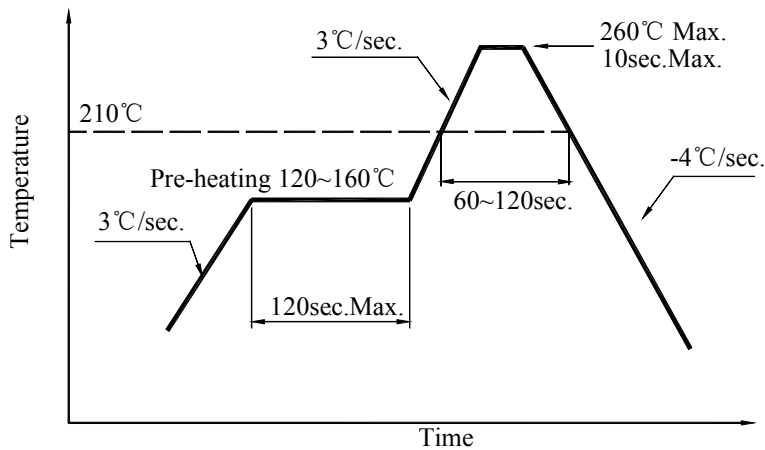

- Reflow soldering should not be done more than two times.
- Do not stress its resin while soldering.
- After soldering, do not warp the circuit board.
- Pay attention to electrostatic (ESD).

◆ Package Tape Specifications (4000pcs/Reel) :

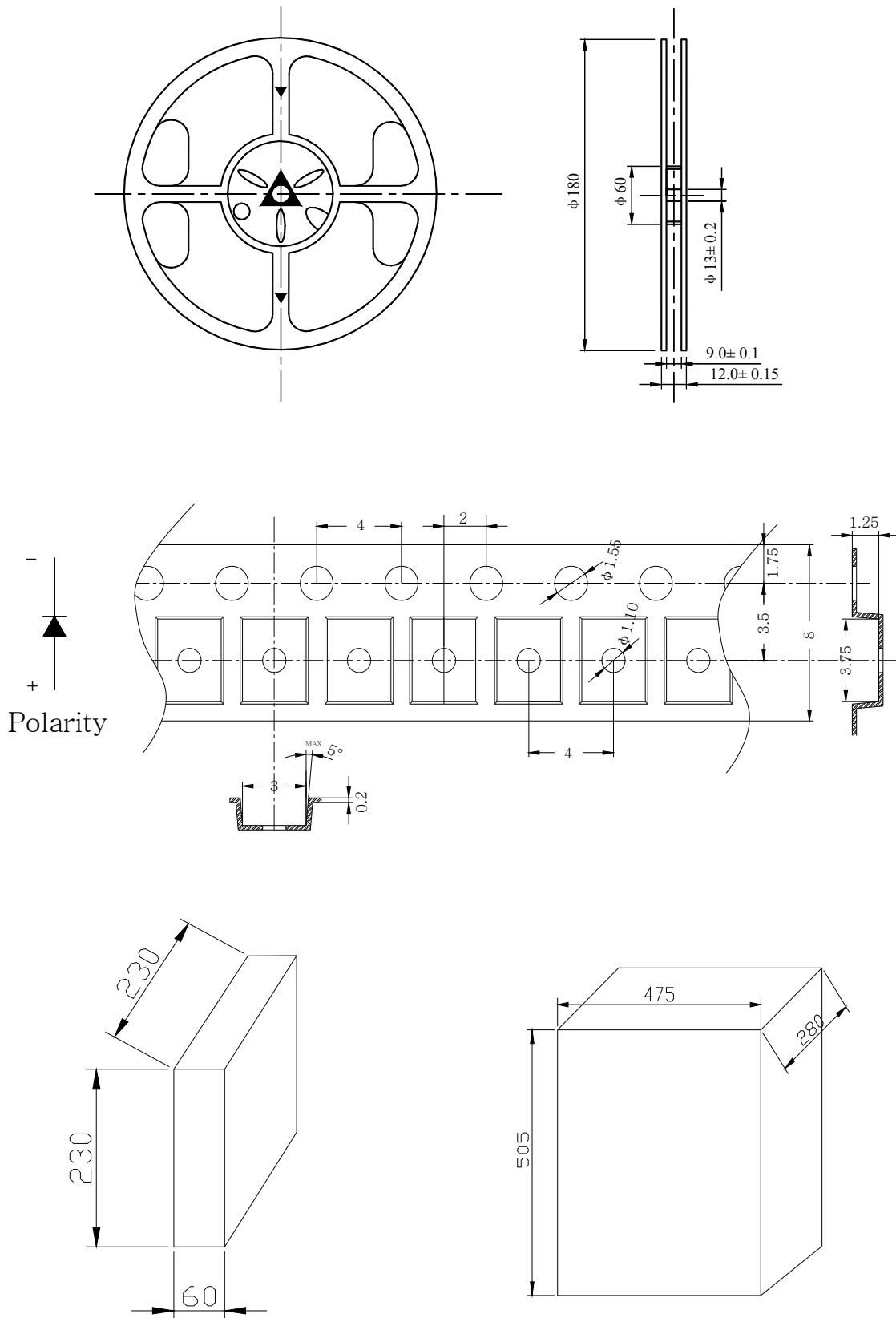

5 Reels in one Box

16 Boxes in one Carton

◆ Storage and application notices

1. Storage

1. Calculated shelf life in sealed bag: 12 months at $<30^{\circ}\text{C}$ and $<90\%$ relative humidity (RH)
- 2.1 TOP LED: After bag is opened, devices that will be subjected to reflow solder or other high temperature process must be:
 - a) Mounted within: 168 hours of factory conditions $\leq 30^{\circ}\text{C}/150\%$ RH, or
 - b) Stored at ambient of $<20\%$ RH
- 2.2 CHIP LED: After bag is opened, devices that will be subjected to reflow solder or other high temperature process must be:
 - a) Mounted within: one year of factory conditions $\leq 30^{\circ}\text{C}/150\%$ RH, or
 - b) Stored at ambient of $<20\%$ RH.
3. Device require bake, before mounting, if:
 - a) Humidity indicator Card reads $>10\%$ when read at $25\pm 5^{\circ}\text{C}$
 - b) Above conditions are not metBaking condition: 24 hours at $150\pm 3^{\circ}\text{C}$ and $<5\%$ RH
4. The internal and esterand boxes can not be contacted with ground to prevent absorption of moisture;
5. No acid, alkali, salt, corrosive and explosive gas; away from sunlight and keep the environment clean;

2. Application

1. Do not use any unknown chemical liquid to clean LED, it will damage the LED resin surface; use the alcohol under the room temperature if necessary but less than 1 min, or use the ultrasonic cleaning with proper characters, such as correct power, frequency ,etc.
2. Do not touch the epoxy resin area when carrying LEDs by tweezers (as the following pictures), especially after the soldering process, the epoxy resin will turn to soft, the internal instruction will be damaged by the tweezers which cause the electric character's failure; nozzle is recommended by using SMT mounting.

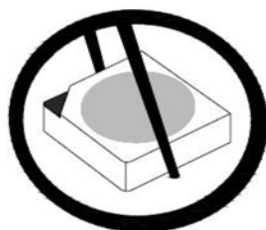

Correct



Incorrect

3. Soldering iron: double-side soldering iron with power of less than 25W; soldering temperature: less than 300°C; soldering time: less than 3sec.; 1 time completed is recommended, if the 2nd soldering process is requested, 3mins must be left to ensure the high temperature status can return to room temperature.
 - a. REFLOW soldering: set and test the temperature of the different area of REFLOW equipment in advance.
 - b. To set the peak temperature according to different SMDs, but the actual peak temperature should be less than 260 °C ,processing time should be less than 10sec, only 1 time is allowed.
4. SMDs should be soldered at the coordinated position on the PCB.
5. Note of Electrical matter:
 - ① One-way conduction, LED does not allow the reverse driving.
 - ② LED is a kind of constant current component which can not be lighted by the constant voltage mode; a smaller voltage fluctuation can cause the large current fluctuation which causes the failure of LED.

Each LED should be drove under constant current mode if in a parallel circuit design, otherwise, the colour and brightness will be nonuniform; When the environmental temperature rising, the LED junction temperature will rise, internal resistance will decrease, so the current will be increased by the constant voltage power which short the life span.
 - ③ If the brightness of lighting source can meet the requirement, we recommend using the driving current less than the rated current, in order to improve the product's reliability.
6. LED is a kind of electrostatic sensitive devises, anti-static measures have to be processed during storage and operation:
 - ① LED production workshop should lay anti-static floor and ground connection, the work table have to use the anti-static materials and cover a table mater with the surface resistance of 10^6 - $10^9\Omega$.
 - ② Production machine: REFLOW, SMT equipment, electric iron, test equipment; all the equipments must be well grounded, and the grounding alternating current impedance should be less than 1.0 Ω . A fan need to be installed on the equipments and production processes that easy to generate static electricity; the operators must wear anti-static clothing, shoes, wristband, and gloves, etc. in the process.
 - ③ LEDs must be contained in the anti-static box, and all the package material should be the anti-static materials.

7. The details electronic characters can refer to our product specification.

◆ Notes:

1、Above specification may be changed without notice. We will reserve authority on material change for above specification.

2、When using this product, please observe the absolute maximum ratings and the instructions for the specification sheets. We assume no responsibility for any damage resulting from use of the product which does not comply with the instructions included in the specification sheets.

X-ON Electronics

Largest Supplier of Electrical and Electronic Components

Click to view similar products for [High Power LEDs - White category](#):

Click to view products by [Wenrun manufacturer](#):

Other Similar products are found below :

[G42180-08](#) [B42180-08](#) [STW8Q2PA-R5-HA](#) [SZ5-M1-W0-00-V3/W2-AA](#) [LTPL-P00DWS57](#) [LZP-D0WW00-0000](#) [CLM-9-30-90-36-AC32-F4-3](#) [SZ5-M1-WW-C8-V1/V3-FA](#) [BXRC-27E2000-D-73](#) [BXRC-27G2000-D-73](#) [BXRC-30E1000-D-73](#) [BXRC-30G2000-D-73](#) [BXRC-40E1000-D-73](#) [BXRE-30G2000-B-73](#) [BXRE-30G2000-C-73](#) [BXRE-50C2001-C-74](#) [CXM-22-27-80-54-AC30-F4-3](#) [XHP50B-00-0000-0D0UH245G](#) [XHP50B-00-0000-0D0UH240G](#) [XHP50B-00-0000-0D0UG227H](#) [XHP50B-00-0000-0D0HJ245G](#) [MP-5050-8100-27-80](#) [MP-5050-6100-65-80](#) [MP-5050-6100-50-80](#) [MP-5050-6100-40-80](#) [MP-5050-6100-30-80](#) [CXM-22-30-80-54-AC30-F4-3](#) [LTW-2835SZK57](#) [BXEM-50C0000-0-000](#) [WW-WNA30TS-U1\(M1\)](#) [KW CSLPM2.CC-8L8M-4L8N](#) [KW CSLPM2.CC-8L8M-4O9Q](#) [KW DPLS32.SB-6H6J-E5P7-EG-Z264](#) [L1V1-507003V500000](#) [CXM-22-35-80-36-AC10-F3-3](#) [KW3 CGLNM1.TG-Z6QF6-EBVFFCBB46-DFGA](#) [JB5630AWT-H-H65EA0000-NZ000001](#) [XHP50B-00-0000-0D0UG430H](#) [CXM-22-35-90-54-AC40-F5-3](#) [CXM-22-35-80-54-AC40-F5-3](#) [OSM51206E1N-0.8T](#) [OSW43020C1C](#) [MP161611032290](#) [MP-1616-2103-50-90](#) [KW CULPM1.TG-Z6RF7-ebvFfcbB46-65G5](#) [KW DMLS33.SG-Z6M7-EBVFFCBB46-8E8G-700-S](#) [XPGDWT-B1-0000-00EEA](#) [XHP70B-00-0000-0D0BP450E](#) [KW DMLN33.SG-7J7K-EBVFFCBB46-8E8G-200-S](#) [ASMT-MW05-NMNS1](#)