

HC49/4H SMX Crystals

ISSUE 13 ; 28 SEPTEMBER 2004

Delivery Options

- Please contact our sales office for current leadtimes

Holder Style

- HC49/4H SMX crystals are resistance welded, hermetically sealed in an inert atmosphere with glass to metal seals securing the lead wires. The lead wires are formed into a gull wing and mounted on a plastic former

- Lower profiles available, please contact our sales office

General Specifications

- Load Capacitance (C_L): 10pF to 75pF or Series
- Drive Level: 0.5mW max
- Static Capacitance (C_0): 9pF max
- Ageing: ± 3 ppm typical per year

Standard Frequency Tolerances and Stabilities

- ± 50 ppm, ± 100 ppm

Operating Temperature Ranges

- 0 to 50°C -20 to 70°C
- 10 to 60°C -30 to 80°C

Storage Temperature Range

- -55 to 125°C

Environmental Specification

- Shock: 981m/s² for 6ms, three shocks in each direction along three mutually perpendicular planes,
- Vibration: 10 to 60Hz 0.75mm displacement, 60 to 500Hz 98.1m/s² acceleration, 30 minute in each of three mutually perpendicular planes

Solder Condition

- For typical soldering conditions, please see the relevant page in Application Notes

Marking

- Frequency only

Minimum Order Information Required

- Frequency + Holder + Frequency Tolerance @ 25°C
+ Frequency Stability + Operating Temperature Range +
Circuit Condition + Overtone Order

Outline in mm

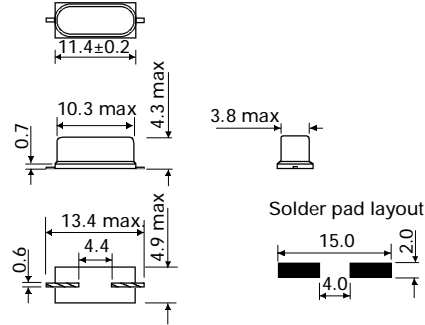

Typical Frequency Vs Temperature Curves for various angles of AT-cut crystals

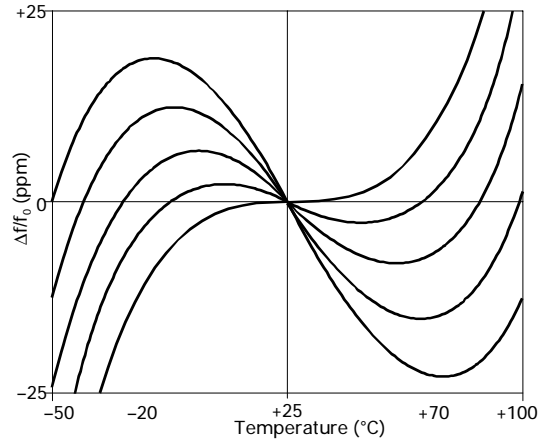

Electrical Specification – maximum limiting values

Frequency Range	Frequency Tolerance @ 25°C ±2°C	Operating Temperature Range	Frequency Stability Available Over Operating Temperature		ESR max.	Vibration Mode
			Minimum	Maximum		
3.2 to < 5.0MHz	±10ppm to ±100ppm	0 to 50°C	±15ppm	±100ppm	200Ω	Fundamental AT cut
		-10 to 60°C	±20ppm	±100ppm		
		-20 to 70°C	±20ppm	±100ppm		
		-30 to 80°C	±25ppm	±100ppm		
5.0 to < 8.0MHz	±10ppm to ±100ppm	0 to 50°C	±15ppm	±100ppm	120Ω	Fundamental AT cut
		-10 to 60°C	±20ppm	±100ppm		
		-20 to 70°C	±20ppm	±100ppm		
		-30 to 80°C	±25ppm	±100ppm		
8.0 to < 12.0MHz	±10ppm to ±100ppm	0 to 50°C	±10ppm	±100ppm	70Ω	Fundamental AT cut
		-10 to 60°C	±15ppm	±100ppm		
		-20 to 70°C	±15ppm	±100ppm		
		-30 to 80°C	±20ppm	±100ppm		
12.0 to < 25.0MHz	±10ppm to ±100ppm	0 to 50°C	±5ppm	±100ppm	50Ω	Fundamental AT cut
		-10 to 60°C	±15ppm	±100ppm		
		-20 to 70°C	±15ppm	±100ppm		
		-30 to 80°C	±20ppm	±100ppm		
25.0 to < 32.0MHz	±10ppm to ±100ppm	0 to 50°C	±10ppm	±100ppm	40Ω	Fundamental AT cut
		-10 to 60°C	±15ppm	±100ppm		
		-20 to 70°C	±15ppm	±100ppm		
		-30 to 80°C	±20ppm	±100ppm		
25.0 to < 40.0MHz	Inclusive with Frequency Stability	0 to 50°C	±50ppm	±100ppm	50Ω	Fundamental BT cut
		-10 to 60°C	±70ppm	±100ppm		
		-20 to 70°C	±100ppm	±100ppm		
28.0 to < 86.0MHz	±15ppm to ±100ppm	0 to 50°C	±15ppm	±100ppm	100Ω	3rd Overtone AT cut
		-10 to 60°C	±20ppm	±100ppm		
		-20 to 70°C	±20ppm	±100ppm		
		-30 to 80°C	±25ppm	±100ppm		

Note. For any other frequencies / specification please contact our sales office.

Outline in mm - Tape

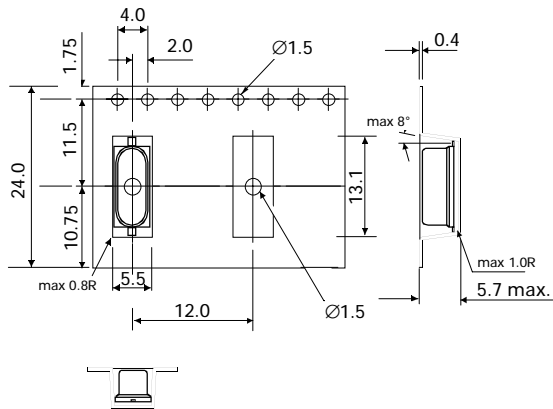

Outline in mm - Reel

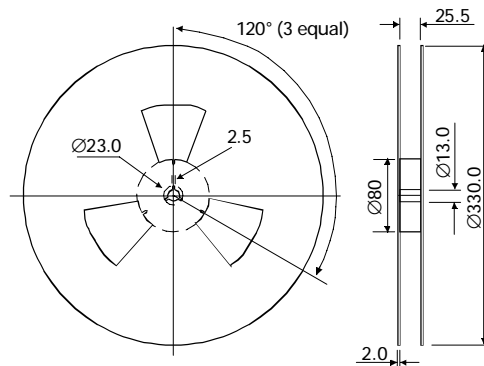

X-ON Electronics

Largest Supplier of Electrical and Electronic Components

Click to view similar products for [Crystals](#) category:

Click to view products by [IQD](#) manufacturer:

Other Similar products are found below :

[CS325S24000000ABJT](#) [718-13.2-1](#) [MC405 32.0000K-R3:PURE SN](#) [FC-135R 32.7680KF-A3](#) [7A-40.000MAAE-T](#) [7B-27.000MBBK-T](#)
[FL2000085](#) [9B-15.360MBBK-B](#) [9C-7.680MBBK-T](#) [ASH7K-32.768KHZ](#) [AT-41.600MAGQ-T](#) [BTD1062E05A-513](#) [LFX TAL066198Cutt](#)
[9C-14.31818MBBK-T](#) [FA-238 50.0000MB30X-K3](#) [FC-12M 32.7680KA-AC3](#) [SSPT7F-9PF20-R](#) [FX325BS-38.88EEM1201](#)
[LFX TAL065253Cutt](#) [LFX TAL066431Cutt](#) [XT9S20ANA14M7456](#) [XT9SNLANA16M](#) [646G-24-2](#) [7A-24.576MBBK-T](#) [7B-30.000MBBK-T](#)
[WX26-32.768K-6PF](#) [9B-14.31818MBBK-B](#) [CD1AM](#) [7B-25.000MAAE-T](#) [7A-14.31818MBBK-T](#) [6504-202-1501](#) [6526-202-1501](#) [FA-118T](#)
[27.1200MB50P-K0](#) [FC-135R 32.7680KA-A3](#) [ABM12-104-37.400MHZT](#) [ABLS-10.000MHZ-D3W-T](#) [BTJ112E01E-513](#) [BTJ722K01C-7067](#)
[BTL-20-513](#) [TSX-3225 24.0000MF15X-AC](#) [TSX-3225 16.0000MF18X-AC](#) [BTJ120E02C](#) [BTL-12-513](#) [7A-10.000MBBK-T](#) [7A-](#)
[11.0592MBBK-T](#) [ABM12-103-24.000MHZT](#) [CS325S25000000ABJT](#) [ABM3B-25.000MHZ-B2-X-T](#) [FC-135 32.7680KA-A5](#) [FX0800015](#)