

# EX-L200 SERIES

**Related Information**

■ General terms and conditions..... F-7

■ Sensor selection guide ..... P.211~

■ Glossary of terms / General precautions .P.1455~ / P.1458~

■ About laser beam..... P.1499~

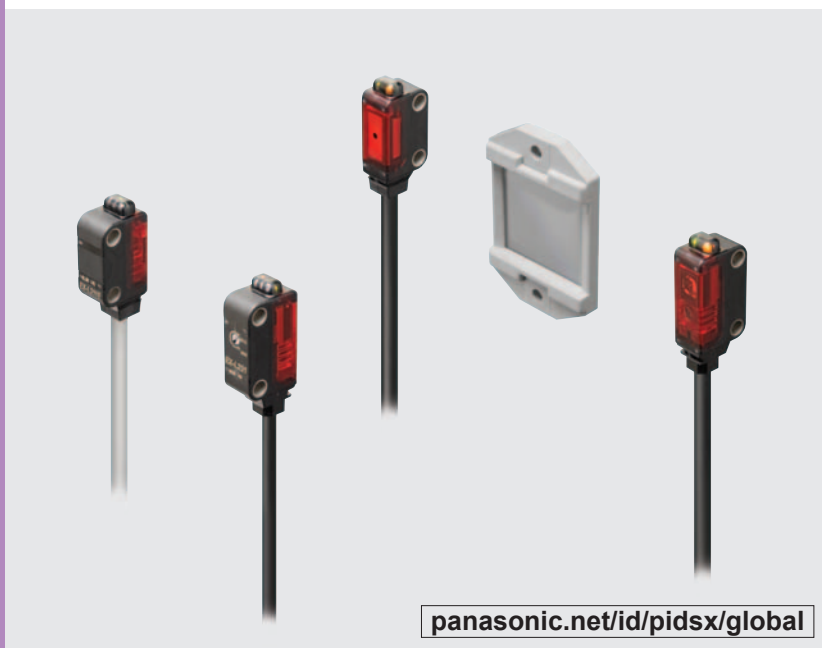
[panasonic.net/id/pidsx/global](http://panasonic.net/id/pidsx/global)Conforming to  
EMC DirectiveConforming to  
FDA regulations

This product is classified as a Class 1 Laser Product in IEC / JIS standards and in FDA\* regulations. Do not look at the laser beam through optical system such as a lens.

\*This product complies with 21 CFR 1040.10 and 1040.11 Laser Notice No. 50, dated June 24, 2007, issued by CDRH (Center for Devices and Radiological Health) under the FDA (Food and Drug Administration).

PNP output  
type availableInterference  
prevention

## Introducing ultra-compact amplifier built-in laser sensor

### Ultra-compact

Due to the customized IC and optical design, high precision detection is fulfilled with directivity and visibility achievable only by laser. The laser adopted is Class 1 (IEC / JIS / FDA) laser that is safe to use, so that there is no need to separate the areas of sensor usage.

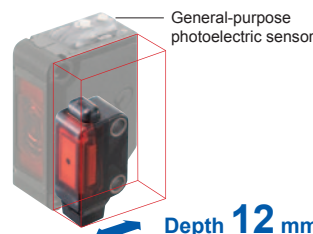

Depth **12 mm 0.472 in**  
W8.2 × H23.4 × D12 mm  
W0.323 × H0.921 × D0.472 in  
(Thru-beam type)

### THRU-BEAM TYPE

#### Minute object detection type **EX-L211**

Spread the beam and lower its density, thus even a minute object can be detected with a small change in the light received intensity. Spot size: 6 × 4 mm **0.236 × 0.157 in** approx. (Visual reference value at a sensing distance of 1 m **3.281 ft**)

#### Long sensing range type **EX-L212**

A long range detection of 3 m **9.843 ft** is achieved. High precision detection with minimum beam spread is possible even in a long range. Spot size: 8 × 5.5 mm **0.315 × 0.217 in** approx. (Visual reference value at a sensing distance of 1 m **3.281 ft**)

### REFLECTIVE TYPE

#### Long sensing range type **EX-L291**

Achieving ease of installation and 4 m **13.123 ft** long sensing range. Spot size: 6 × 4 mm **0.236 × 0.157 in** approx. (Visual reference value at a sensing distance of 1 m **3.281 ft**)

### SPOT REFLECTIVE TYPE

#### Minute object detection type **EX-L221**

Highly precise sensing with minimum 0.01 mm **0.0004 in** diameter. Many applications are possible due to the 300 mm **11.811 in** long sensing range. Spot size:  $\varnothing$ 1 mm  **$\varnothing$ 0.039 in** (Visual reference value at a sensing distance of 300 mm **11.811 in**)

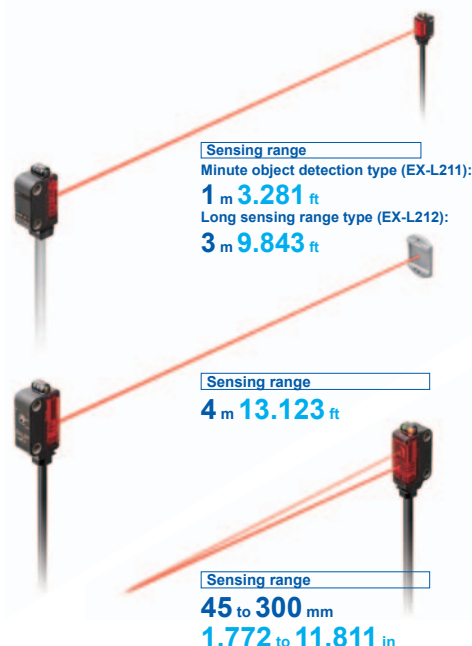
**Sensing range**

Minute object detection type (EX-L211):

**1 m 3.281 ft**

Long sensing range type (EX-L212):

**3 m 9.843 ft****Sensing range****4 m 13.123 ft****Sensing range****45 to 300 mm****1.772 to 11.811 in**Selection  
GuideAmplifier  
Built-inAmplifier-  
separated

HG-C

EX-L200

FIBER  
SENSORSLASER  
SENSORSPHOTOELECTRIC  
SENSORSMICRO  
PHOTOELECTRIC  
SENSORSAREA  
SENSORSLIGHT CURTAINS /  
SAFETY  
COMPONENTSPRESSURE /  
FLOW  
SENSORSINDUCTIVE  
PROXIMITY  
SENSORSPARTICULAR  
USE SENSORSSENSOR  
OPTIONSSIMPLE  
WIRE-  
SAVING  
UNITSWIRE-  
SAVING  
SYSTEMSMEASUREMENT  
SENSORSSTATIC ELECTRICITY  
PREVENTION  
DEVICESLASER  
MARKERS

PLC

HUMAN MACHINE  
INTERFACESENERGY CONSUMPTION  
VISUALIZATION  
COMPONENTS

FA COMPONENTS

MACHINE VISION  
SYSTEMSUV CURING  
SYSTEMS

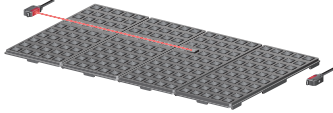
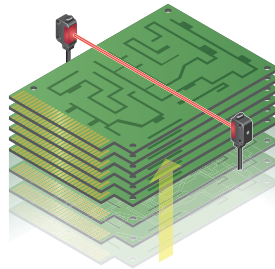
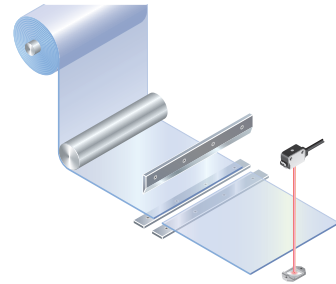
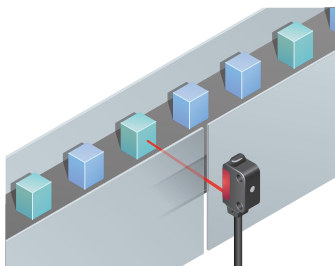
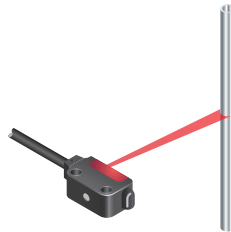
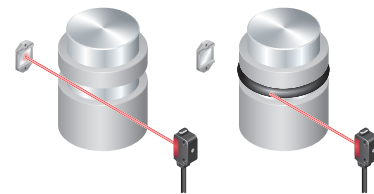
**APPLICATIONS****Detecting ICs that are out of position in multiple palettes****Confirming arrival of substrate****Determining cutting position of sheet****Sensing unevenly-colored workpieces****Sensing glossy or curved-surface workpiece, such as metallic pipes****Detecting O-ring****CONVERGENT REFLECTIVE TYPE****Spot type****EX-L261**

Highly precise sensing with minimum 0.01 mm **0.0004 in** diameter. Not affected by the background, and able to reliably sense unevenly-colored workpieces.

Spot size:  $\varnothing 1$  mm  **$\varnothing 0.039$  in** (Visual reference value at a sensing distance of 50 mm **1.969 in**)

**Line spot type****EX-L262**

Able to sense thin, glossy or curved-surface workpieces due to line beam.

Spot size:  $5 \times 1$  mm  **$0.197 \times 0.039$  in** approx. (Visual reference value at a sensing distance of 50 mm **1.969 in**)

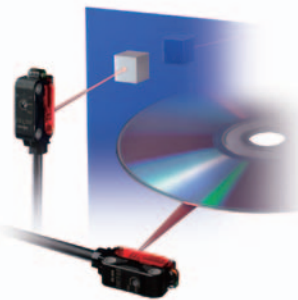
**Sensing range****Spot type (EX-L261):**

**20 mm to 50 mm**  
**0.787 in to 1.969 in**

**Sensing range****Line spot type (EX-L262):**

**20 mm to 70 mm**  
**0.787 in to 2.756 in**

FIBER  
SENSORSLASER  
SENSORSPHOTOELECTRIC  
SENSORSMICRO  
PHOTOELECTRIC  
SENSORSAREA  
SENSORSLIGHT CURTAINS/  
SAFETY  
COMPONENTSPRESSURE /  
FLOW  
SENSORSINDUCTIVE  
PROXIMITY  
SENSORSPARTICULAR  
USE SENSORSSENSOR  
OPTIONSSIMPLE  
WIRE-SAVING  
UNITSWIRE-SAVING  
SYSTEMSMEASUREMENT  
SENSORSSTATIC ELECTRICITY  
PREVENTION  
DEVICESLASER  
MARKERS

PLC

HUMAN MACHINE  
INTERFACESENERGY CONSUMPTION  
VISUALIZATION  
COMPONENTS

FA COMPONENTS

MACHINE VISION  
SYSTEMSUV CURING  
SYSTEMSSelection  
GuideAmplifier  
Built-in  
Amplifier-  
separated**HG-C****EX-L200**

- FIBER SENSORS
- LASER SENSORS
- PHOTOELECTRIC SENSORS
- MICRO PHOTOELECTRIC SENSORS
- AREA SENSORS
- LIGHT CURTAINS / SAFETY COMPONENTS
- PRESSURE / FLOW SENSORS
- INDUCTIVE PROXIMITY SENSORS
- PARTICULAR USE SENSORS
- SENSOR OPTIONS
- SIMPLE WIRE-SAVING UNITS
- WIRE-SAVING SYSTEMS
- MEASUREMENT SENSORS
- STATIC ELECTRICITY PREVENTION DEVICES
- LASER MARKERS
- PLC
- HUMAN MACHINE INTERFACES
- ENERGY CONSUMPTION VISUALIZATION COMPONENTS
- FA COMPONENTS
- MACHINE VISION SYSTEMS
- UV CURING SYSTEMS

- Selection Guide
- Amplifier Built-in
- Amplifier-separated
- HG-C
- EX-L200

**HIGH PRECISION**

**Highly accurate detection** **EX-L211/L221**

**Suitable for positioning and minute object detection**

A repeatability of 0.02 mm **0.0008 in** or less at a range of from 100 to 200 mm **3.937 to 7.874 in** makes this type best suitable for positioning applications (**EX-L221**). Moreover, it boasts a top-class detection precision in the compact laser sensor category with the gold wire of  $\varnothing 0.01$  mm  **$\varnothing 0.0004$  in**.

Model No. (Minute object detection type)	Minimum sensing object (Typical)	Repeatability (Typical)
<b>EX-L211</b> (Thru-beam type)	$\varnothing 0.3$ mm <b><math>\varnothing 0.012</math> in</b>	0.01 mm <b>0.0004 in</b> or less
<b>EX-L221</b> (Spot reflective type)	$\varnothing 0.01$ mm <b><math>\varnothing 0.0004</math> in</b>	0.02 mm <b>0.0008 in</b> or less

\* Typical values when the sensitivity adjuster is optimally adjusted.

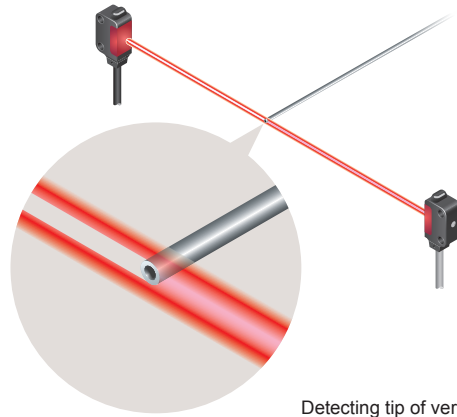

Detecting tip of very thin pipe

**Dependable technology yields high precision**

**Incorporating a high-precision aspheric glass lens**

Light aberrations are reduced and a high definition laser spot is possible by incorporating a molded aspheric glass lens.

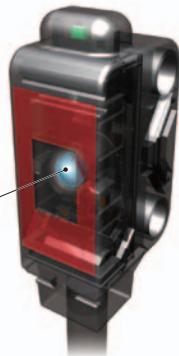

The secret to high precision  
**Molded aspheric glass lenses**

**Small receiver aperture for precision detection**

**EX-L211/L212**

Errant beams are eliminated by the  $\varnothing 0.5$  mm  **$\varnothing 0.020$  in** receiver aperture. Only beams entering the aperture are used, making for high-precision sensing.



The secret to high precision  
 $\varnothing 0.5$  mm  
 **$\varnothing 0.020$  in** slit

**Stable convergent distance sensing**

**For sensing when background object presents**

Due to convergent distance sensing, the background has very little effect, enabling stable sensing. Sensitivity adjuster allows you to adjust sensitivity to avoid sensing background objects when the distance between the workpiece and background objects is small.



Sensitivity adjuster

**For sensing thin, glossy or curved-surface workpieces (Line spot type EX-L262)**

**EX-L261/L262**

Able to sense glossy or curved-surface workpieces, such as PCB and metallic pipes, due to a wide line laser beam.

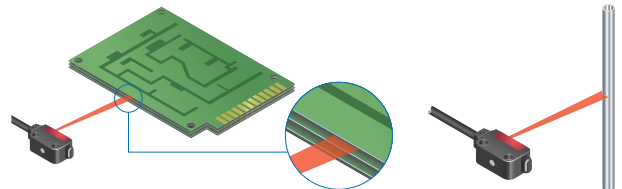

**For sensing unevenly-colored workpieces**

Able to reliably sense unevenly-colored workpieces.

**EASY ALIGNMENT****Easy beam-axis alignment****EX-L211/L212****Visual positioning is easy due to silhouetting a sensing object against a receiver.**

Visually confirm the optimal receiver position, adjusting the beam axis by aligning the objects while watching the red spot on the beam alignment screen. The diagram on the right shows an example with the lead of a mechanical pencil being detected through visual adjustment.

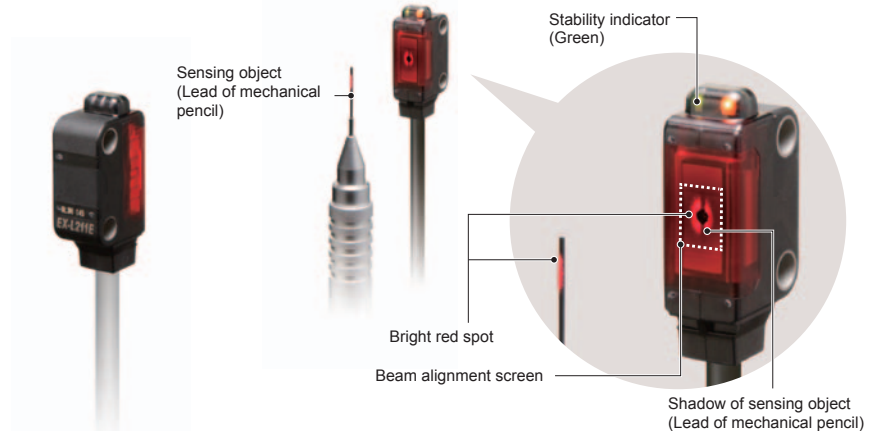
**EASY SETTING****Same mounting pitch as ultra-compact photoelectric sensor**

**EX-L200** series has the same mounting pitch as ultra-compact photoelectric sensor **EX-20** series so that the time taken in designing is saved.

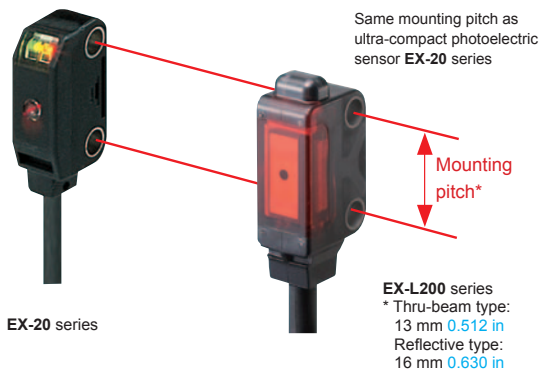
**ENVIRONMENTAL RESISTANCE****Strong against water and dust with protection structure IP67**

The sensor can be used even in environment where water or dust present because of its protection structure IP67.

**EASY TO USE****M3 screw used for secure tightening**

The mounting holes have metal sleeves inserted to prevent damage to the sensor due to over tightening of the screws. (Tightening torque: 0.5 N·m)

**Conductor thickness 1.5 times increased to make wiring easier**

The lead wire conductor's thickness is increased to 0.15 mm<sup>2</sup> from 0.1 mm<sup>2</sup> of the conventional ultra-compact photoelectric sensor. This makes it easier to perform crimping work on the cables for better workability. In addition, the tensile strength of the crimping area has become stronger.

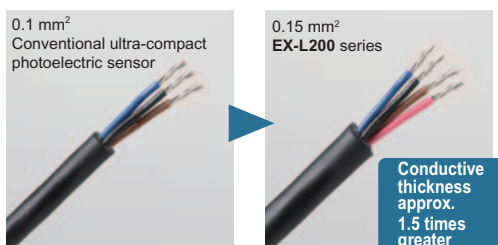
**Sensitivity adjuster (excluding EX-L212□)**

A sensitivity adjuster of world smallest size is incorporated to offer strong performance in minute detection or high precision detection.

**Low current consumption**

The laser light source contributes to low current consumption, as it is approx. 5 mA lower than a LED light source.

**Switchable output operation**

The output operation switching input enables the switching of Light-ON or Dark-ON in one unit. This prevents ordering mistake and reduces the maintenance of spare parts.

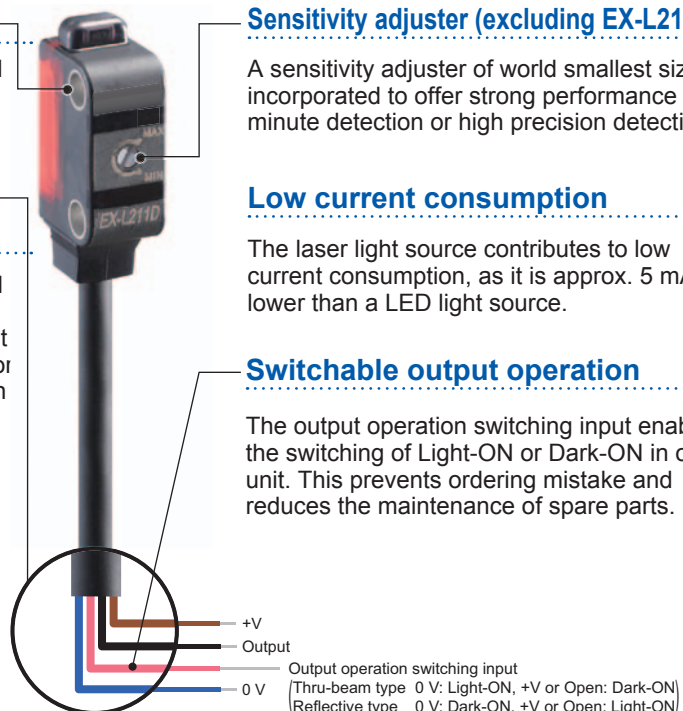

FIBER SENSORS

LASER SENSORS

PHOTOELECTRIC SENSORS

MICRO PHOTOELECTRIC SENSORS

AREA SENSORS

LIGHT CURTAINS / SAFETY COMPONENTS

PRESSURE / FLOW SENSORS

INDUCTIVE PROXIMITY SENSORS

PARTICULAR USE SENSORS

SENSOR OPTIONS

SIMPLE WIRE-SAVING UNITS

WIRE-SAVING SYSTEMS

MEASUREMENT SENSORS

STATIC ELECTRICITY PREVENTION DEVICES

LASER MARKERS

PLC

HUMAN MACHINE INTERFACES

ENERGY CONSUMPTION VISUALIZATION COMPONENTS

FA COMPONENTS

MACHINE VISION SYSTEMS

UV CURING SYSTEMS

Selection Guide

Amplifier Built-in Amplifier-separated

**HG-C****EX-L200**

**ORDER GUIDE**

FIBER SENSORS

LASER SENSORS

PHOTOELECTRIC SENSORS

MICRO PHOTOELECTRIC SENSORS

AREA SENSORS

LIGHT CURTAINS / SAFETY COMPONENTS

PRESSURE / FLOW SENSORS

INDUCTIVE PROXIMITY SENSORS

PARTICULAR USE SENSORS

SENSOR OPTIONS

SIMPLE WIRE-SAVING UNITS

WIRE-SAVING SYSTEMS

MEASUREMENT SENSORS

STATIC ELECTRICITY PREVENTION DEVICES

LASER MARKERS

PLC

HUMAN MACHINE INTERFACES

ENERGY CONSUMPTION VISUALIZATION COMPONENTS

FA COMPONENTS

MACHINE VISION SYSTEMS

UV CURING SYSTEMS

Type		Appearance	Sensing range	Model No.		Emission spot size (Typical)	Sensitivity adjuster
				NPN output	PNP output		
Thru-beam	Minute object detection		1 m 3.281 ft	EX-L211	EX-L211-P	Approx. 6 × 4 mm 0.236 × 0.157 in (at a sensing distance of 1 m 3.281 ft)	Incorporated
	Long sensing range		3 m 9.843 ft	EX-L212	EX-L212-P	Approx. 8 × 5.5 mm 0.315 × 0.217 in (at a sensing distance of 1 m 3.281 ft)	—
Retroreflective	Long sensing range		4 m 13.123 ft (Note 2)	EX-L291	EX-L291-P	Approx. 6 × 4 mm 0.236 × 0.157 in (at a sensing distance of 1 m 3.281 ft)	Incorporated
Spot reflective	Minute object detection		45 to 300 mm 1.772 to 11.811 in	EX-L221	EX-L221-P	ø1 mm ø0.039 in or less (at a sensing distance of 300 mm 11.811 in)	Incorporated
Convergent reflective	Spot		20 to 50 mm 0.787 to 1.969 in (Note 5) (Convergent point: 22 mm 0.866 in)	EX-L261	EX-L261-P	ø1 mm ø0.039 in or less (at a sensing distance of 50 mm 1.969 in)	Incorporated
	Line spot		20 to 70 mm 0.787 to 2.756 in (Note 5) (Convergent point: 22 mm 0.866 in)	EX-L262	EX-L262-P	Approx. 5 × 1 mm 0.197 × 0.039 in (at a sensing distance of 50 mm 1.969 in)	Incorporated

Notes: 1) The model No. with "E" shown on the label affixed to the thru-beam type sensor is the emitter, "D" shown on the label is the receiver.  
 2) The sensing range is the value for RF-330 reflector. The sensing range represents the actual sensing range of the sensor. The sensing ranges itemized in "A" of the table below may vary depending on the shape of sensing object. Be sure to check the operation with the actual sensing object.

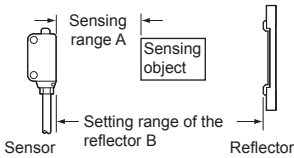

	RF-330 (Accessory)	With PF-EXL2-1 polarizing filters (Note 3)	RF-210 (Optional)	With PF-EXL2-1 polarizing filters (Note 3)
A	0 to 4 m 0 to 13.123 ft	0 to 4 m 0 to 13.123 ft	0 to 1.8 m 0 to 5.906 ft	0 to 1.2 m 0 to 3.937 ft
B	0.2 to 4 m 0.656 to 13.123 ft	0.4 to 4 m 1.312 to 13.123 ft (Note 4)	0.16 to 1.8 m 0.525 to 5.906 ft	0.25 to 1.2 m 0.820 to 3.937 ft (Note 4)

3) Refer to "OPTIONS (p.233)" for the polarizing filter PF-EXL2-1 and the reflector RF-210.  
 4) When positioning the reflector nearby, the angular characteristic become more narrow. Adjust the angle of a sensor or reflector.

5) The sensing range is specified for white non-glossy paper (100 × 100 mm 3.937 × 3.937 in) as the object.

**M8 pigtailed type and 5 m 16.404 ft cable length type**

M8 pigtailed type and 5 m 16.404 ft cable length type (standard: 2 m 6.562 ft) are also available.

When ordering these types, suffix "J" for the M8 pigtailed type, "C5" for the 5 m 16.404 ft cable length type to the model No.

Please order the mating cable for the M8 pigtailed type separately.

(e.g.) M8 pigtailed type of EX-L211-P is "EX-L211-P-J"

5 m 16.404 ft cable length type of EX-L211-P is "EX-L211-P-C5"

• **Mating cable** (2 cables are required for the thru-beam type.)

Type	Model No.	Cable length
Straight	CN-24A-C2	2 m 6.562 ft
	CN-24A-C5	5 m 16.404 ft
Elbow	CN-24AL-C2	2 m 6.562 ft
	CN-24AL-C5	5 m 16.404 ft

**Mating cable**

- CN-24A-C2
- CN-24A-C5
- CN-24AL-C2
- CN-24AL-C5

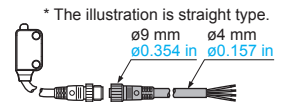

**Package without reflector**

Retroreflective type is also available without the reflector.

Type	Model No.	
	NPN output	PNP output
Retroreflective type	EX-L291-Y	EX-L291-P-Y
M8 pigtailed type	EX-L291-J-Y	EX-L291-P-J-Y
5 m 16.404 ft cable length type	EX-L291-C5-Y	EX-L291-P-C5-Y

**Accessories**

- MS-EXL2-2 (Mounting plate for thru-beam type): 1 pc.
- MS-EXL2-3 (Mounting plate for retroreflective / spot reflective / convergent reflective type): 1 pc.
- RF-330 (Reflector): 1 pc.

Selection Guide

Amplifier Built-in

Amplifier-separated

HG-C

EX-L200

## SPECIFICATIONS

Item	Model No.	Type	Thru-beam		Retroreflective	Spot reflective	Convergent reflective	
			Minute object detection	Long sensing range	Long sensing range	Minute object detection	Spot	Line spot
			NPN output	<b>EX-L211</b>	<b>EX-L212</b>	<b>EX-L291</b>	<b>EX-L221</b>	<b>EX-L261</b>
		PNP output	<b>EX-L211-P</b>	<b>EX-L212-P</b>	<b>EX-L291-P</b>	<b>EX-L221-P</b>	<b>EX-L261-P</b>	<b>EX-L262-P</b>
Sensing range			1 m <b>3.281 ft</b>	3 m <b>9.843 ft</b>	4 m <b>13.123 ft</b> (Note 2)	45 to 300 mm <b>1.772 to 11.811 in</b> (Note 3)	20 to 50 mm <b>0.787 to 1.969 in</b> (Convergent point: 22 mm <b>0.866 in</b> ) (Note 3)	20 to 70 mm <b>0.787 to 2.756 in</b> (Convergent point: 22 mm <b>0.866 in</b> ) (Note 3)
Emission spot size (Typical)			Approx. 6 × 4 mm <b>0.236 × 0.157 in</b> (vertical × horizontal) (at a sensing distance of 1 m)	Approx. 8 × 5.5 mm <b>0.315 × 0.217 in</b> (vertical × horizontal) (at a sensing distance of 1 m) (Note 4)	Approx. 6 × 4 mm <b>0.236 × 0.157 in</b> (vertical × horizontal) (at a sensing distance of 1 m) (Note 4)	ø1 mm <b>ø0.039 in</b> or less (at a sensing distance of 300 mm)	ø1 mm <b>ø0.039 in</b> (at a sensing distance of 50 mm)	Approx. 5 × 1 mm <b>0.197 × 0.039 in</b> (vertical × horizontal) (at a sensing distance of 50 mm)
Sensing object			Opaque object of ø2 mm <b>ø0.079 in</b> or more	Opaque object of ø3 mm <b>ø0.118 in</b> or more	Opaque, translucent object of ø25 mm <b>ø0.984 in</b> or more	Opaque, translucent or transparent object (Note 7)		
Minimum sensing object (Typical) (Note 5)			Opaque object of ø0.3 mm <b>ø0.012 in</b>			Gold wire of ø0.01 mm <b>ø0.0004 in</b>		
Hysteresis						20 % or less of operation distance		
Repeatability			Perpendicular to sensing axis: 0.05 mm <b>0.0020 in</b> or less			Perpendicular to sensing axis: 0.2 mm <b>0.0080 in</b> or less		
Repeatability (Typical) (perpendicular to sensing axis) (Note 5)			0.01 mm <b>0.0004 in</b> or less (all area)			0.02 mm <b>0.0008 in</b> or less (at 100 to 200 mm sensing distance)		
Supply voltage			12 to 24 V DC ±10 % Ripple P-P 10 % or less					
Current consumption			Emitter: 10 mA or less, Receiver: 10 mA or less			15 mA or less		
Output			<NPN output type> NPN open-collector transistor • Maximum sink current: 50 mA • Applied voltage: 26.4 V DC or less (between output and 0 V) • Residual voltage: 2 V or less (at 50 mA sink current) 1 V or less (at 16 mA sink current)			<PNP output type> PNP open-collector transistor • Maximum source current: 50 mA • Applied voltage: 26.4 V DC or less (between output and +V) • Residual voltage: 2 V or less (at 50 mA source current) 1 V or less (at 16 mA source current)		
Output operation			Light-ON / Dark-ON selectable by the output operation switching input					
Short-circuit protection			Incorporated (short-circuit protection / inverse polarity protection)					
Response time			0.5 ms or less					
Operation indicator			Orange LED (lights up when the output is ON) (incorporated on the receiver for thru-beam type)					
Stability indicator			Green LED (lights up under stable light received condition or stable dark condition) (incorporated on the receiver for thru-beam type)					
Power indicator			Green LED (lights up when the power is ON) (incorporated on the emitter)					
Automatic interference prevention function						Incorporated (Two sensors can be mounted close together.)		
Sensitivity adjuster			Continuously variable adjuster (receiver)			Continuously variable adjuster		
Environmental resistance	Protection		IP67 (IEC)					
	Ambient temperature		-10 to +55 °C <b>+14 to +131 °F</b> (No dew condensation or icing allowed), Storage: -30 to +70 °C <b>-22 to +158 °F</b>					
	Ambient humidity		35 to 85 % RH, Storage: 35 to 85 % RH					
	Ambient illuminance		Incandescent light: 3,000 lx at the light-receiving face					
	Voltage withstandability		1,000 V AC for one min. between all supply terminals connected together and enclosure					
	Insulation resistance		20 MΩ, or more, with 250 V DC megger between all supply terminals connected together and enclosure					
	Vibration resistance		10 to 500 Hz frequency, 1.5 mm <b>0.059 in</b> amplitude (10 G max.) in X, Y and Z directions for two hours each					
	Shock resistance		500 m/s <sup>2</sup> acceleration (50 G approx.) in X, Y and Z directions for three times each					
Emitting element			Red semiconductor laser Class 1 (IEC / JIS/ FDA) (Note 6) (Maximum output: <b>EX-L211</b> □ / <b>EX-L212</b> □ 390 μW, <b>EX-L291</b> □ 0.5 mW, <b>EX-L221</b> □ 2 mW, <b>EX-L261</b> □ 1 mW, <b>EX-L262</b> □ 1.3 mW, Peak emission wavelength: 655 nm <b>0.026 mil</b> )					
Material			Enclosure: Polybutylene terephthalate, Front cover: Acrylic, Lens: Glass					
Cable			0.15 mm <sup>2</sup> 4-core (emitter of a thru-beam type: 2-core) cable, 2 m <b>6.562 ft</b> long					
Cable extension			Extension up to total 50 m <b>164.042 ft</b> is possible with 0.3 mm <sup>2</sup> , or more, cable (thru-beam type: Total 100 m <b>328.084 ft</b> both emitter and receiver).					
Weight			Net weight: Emitter: 40 g approx., Receiver: 40 g approx., Gross weight: 90 g approx.			Net weight: 45 g approx., Gross weight: 60 g approx.		
Accessories			<b>MS-EXL2-2</b> (Metal plate): 2 pcs.		<b>RF-330</b> (Reflector): 1 pc. <b>MS-EXL2-3</b> (Metal plate): 1 pc.	<b>MS-EXL2-3</b> (Metal plate): 1 pc.		

Notes: 1) Where measurement conditions have not been specified precisely, the conditions used were an ambient temperature of +23 °C **+73.4 °F**.

2) The sensing range is the value for **RF-330** reflector. The sensing range represents the actual sensing range of the sensor. The sensing ranges itemized in "A" of the table below may vary depending on the shape of sensing object. Be sure to check the operation with the actual sensing object.

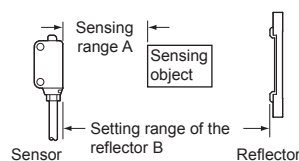

	RF-330 (Accessory)	With <b>PF-EXL2-1</b> polarizing filters *1	
		With <b>RF-210</b> (Optional)	With <b>PF-EXL2-1</b> polarizing filters *1
A	0 to 4 m <b>0 to 13.123 ft</b>	0 to 4 m <b>0 to 13.123 ft</b>	0 to 1.8 m <b>0 to 5.906 ft</b>
B	0.2 to 4 m <b>0.656 to 13.123 ft</b>	0.4 to 4 m <b>1.312 to 13.123 ft</b> *2	0.25 to 1.2 m <b>0.820 to 3.937 ft</b> *2

\*1 Refer to "OPTIONS" (P.233) for the polarizing filter **PF-EXL2-1** and the reflector **RF-210**.

\*2 When positioning the reflector nearby, the angular characteristic become more narrow. Adjust the angle of a sensor or reflector.

3) The sensing range is specified for white non-glossy paper (100 × 100 mm **3.937 × 3.937 in**) as the object.

4) **EX-L212** □: In the case sensing distance is 3 m **9.843 ft**, the emission spot size is H 17 × W 11 mm **H 0.669 × W 0.433 in** (visual reference value).

**EX-L291** □: In the case sensing distance is 4 m **13.123 ft**, the emission spot size is H 18 × W 10 mm **H 0.709 × W 0.394 in** (visual reference value).

5) Typical values when the sensitivity adjuster is optimally adjusted.

6) This product complies with 21 CFR 1040.10 and 1040.11 Laser Notice No. 50, dated June 24, 2007, issued by CDRH

(Center for Devices and Radiological Health) under the FDA (Food and Drug Administration). For details, refer to the Laser Notice No. 50.

7) Make sure to confirm detection with an actual sensor before use.

FIBER

SENSORS

LASER

SENSORS

PHOTO-

ELECTRIC

SENSORS

MICRO

PHOTO-

ELECTRIC

SENSORS

AREA

SENSORS

LIGHT

CURTAINS /

SAFETY

COMPONENTS

PRESSURE /

FLOW

SENSORS

INDUCTIVE

PROXIMITY

SENSORS

PARTICULAR

USE

SENSORS

SENSOR

OPTIONS

SIMPLE

WIRE-SAVING

UNITS

WIRE-SAVING

SYSTEMS

MEASUREMENT

SENSORS

STATIC

ELECTRICITY

PREVENTION

DEVICES

LASER

MARKERS

PLC

HUMAN

MACHINE

INTERFACES

ENERGY

CONSUMPTION

VISUALIZATION

COMPONENTS

FA

COMPONENTS

MACHINE

VISION

SYSTEMS

UV

CURING

SYSTEMS

Selection

Guide

Amplifier

Built-in

Amplifier-

separated

HG-C

EX-L200

FIBER SENSORS

LASER SENSORS

PHOTO-ELECTRIC SENSORS

MICRO PHOTO-ELECTRIC SENSORS

AREA SENSORS

LIGHT CURTAINS / SAFETY COMPONENTS

PRESSURE / FLOW SENSORS

INDUCTIVE PROXIMITY SENSORS

PARTICULAR USE SENSORS

SENSOR OPTIONS

SIMPLE WIRE-SAVING UNITS

WIRE-SAVING SYSTEMS

MEASUREMENT SENSORS

STATIC ELECTRICITY PREVENTION DEVICES

LASER MARKERS

PLC

HUMAN MACHINE INTERFACES

ENERGY CONSUMPTION VISUALIZATION COMPONENTS

FA COMPONENTS

MACHINE VISION SYSTEMS

UV CURING SYSTEMS

Selection Guide

Amplifier Built-in

Amplifier-separated

HG-C

EX-L200

**OPTIONS**

Designation	Model No.	Description
Sensor mounting bracket	<b>MS-EXL2-1</b>	Foot angled mounting bracket (The thru-beam type sensor needs two brackets.)
	<b>MS-EXL2-6</b>	Compatible bracket for thru-beam type A bracket to easily mount <b>EX-L21</b> on the 25.4 mm 1.000 in pitch sensor mounting bracket: Use with the mounting plate attached to the sensor. Two brackets are needed when used for the emitter and the receiver.
Universal sensor mounting bracket	<b>MS-EXL2-4</b>	It can adjust the height and the angle of the sensor. (The thru-beam type sensor needs two brackets.)
Polarizing filter	<b>PF-EXL2-1</b>	For retroreflective type <b>EX-L291</b> Stabilizes sensitivity of the reflective surface.
Reflector	<b>RF-210</b>	For retroreflective type <b>EX-L291</b> Sensing range: 1.8 m 5.906 in (Note)
Reflector mounting bracket	<b>MS-RF21-1</b>	Protective mounting bracket for <b>RF-210</b> It protects the reflector from damage and maintains alignment.

Note: Set the distance between the reflector and sensor to be at least 0.16 m 0.525 in. Refer to "ORDER GUIDE (p.231)" for details.

**Sensor mounting bracket**

• **MS-EXL2-1**

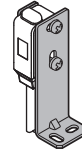

Material: Stainless steel (SUS304)  
Two M3 (length 14 mm 0.551 in) screws with washers [stainless steel (SUS304)] are attached.

• **MS-EXL2-6**

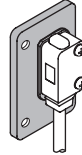

Material: Stainless steel (SUS304)  
Two M3 (length 12 mm 0.472 in) screws with washers [stainless steel (SUS)] are attached.

**Universal sensor mounting bracket**

• **MS-EXL2-4**

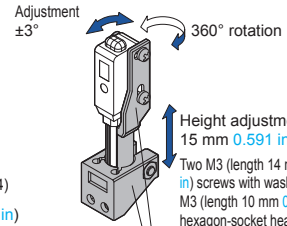

Adjustment  $\pm 3^\circ$   
360° rotation  
Height adjustment: 15 mm 0.591 in  
Two M3 (length 14 mm 0.551 in) screws with washers, one M3 (length 10 mm 0.394 in) hexagon-socket head bolt [stainless steel (SUS)], and one M3 hexagon nut [stainless steel (SUS)] are attached.  
Material: Die-cast zinc alloy

**Reflector**

• **RF-210**

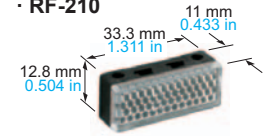

**Polarizing filter**

• **PF-EXL2-1**

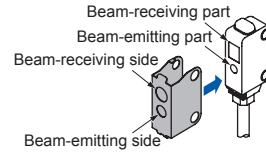

Material: Stainless steel (SUS304)

**Reflector mounting bracket**

• **MS-RF21-1**

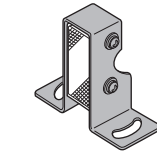

Two M3 (length 12 mm 0.472 in) screws with washers are attached.

**I/O CIRCUIT DIAGRAMS**

**NPN output type**

**I/O circuit diagrams**

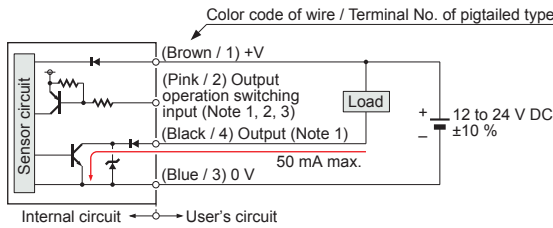

Notes: 1) The emitter of a thru-beam type does not incorporate output (black / 4) and output operation switching input (pink / 2).  
2) Be able to select either Light-ON or Dark-ON by wiring the output operation switching input (pink / 2) as shown in the following table.

Type	Light-ON	Dark-ON
Thru-beam, Retroreflective	Connect to 0 V	Connect to + V or, Open
Spot reflective / Convergent reflective	Connect to + V or, Open	Connect to 0 V

\* Insulate the output operation switching input wire (pink / 2) when leaving it open.

3) When connecting the mating cable to the pigtailed type, color code of wire is "white".

**Connector pin position (pigtailed type)**

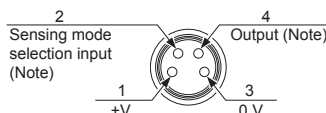

Note: The emitter of a thru-beam type does not incorporate output and output operation switching input.

**PNP output type**

**I/O circuit diagrams**

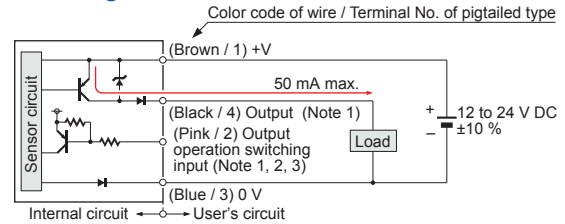

Notes: 1) The emitter of a thru-beam type does not incorporate output (black / 4) and output operation switching input (pink / 2).  
2) Be able to select either Light-ON or Dark-ON by wiring the output operation switching input (pink / 2) as shown in the following table.

Type	Light-ON	Dark-ON
Thru-beam, Retroreflective	Connect to 0 V	Connect to + V or, Open
Spot reflective / Convergent reflective	Connect to + V or, Open	Connect to 0 V

\* Insulate the output operation switching input wire (pink / 2) when leaving it open.

3) When connecting the mating cable to the pigtailed type, color code of wire is "white".

**Connector pin position (pigtailed type)**

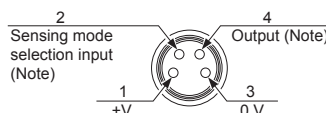

Note: The emitter of a thru-beam type does not incorporate output and output operation switching input.

**SENSING CHARACTERISTICS (TYPICAL)**

**EX-L211** Thru-beam type

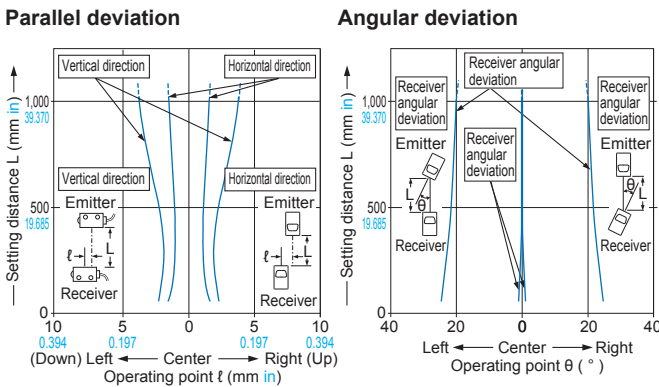

**EX-L212** Thru-beam type

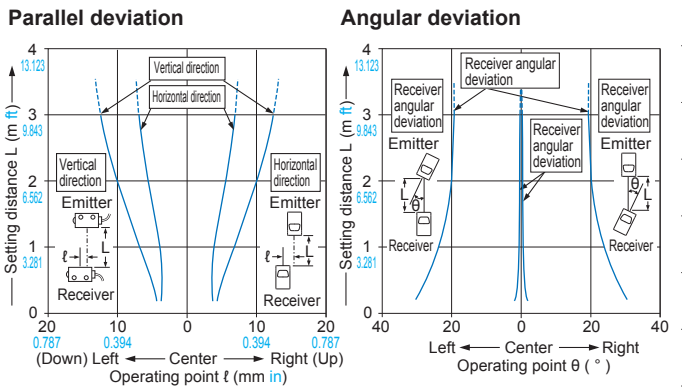

**EX-L291** Retroreflective type

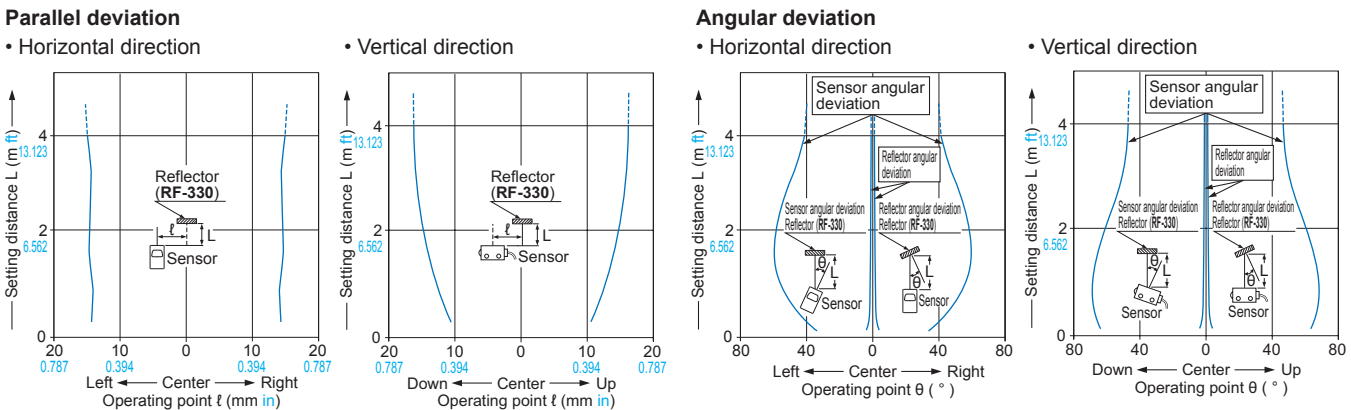

**EX-L221** Spot reflective type

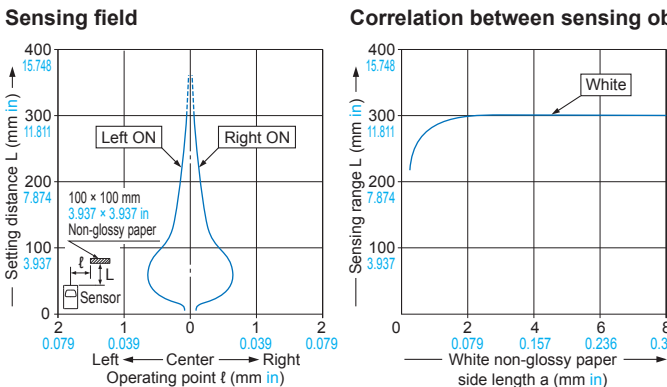

As the sensing object size becomes smaller than the standard size (white non-glossy paper 100 × 100 mm 3.937 × 3.937 in), the sensing range shortens, as shown in the left graph.  
 (For plotting the left graph, the sensitivity has been set such that a 100 × 100 mm 3.937 × 3.937 in white non-glossy paper is just detectable at a distance of 300 mm 11.811 in.)

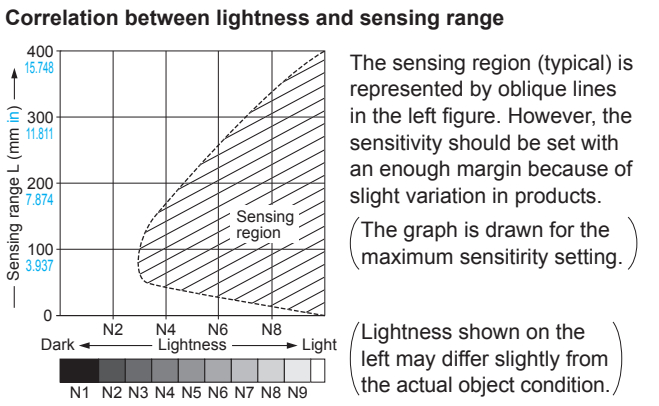

The sensing region (typical) is represented by oblique lines in the left figure. However, the sensitivity should be set with an enough margin because of slight variation in products.  
 (The graph is drawn for the maximum sensitivity setting.)  
 (Lightness shown on the left may differ slightly from the actual object condition.)

- FIBER SENSORS
- LASER SENSORS
- PHOTO-ELECTRIC SENSORS
- MICRO PHOTO-ELECTRIC SENSORS
- AREA SENSORS
- LIGHT CURTAINS / SAFETY COMPONENTS
- PRESSURE / FLOW SENSORS
- INDUCTIVE PROXIMITY SENSORS
- PARTICULAR USE SENSORS
- SENSOR OPTIONS
- WIRE-SAVING UNITS
- WIRE-SAVING SYSTEMS
- MEASUREMENT SENSORS
- STATIC ELECTRICITY PREVENTION DEVICES
- LASER MARKERS
- PLC
- HUMAN MACHINE INTERFACES
- ENERGY CONSUMPTION VISUALIZATION COMPONENTS
- FA COMPONENTS
- MACHINE VISION SYSTEMS
- UV CURING SYSTEMS
- Selection Guide
- Amplifier Built-in
- Amplifier-separated
- HG-C
- EX-L200



**SENSING CHARACTERISTICS (TYPICAL)**

**EX-L261**

Convergent reflective

**Sensing field**

• Horizontal (left and right) direction

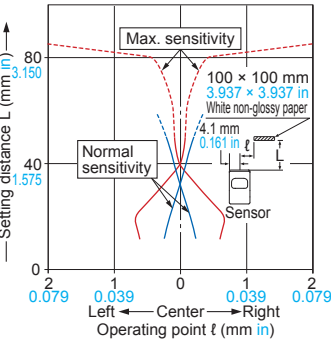

• Vertical (up and down) direction

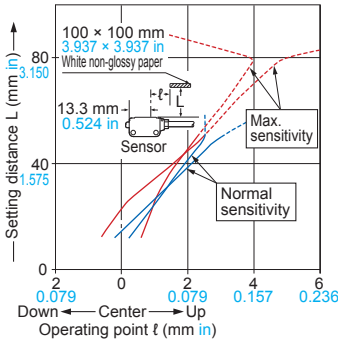

**Emitted beam**

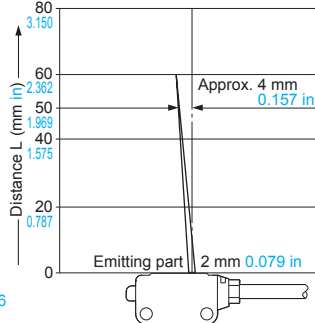

**Correlation between lightness and sensing range**

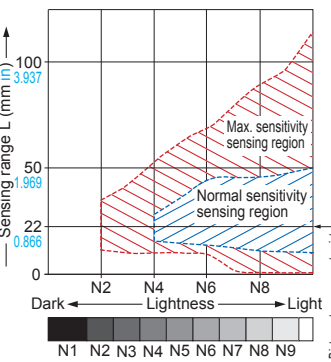

The sensing region (typical) is represented by oblique lines in the left figure. However, the sensitivity should be set with enough margin because of slight variation in products.

(Lightness shown on the left may differ slightly from the actual object condition.)

**Correlation between material and sensing range (face-to-face)**

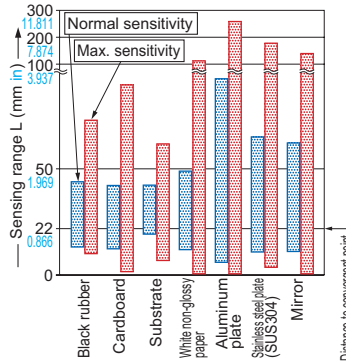

The bars in the graph indicate the sensing range (typical) for the respective material. However, there is a slight variation in the sensing range depending on the product. Further, if there is a reflective object (conveyor, etc.) in the background of the sensing object, since it affects the sensing, separate it by more than twice the sensing range shown in the left graph, or adjust the sensitivity adjuster. Make sure to confirm detection with an actual sensor.

**EX-L262**

Convergent reflective

**Sensing field**

• Horizontal (left and right) direction

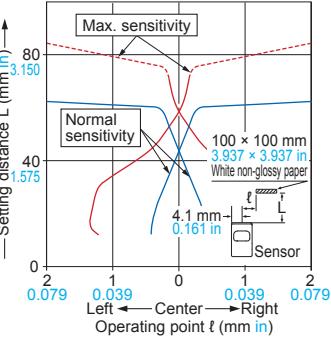

• Vertical (up and down) direction

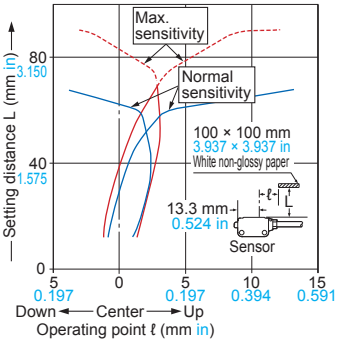

**Emitted beam**

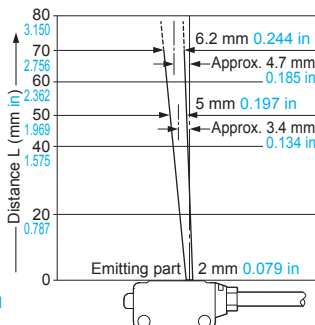

**Correlation between lightness and sensing range**

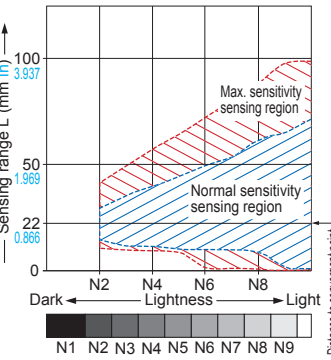

The sensing region (typical) is represented by oblique lines in the left figure. However, the sensitivity should be set with enough margin because of slight variation in products.

(Lightness shown on the left may differ slightly from the actual object condition.)

**Correlation between material and sensing range (face-to-face)**

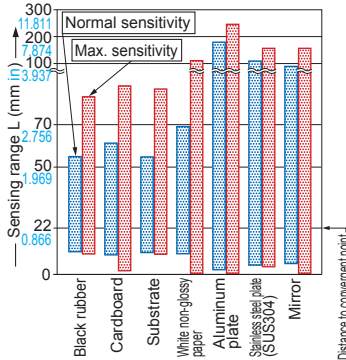

The bars in the graph indicate the sensing range (typical) for the respective material. However, there is a slight variation in the sensing range depending on the product. Further, if there is a reflective object (conveyor, etc.) in the background of the sensing object, since it affects the sensing, separate it by more than twice the sensing range shown in the left graph, or adjust the sensitivity adjuster. Make sure to confirm detection with an actual sensor.

- FIBER SENSORS
- LASER SENSORS
- PHOTO-ELECTRIC SENSORS
- MICRO PHOTO-ELECTRIC SENSORS
- AREA SENSORS
- LIGHT CURTAINS/SAFETY COMPONENTS
- PRESSURE / FLOW SENSORS
- INDUCTIVE PROXIMITY SENSORS
- PARTICULAR USE SENSORS
- SENSOR OPTIONS
- SIMPLE WIRE-SAVING UNITS
- WIRE-SAVING SYSTEMS
- MEASUREMENT SENSORS
- STATIC ELECTRICITY PREVENTION DEVICES
- LASER MARKERS
- PLC
- HUMAN MACHINE INTERFACES
- ENERGY CONSUMPTION VISUALIZATION COMPONENTS
- FA COMPONENTS
- MACHINE VISION SYSTEMS
- UV CURING SYSTEMS
- Selection Guide
- Amplifier Built-in
- Amplifier-separated
- HG-C
- EX-L200

**PRECAUTIONS FOR PROPER USE**

Refer to p.1458~ for general precautions and p.1499~ for information about laser beam.

FIBER  
SENSORSLASER  
SENSORSPHOTO-  
ELECTRIC  
SENSORSMICRO  
PHOTO-  
ELECTRIC  
SENSORSAREA  
SENSORSLIGHT  
CURTAINS /  
SAFETY  
COMPONENTSPRESSURE /  
FLOW  
SENSORSINDUCTIVE  
PROXIMITY  
SENSORSPARTICULAR  
USE  
SENSORSSENSOR  
OPTIONSSIMPLE  
WIRE-SAVING  
UNITSWIRE-SAVING  
SYSTEMSMEASURE-  
MENT  
SENSORSSTATIC  
ELECTRICITY  
PREVENTION  
DEVICESLASER  
MARKERS

PLC

HUMAN  
MACHINE  
INTERFACESENERGY  
CONSUMPTION  
VISUALIZATION  
COMPONENTSFA  
COMPONENTSMACHINE  
VISION  
SYSTEMSUV  
CURING  
SYSTEMSSelection  
GuideAmplifier  
Built-inAmplifier-  
separated

HG-C

EX-L200

- This catalog is a guide to select a suitable product. Be sure to read the instruction manual attached to the product prior to its use.



- Never use this product as a sensing device for personnel protection.
- In case of using sensing devices for personnel protection, use products which meet laws and standards, such as OSHA, ANSI or IEC etc., for personnel protection applicable in each region or country.

**Cautions for laser beams**

- This product is classified as a Class 1 Laser Product in IEC / JIS standards and in FDA\* regulations. Do not look at the laser beam through optical system such as a lens.
- The following label is attached to the cable. Handle the product according to the instruction given on the warning label.

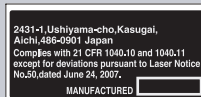

Proof label

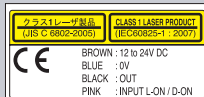

Warning label

\*This product complies with 21 CFR 1040.10 and 1040.11 Laser Notice No. 50, dated June 24, 2007, issued by CDRH (Center for Devices and Radiological Health) under the FDA (Food and Drug Administration).

**Safety standards for laser beam products**

- A laser beam can harm human being's eyes, skin, etc., because of its high energy density. IEC has classified laser products according to the degree of hazard and the stipulated safety requirements. **EX-L200** series is classified as Class 1 laser.

**Classification by IEC 60825-1**

Classification	Description
Class 1	Lasers that are safe under reasonably foreseeable conditions of operation, including the use of optical instruments for intrabeam viewing.

**Safe use of laser products**

- For the purpose of preventing users from suffering injuries by laser products, IEC 60825-1 (Safety of laser products). Kindly check the standards before use. (Refer to About laser beam.)

**Mounting**

- When mounting this sensor, use a mounting plate (**MS-EXL2-2**, **MS-EXL2-3**). Without using the mounting plate, beam misalignment may occur. Also, install the mounting plate in between the sensor and the mounting surface.
  - The tightening torque should be 0.5 N·m or less.
- Note: The mounting direction of the mounting plate is fixed. Install in a way so that the bending shape is facing the sensor side.

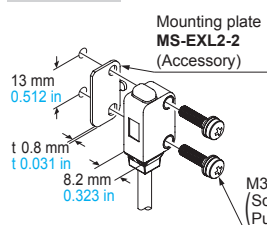
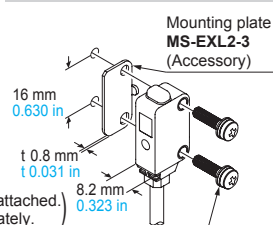
**EX-L21****EX-L291 / L221 / L261 / 262****Automatic interference prevention function**

- Spot reflective type sensor incorporate this function. Up to two sets of sensor can be mounted closely. (Thru-beam type sensor does not have this function.)

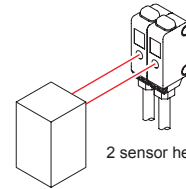

2 sensor heads can be mounted adjacently.

Note: If two spot reflective type sensor are mounted facing each other, they should be angled so as not to receive the beam from the opposing sensor or to detect its front face.

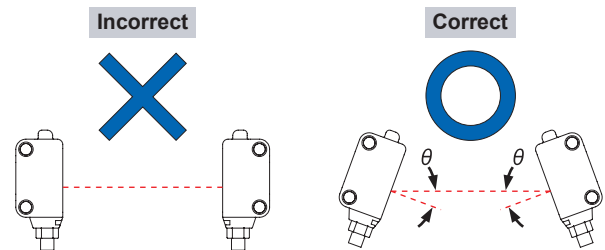
**Others**

- Do not use during the initial transient time (approx. 50ms) after the power supply is switched ON.
- In case the load and this sensor are connected to different power supplies, be sure to turn ON the power from the sensor.
- The cable may break by applying excess stress in low temperature.
- Do not allow any water, oil fingerprints, etc., which may refract light, or dust, dirt, etc., which may block light, to stick to the emitting / receiving surfaces of the sensor head. In case they are present, wipe them with a clean, soft cloth or lens paper. Do not use this sensor in places having excessive vapor, dust, etc., or where it may come in contact with corrosive gas.
- Take care that the sensor does not come in direct contact with oil, grease, organic solvents, such as, thinner etc., or strong acid, and alkaline.
- Make sure that the power is OFF while cleaning the emitting / receiving windows of the sensor head.
- This device is using a laser which has high directional quality. Therefore the beam possibly be out of alignment by the mounting condition of this device or distortion of housing etc. Make sure to adjust the beam axe alignment before use.

**DIMENSIONS (Unit: mm in)**

The CAD data in the dimensions can be downloaded from our website.

**EX-L211(-P) EX-L212(-P)** Sensor

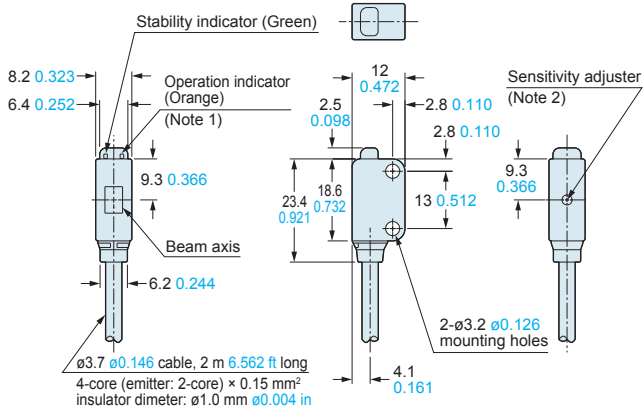

Notes: 1) It is the laser radiation indicator (green) on the emitter.  
2) It is incorporated in EX-L211(-P) only.

**EX-L211(-P)-J EX-L212(-P)-J** Sensor

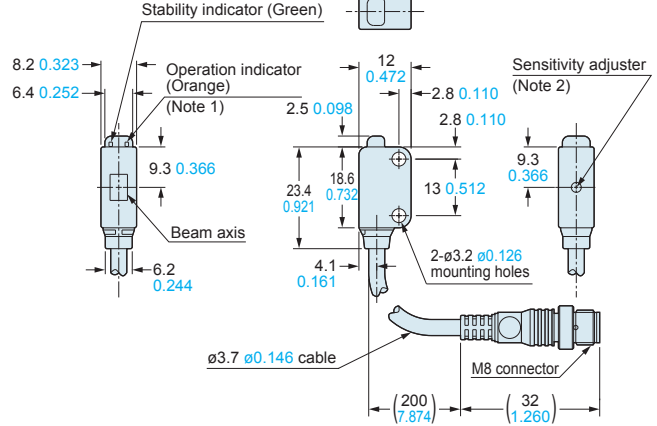

Notes: 1) It is the laser radiation indicator (green) on the emitter.  
2) It is incorporated in EX-L211(-P)-J only.

**EX-L291(-P) EX-L221(-P)** Sensor

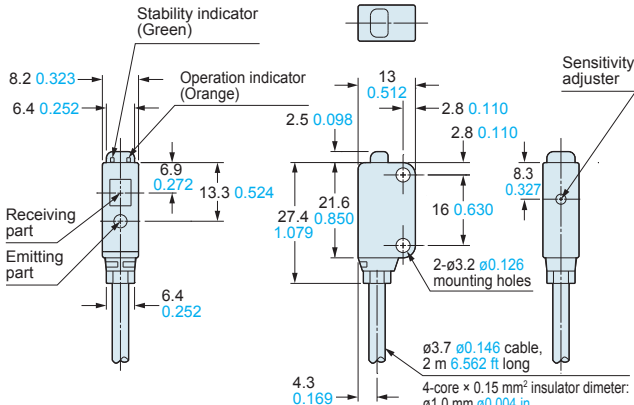

**Assembly dimensions with polarizing filter (PF-EXL2-1)**

Mounting drawing with EX-L291(-P)

**EX-L291(-P)-J EX-L221(-P)-J** Sensor

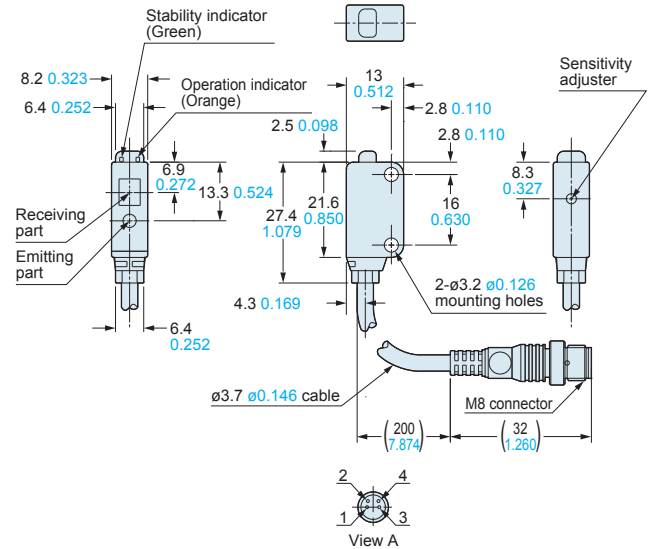

**EX-L261(-P) EX-L262(-P)** Sensor

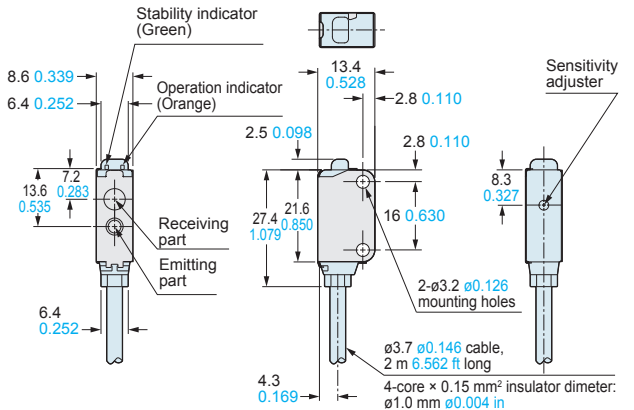

**EX-L261(-P) EX-L262(-P)** Sensor

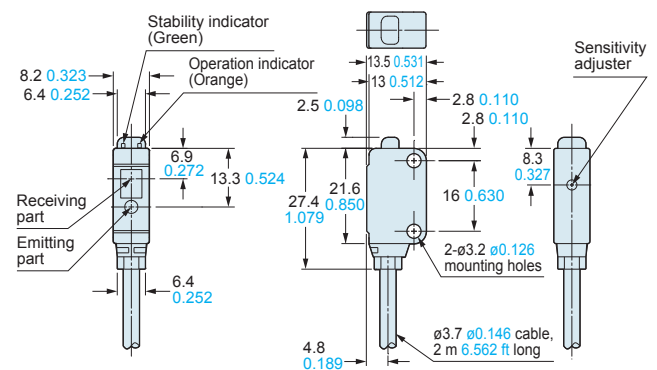

FIBER SENSORS

LASER SENSORS

PHOTO-ELECTRIC SENSORS

MICRO PHOTO-ELECTRIC SENSORS

AREA SENSORS

LIGHT CURTAINS/SAFETY COMPONENTS

PRESSURE/FLOW SENSORS

INDUCTIVE PROXIMITY SENSORS

PARTICULAR USE SENSORS

SENSOR OPTIONS

SIMPLE WIRE-SAVING UNITS

WIRE-SAVING SYSTEMS

MEASUREMENT SENSORS

STATIC ELECTRICITY PREVENTION DEVICES

LASER MARKERS

PLC

HUMAN MACHINE INTERFACES

ENERGY CONSUMPTION VISUALIZATION COMPONENTS

FA COMPONENTS

MACHINE VISION SYSTEMS

UV CURING SYSTEMS

Selection Guide

Amplifier Built-in

Amplifier-separated

HG-C

EX-L200

**DIMENSIONS (Unit: mm in)**

The CAD data in the dimensions can be downloaded from our website.

**RF-330 Reflector (Accessory for EX-L291□)**

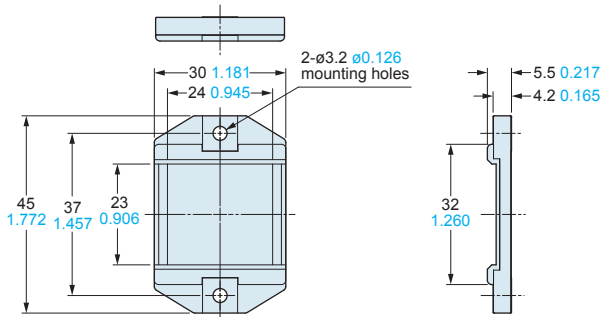

Material: Acrylic (Reflector)  
ABS (Base)

**RF-210 Reflector (Optional)**

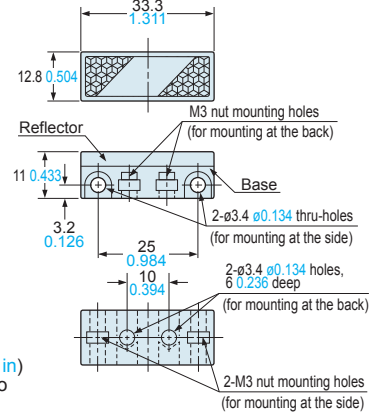

Material: Acrylic (Reflector)  
ABS (Base)  
Two M3 (length 8 mm 0.315 in) screws with washers and two nuts are attached.

**MS-RF21-1 Reflector mounting bracket for RF-210 (Optional)**

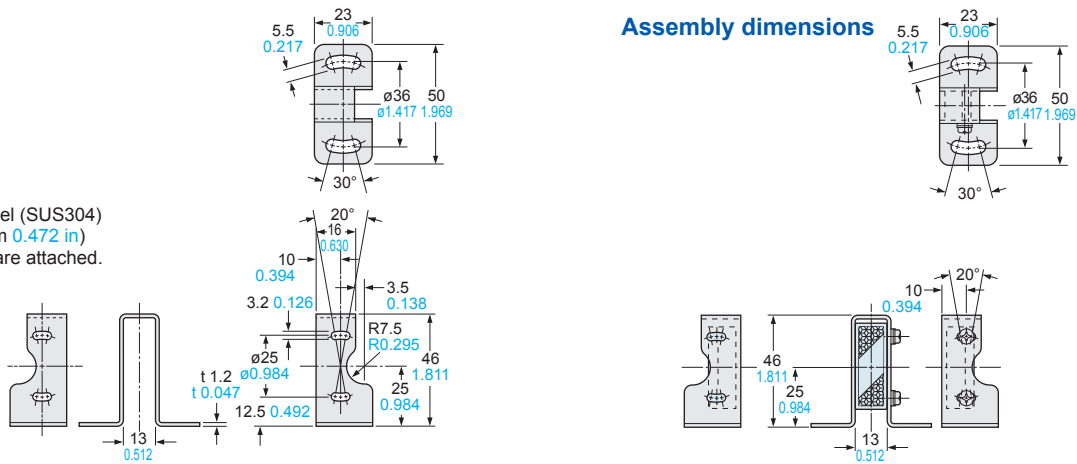

Material: Stainless steel (SUS304)  
Two M3 (length 12 mm 0.472 in) screws with washers are attached.

**MS-EXL2-1 Sensor mounting bracket (Optional)**

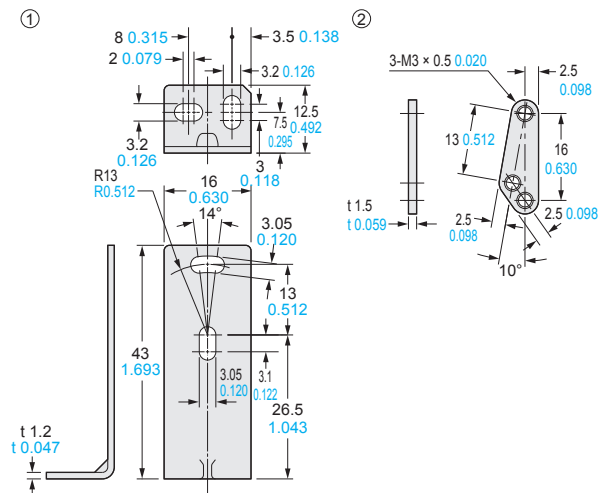

Material: Stainless steel (SUS304)  
Two M3 (length 14 mm 0.551 in) screws with washers [stainless steel (SUS304)] are attached.

**Assembly dimensions**

Mounting drawing with the receiver of EX-L211□/L212□

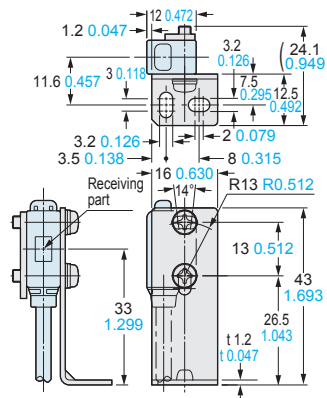

Mounting drawing with EX-L291□/L221□/L261□/L262□

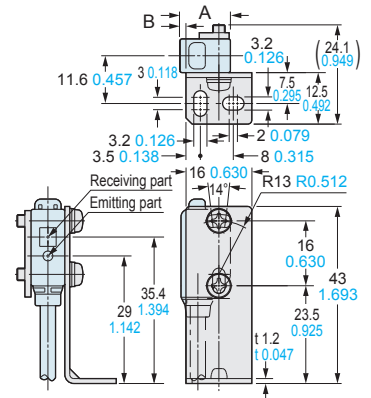

Model No.	A	B
EX-L291□ / L221□	13 0.512	2.2 0.087
EX-L261□ / L262□	13.5 0.532	2.7 0.106

- FIBER SENSORS
- LASER SENSORS
- PHOTO-ELECTRIC SENSORS
- MICRO PHOTO-ELECTRIC SENSORS
- AREA SENSORS
- LIGHT CURTAINS / SAFETY COMPONENTS
- PRESSURE / FLOW SENSORS
- INDUCTIVE PROXIMITY SENSORS
- PARTICULAR USE SENSORS
- SENSOR OPTIONS
- SIMPLE WIRE-SAVING UNITS
- WIRE-SAVING SYSTEMS
- MEASUREMENT SENSORS
- STATIC ELECTRICITY PREVENTION DEVICES
- LASER MARKERS
- PLC
- HUMAN MACHINE INTERFACES
- ENERGY CONSUMPTION VISUALIZATION COMPONENTS
- FA COMPONENTS
- MACHINE VISION SYSTEMS
- UV CURING SYSTEMS

- Selection Guide
- Amplifier Built-in
- Amplifier-separated
- HG-C
- EX-L200

**DIMENSIONS (Unit: mm in)**

The CAD data in the dimensions can be downloaded from our website.

FIBER SENSORS

LASER SENSORS

PHOTO-ELECTRIC SENSORS  
MICRO PHOTO-ELECTRIC SENSORS

AREA SENSORS

LIGHT CURTAINS/SAFETY COMPONENTS

PRESSURE/ FLOW SENSORS

INDUCTIVE PROXIMITY SENSORS

PARTICULAR USE SENSORS

SENSOR OPTIONS

SIMPLE WIRE-SAVING UNITS

WIRE-SAVING SYSTEMS

MEASUREMENT SENSORS

STATIC ELECTRICITY PREVENTION DEVICES

LASER MARKERS

PLC

HUMAN MACHINE INTERFACES

ENERGY CONSUMPTION VISUALIZATION COMPONENTS

FA COMPONENTS

MACHINE VISION SYSTEMS

UV CURING SYSTEMS

**MS-EXL2-2** Mounting plate (Accessory for EX-L211□/L212□)

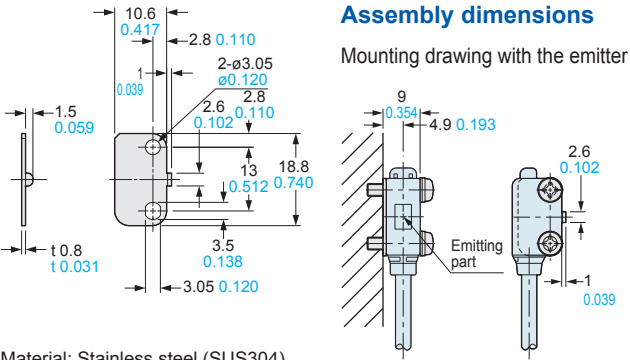

Note: Screws are not attached. Purchase separately.

\* Without using the mounting plate, beam misalignment may occur.

**MS-EXL2-3** Mounting plate (Accessory for EX-L291□/L221□/L26□)

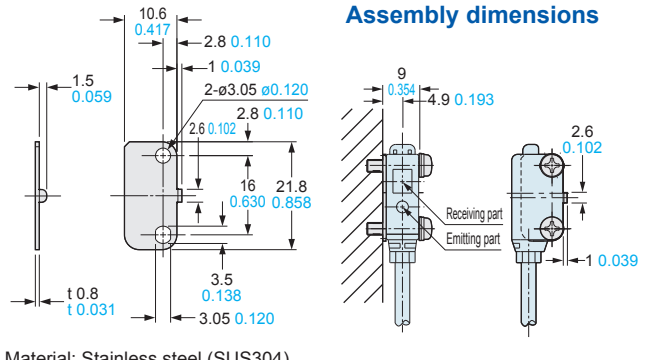

Note: Screws are not attached. Purchase separately.

\* Without using the mounting plate, beam misalignment may occur.

**MS-EXL2-4** Universal sensor mounting bracket (Optional)

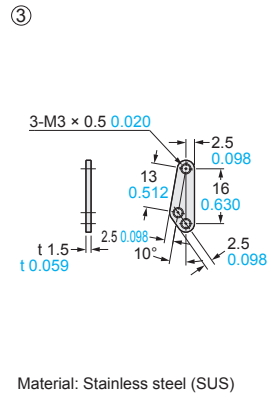
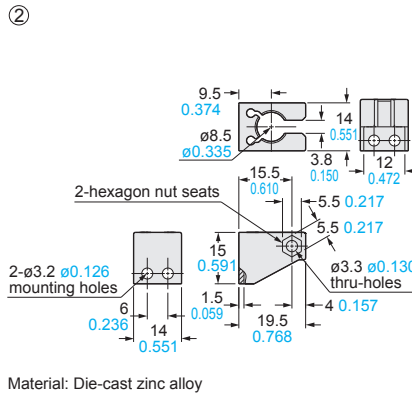
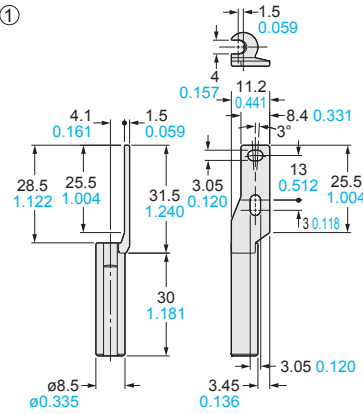

Two M3 (length 14 mm 0.551 in) screws with washers, one M3 (length 10 mm 0.394 in) hexagon socket-head bolt [stainless steel (SUS)], and one M3 hexagon nut [stainless steel (SUS)] are attached.

**Assembly dimensions**

Mounting drawing with the receiver of EX-L211□/L212□

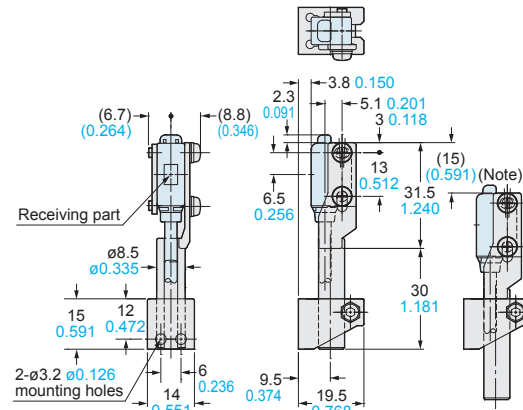

**Assembly dimensions**

Mounting drawing with EX-L291□/L221□

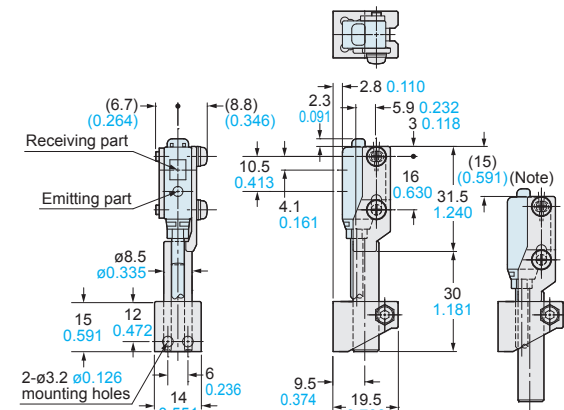

Selection Guide  
Amplifier Built-in  
Amplifier-separated

HG-C

EX-L200

## X-ON Electronics

Largest Supplier of Electrical and Electronic Components

*Click to view similar products for [panasonic](#) manufacturer:*

Other Similar products are found below :

[ECE-A1HKAR47](#) [ELC-09D151F](#) [HC2-H-DC48V-F](#) [HL2-HP-AC120V-F](#) [HL2-H-DC12V-F](#) [HL2-HP-DC12V-F](#) [HL2-HP-DC6V-F](#) [HL2-HP-DC24V-F](#) [HL2-H-DC110V-F](#) [HC4-H-DC24V](#) [HL2-HTM-DC24V-F](#) [HL2-HTM-AC24V-F](#) [HC4-H-AC24V](#) [HC4-H-AC120V](#) [HC4-H-DC12V](#) [AZH2031](#) [RP-SDMF64DA1](#) [EVM-F6SA00B55](#) [RP-SMLE08DA1](#) [ERZ-V20R391](#) [ELL-ATV681M](#) [ERZ-V05V680CB](#) [LT4H-DC24V](#) [LT4HL8-AC24V](#) [LT4HW-AC24V](#) [LT4HWT8-AC240V](#) [LT4HWT-AC240VS](#) [CY-122A-P](#) [ETQ-P5M470YFM](#) [EVAL\\_PAN1555](#) [EVQ-PAE04M](#) [EX-14B](#) [EX-22B-PN](#) [EX-31A-C5](#) [EXB-24N121JX](#) [MC-NA40-4](#) [EX-F72-PN](#) [EX-L211](#) [EYG-A121803V](#) [MFMCA0030AEB](#) [FCR-M50-AC208V](#) [FC-SFBH-20](#) [FC-SFBH-24](#) [FD-F8Y](#) [MHMA102A1C](#) [MHMD022S1S](#) [MHMD041S1S](#) [MHMD042G1T](#) [MHMD082G1T](#) [FD-S9](#)