

LH351B – 3535 Ceramic LED @85°C

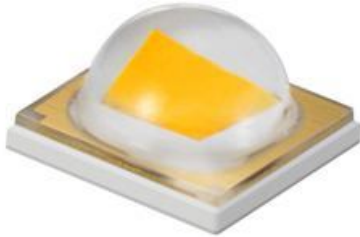

Introduction

Features

- Package : Ceramic Substrate LED Package
- View Angle: 120 °
- Precondition : JEDEC Level 2a
- Dimension : 3.5 x 3.5 x 1.93 mm
- ESD withstand Voltage : up to ± 5 KV [HBM]
- Reliability Test : IES-LM-80-08 qualified

Applications

- INDOOR LIGHTING : Spot light, Down light
- OUTDOOR LIGHTING : Street light, Security light, Tunnel light, Parking lots light
- INDUSTRIAL LIGHTING : High-bay light, Low-bay light
- CONSUMER LIGHTING : Torch light

SAMSUNG ELECTRONICS

95, Samsung2-Ro, Giheung-Gu,
Yongin-City, Gyeonggi-Do 446-711, KOREA

Contents

1. Luminous Flux Characteristics	-----	3
2. Characteristics	-----	5
3. Typical Characteristics Graph	-----	6
4. Outline Drawing & Dimension	-----	11
5. Reliability Test Items and Conditions	-----	12
6. Solder Conditions	-----	13
7. Tape & Reel	-----	14
8. Label Structure	-----	15
9. Packing Structure	-----	16
10. Precaution For Use	-----	18
11. Hazard Substance Analysis	-----	20
12. Revision History	-----	25

1. Luminous Flux Characteristics (T_j= 85°C)

Nominal CCT	Minimum CRI ¹⁾	Sorting condition Flux ²⁾ @350mA		Calculated Minimum Flux ³⁾			Product Code	BIN Structure
		Rank	Min Flux ²⁾	@700mA	@1000mA	@1500mA		
2700K	80	F3 (G3)	90 (100)	162 (177)	213 (233)	283 (309)	SPHWH2L3D30ED4W0F3	Whole
							SPHWH2L3D30ED4WPF3	Quarter
							SPHWH2L3D30ED4WMF3	M3
		G3 (H3)	100 (110)	180 (197)	237 (259)	314 (343)	SPHWH2L3D30ED4W0G3	Whole
							SPHWH2L3D30ED4WPG3	Quarter
							SPHWH2L3D30ED4WMG3	M3
		H3 (J3)	110 (120)	197 (216)	259 (284)	343 (377)	SPHWH2L3D30ED4W0H3	Whole
							SPHWH2L3D30ED4WPH3	Quarter
							SPHWH2L3D30ED4WMH3	M3
3000K	80	G3 (H3)	100 (110)	180 (197)	237 (259)	314 (343)	SPHWH2L3D30ED4V0G3	Whole
							SPHWH2L3D30ED4VPG3	Quarter
							SPHWH2L3D30ED4VMG3	M3
		H3 (J3)	110 (120)	197 (216)	259 (284)	343 (377)	SPHWH2L3D30ED4V0H3	Whole
							SPHWH2L3D30ED4VPH3	Quarter
							SPHWH2L3D30ED4VMH3	M3
3500K	80	G3 (H3)	100 (110)	180 (197)	237 (259)	314 (343)	SPHWH2L3D30ED4U0G3	Whole
							SPHWH2L3D30ED4UPG3	Quarter
							SPHWH2L3D30ED4UMG3	M3
		H3 (J3)	110 (120)	197 (216)	259 (284)	343 (377)	SPHWH2L3D30ED4U0H3	Whole
							SPHWH2L3D30ED4UPH3	Quarter
							SPHWH2L3D30ED4UMH3	M3
4000K	80	G3 (H3)	100 (110)	180 (197)	237 (259)	314 (343)	SPHWH2L3D30ED4T0G3	Whole
							SPHWH2L3D30ED4TPG3	Quarter
							SPHWH2L3D30ED4TMG3	M3
		H3 (J3)	110 (120)	197 (216)	259 (284)	343 (377)	SPHWH2L3D30ED4T0H3	Whole
							SPHWH2L3D30ED4TPH3	Quarter
							SPHWH2L3D30ED4TMH3	M3
		J3 (K3)	120 (130)	216 (234)	284 (308)	377 (408)	SPHWH2L3D30ED4T0J3	Whole
							SPHWH2L3D30ED4TPJ3	Quarter
							SPHWH2L3D30ED4TMJ3	M3

()* : Minimum luminous flux @ 25°C

Notes:

- 1) SAMSUNG ELECTRONICS maintains a tolerance of ±3.0 on CRI measurements.
- 2) SAMSUNG ELECTRONICS maintains a tolerance of ±7% on flux measurements.
- 3) Calculated flux values are for reference only.

1. Luminous Flux Characteristics (T_j= 85°C)

Nominal CCT	Minimum CRI ⁽¹⁾	Sorting condition Flux ⁽²⁾ @350mA		Calculated Minimum Flux ⁽³⁾			Product Code	BIN Structure
		Rank	Min Flux ⁽²⁾	@700mA	@1000mA	@1500mA		
4000K	70	J3 (K3)	120 (130)	216 (234)	284 (308)	377 (408)	SPHWH2L3D30CD4T0J3	Whole
							SPHWH2L3D30CD4TPJ3	Quarter
							SPHWH2L3D30CD4TMJ3	M3
		K3 (M3)	130 (140)	234 (253)	308 (333)	408 (441)	SPHWH2L3D30CD4T0K3	Whole
							SPHWH2L3D30CD4TPK3	Quarter
							SPHWH2L3D30CD4TMK3	M3
		M3 (N3)	140 (150)	253 (270)	333 (355)	441 (471)	SPHWH2L3D30CD4T0M3	Whole
							SPHWH2L3D30CD4TPM3	Quarter
							SPHWH2L3D30CD4TMM3	M3
5000K	70	J3 (K3)	120 (130)	216 (234)	284 (308)	377 (408)	SPHWH2L3D30CD4RTJ3	half
							SPHWH2L3D30CD4RTK3	half
							SPHWH2L3D30CD4RTM3	half
		K3 (M3)	130 (140)	234 (253)	308 (333)	408 (441)		
	M3 (N3)	140 (150)	253 (270)	333 (355)	441 (471)			
75	J3 (K3)	120 (130)	216 (234)	284 (308)	377 (408)	SPHWH2L3D30DD4RTJ3	half	
						SPHWH2L3D30DD4RTK3	half	
						SPHWH2L3D30DD4RTM3	half	

()* : Minimum luminous flux @ 25°C

Notes:

- 1) SAMSUNG ELECTRONICS maintains a tolerance of ±3.0 on CRI measurements.
- 2) SAMSUNG ELECTRONICS maintains a tolerance of ±7% on flux measurements.
- 3) Calculated flux values are for reference only.



1. Luminous Flux Characteristics (T_j= 85°C)

Nominal CCT	Minimum CRI ⁽¹⁾	Sorting condition Flux ⁽²⁾ @350mA		Calculated Minimum Flux ⁽³⁾			Product Code	BIN Structure
		Rank	Min Flux ⁽²⁾	@700mA	@1000mA	@1500mA		
5700K	70	J3 (K3)	120 (130)	216 (234)	284 (308)	377 (408)	SPHWH2L3D30CD4QTJ3	half
		K3 (M3)	130 (140)	234 (253)	308 (333)	408 (441)	SPHWH2L3D30CD4QTK3	half
		M3 (N3)	140 (150)	253 (270)	333 (355)	441 (471)	SPHWH2L3D30CD4QTM3	half
	75	J3 (K3)	120 (130)	216 (234)	284 (308)	377 (408)	SPHWH2L3D30DD4QTJ3	half
		K3 (M3)	130 (140)	234 (253)	308 (333)	408 (441)	SPHWH2L3D30DD4QTK3	half
		M3 (N3)	140 (150)	253 (270)	333 (355)	441 (471)	SPHWH2L3D30DD4QTM3	half
6500K	70	J3 (K3)	120 (130)	216 (234)	284 (308)	377 (408)	SPHWH2L3D30CD4PTJ3	half
		K3 (M3)	130 (140)	234 (253)	308 (333)	408 (441)	SPHWH2L3D30CD4PTK3	half
		M3 (N3)	140 (150)	253 (270)	333 (355)	441 (471)	SPHWH2L3D30CD4PTM3	half

()* : Minimum luminous flux @ 25°C

Notes:

- 1) SAMSUNG ELECTRONICS maintains a tolerance of ±3.0 on CRI measurements.
- 2) SAMSUNG ELECTRONICS maintains a tolerance of ±7% on flux measurements.

2. Characteristics

1) Electro-optical Characteristics

Item	Unit	Min	Typ	Max
Forward voltage ¹⁾ (@350 mA, T _j = 85°C)	V	2.60	2.85	3.00
Forward voltage ¹⁾ (@700 mA, T _j = 85°C)	V		3.02	
Forward voltage ¹⁾ (@1000 mA, T _j = 85°C)	V		3.13	
Forward voltage ¹⁾ (@1500 mA, T _j = 85°C)	V		3.29	
Operation forward current (T _j = 85°C)	mA	-	-	1500
Thermal resistance, junction to solder point	°C/W	-	4	6
LED junction temperature T _j	°C	-	-	150
Operating temperature range T _{opr}	°C	-40	-	85
Storage temperature range T _{stg}	°C	-40	-	120
Viewing Angle	°	-	120	-

Item	Unit	3000K	5000K
Forward voltage ¹⁾ (@350 mA, T _j = 25°C)	V	2.95	
Forward voltage ¹⁾ (@350 mA, T _j = 85°C)	V	2.85	
Luminous flux ²⁾ (@350 mA, T _j = 25°C)	lm	118	144
Luminous flux ²⁾ (@350 mA, T _j = 85°C)	lm	108	133
Luminous flux ²⁾ (@700 mA, T _j = 85°C)	lm	194	239
Luminous flux ²⁾ (@1000 mA, T _j = 85°C)	lm	256	315
Luminous flux ²⁾ (@1500 mA, T _j = 85°C)	lm	339	418

Notes:

- 1) SAMSUNG ELECTRONICS maintains a tolerance of ±0.1V on forward voltage measurements.
- 2) Characteristics @ 25°C are for reference only.

2) Vf Rank

(T_j = 85°C)

Parameter	Symbol	Condition	Rank	Min.	Typ.	Max.
Forward Voltage	V _F	I _F = 350mA	D4	2.60	-	3.00

3. Typical Characteristics Graph

1) Spectrum Distribution

2700K(CRI 80) & 3000K(CRI 80)

(T_j = 85°C)

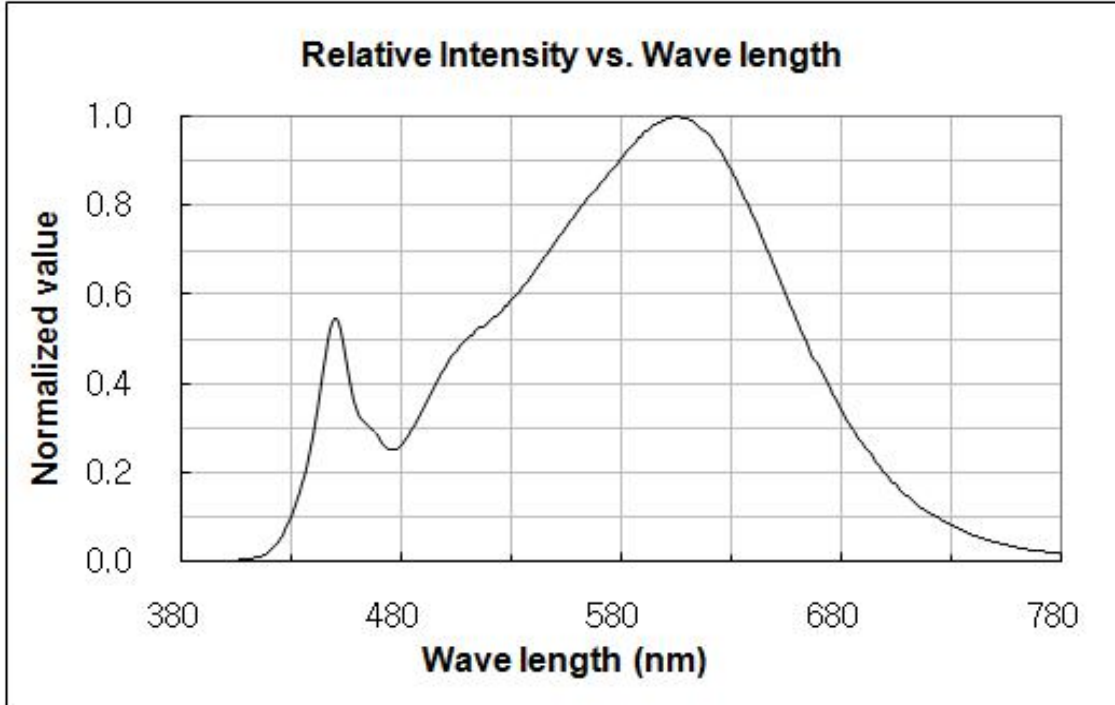

5000K(CRI 70) & 5700K(CRI 70)

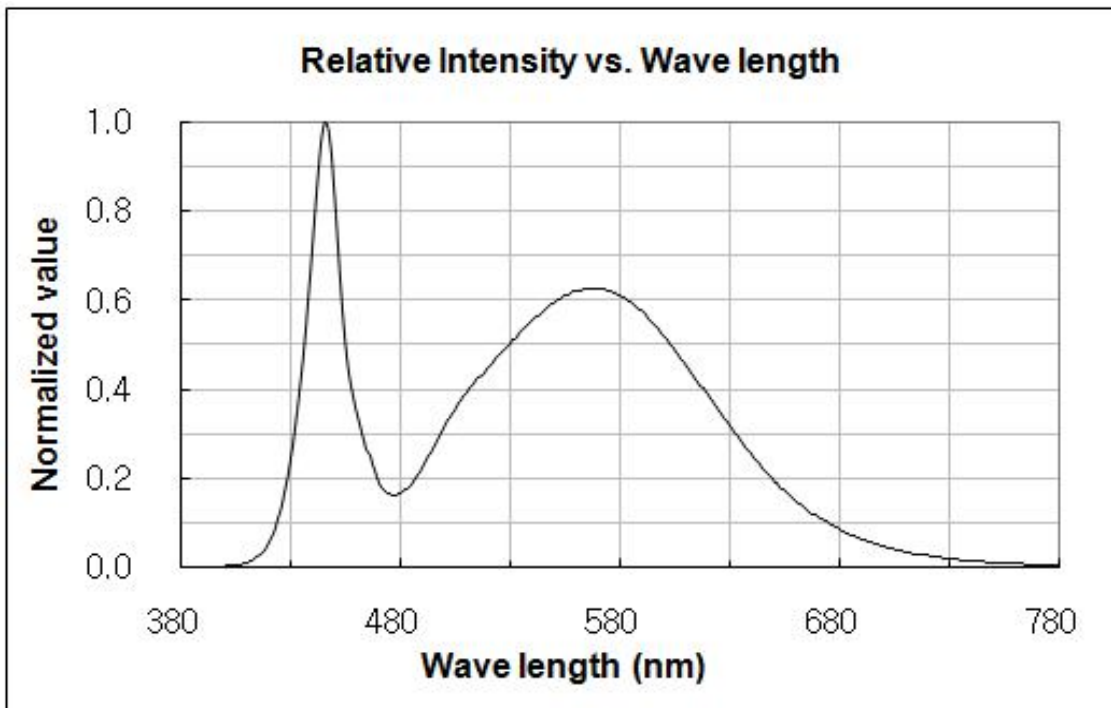

2) Forward Current Characteristics

Relative Flux vs. Forward Current

($T_j = 85^\circ\text{C}$)

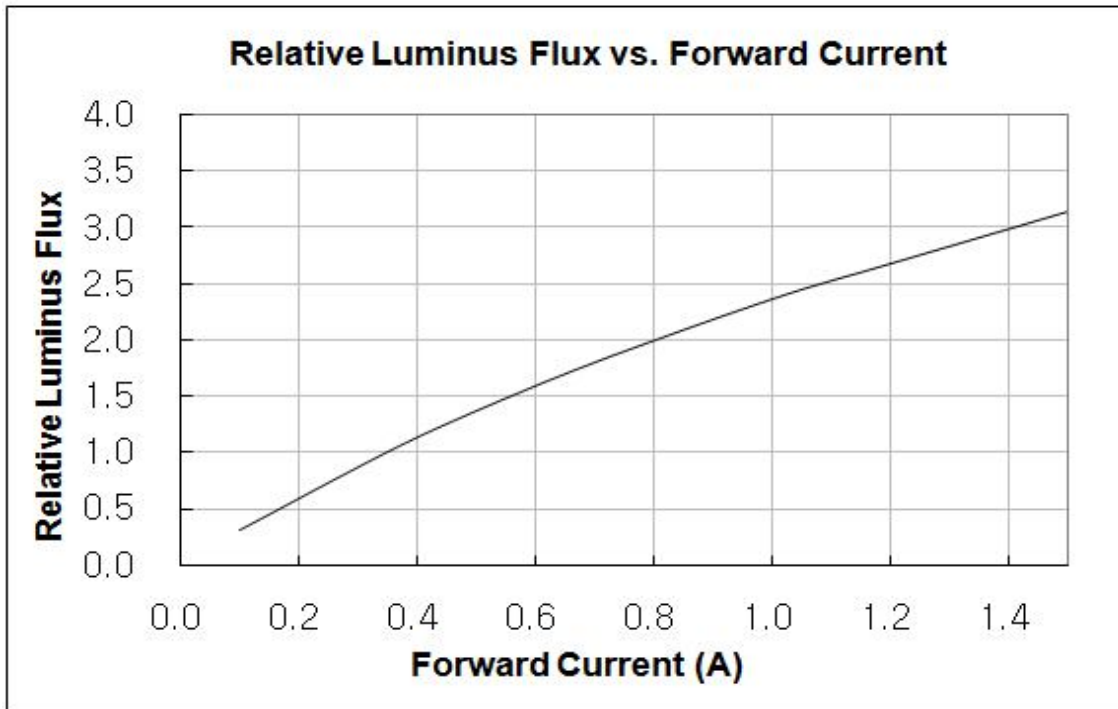

Forward Current vs. Forward Voltage

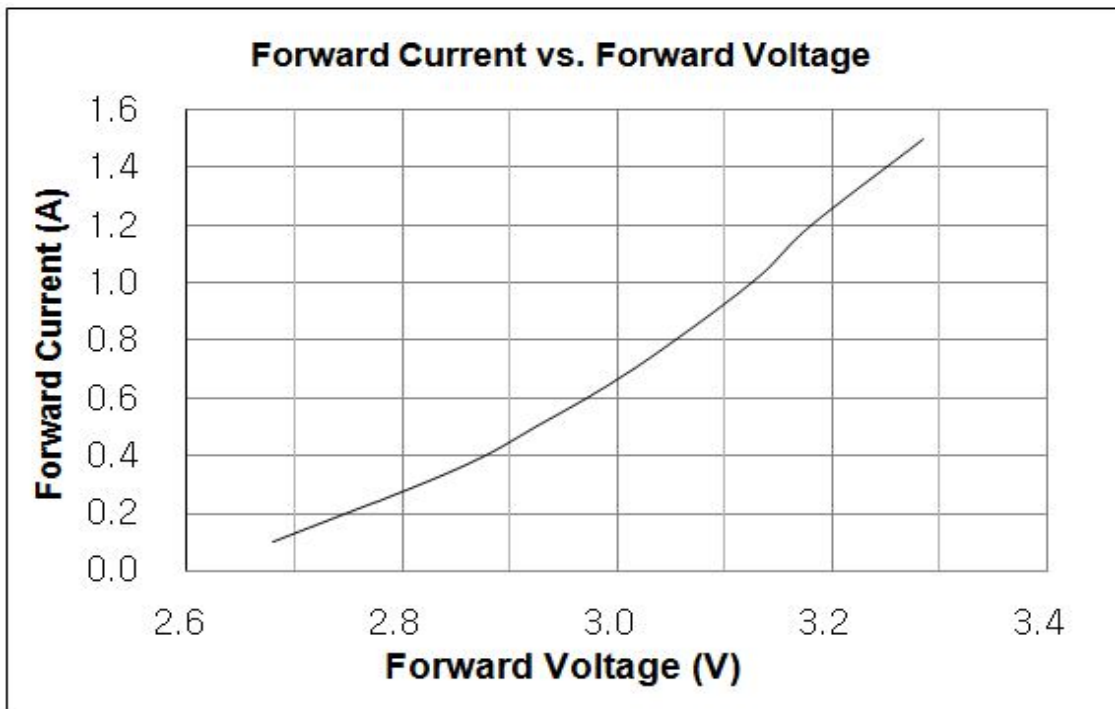

3) Temperature Characteristics

Relative Flux vs. Tj(Junction temp.)

($I_F = 350\text{mA}$)

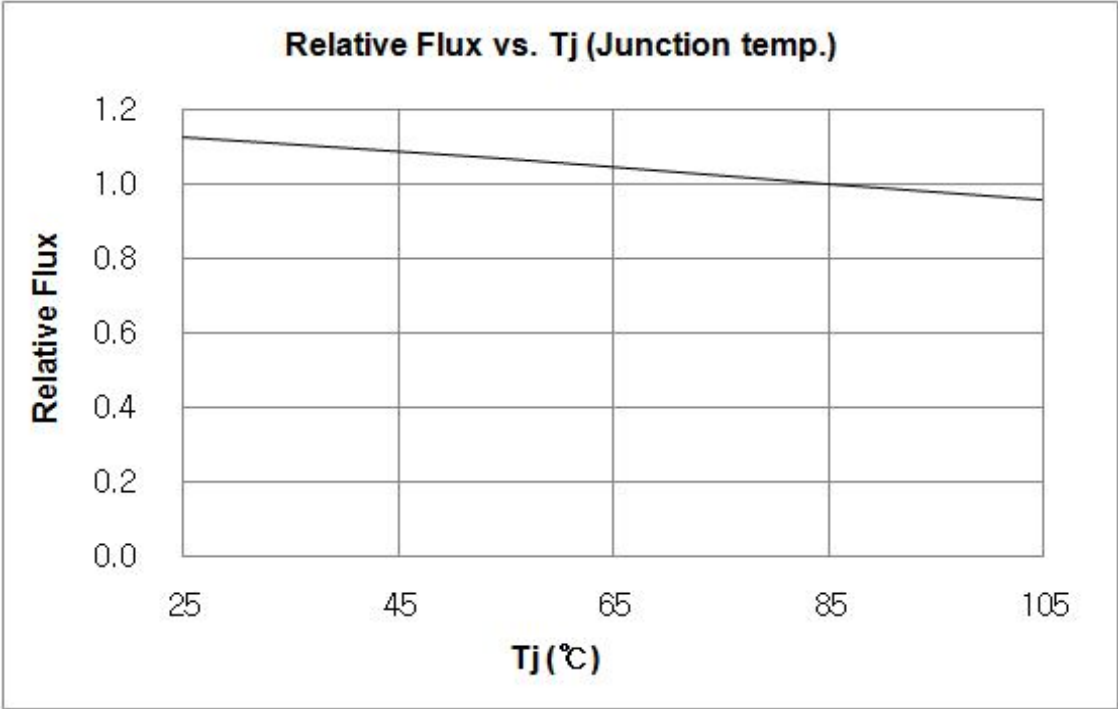

Forward Voltage vs. Tj(Junction temp.)

($I_F = 350\text{mA}$)

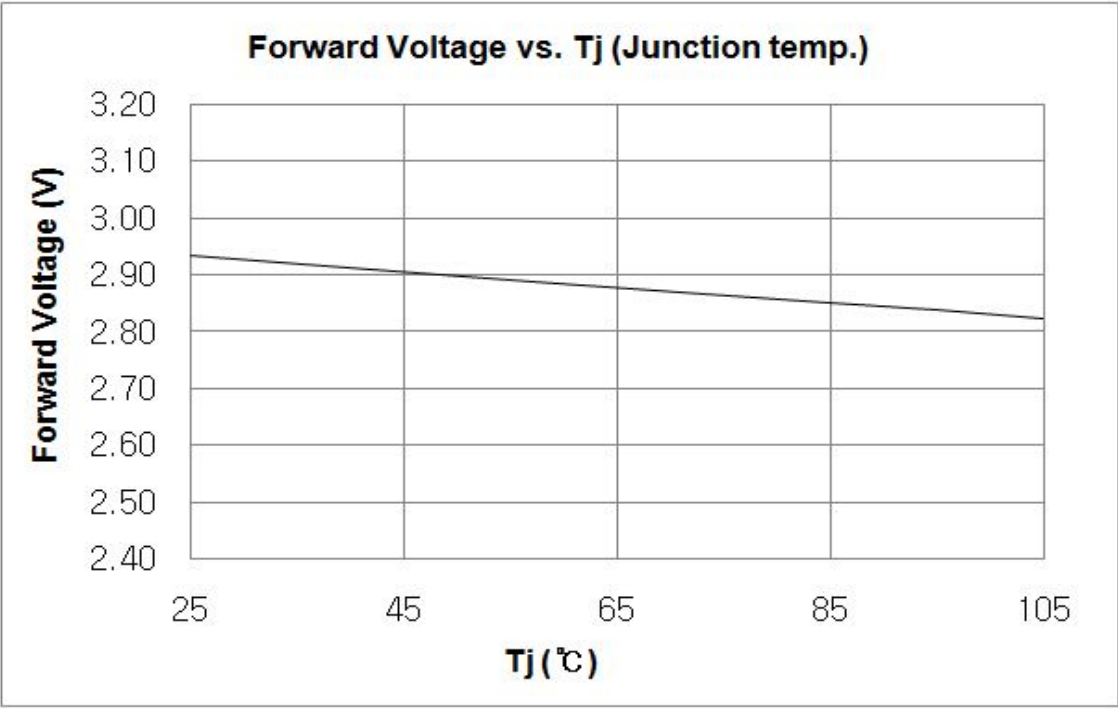

4) Color shift Characteristics

Color x,y vs. Forward Current [Cool White]

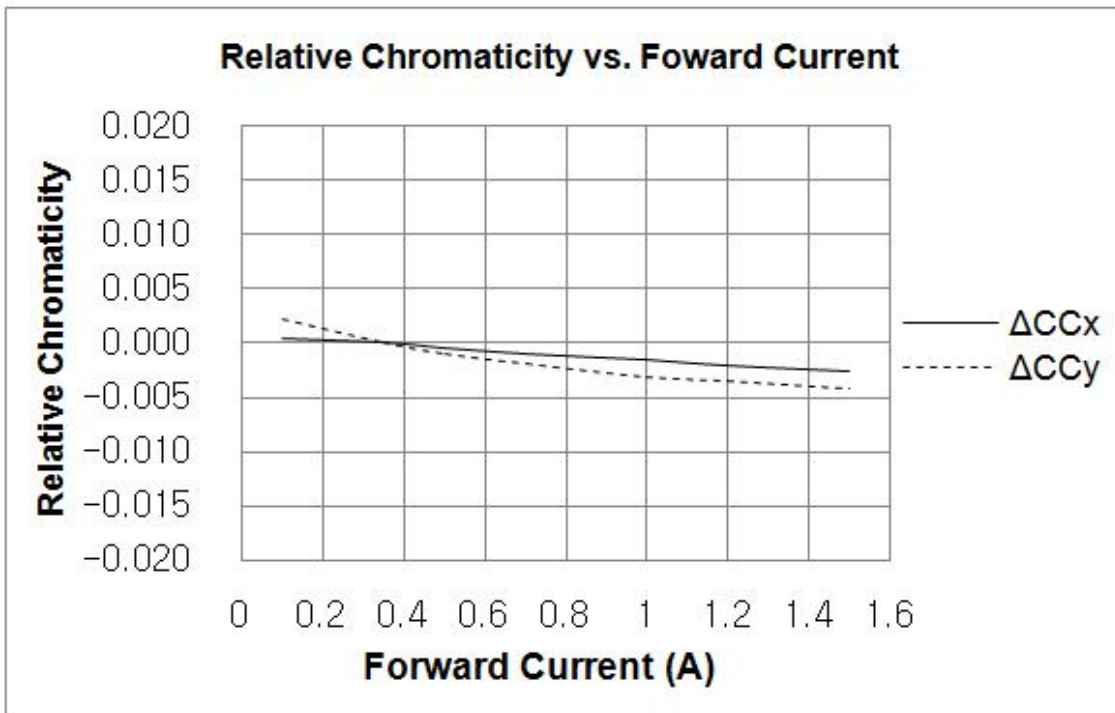

Color x,y vs. Tj(Junction temp.) [Cool White]

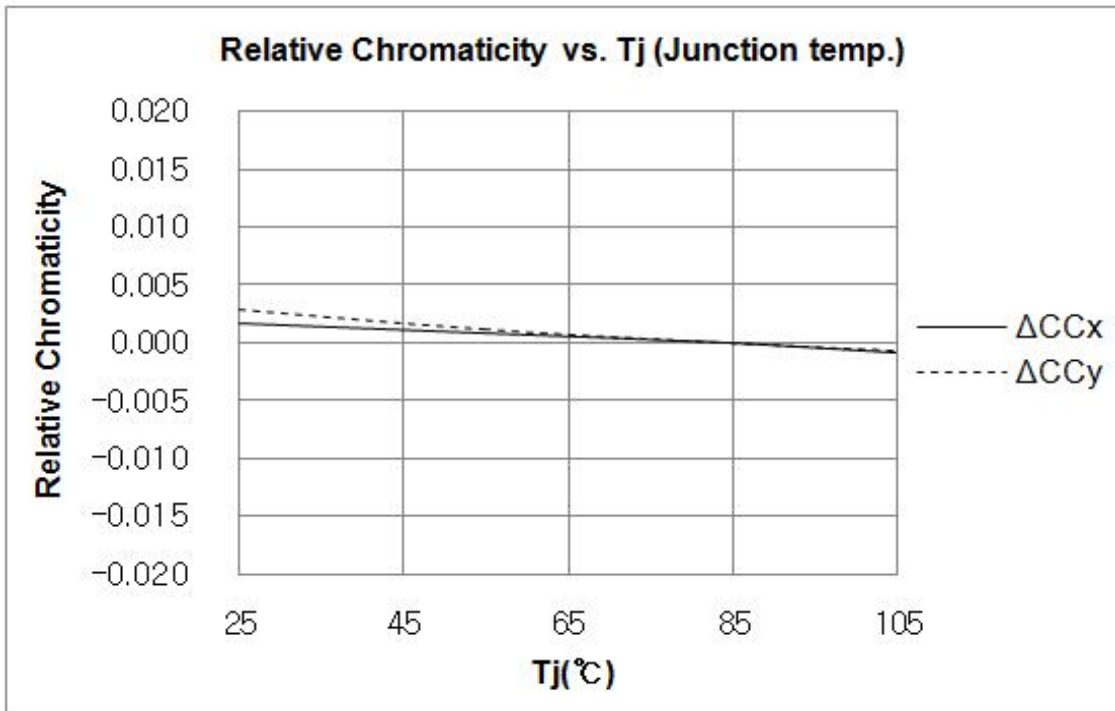

5) Derating Curve

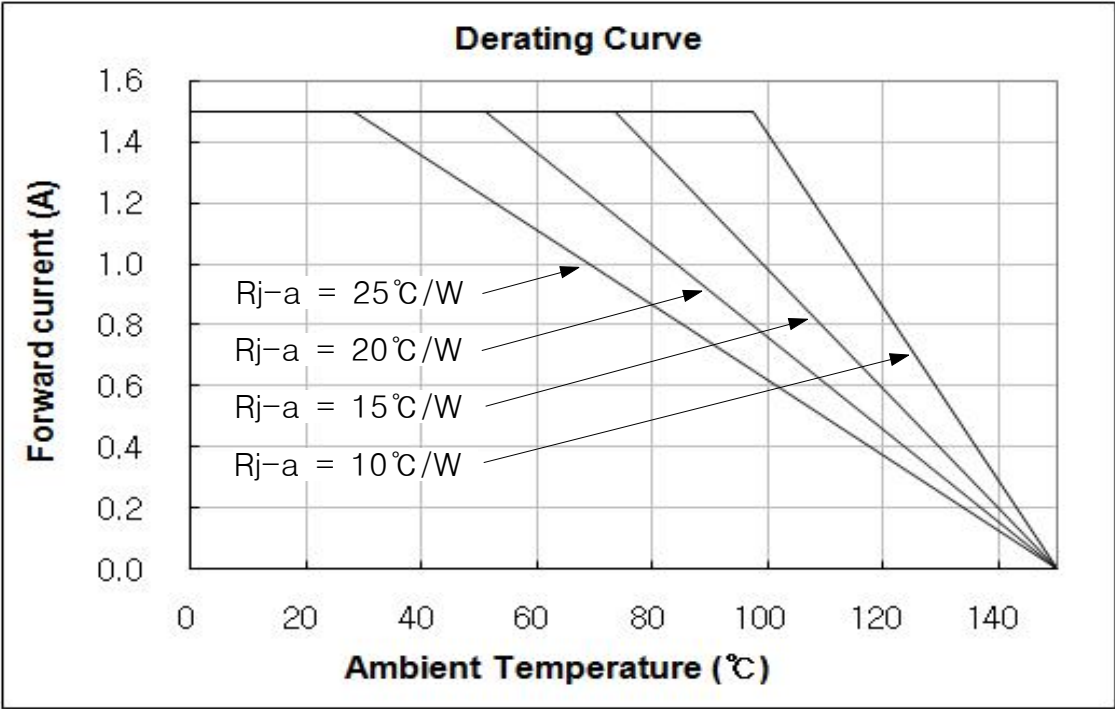

6) Viewing angle Characteristics

Viewing angle

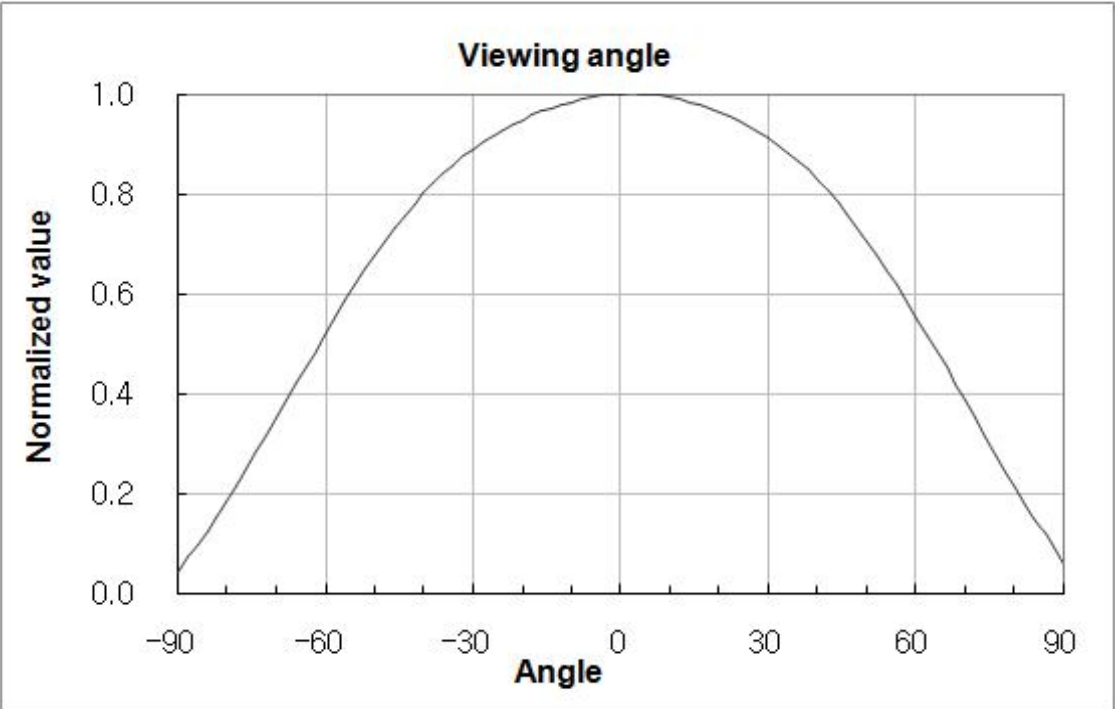

4. Outline Drawing & Dimension

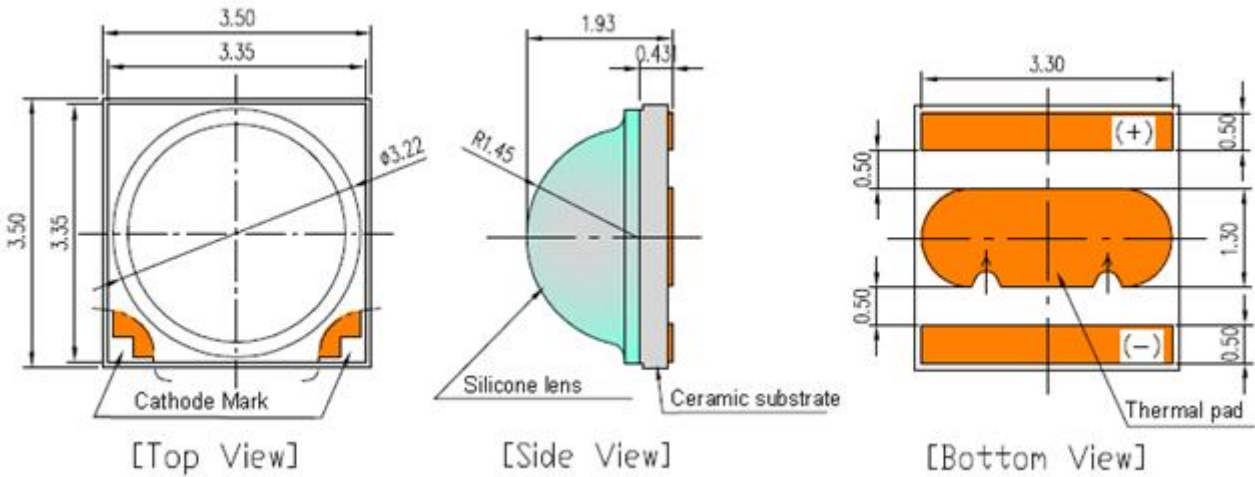

Recommended Land Pattern

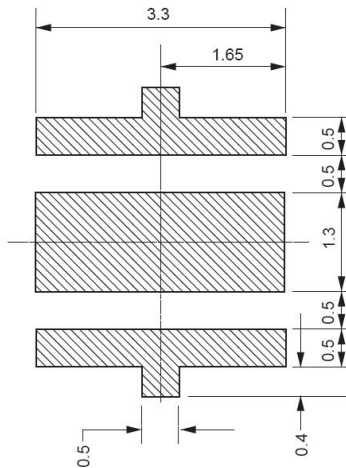

unit : mm

Tolerance : ± 0.13

- * This LED has built-in ESD protection device(s) connected in parallel to LED Chip(s).
- * The thermal pad is electrically isolated from the anode and cathode contact pads.

Ts Point & Measurement Method

- * Measure the nearest point to the thermal pad as shown below. If necessary, remove PSR of PCB to reach Ts point.
- * Thermal pad must be soldered to the PCB to dissipate heat properly. Otherwise, LED can be damaged.

[Bottom view]

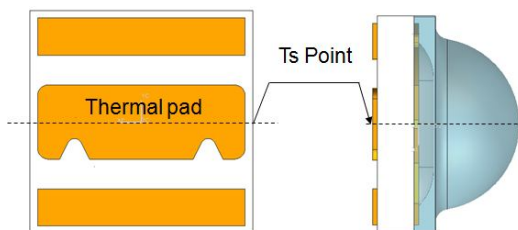

5. Reliability Test Items and Conditions

1) Test Items and Results

Test Items	Test Conditions	Test Hours/Cycles	n
Room Temperature Life Test	25℃, DC 1000 mA	1000 Hr	22
High Temperature humidity Life Test	85℃, 85%, DC 1000 mA	1000 Hr	22
High Temperature Life Test	85℃, DC 1000 mA	1000 Hr	22
Low Temperature Life Test	-40℃, DC 1000 mA	1000 Hr	22
Temperature Humidity Cycle	-10℃ ↔ 25℃ 95%RH ↔ 85℃ 95%RH 1000mA, 95%RH, 24hrs/1cycle	10 Cycles	11
Thermal Shock	-45℃/15 min ↔ 125℃/ 15 min. Temp.change within 5min.	500 Cycles	100
High Temperature Storage	Ta=120℃	1000 Hr	11
Low Temperature Storage	Ta=-40℃	1000 Hr	11
ESD(HBM)	Q1=10MΩ, R2=1.5KΩ, C=100pF, V=±5KV, 5Times	5 Times (±5kV)	5

2) Criteria for Judging the Damage

Item	Symbol	Test Condition [T _a = 25℃]	Limit	
			Min.	Max.
Forward Voltage	V _F	350 mA	L.S.L. * 0.9	U.S.L. * 1.1
Luminous flux	Im	350 mA	L.S.L. * 0.7	U.S.L. * 1.1

* U.S.L. : Upper Standard Level L.S.L. : Lower Standard Level

6. Solder Conditions

1) Reflow Conditions (Pb Free)

Reflow Frequency : 2 times max.

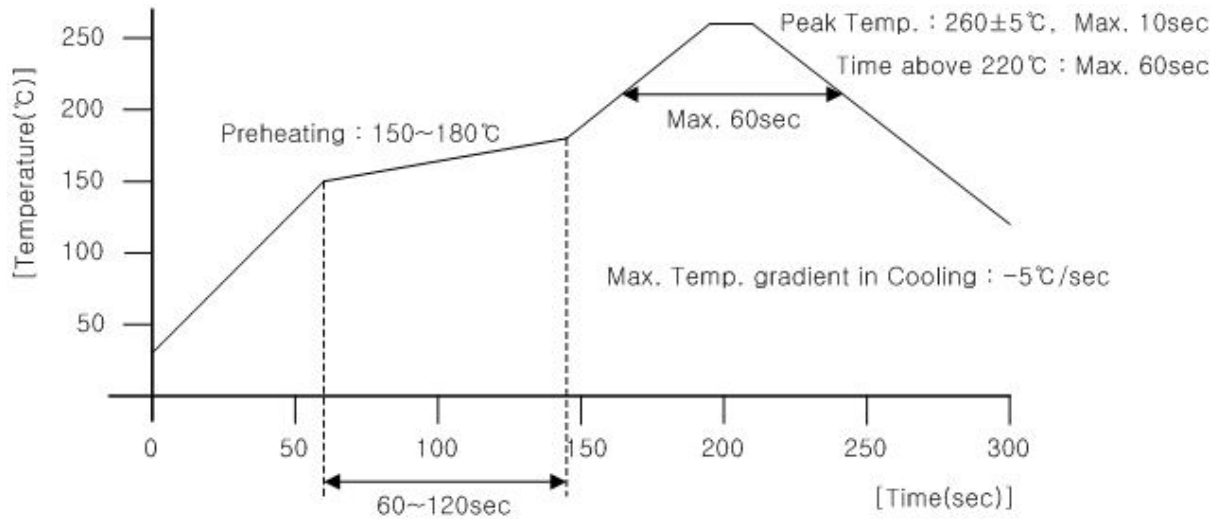

2) For Manual Soldering

Not more than 5 seconds @Max. 300°C, under soldering iron.

7. Tape And Reel

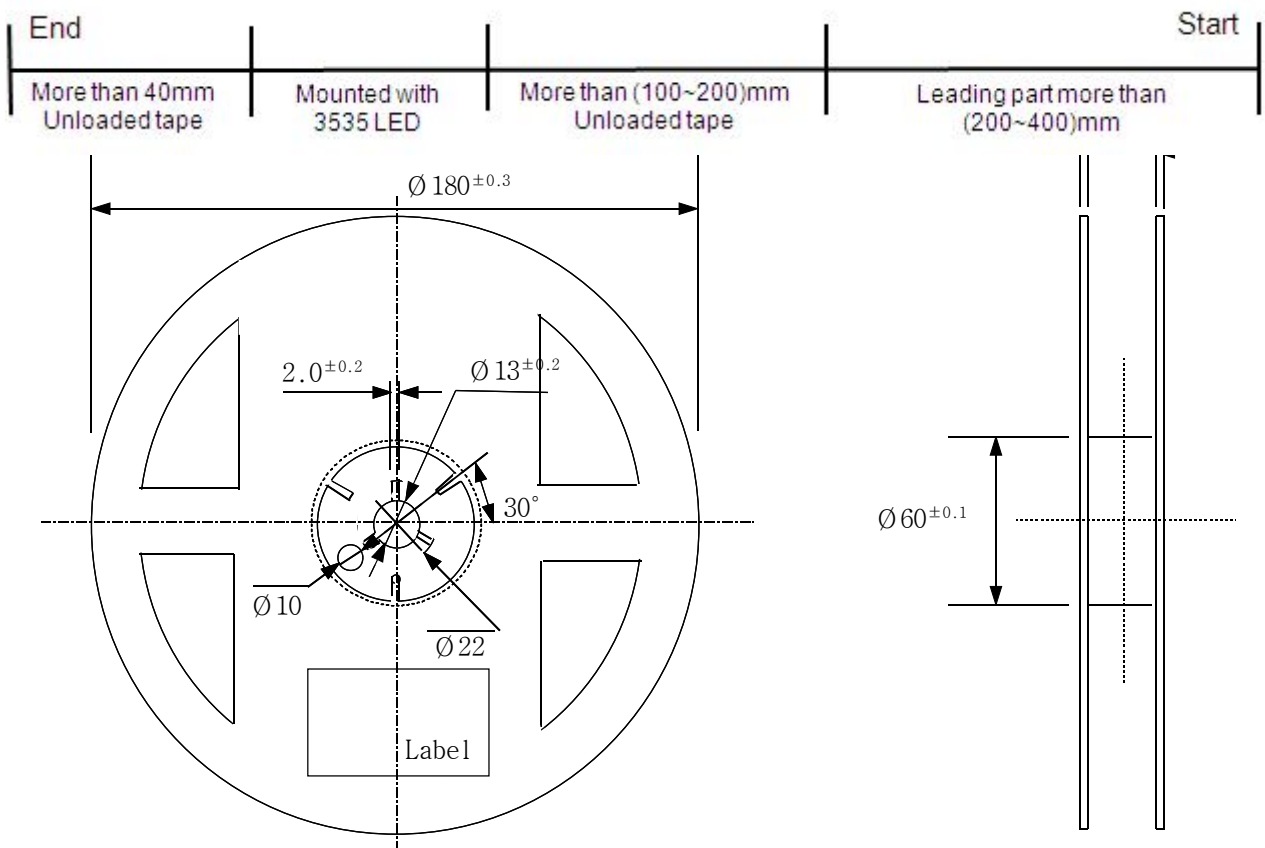
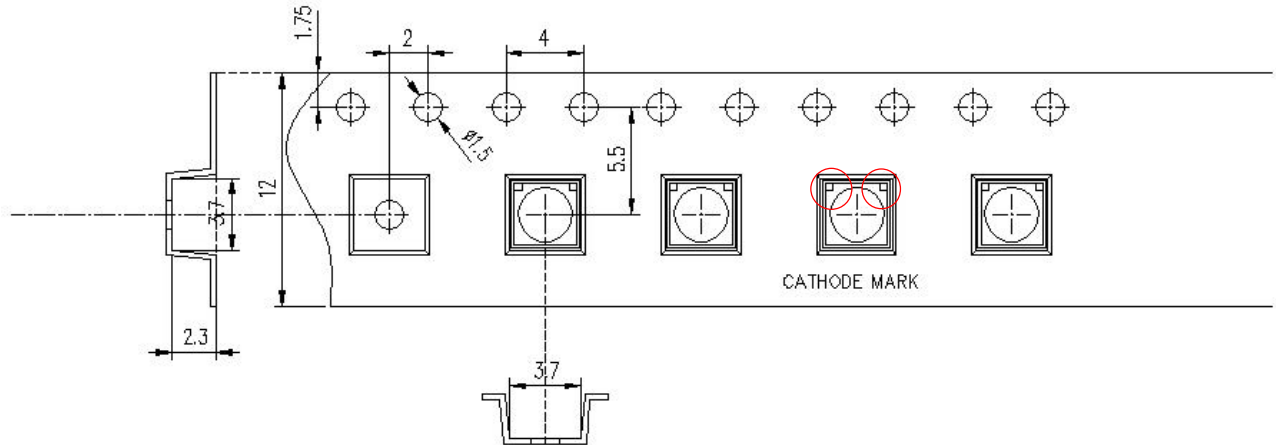

- (1) Quantity : The quantity/reel to be 1,000 pcs.
- (2) Cumulative Tolerance : Cumulative tolerance/10 pitches to be ± 0.2 mm
- (3) Adhesion Strength of Cover Tape : Adhesion strength to be 0.1-0.7N when the cover tape is turned off from the carrier tape at 10° angle to be the carrier tape.
- (4) Packaging : P/N, Manufacturing data code no. and quantity to be indicated on a damp proof package.



8. Label Structure

1) Label Structure



Rank Code

/D4/ : VF Rank

/V1/ : Color Rank

/G1/ : Flux Bin

2) LOT Number

The Lot number is composed of the following characters

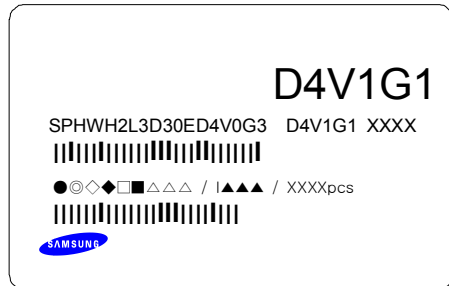

●◎◇◆□■△△△ / |▲▲▲ / 1000PCS

● : Production Site (S:SAMSUNG ELECTRONICS, G:Gosin China)

◎ : L (LED)

◇ : Product State (A:Normality, B:Bulk, C:First Production, R:Reproduction, S:Sample)

◆ : Year (S:2008, T:2009, U:2010, V:2011, W:2012, X:2013, Y:2014, Z:2015)

□ : Month (1 ~ 9, A, B)

■ : Day (1 ~ 9, A, B ~ V)

△ : SAMSUNG ELECTRONICS Product Number (1 ~ 999)

▲ : Reel Number (1 ~ 999)



9. Packing Structure

1) Packing Process

Reel

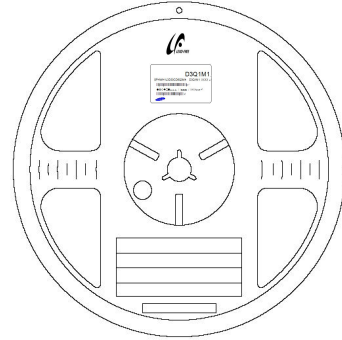

Aluminum Vinyl Bag



Out Box (Max. 7 Aluminum Vinyl Bag)



Material :

Paper(DW2A/DW(AB))

TYPE	SIZE(mm)		
	a	b	c
7inch	250	225	190

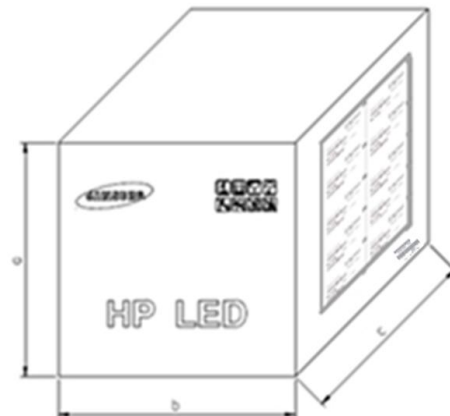

2) Aluminum Packing Bag



CAUTION

This bag contains
MOISTURE SENSITIVE DEVICES

LEVEL

2a

1. Shelf life in sealed bag: 12 months at 40°C and 90% relative humidity (RH)
2. Peak package body temperature: 240°C
3. After this bag is opened, devices that will be subjected to reflow solder or other high temperature processes must be:
 - a. Mounted within 672 hours at factory conditions of equal to or less than 30°C / 60% RH, or
 - b. Stored at 10% RH
4. Devices require bake, before mounting, if:
 - a. Humidity Indicator Card is > 65% when read at $23 \pm 5^{\circ}\text{C}$, or
 - b. 2a is not met.
5. If baking is required, devices must be baked for 1 hours at $60 \pm 5^{\circ}\text{C}$

Note: if device containers cannot be subjected to high temperature or shorter bake times are desired, reference IPC/JEDEC J-STD-033 for bake procedure,

Bag seal due date: _____
(if blank, see code label)

Note: Level and body temperature by IPC/JEDEC J-STD-020

D4V1G1

SPHWH2L3D30ED4V0G3 D4V1G1 XXXX



●◎◇◆□△△△ / ▲▲▲ / XXXXpcs



SAMSUNG



S3C6810X01-Y540

QTY: 2000 U/W: 1201 AS

LOT: N42KNMC QTY: 2000 U/W: 1201 AS

ASSEMBLED IN KOREA FROM DIE OF KOREA



LEAD-FREE





ATTENTION
OBSERVE PRECAUTIONS
FOR HANDLING
ELECTROSTATIC
SENSITIVE
DEVICES



OTHER

■ 주의 사항

이 알루미늄 지퍼 백은 습기 및 정전기로부터 제품을 보호하기 위하여 제작되었습니다. 개봉 후에는 즉시 솔더 작업을 실시하는 것을 권장합니다.

습기 및 정전기로부터 제품을 보호 하기 위해서 개봉 후 사용하지 않는 자재를 본 팩에 넣어 보관 하시기 바랍니다. 사용하지 않는 자재를 본 팩에 넣을 때는 반드시 동봉된 드라이 팩과 함께 넣고 지퍼부분을 완전하게 밀봉하여 주시기 바랍니다.

■ Important

This Al Zipper bag is designed to protect the enclosed products from moisture and ESD. Once opened, the products should be soldered onto the printed circuit board immediately. When not in use, please do not leave the products unprotected by the Al Zipper Bag. To repack unused products., please ensure the zip-lock is completely sealed with the dry pack left inside.

There are Silica Gel and Humidity Indicator Card in the Aluminum Bag

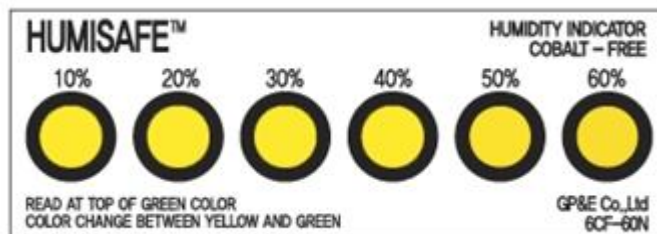

10. Precaution for use

- 1) For over current-protection, customers are recommended to apply resistors connected in series with the LEDs to mitigate sudden change of the forward current caused by shift of the forward voltage.
- 2) This device should not be used in any type of fluid such as water, oil, organic solvent, etc. When cleaning is required, IPA is recommended as cleaning agent. Solvent-based cleaning agent such as Zestron^(R) may damage the silicone resins used in the device.
- 3) When the device is in operation, the forward current should be carefully determined considering the maximum ambient temperature and the corresponding junction temperature.
- 4) LEDs must be stored in a clean environment. If the LEDs are to be stored for 3 months or more after being shipped from SAMSUNG ELECTRONICS, they should be packed with a nitrogen-filled container.
(Shelf life of sealed bags: 12 months, temp. 0~40°C, 0~90%RH)
- 5) After storage bag is open, device subject to soldering, solder reflow, or other high temperature processes must be:
 - a. Mounted within 672 hours (28 days) at an assembly line with a condition of no more than 30°C/60%RH.
 - b. Stored at <10% RH.
- 6) Repack unused Products with anti-moisture packing, fold to close any opening and then store in a dry place.
- 7) Devices require baking before mounting, if humidity card reading reaches 60% at 23±5°C.
- 8) Devices must be baked for 1hours at 60±5°C, if baking is required.
- 9) The LEDs are sensitive to the static electricity and surge current. It is recommended to use a wrist band or anti-electrostatic glove when handling the LEDs.
If voltage exceeding the absolute maximum rating is applied to LEDs, it may cause damage or even destruction to LED devices.
Damaged LEDs may show some unusual characteristics such as increase in leakage current, lowered turn-on voltage, or abnormal lighting of LEDs at low current.
- 10) VOCs (volatile organic compounds) can be generated from adhesives, flux, hardener or organic additives used in luminaires (fixtures). Transparent LED silicone encapsulant is permeable to those chemicals and they may lead a discoloration of encapsulant when they expose to heat or light. This phenomenon can cause a significant loss of light emitted(output) from the luminaires(fixture). This phenomenon can give a significant loss of light emitted(output) from the luminaires(fixture). In order to prevent these problems, we recommend you to know the physical properties of materials used in luminaires, They must be selected carefully.



11) Risk of Sulfurization (or Tarnishing)

The LED from Samsung Electronics uses a silver-plated lead frame and its surface color may change to black(or dark colored) when it is exposed to sulfur (S), chlorine (Cl) or other halogen compound. Sulfurization of lead frame may cause intensity degradation, change of chromaticity coordinates and, in extreme cases, open circuit. It requires caution. Due to possible sulfurization of lead frame, LED should not be used and stored together with oxidizing substances made of materials in a following list, : Rubber, plain paper, lead solder cream and so on.

X-ON Electronics

Largest Supplier of Electrical and Electronic Components

Click to view similar products for [High Power LEDs - Single Color](#) category:

Click to view products by [Samsung](#) manufacturer:

Other Similar products are found below :

[L135-L567003500000](#) [L1CU-VLT1000000000](#) [GW PSLMS1.EC-GTHP-5J7K-1](#) [LT G5AP-CZEX-36-1](#) [ASMT-MB00-NDF00](#) [LD G5AP-4M4N-35-1](#) [XPEBRY-L1-0000-00S02](#) [XQEBLU-00-0000-000000Z02](#) [SPHWH2L3D30ED4V0H3](#) [XQEBLU-00-0000-000000202](#)
[LUWCQ7P-LPLR-5E8G-1-K](#) [KA-3535SELZ4S](#) [GY CS8PM1.23-KQKS-36](#) [GH CSSPM1.24-4T2U-1](#) [L1SP-DRD0002000000](#) [L1SP-LME0002000000](#) [LHUV-0395-A060](#) [VLMTG1400-GS08](#) [XPGDRY-L1-0000-00601-SB01](#) [XTEARY-00-0000-000000L02](#) [XQEGRN-H0-0000-000000901](#) [XPEEPR-L1-0000-00B01](#) [XPERED-L1-0000-00801](#) [XTEARY-00-0000-000000M04](#) [XPGDRY-L1-0000-00401](#) [XQEEPR-00-0000-000000901](#) [XQEEPR-00-0000-000000A01](#) [15335340AA350](#) [XPCRDO-L1-R250-00701](#) [XPEGRN-L1-0000-00F02](#) [XRCRDO-L1-R250-00K03](#) [15335339AA350](#) [XQERDO-02-0000-000000701](#) [XPEBGR-L1-0000-00E02](#) [XPEROY-L1-R250-00B02](#) [15335338AA350](#) [XPEROY-L1-R250-00903](#) [XPEBRY-L1-R250-00R01](#) [XPCBLU-L1-R250-00Y01](#) [XPEGRN-L1-0000-00F01](#) [XPEBPA-L1-R250-00B01](#) [XPERED-L1-R250-00802](#) [XQEBLU-02-0000-000000305](#) [XTEARY-00-0000-000000K03](#) [XTEARY-02-0000-000000L03](#) [XPEBBL-L1-R250-00302](#) [VLMY71AAAC-GS08](#) [XPCGRN-L1-R250-00601](#) [LS H9PP-HYJY-1-1](#) [XPEROY-L1-0000-00B02](#)