

# Secondary-Side Synchronous Rectifier Driver

## FEATURES

- Works with DCM and BCM/CrCM Conduction Mode Flyback Topologies
- $V_{CC}$ : 4.5V to 40V
- Supports Up to 150V MOSFETs
- 26ns Turn-Off Propagation Delay
- Accurate Minimum On and Off Timers for Reliable Operation
- Adjustable and Accurate Trip Point: +5mV to -30mV
- 1 $\Omega$  Gate Driver Pull-Down
- SOT-23 5-Lead Package

## APPLICATIONS

- High Output Current Flybacks
- High Efficiency Flybacks

## DESCRIPTION

The **LT<sup>®</sup>8309** is a secondary-side synchronous rectifier driver that replaces the output rectifier diode in a flyback topology. By replacing the diode with a N-channel MOSFET, applications are no longer restricted by the heat constraints of the output diode. The IC replicates the behavior of a diode by sensing the drain-to-source voltage to determine when the current becomes negative. The LT8309's low minimum on- and off-times help improve noise immunity.

The fast propagation delay of 26ns allows applications to operate in discontinuous conduction mode (DCM) and critical conduction mode (CrCM). The gate driver features a 0.8 $\Omega$  pull-down device for fast turn-offs. The 40V  $V_{CC}$  rating allows the part to be driven from the output voltage or the rectified drain voltage of the MOSFET. A low quiescent current of 400 $\mu$ A maximizes efficiency at low output currents.

LT, LT, LTC, LTM, Linear Technology and the Linear logo are registered trademarks of Linear Technology Corporation. All other trademarks are the property of their respective owners.

## TYPICAL APPLICATION

40W, 5V Isolated Telecom Supply

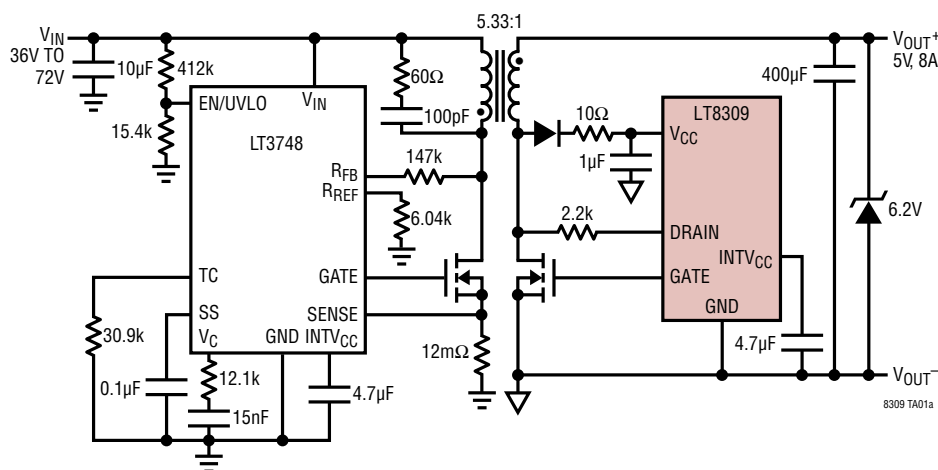

Efficiency vs Load Current

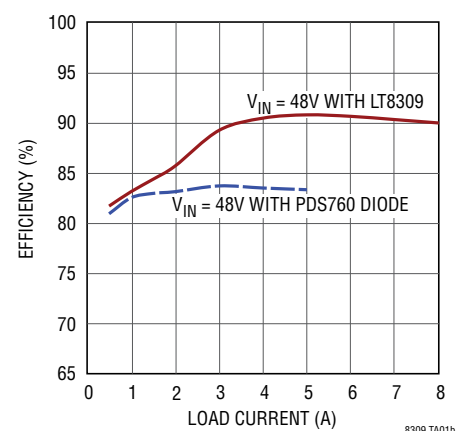

# LT8309

## ABSOLUTE MAXIMUM RATINGS

(Note 1)

$V_{CC}$ .....	40V
INTV <sub>CC</sub> GATE .....	10V
DRAIN.....	150V
Maximum Junction Temperature .....	125°C
Operating Temperature Range (Note 2)	
LT8309E .....	-40°C to 125°C
LT8309I .....	-40°C to 125°C
LT8309H.....	-40°C to 150°C
Storage Temperature Range .....	-65°C to 150°C

## PIN CONFIGURATION

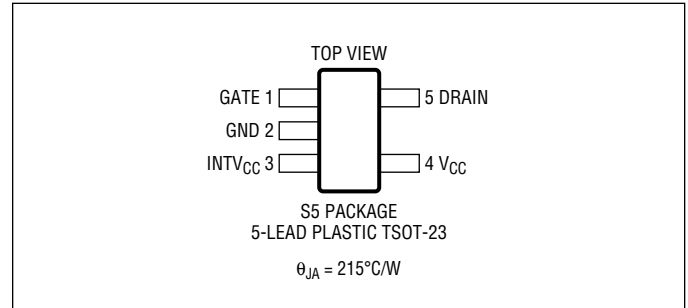

## ORDER INFORMATION

LEAD FREE FINISH	TAPE AND REEL	PART MARKING*	PACKAGE DESCRIPTION	TEMPERATURE RANGE
LT8309ES5#PBF	LT8309ES5#TRPBF	LTGFZ	5-Lead Plastic TSOT-23	-40°C to 125°C
LT8309IS5#PBF	LT8309IS5#TRPBF	LTGFZ	5-Lead Plastic TSOT-23	-40°C to 125°C
LT8309HS5#PBF	LT8309HS5#TRPBF	LTGFZ	5-Lead Plastic TSOT-23	-40°C to 150°C

Consult LTC Marketing for parts specified with wider operating temperature ranges. \*The temperature grade is identified by a label on the shipping container.

For more information on lead free part marking, go to: <http://www.linear.com/leadfree/>

For more information on tape and reel specifications, go to: <http://www.linear.com/tapeandreel/>

**ELECTRICAL CHARACTERISTICS** The ● denotes the specifications which apply over the full operating temperature range, otherwise specifications are at  $T_A = 25^\circ\text{C}$ .

PARAMETER	CONDITIONS		MIN	TYP	MAX	UNITS
Input Voltage Range		●	4.5		40	V
$V_{CC}$ Quiescent Current	Not Switching, $INTV_{CC} = 8\text{V}$			300	345	$\mu\text{A}$
<b>Comparator</b>						
Turn-On Threshold	$R_S = 0\Omega$	●	-69	-57	-45	mV
Turn-Off Threshold	$R_S = 0\Omega$	●	17 16	21	25 28	mV mV
Drain Voltage Latch Reset	$R_S = 0\Omega$			1.21		V
Minimum Off-Time			75	95	115	ns
Minimum On-Time			310	360	410	ns
Drain Current	Out of Pin	●	9.5	10	10.5	$\mu\text{A}$
<b>INTV<sub>CC</sub> Linear Regulator</b>						
INTV <sub>CC</sub> Quiescent Current	Not Switching, $INTV_{CC} = 8\text{V}$			100	117	$\mu\text{A}$
INTV <sub>CC</sub> Voltage Range			4.5		10	V
INTV <sub>CC</sub> Regulation Voltage		●	6.8	7	7.2	V
INTV <sub>CC</sub> UVLO					4.03	V
Dropout ( $V_{CC}$ to INTV <sub>CC</sub> )	$I_{INTV_{CC}} = -10\text{mA}$ , $V_{IN} = 7\text{V}$		1	1.3	1.6	V
Current Limit		●	30	42	55	mA
<b>Gate Driver</b>						
Turn-On Propagation Delay ( $t_{D(ON)}$ )	$R_S = 0\Omega$ , $-100\text{mV}_{OD}$ , $V_{DS}$ to $V_{GATE}$			31	40	ns
Turn-Off Propagation Delay ( $t_{D(OFF)}$ )	$R_S = 0\Omega$ , $-100\text{mV}_{OD}$ , $V_{DS}$ to $V_{GATE}$			26	36	ns
$t_r$ GATE Driver Output Rise Time	$C_L = 3300\text{pF}$			21		ns
$t_f$ GATE Driver Output Fall Time	$C_L = 3300\text{pF}$			11		ns
Pull-Up Resistance				2.7		$\Omega$
Pull-Down Resistance				0.8		$\Omega$

**Note 1:** Stresses beyond those listed under Absolute Maximum Ratings may cause permanent damage to the device. Exposure to any Absolute Maximum Rating condition for extended periods may affect device reliability and lifetime.

**Note 2:** The LT8309E is guaranteed to meet performance specifications from  $0^\circ\text{C}$  to  $125^\circ\text{C}$  operating junction temperature. Specifications over the  $-40^\circ\text{C}$  to  $125^\circ\text{C}$  operating junction temperature range are assured by design, characterization and correlation with statistical process controls. The LT8309I is guaranteed over the full  $-40^\circ\text{C}$  to  $125^\circ\text{C}$  operating junction

temperature range. The LT8309H is guaranteed over the full  $-40^\circ\text{C}$  to  $150^\circ\text{C}$  operating junction temperature range. High junction temperatures degrade operating lifetimes. Operating lifetime is derated at junction temperatures greater than  $125^\circ\text{C}$ .

**Note 3:** The LT8309 includes overtemperature protection that is intended to protect the device during momentary overload conditions. Junction temperature will exceed  $150^\circ\text{C}$  when overtemperature protection is active. Continuous operation above the specified maximum operating junction temperature may impair device reliability.

# TYPICAL PERFORMANCE CHARACTERISTICS

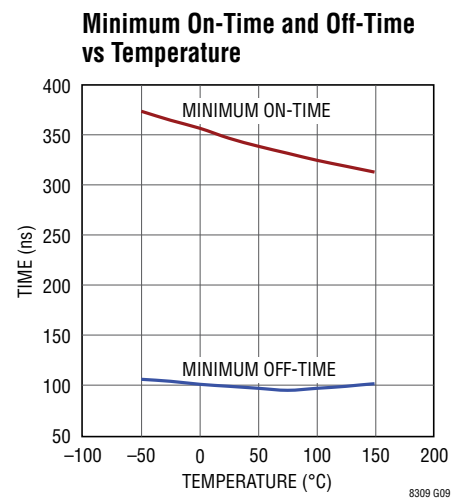
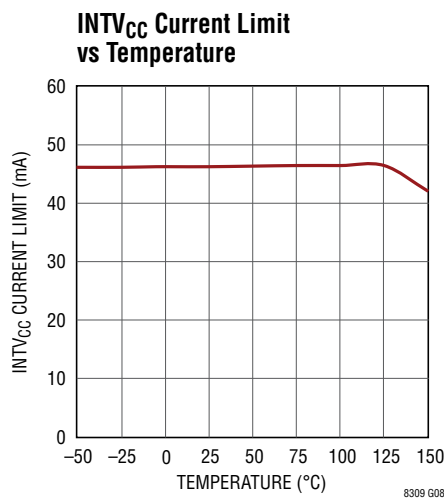
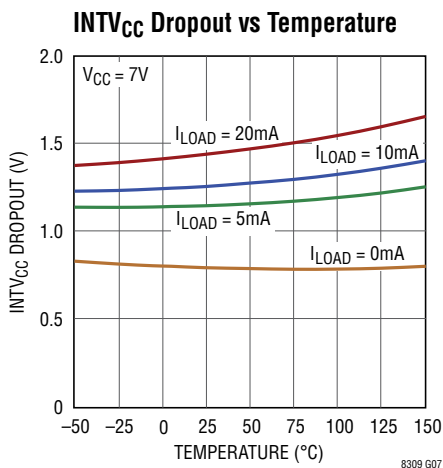
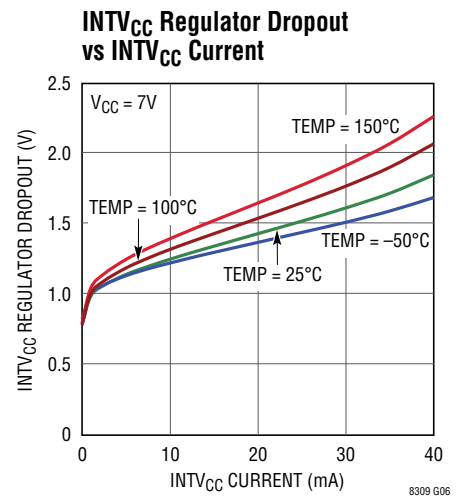
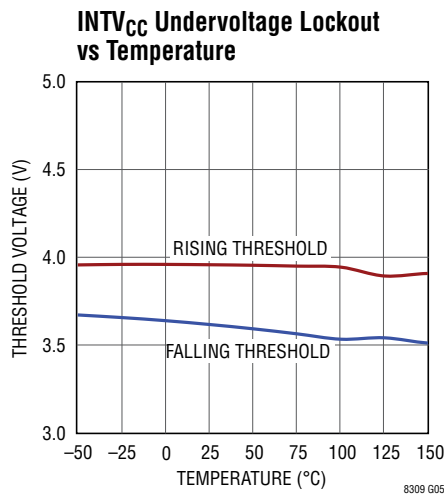
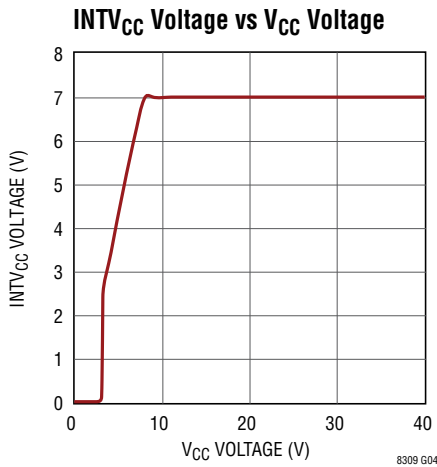
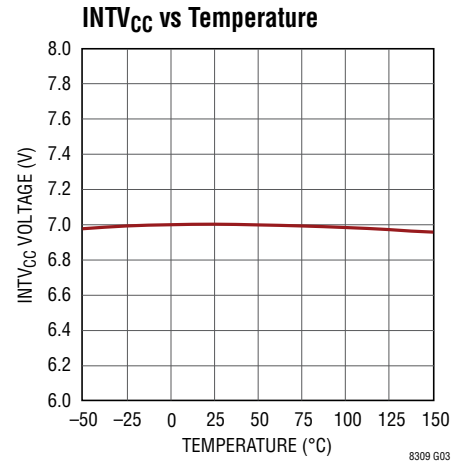
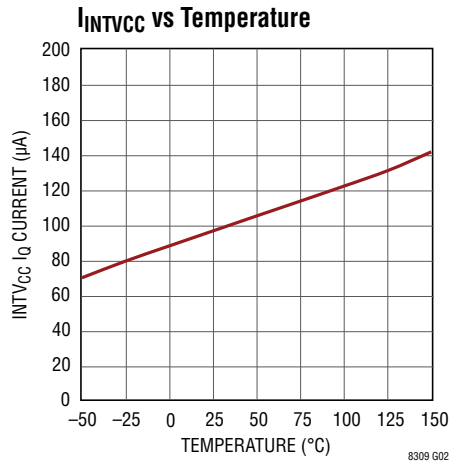
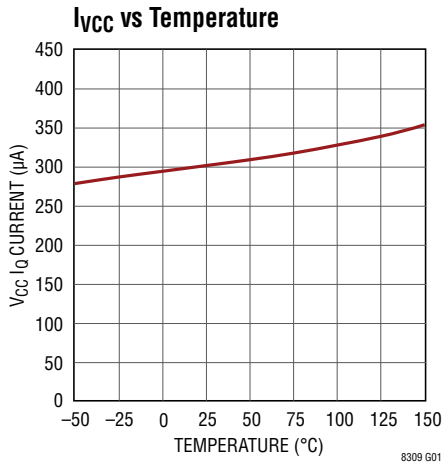

# TYPICAL PERFORMANCE CHARACTERISTICS

**DRAIN Pin Current vs Temperature**

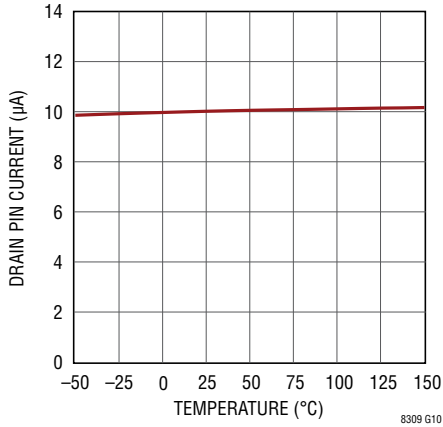

**Comparator Turn-On Threshold vs Temperature**

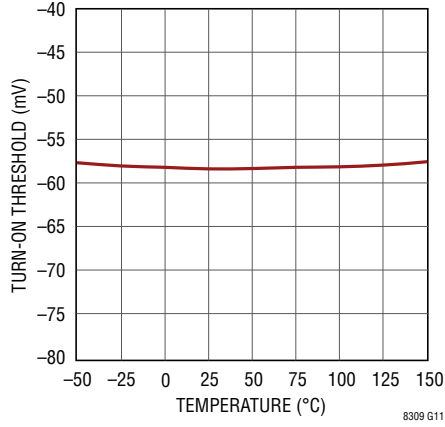

**Comparator Turn-Off Threshold vs Temperature**

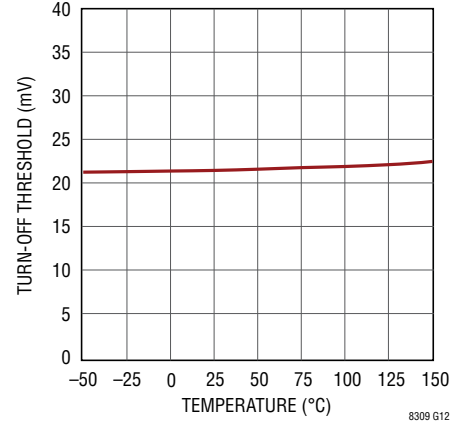

**Latch Reset Threshold vs Temperature**

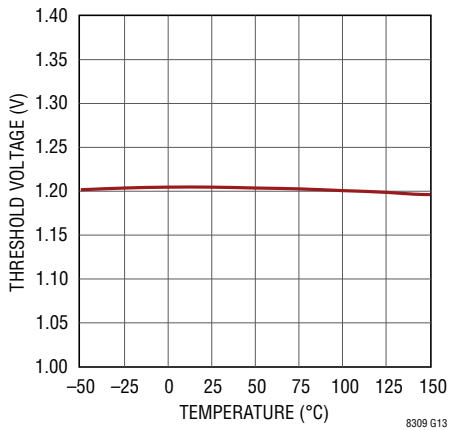

**GATE Rise and Fall Time vs Charge**

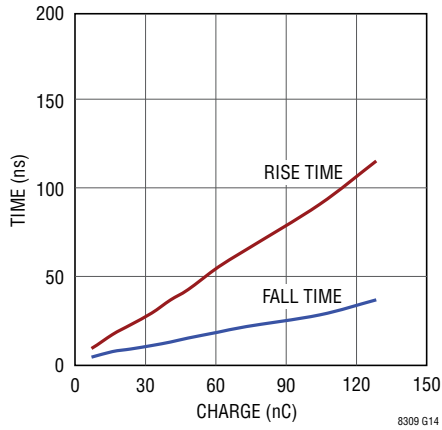

**GATE Current vs Charge**

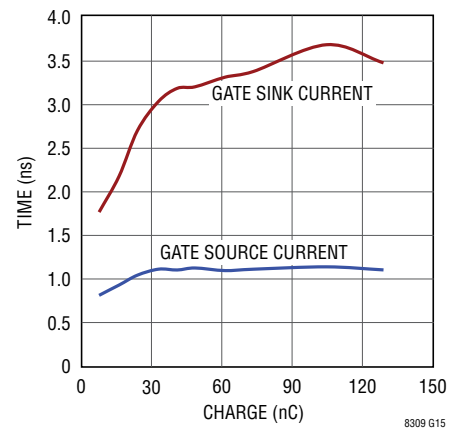

## PIN FUNCTIONS

**GATE (Pin 1):** N-Channel MOSFET Gate Driver Output. Switches between  $INTV_{CC}$  and GND. Driven to GND during undervoltage lockout of  $INTV_{CC}$ .

**GND (Pin 2):** Ground.

**$INTV_{CC}$  (Pin 3):** Regulated Supply for Internal Loads, and GATE Driver. Supplied from  $V_{CC}$  and regulates to 7V (typical).  $INTV_{CC}$  must be bypassed with a 4.7 $\mu$ F capacitor placed close to the pin.

**$V_{CC}$  (Pin 4):** Input Voltage. This pin supplies current to the internal start-up circuitry and to the  $INTV_{CC}$  LDO. This pin must be locally bypassed with a capacitor.

**DRAIN (Pin 5):** Current Sense Pin. This pin senses the voltage across the drain-to-source of the external N-channel MOSFET. A series resistor is needed to set the offset voltage and needs to be at least 800 $\Omega$ . The offset is equal to:

$$20\text{mV} \cdot \left(1 - \frac{R}{2000}\right)$$

## BLOCK DIAGRAM

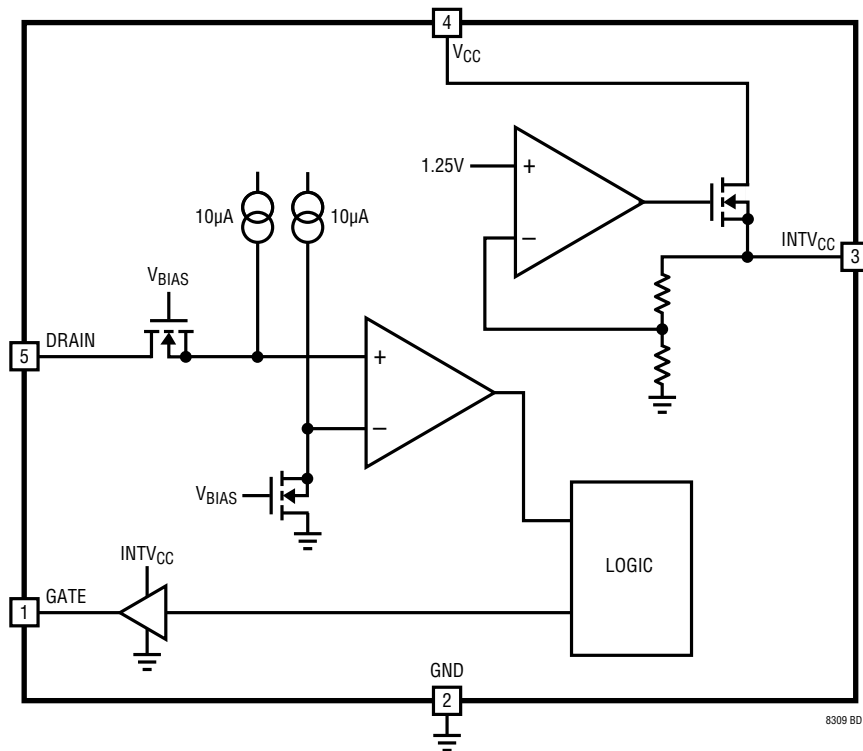

## OPERATION

The LT8309 is a synchronous rectifier designed for boundary conduction mode/critical conduction mode and discontinuous mode flyback converters. Existing solutions use a pulse signal from the primary side to control the synchronous rectifier, but the LT8309 senses the drain-source voltage of the MOSFET to control the synchronous rectifier. This technique not only eliminates a transformer, but allows it to work with Linear Technology's line of no-opto critical conduction flyback converters. Synchronous rectification improves efficiency and more importantly increases the maximum output current when compared to nonsynchronous designs.

The LT8309 imitates the behavior of a diode but replaces the forward voltage with the  $R_{DS(ON)}$  of an external N-channel MOSFET. The LT8309 includes an LDO, a very fast comparator and a powerful gate driver.

An external resistor connects the part's DRAIN pin to the drain of the MOSFET. This resistor sets the trip point of the comparator with a precise internal current source. To set the trip point to  $-10\text{mV}$ , a  $3000\Omega$  resistor is needed. The trip point decreases by  $1\text{mV}$  for every  $100\Omega$  added to this drain resistor. This trip point will be referred to as  $V_{OFFSET}$ . Figure 1 shows the drain waveform on top and the gate waveform on the bottom. The gate node goes high when the drain node goes  $74\text{mV}$  below the  $V_{OFFSET}$ . The comparator's output is ignored for a minimum on-time to eliminate the chance that ringing triggers the comparator. After the minimum on-time, the comparator is ready to trigger at the  $V_{OFFSET}$  voltage. Once the drain voltage goes above  $V_{OFFSET}$ , the gate turns off after a very fast propagation delay,  $t_{D(OFF)}$ . The body diode begins to conduct again before the current reaches  $0\text{A}$ . The drain voltage needs to go above  $1.21\text{V}$  and then wait for the minimum off-time before the comparator is re-enabled.

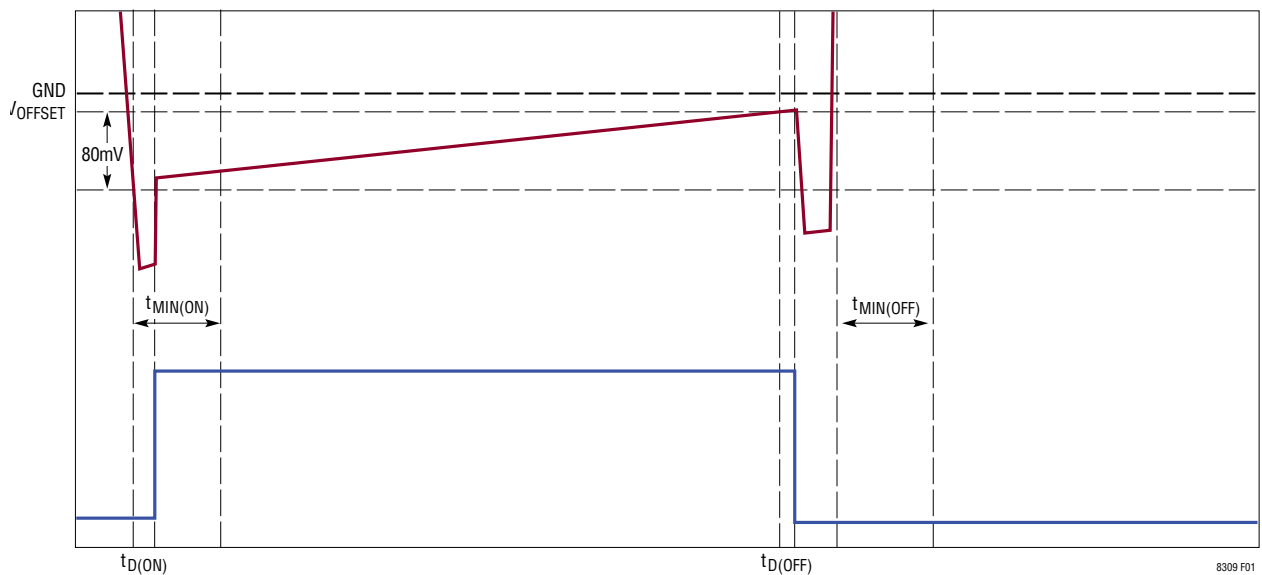

Figure 1. Drain and Gate Waveforms

## OPERATION

### Undervoltage Lockout

The part features a  $INTV_{CC}$  undervoltage lockout (UVLO) to prevent switching until the  $INTV_{CC}$  voltage is above 4V.

### $INTV_{CC}$ LDO

An internal LDO regulator provides a regulated 7V output from the  $V_{IN}$  pin to the  $INTV_{CC}$  pin. An output capacitor is needed to provide the current needed for the gate driver. A 4.7 $\mu$ F capacitor is recommended and must be placed as close as possible to the  $INTV_{CC}$  pin. The current limit for the LDO is 42mA.

### MOSFET Selection

A MOSFET's  $R_{DS(ON)}$  is important to the operation of the LT8309. The drain-source voltage is used to determine when to turn off the MOSFET. The peak current through the MOSFET times the MOSFET's  $R_{DS(ON)}$  should be above 75mV. When this voltage is too low, the high speed comparator may trip early due to ringing on the DRAIN pin. When this voltage is too high, the MOSFET dissipates a large amount of power which causes efficiency to go down and may cause thermal issues with the MOSFET.

### Setting the DRAIN Pin Resistor

The DRAIN pin resistor sets when the LT8309 turns off the MOSFET. The trip point,  $V_{OFFSET}$ , is set with the following equation:

$$V_{OFFSET} = 20mV - 10\mu A \cdot R_{DRAIN}$$

$R_{DRAIN}$  is the resistor connected between the drain of the MOSFET and the DRAIN pin of the part.  $R_{DRAIN}$  needs to be at least 800 $\Omega$  to operate correctly. For most applications,  $V_{OFFSET}$  should be set at -5mV. High  $R_{DS(ON)}$  MOSFETs may require a more negative  $V_{OFFSET}$  voltage to keep the drain-to-source current from reversing. If the current is reversing, decrease  $V_{OFFSET}$  in 5mV steps to eliminate the cross-conduction.

### Short-Circuit Operation

In the Typical Application diagram on Page 1, the  $V_{CC}$  pin is connected to the output of the flyback converter. During an output short-circuit condition, the LT8309 is off and the body diode of the MOSFET must handle the short-circuit condition. This puts additional thermal requirements on the MOSFET. The drain voltage of the MOSFET is equal to  $V_{IN}/N$  in short-circuit and capable of powering the LT8309 with the circuit in Figure 2. This allows the LT8309

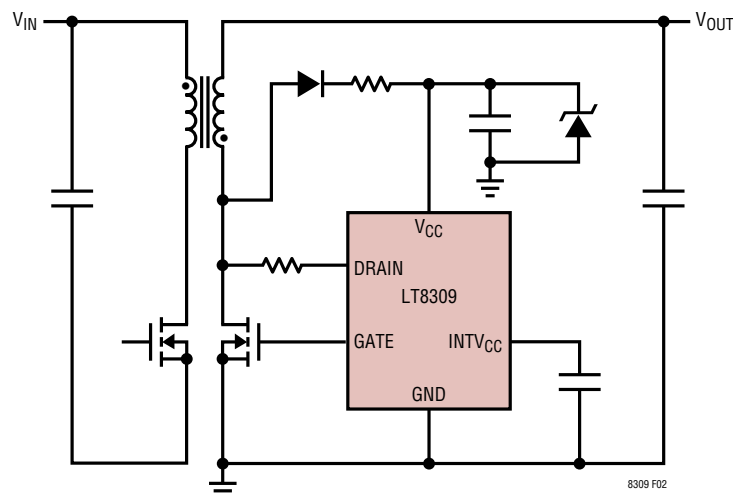

Figure 2. Short-Circuit Application Circuit



## OPERATION

to operate during a short, and the current will flow through the low resistance channel of the MOSFET instead of its body diode. Make sure to use a resistor in series with the diode to keep  $V_{CC}$  below 40V.

### Layout Considerations

The main current loop is the MOSFETs drain-to-source current. This should not share the same ground path as the LT8309. The drain resistor needs to sense directly at the drain of the MOSFET and not have any current of the drain current flow through its metal trace. The drain node of the MOSFET is used as the heat sink and will need to be sized according to the power dissipation requirements. Figure 3 is an example layout of the LT8309.

### Effects of the Body Diode

When the discontinuous ring voltage goes below ground, the body diode of the primary-side MOSFET turns on and begins to conduct current. This diode clamps the voltage

to a diode drop below ground. When the current reverses direction, the diode does not turn off immediately, and conducts current in the opposite direction for a small period of time. This is known as the reverse-recovery time. During this time, the magnetizing inductance of the transformer stores energy just like it does when the MOSFET turns on. When the primary-side body diode finally turns off, the energy is transferred to the secondary side and may be enough to turn on the body diode of the secondary MOSFET. Then, the LT8309 turns on its MOSFET for a second time. Since this happens during the discontinuous ring, the primary side may turn on during this time and cause cross conduction. If this problem does occur, one way to improve the reverse-recovery time of the primary side's MOSFET is to add a parallel Schottky diode, which will conduct most of the current and turn off much faster than the body diode. Another way of eliminating this issue is by sizing the turns ratio so that the discontinuous ring never goes below ground.

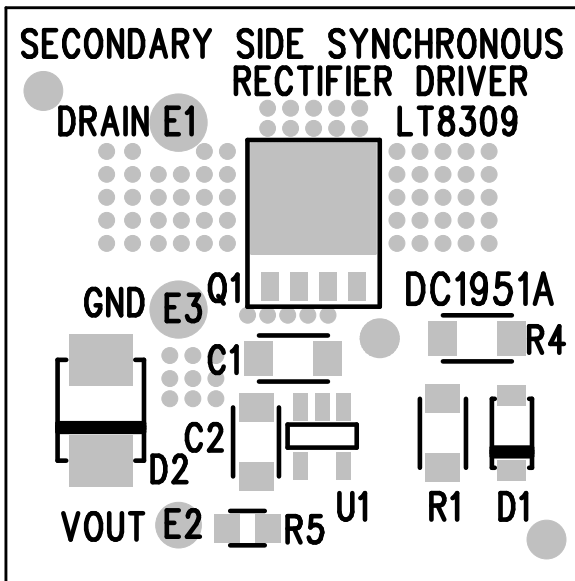

Figure 3. Demo Board Topside Silkscreen

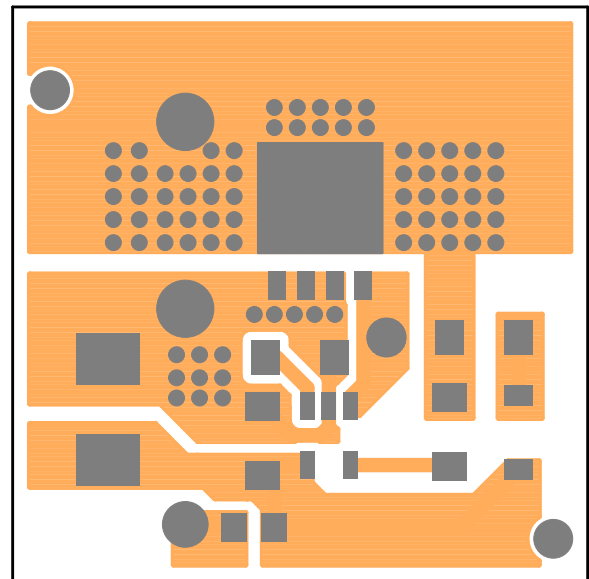
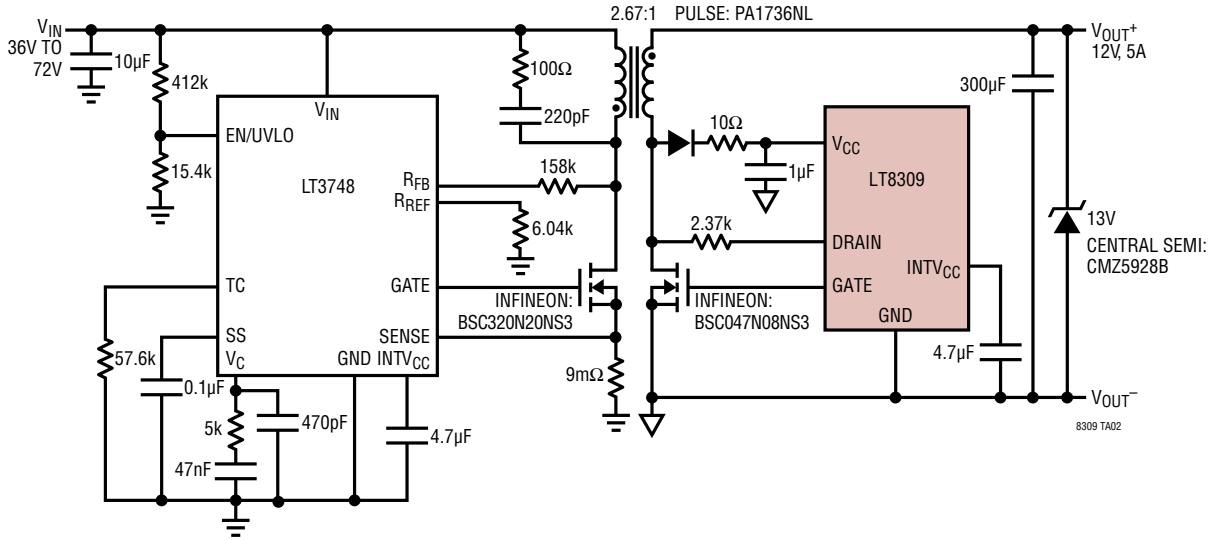

Figure 4. Demo Board Topside Metal

TYPICAL APPLICATIONS

60W, 12V Output, Isolated Telecom Supply



TYPICAL APPLICATIONS

40W, 5V Isolated Telecom Supply

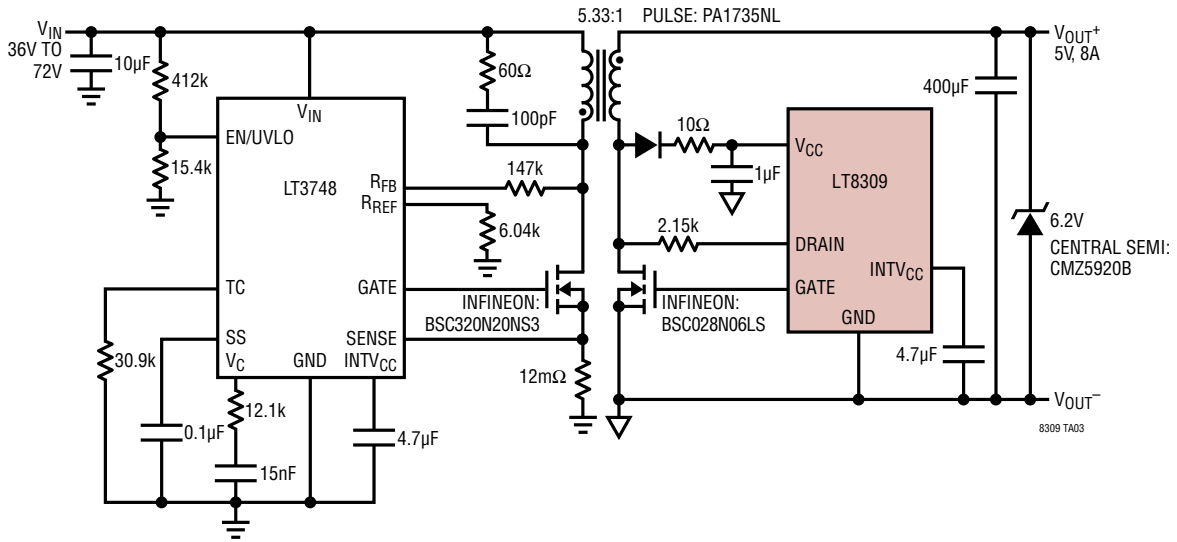

# PACKAGE DESCRIPTION

Please refer to <http://www.linear.com/designtools/packaging/> for the most recent package drawings.

## S5 Package 3-Lead Plastic TSOT-23 (Reference LTC DWG # 05-08-1635)

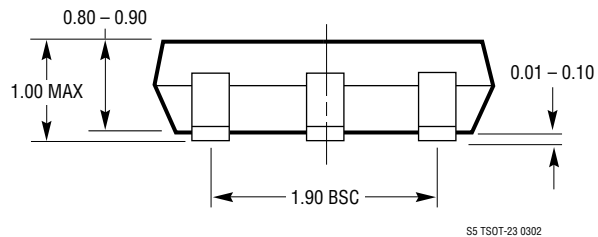
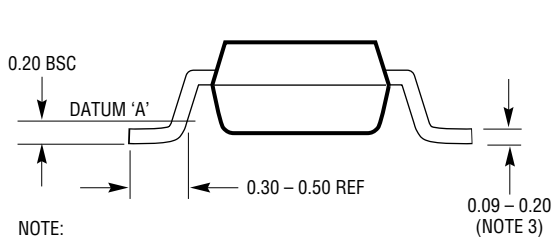
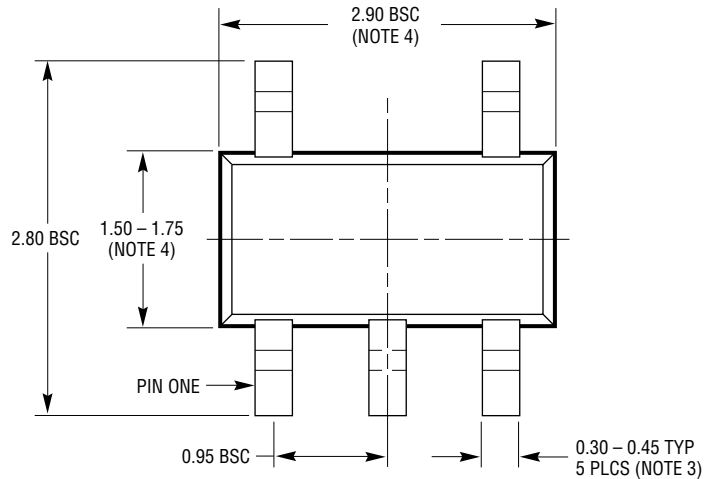
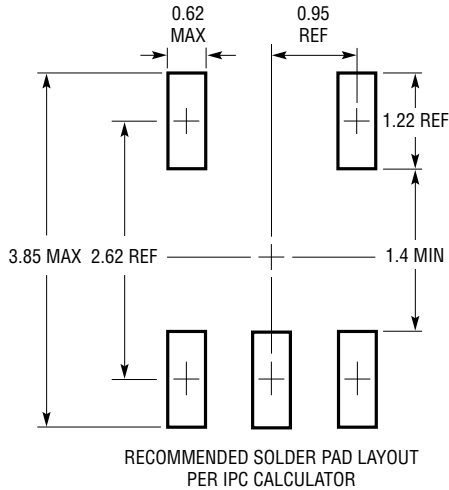

- NOTE:
1. DIMENSIONS ARE IN MILLIMETERS
  2. DRAWING NOT TO SCALE
  3. DIMENSIONS ARE INCLUSIVE OF PLATING
  4. DIMENSIONS ARE EXCLUSIVE OF MOLD FLASH AND METAL BURR
  5. MOLD FLASH SHALL NOT EXCEED 0.254mm
  6. JEDEC PACKAGE REFERENCE IS MO-193

S5 TSOT-23 0302

## REVISION HISTORY

REV	DATE	DESCRIPTION	PAGE NUMBER
A	11/14	Added H-Grade Version	2, 3

TYPICAL APPLICATION

33W, 3.3V Isolated Telecom Supply

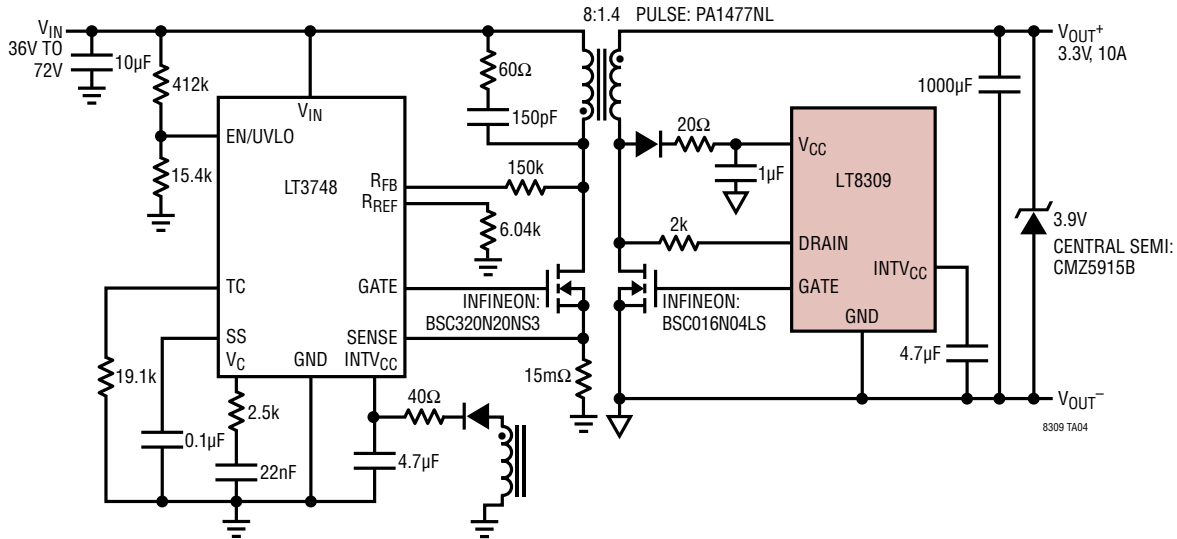

RELATED PARTS

PART NUMBER	DESCRIPTION	COMMENTS
<a href="#">LT3748</a>	100V Isolated Flyback Controller	$5V \leq V_{IN} \leq 100V$ , No-Opto Flyback, MSOP-16 Package
<a href="#">LT3798</a>	Offline Isolated No-Opto-Coupler Flyback Controller with Active PFC	$V_{IN}$ and $V_{OUT}$ Limited Only by External Components, MSOP-16 Package
<a href="#">LT3799/LT3799-1</a>	Offline Isolated Flyback LED Controller with Active PFC	$V_{IN}$ and $V_{OUT}$ Limited Only by External Components, MSOP-16 Package
<a href="#">LT3957A/LT3958</a>	40V/80V Flyback/Boost/Inverting/SEPIC Converter	Monolithic with Integrated 5A/3.3A Switch
<a href="#">LT3573/LT3574/LT3575</a>	40V Isolated Flyback Converters	Monolithic No-Opto Flybacks with Integrated 1.25A/0.65A/2.5A Switch
<a href="#">LT3757A/LT3759/LT3758</a>	40V/100V Boost, Flyback, SEPIC and Inverting Controllers	Universal Controllers with Small Package and Powerful Gate Drive
<a href="#">LT8302</a>	Micropower No-Opto Isolated Flyback Converter	$2.8V \leq V_{IN} \leq 42V$ , with Integrated 3.6A, 65V DMOS Power Switch, 106µA Quiescent Current, SO-8 Package

## X-ON Electronics

Largest Supplier of Electrical and Electronic Components

*Click to view similar products for [Switching Voltage Regulators](#) category:*

*Click to view products by [Analog Devices](#) manufacturer:*

Other Similar products are found below :

[TLF30682QVS01XUMA1](#) [LMR33620CRNXR](#) [TPSM84209RKHR](#) [FAN53526UC106X](#) [FAN53526UC128X](#) [FAN53611AUC123X](#)  
[MP1587EN-LF](#) [AP3602AKTR-G1](#) [FAN48610BUC33X](#) [FAN48617UC50X](#) [FAN53526UC89X](#) [MIC45116-1YMP-T1](#) [MP2225GJ-P](#)  
[NCV891234MW50R2G](#) [A6986F5VTR](#) [AST1S31PUR](#) [SIC473ED-T1-GE3](#) [16017](#) [A6986FTR](#) [NCP81103MNTXG](#) [NCP81203PMNTXG](#)  
[MAX17242ETPA+](#) [MAX16935RATEB/V+](#) [MP2313GJ-Z](#) [NCP81208MNTXG](#) [MP8759GD-Z](#) [FAN53526UC84X](#) [PCA9412AUKZ](#)  
[MP2314SGJ-Z](#) [AS1340A-BTDM-10](#) [MP3421GG-P](#) [NCP81109GMNTXG](#) [NCP3235MNTXG](#) [MP6003DN-LF-Z](#) [MAX16935BAUES/V+](#)  
[LT8315IFE#PBF](#) [SCY1751FCCT1G](#) [NCP81109JMNTXG](#) [MAX16956AUBA/V+](#) [AP3409ADNTR-G1](#) [SIC474ED-T1-GE3](#) [A6986F3V3TR](#)  
[MPQ2454GH](#) [MPQ2454GH-AEC1](#) [MP21148GQD-P](#) [AS3701B-BWLM-68](#) [SC21150ACSTRT](#) [MPQ2143DJ-P](#) [MP9942AGJ-P](#) [MP8869GL-](#)  
[P](#)