

LOC	DIST	REVISIONS					
		P	LTN	DESCRIPTION	DATE	DWN	APVD
GP	00	G1		REVISED PER ECO-11-016901	05APR2012	KH	AS
		G2		ADD MODULE EXTRACTION GUIDE	10JUL2012	AY	SZ

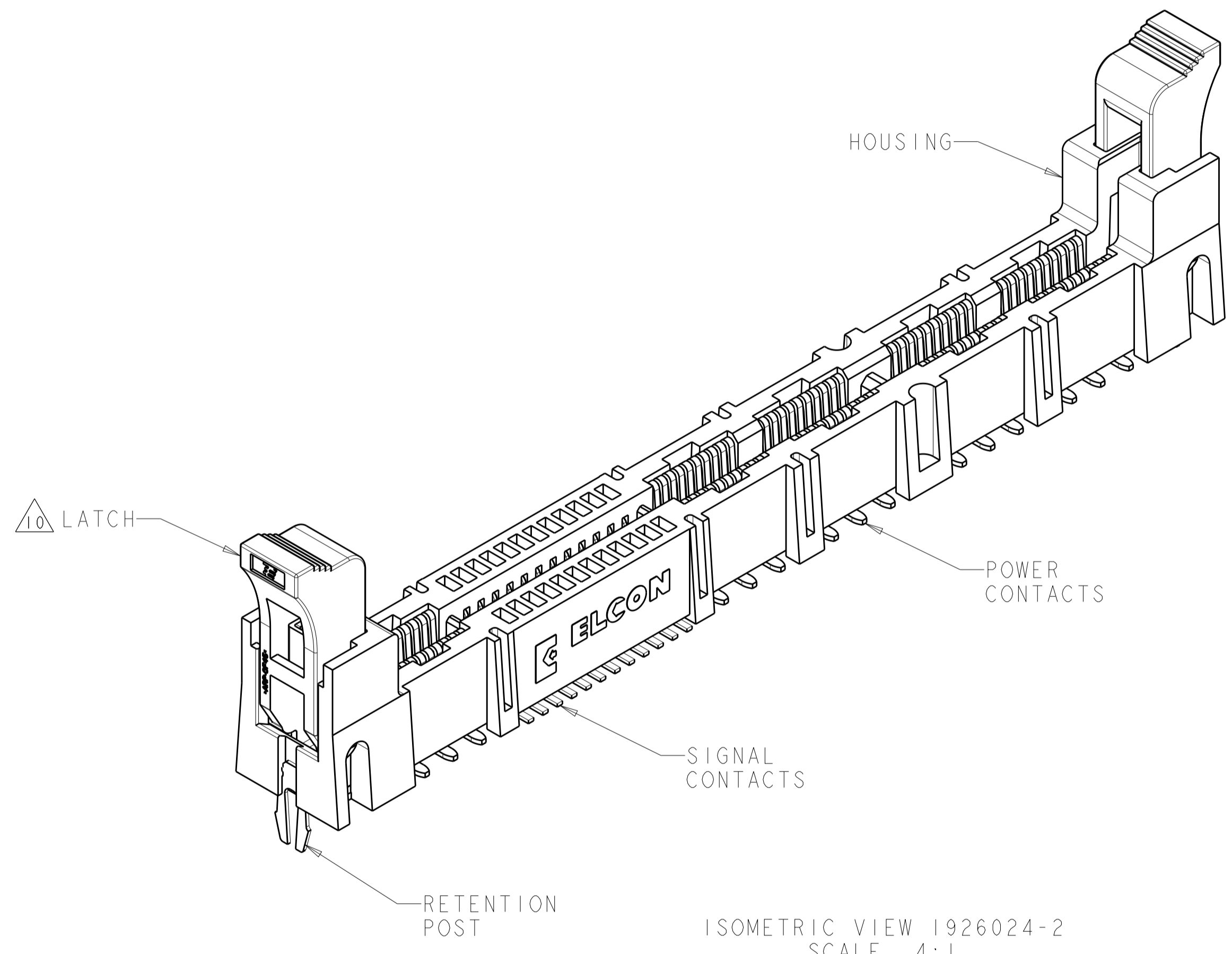

ISOMETRIC VIEW 1926024-2
 SCALE 4:1

1. PART NUMBER CHANGES AND OR DESIGN CHANGES AFFECTING ITEM INTERCHANGEABILITY REQUIRE PRIOR TYCO ELECTRONICS APPROVAL AND AUTHORIZATION BY REVISION TO THIS DRAWING.

2. MATERIAL:
 HOUSING: GLASS FILLED POLYESTER, COLOR-BLACK
 UL94V-0 FLAMMABILITY RATED
 LATCHES: THERMOPLASTIC, GLASS REINFORCED
 COLOR: BLACK, UL94V-0 FLAMMABILITY RATED
 CONTACTS: COPPER ALLOY
 RETENTION POST: COPPER ALLOY

3. FINISH:
 SIGNAL CONTACTS:
 MATING AREA-0.76µm MIN GOLD OVER 3.81µm MIN NICKEL
 0.64µm MIN NICKEL PLATE OVER REMAINDER
 SMT TAILS-3.81µm MIN MATTE TIN OVER NICKEL PLATE
 POWER CONTACTS:
 1.27µm MIN NICKEL PLATE ALL OVER
 MATING AREA-0.76µm MIN GOLD OVER NICKEL PLATE
 SMT TAILS-3.05µm MIN TIN OVER NICKEL PLATE
 RETENTION POSTS:
 3.05µm MIN MATTE TIN OVER 0.63µm MIN NICKEL

4. ITEMS PROVIDED TO THIS SPECIFICATION TO BE PERMANENTLY IDENTIFIED WITH PART NUMBER AND DATE CODE.

5. MAXIMUM BURR OF 0.013 ON CARD TAB AREA.

6. SET TRACE BACK FROM PC BOARD EDGE. NO SOLDERMASK ALLOWED BETWEEN PC BOARD EDGE AND TRACE.

7. CONNECTOR ACCEPTS 1.57±0.13 THICK PC BOARD.

8. KEEP OUT AREA FOR COMPONENTS ONLY.

9. FEATURE REQUIRED FOR USE WITH EJECTOR.

10. CAUTION:
 LATCHES ARE INTENDED FOR RETENTION OF PC BOARD TO CONNECTOR. DO NOT ATTEMPT TO FULLY EJECT PC BOARD FROM CONNECTOR WHILE DISENGAGING LATCHES, DAMAGE TO LATCHES AND OR CONNECTOR MAY OCCUR.

11. RECOMMENDED GOLD FINGER LENGTH FOR RELIABLE CONTACT.

12. DATUMS AND BASIC DIMENSIONS ESTABLISHED BY CUSTOMER.

13. FOR DESIGN OBJECTIVES SEE 108-2301.

4.61	1926024-4
4.19	1926024-3
3.68	1926024-2
DIM. "A"	PART NUMBER

THIS DRAWING IS A CONTROLLED DOCUMENT.		DWN: N REESER 18JAN2006	
DIMENSIONS: mm		CHK: P D'AMATO 29 AUG 07	
TOLERANCES UNLESS OTHERWISE SPECIFIED:		APVD: N REESER 18JAN2006	NAME: SOCKET CONNECTOR WITH LATCH, SMT P2-S24-P8 MINI CROWN EDGE
0 PLC ±.5	1 PLC ±.5	PRODUCT SPEC	SIZE: A1
2 PLC ±.25	3 PLC ±.25	APPLICATION SPEC	CAGE CODE: 1926024
4 PLC ±.25	ANGLES ±.2	WEIGHT	RESTRICTED TO
MATERIAL:	FINISH:	CUSTOMER DRAWING	SCALE: 1:1 SHEET 1 OF 5 REV: G2

LOC	DIST	REVISIONS					
GP	00	P	LTN	DESCRIPTION	DATE	DNW	APVD
-	-	-	-	SEE SHEET 1	-	-	-

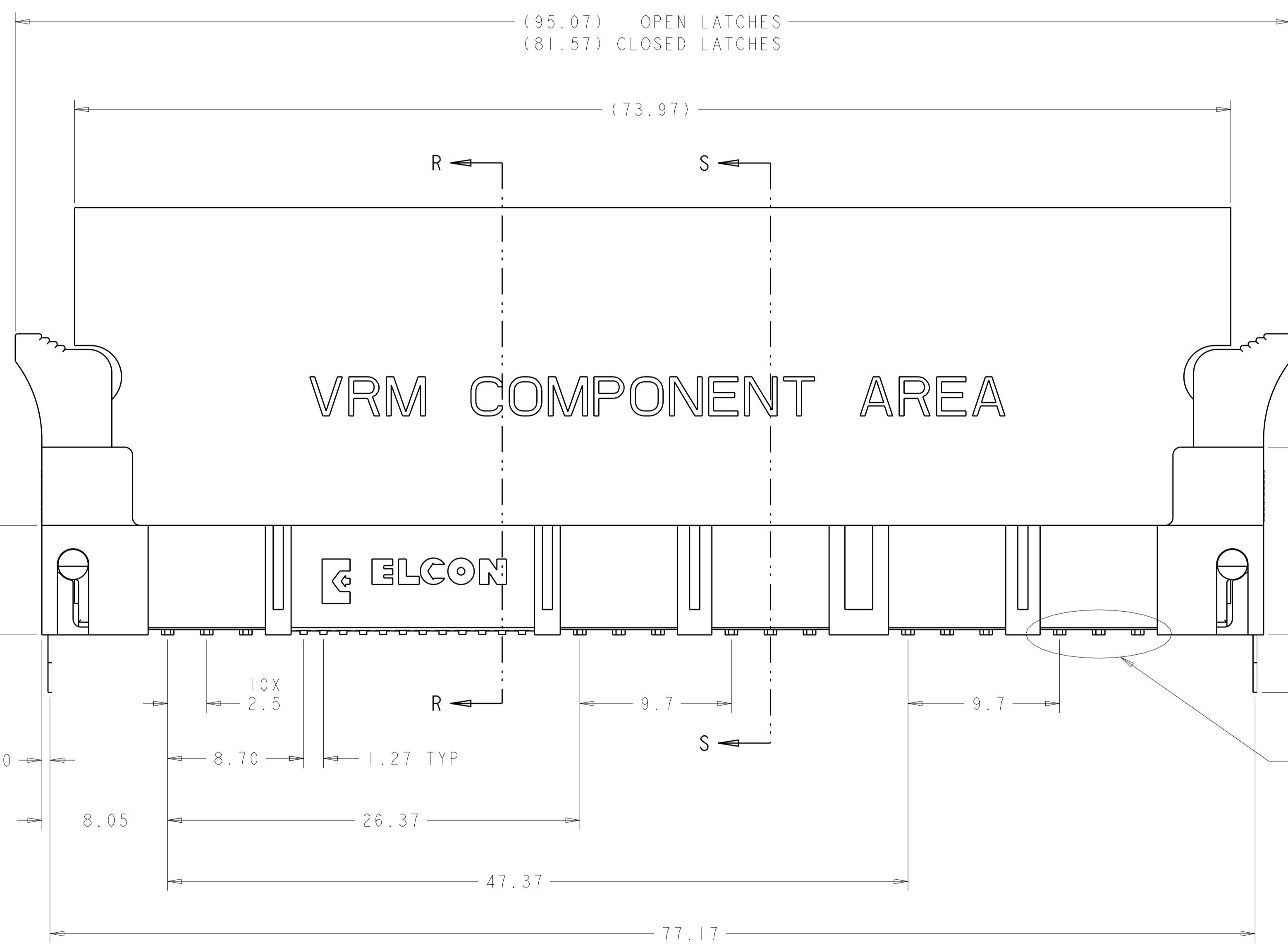
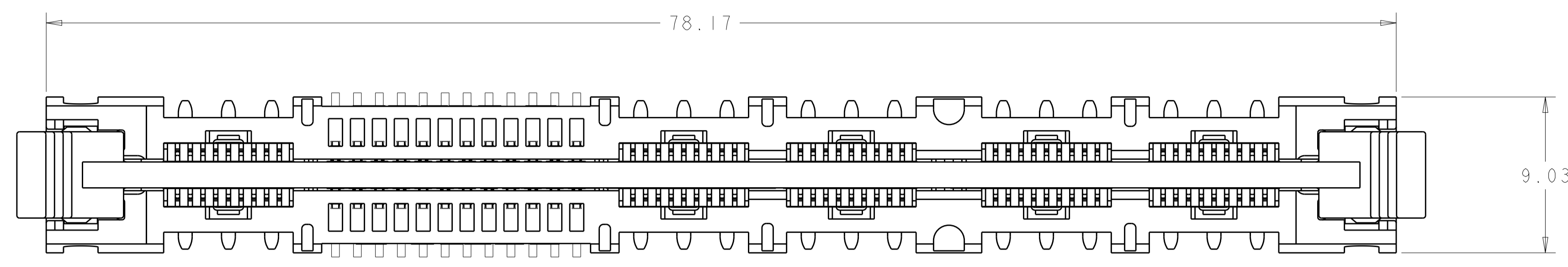

VRM COMPONENT AREA

ELCON

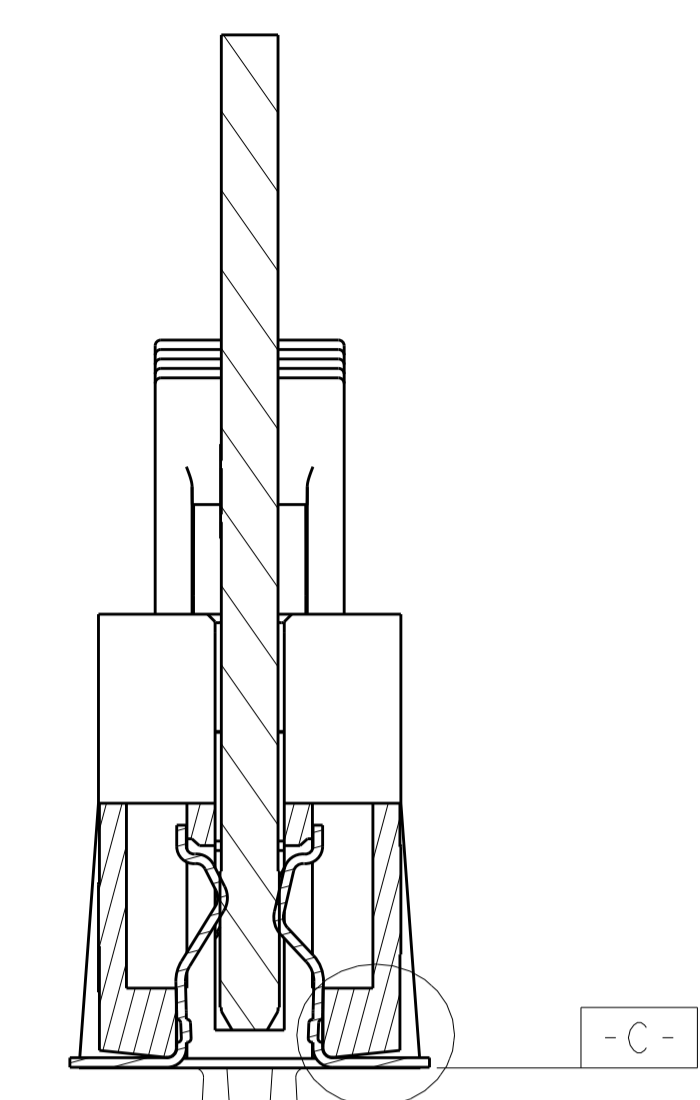

SECTION R-R

SEE DETAIL H

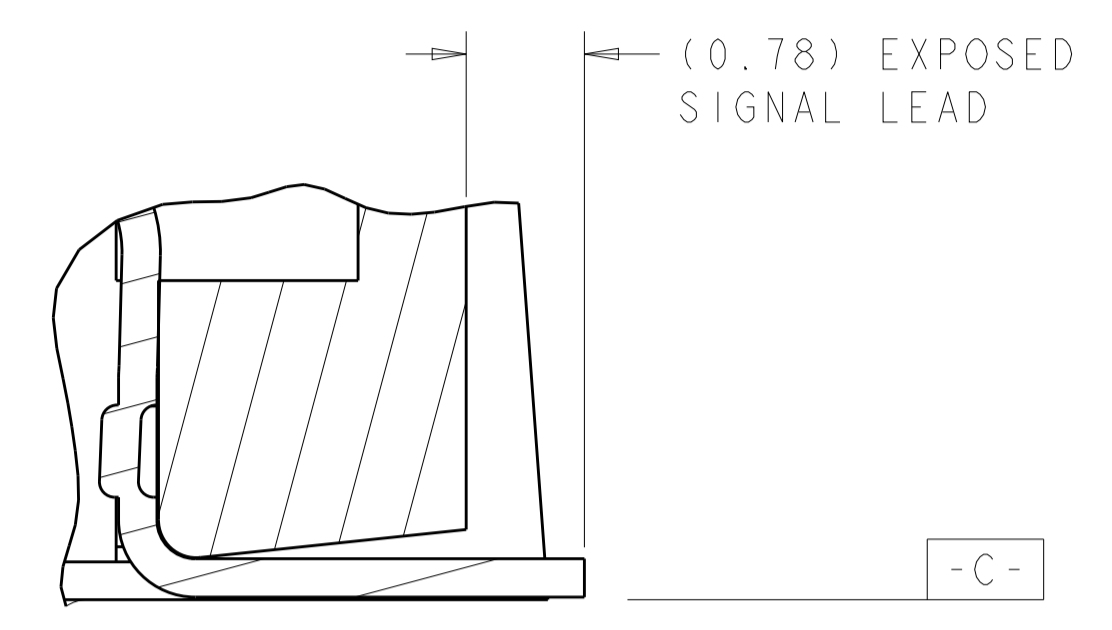

DETAIL H
SCALE 20:1

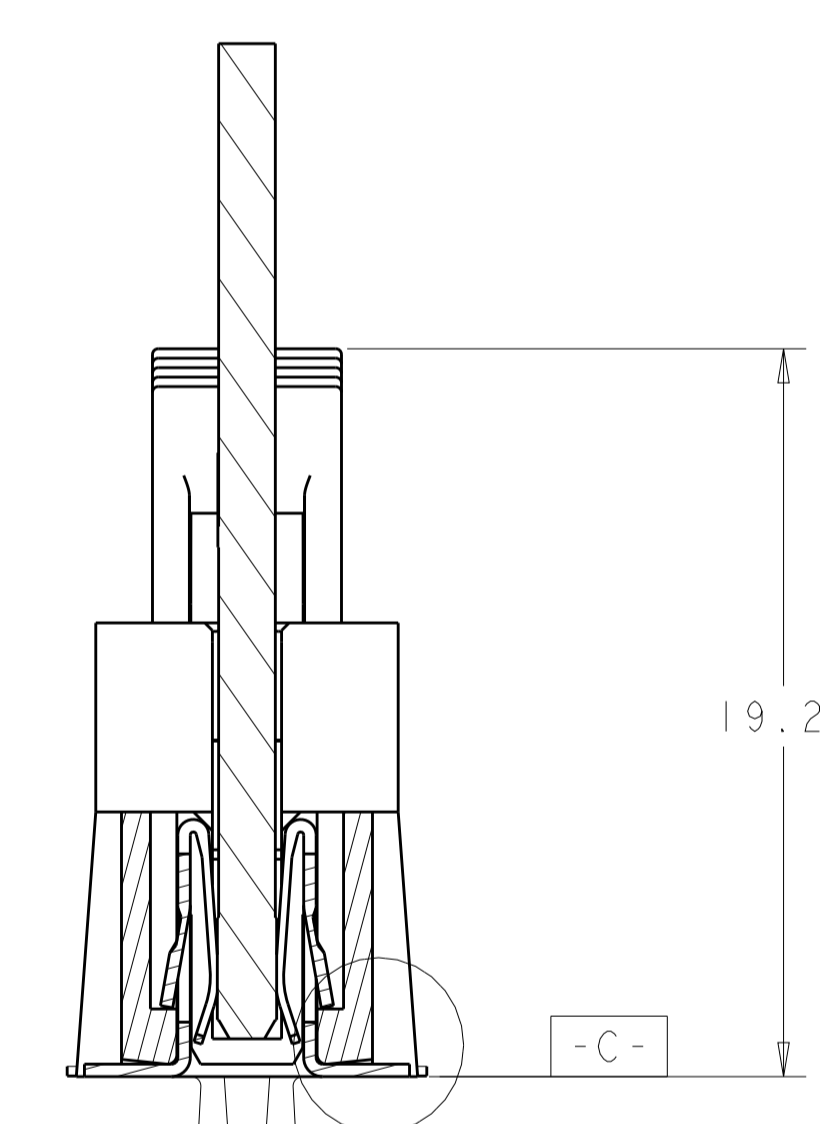

SECTION S-S

SEE DETAIL G

19.25

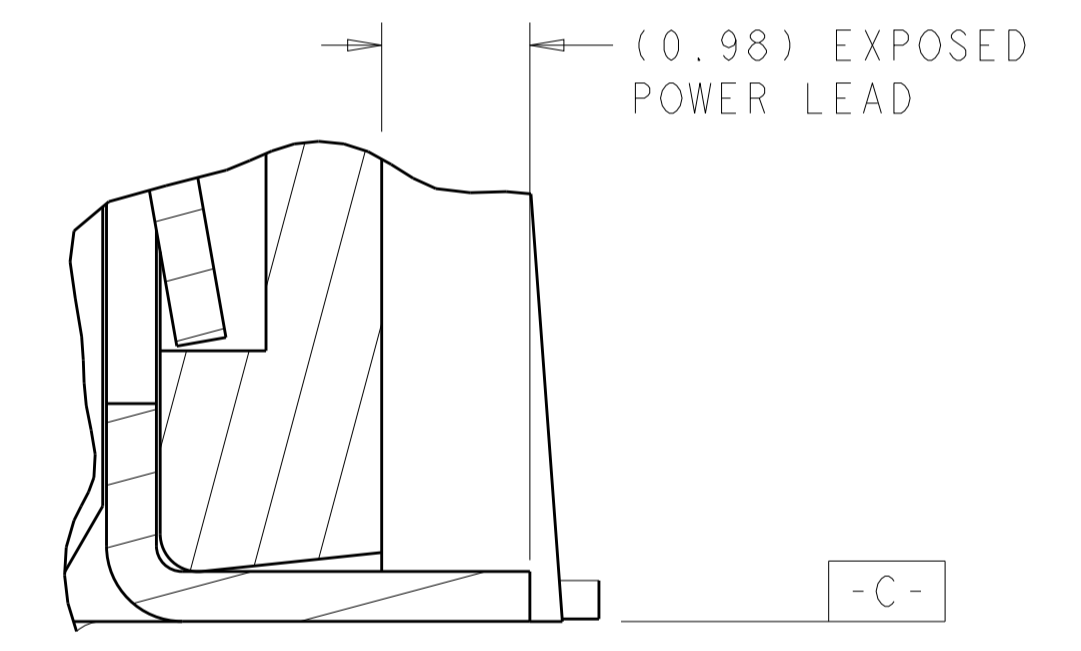

DETAIL G
SCALE 20:1

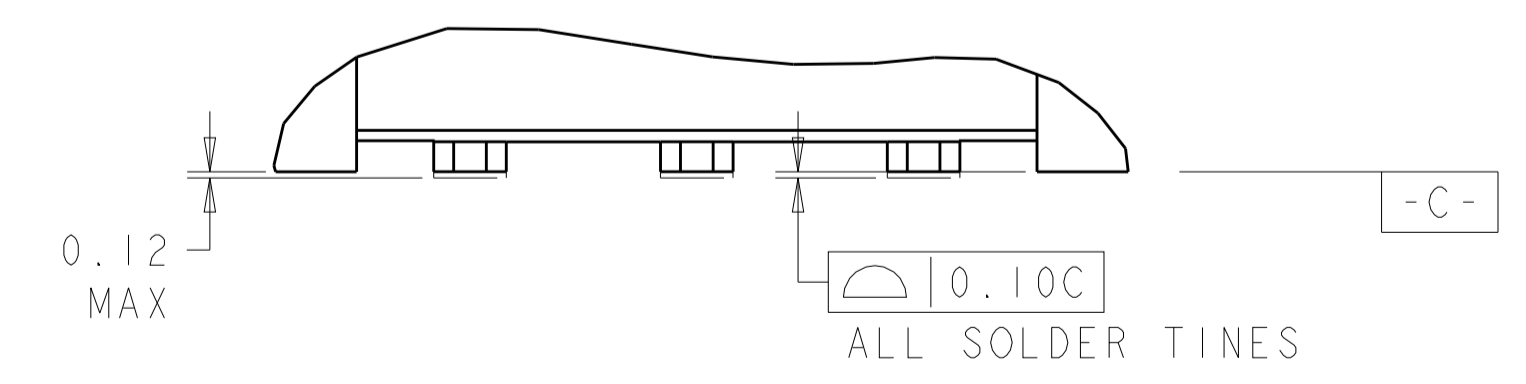

DETAIL Z
SCALE 12:1

THIS DRAWING IS A CONTROLLED DOCUMENT.		DNW N. REESER 18JAN2006	TE Connectivity
DIMENSIONS:		CHK P. D'AMATO 29 AUG 07	
mm	TOLERANCES UNLESS OTHERWISE SPECIFIED:	APVD N. REESER 18JAN2006	NAME SOCKET CONNECTOR WITH LATCH, SMT P2-S24-P8 MINI CROWN EDGE
0 PLC ±.5	1 PLC ±.5	PRODUCT SPEC	SIZE CAGE CODE DRAWING NO
2 PLC ±.25	3 PLC ±.25	APPLICATION SPEC	A100779C=1926024
4 PLC ±.	ANGLES ±.2	WEIGHT	RESTRICTED TO
MATERIAL	FINISH	CUSTOMER DRAWING	SCALE 1:1 SHEET 2 OF 5 REV G2

LOC	DIST	REV	DATE	BY	APPV
GP	00				

REVISIONS			
NO.	DESCRIPTION	DATE	BY
-	SEE SHEET 1	-	-

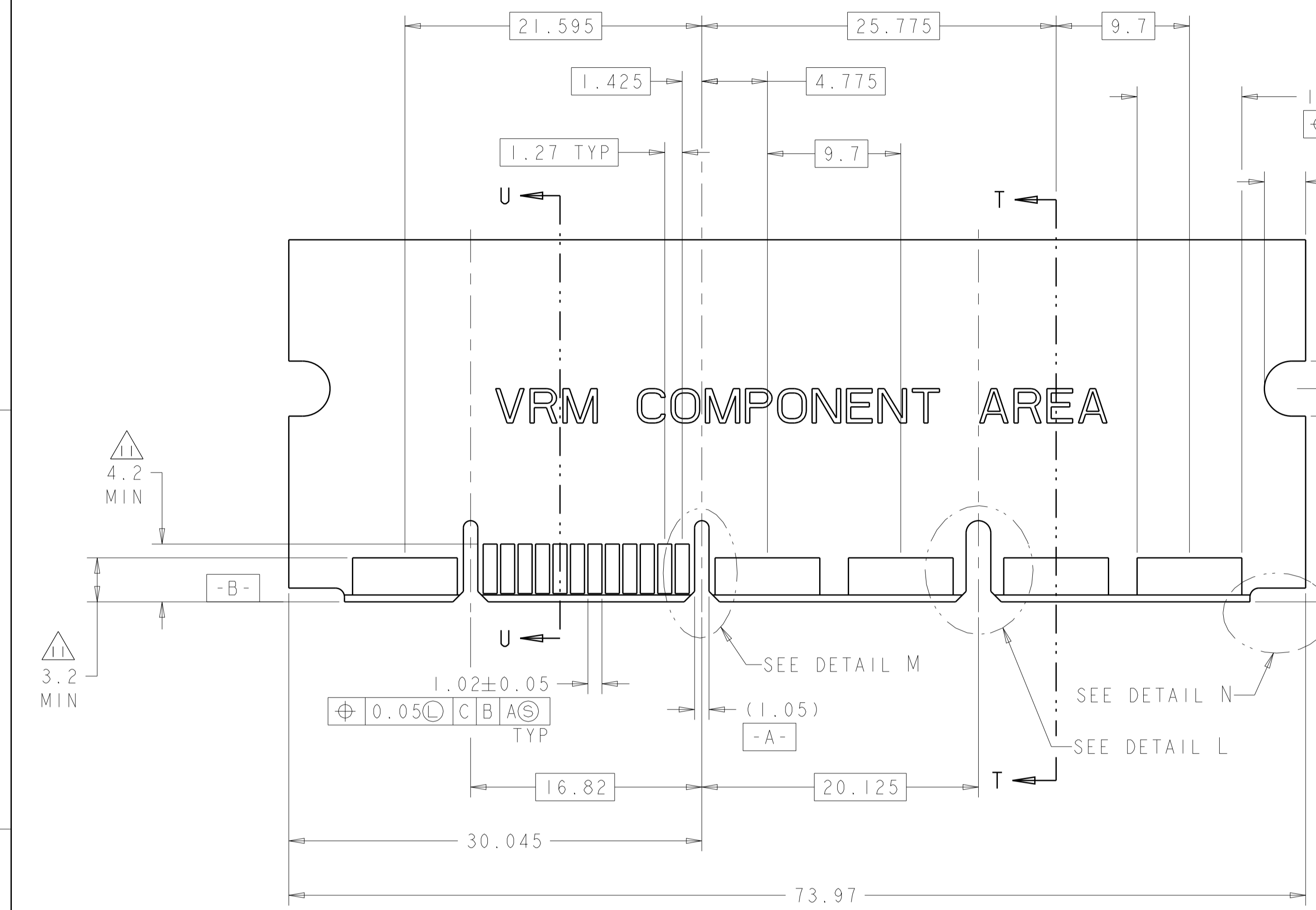

RECOMMENDED MATING BOARD SCALE 4:1

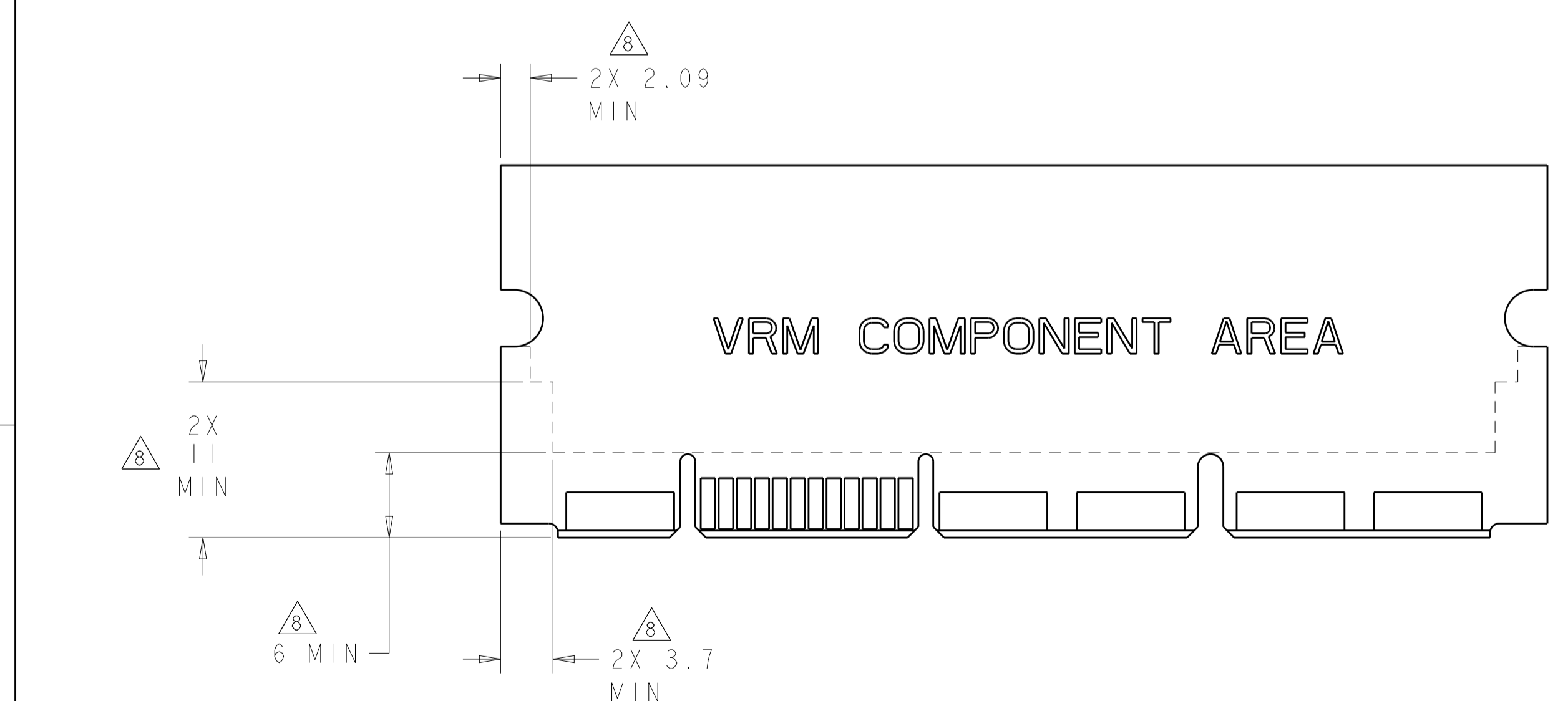

RECOMMENDED PC BOARD KEEP OUT AREA SCALE 3:1

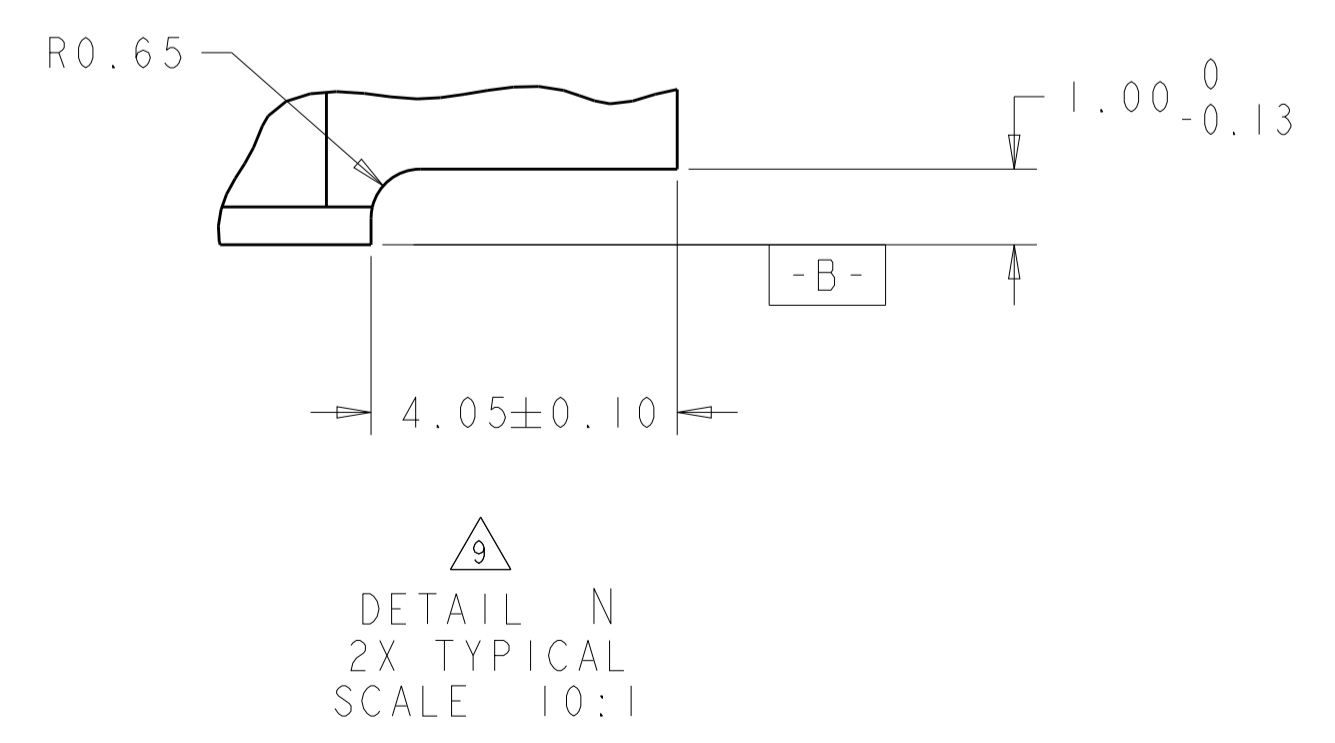
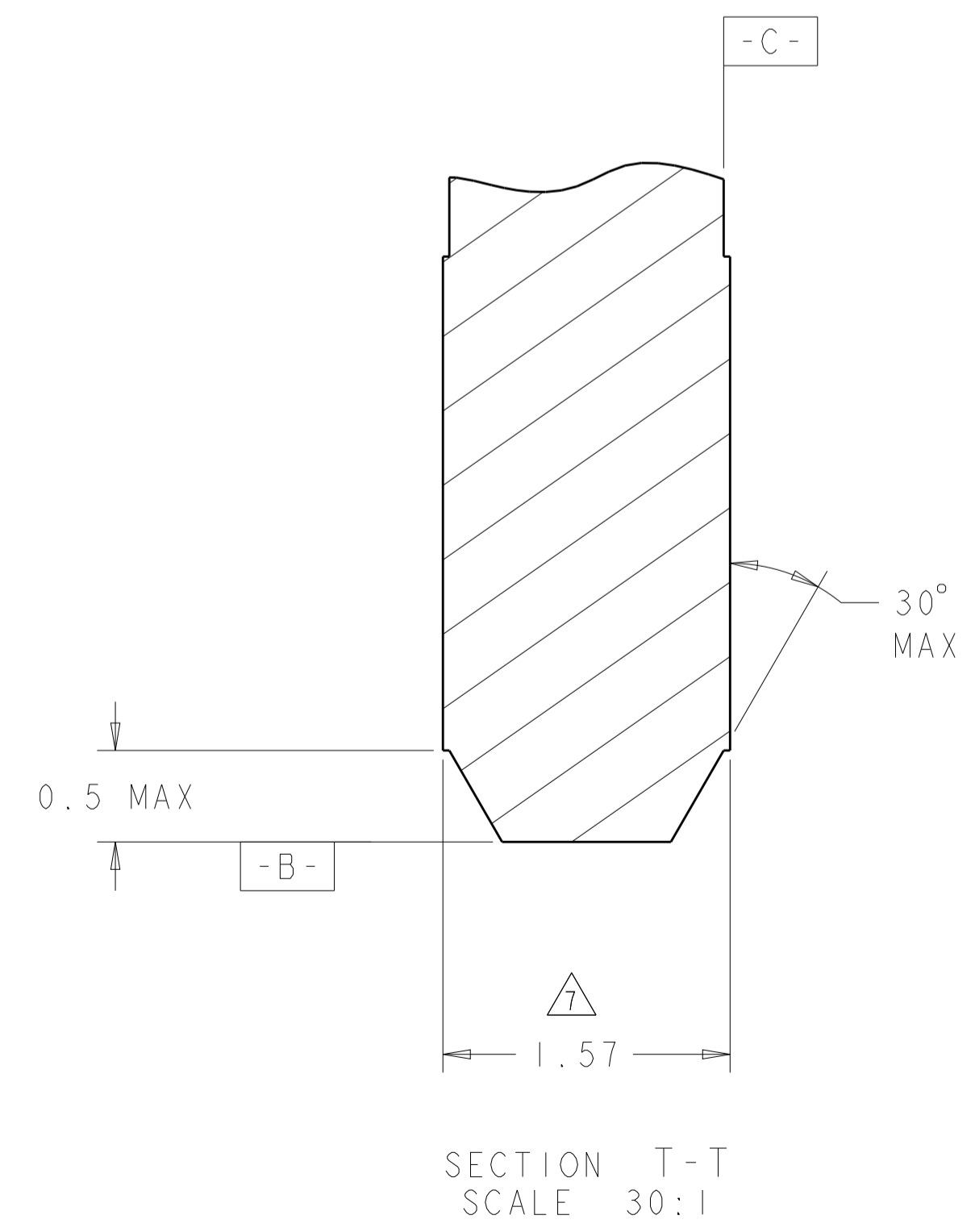
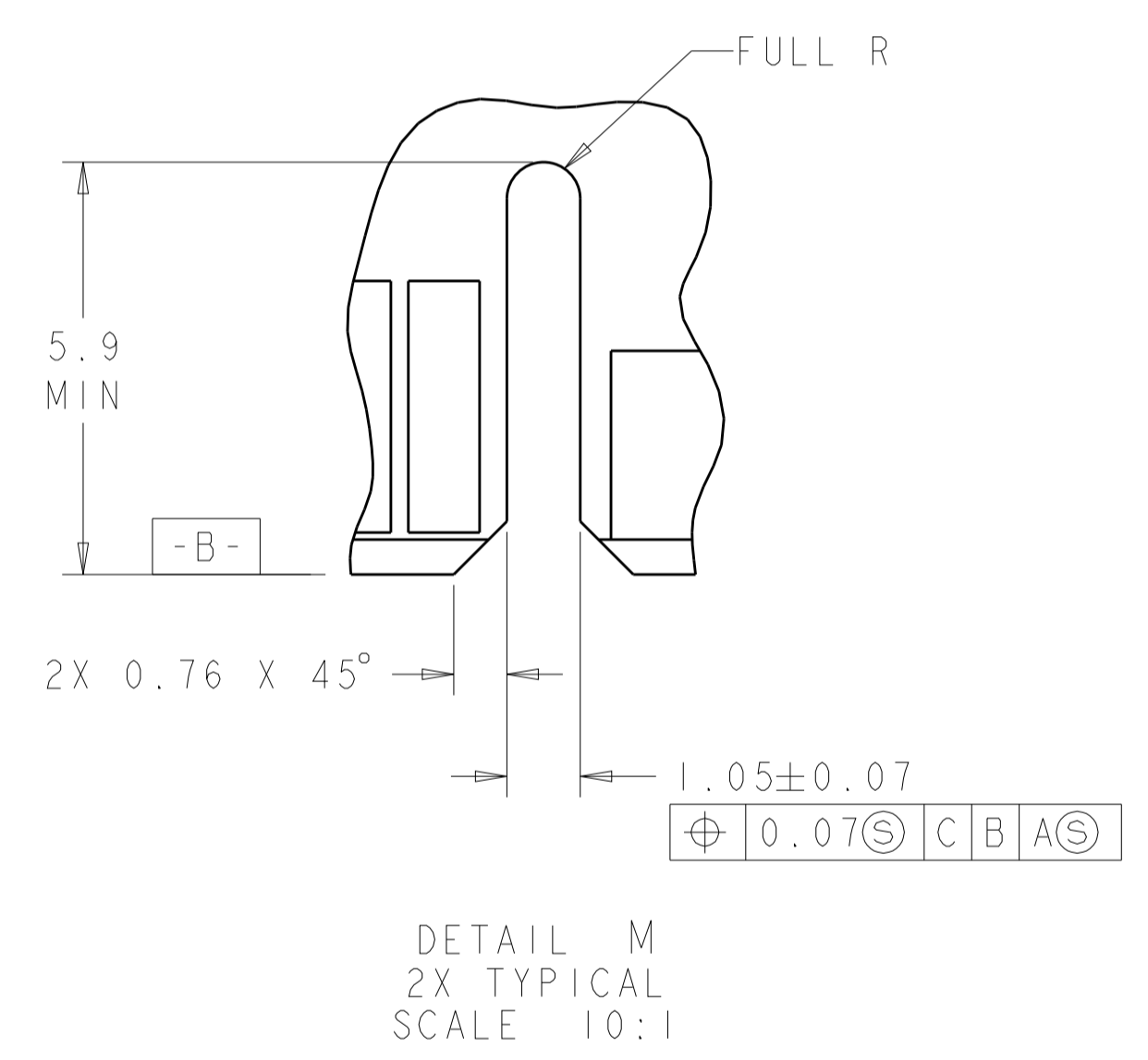
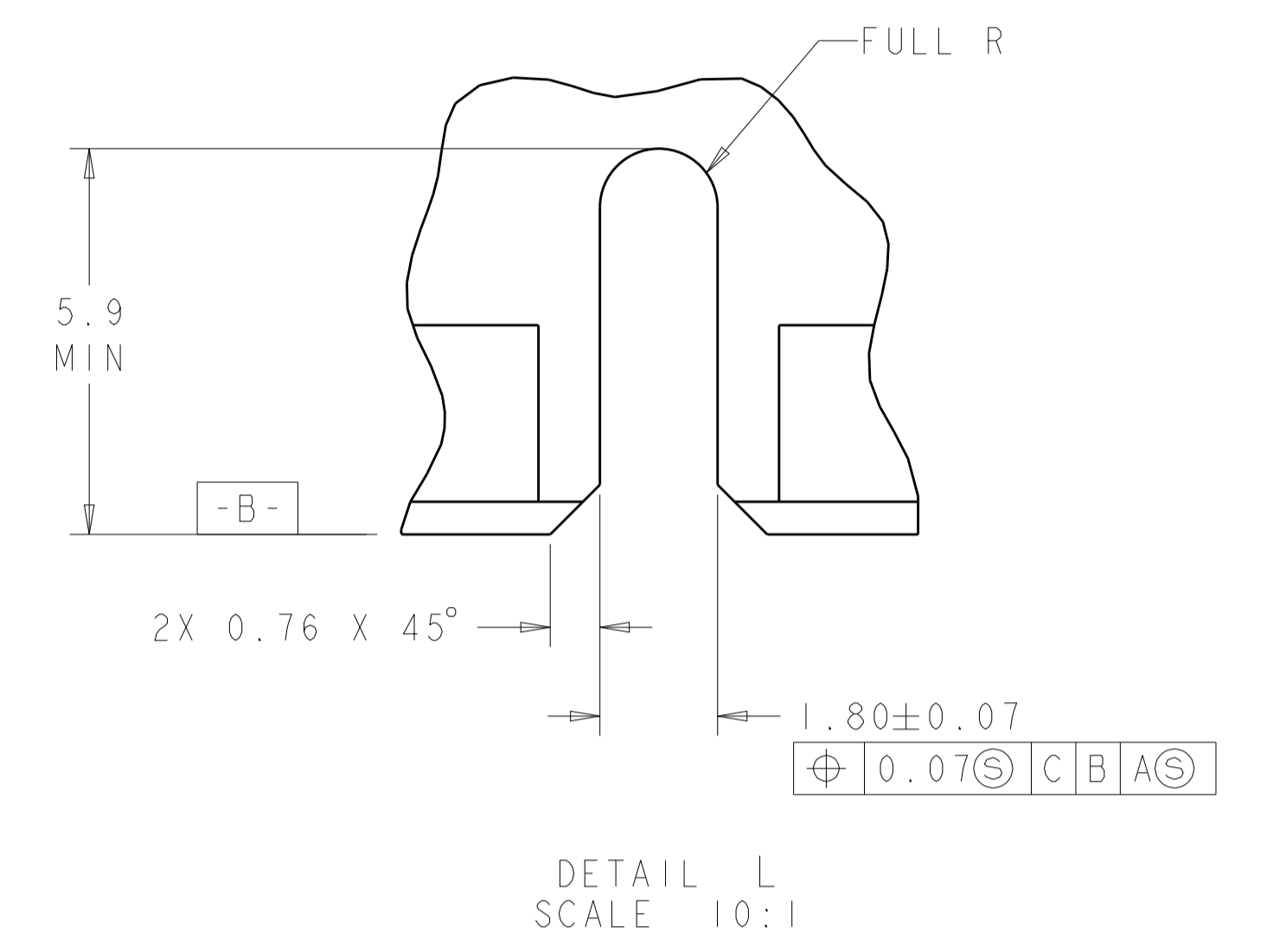
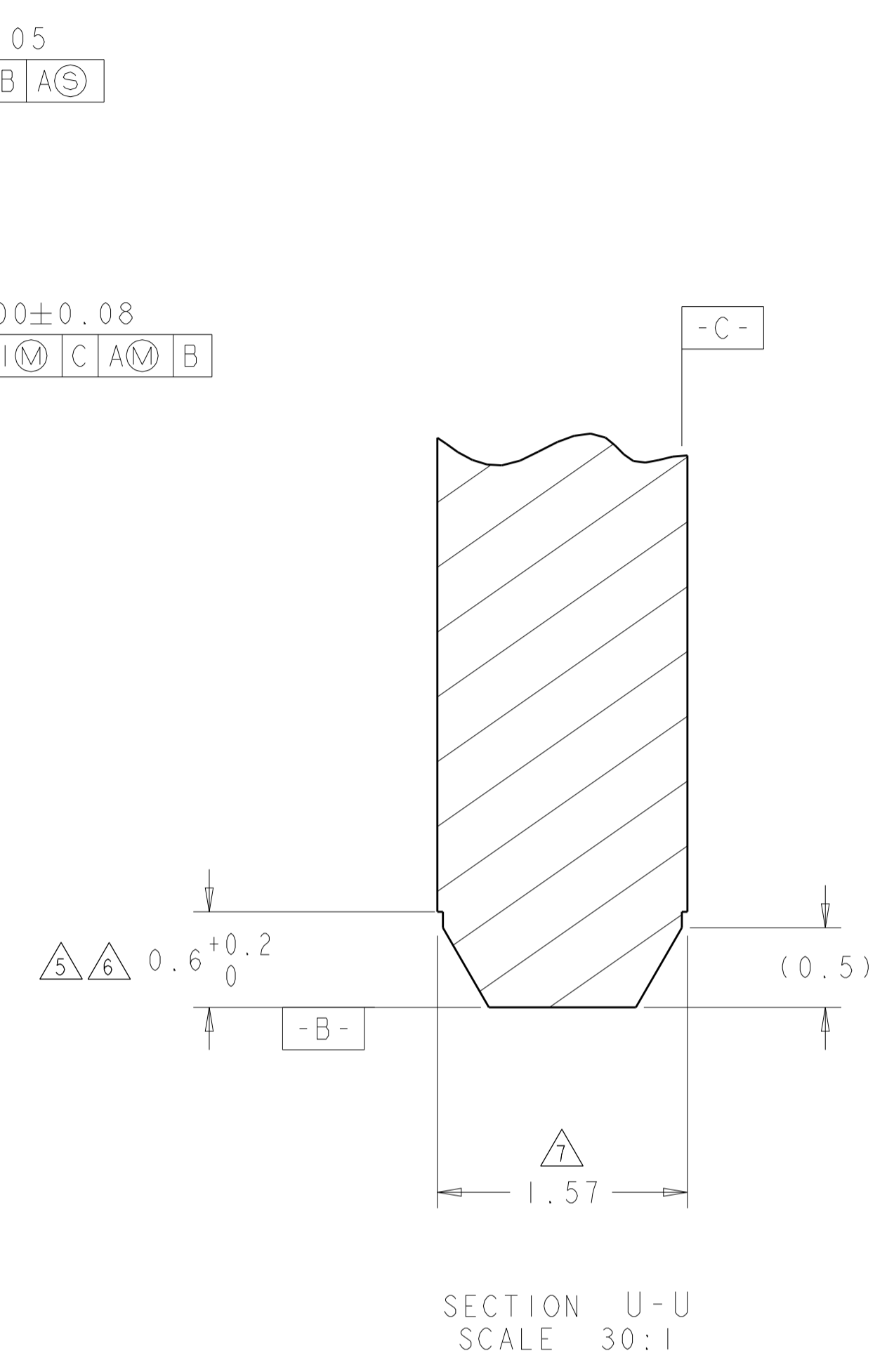

THIS DRAWING IS A CONTROLLED DOCUMENT.		OWN: N. REESER 18JAN2006	TE Connectivity
DIMENSIONS: mm		CHK: P. D'AMATO 29 AUG 07	
TOLERANCES UNLESS OTHERWISE SPECIFIED:		APPV: N. REESER 18JAN2006	NAME: SOCKET CONNECTOR WITH LATCH, SMT P2-S24-P8 MINI CROWN EDGE
0 PLC	±.5	PRODUCT SPEC	SIZE: CAGE CODE: DRAWING NO: RESTRICTED TO
1 PLC	±.25	APPLICATION SPEC	A100779C=1926024
2 PLC	±.2	WEIGHT	SCALE: 1:1 SHEET 3 OF 5 REV: G2
3 PLC	±.1	CUSTOMER DRAWING	
4 PLC	±.05		
ANGLES	±.2		
FINISH			

LOC	DIST	REVISIONS			
P	LTN	DESCRIPTION	DATE	DMN	APVD
GP	00	SEE SHEET 1	-	-	-

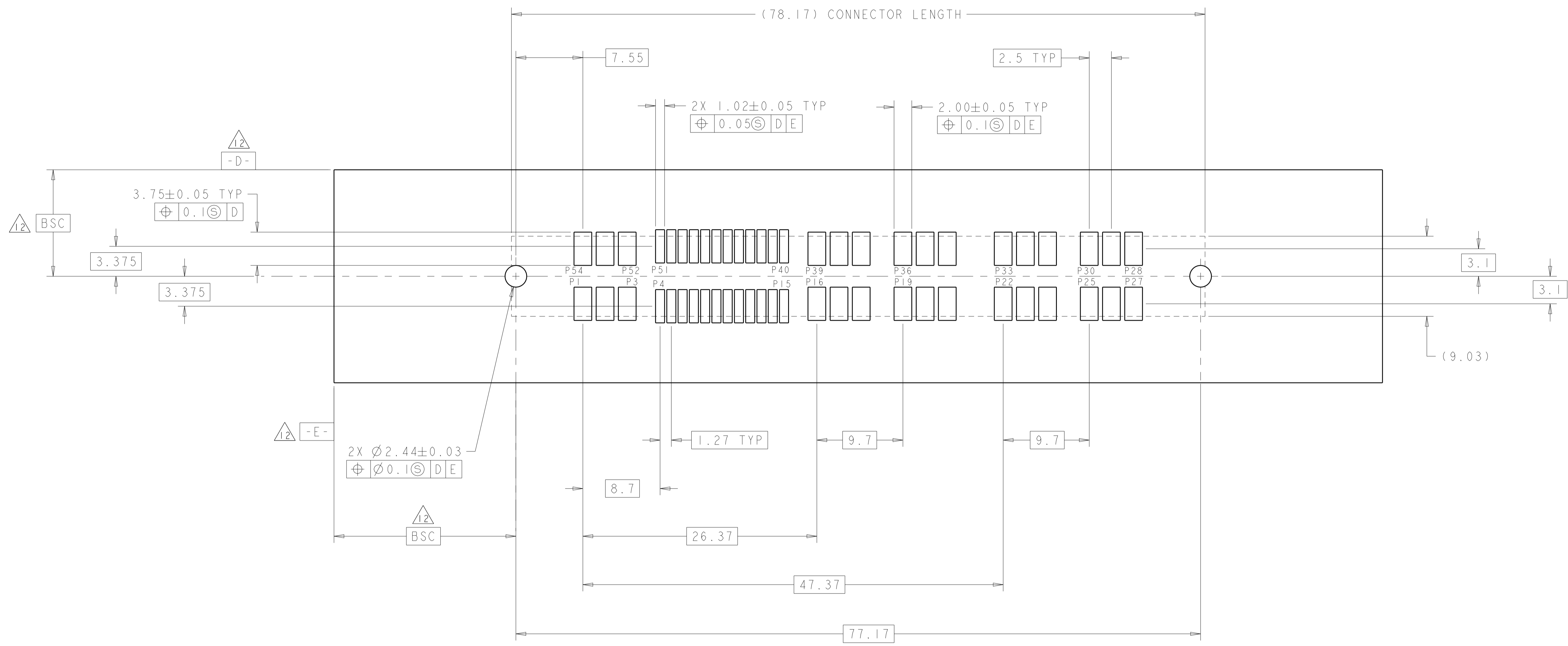

RECOMMENDED SOLDER LAND GUIDELINE
 AS VIEWED FROM CONNECTOR SIDE
 SCALE 4:1

THIS DRAWING IS A CONTROLLED DOCUMENT.		DMN: N. REESER 18JAN2006	TE Connectivity
DIMENSIONS: mm		CHK: P. D'AMATO 29 AUG 07	
		APVD: N. REESER 18JAN2006	NAME: SOCKET CONNECTOR WITH LATCH, SMT P2-S24-P8 MINI CROWN EDGE
TOLERANCES UNLESS OTHERWISE SPECIFIED:		PRODUCT SPEC	SIZE: A100779
0 PLC ±.5		APPLICATION SPEC	CAGE CODE: C=1926024
1 PLC ±.5		WEIGHT	RESTRICTED TO
2 PLC ±.25		CUSTOMER DRAWING	SCALE: 1:1 SHEET 4 OF 5 REV: G2
3 PLC ±.25			
4 PLC ±.25			
ANGLES ±.2			
FINISH			

LOC	DIST	REVISIONS					
		P	LTN	DESCRIPTION	DATE	DWN	APVD
GP	00	-	-	SEE SHEET 1	-	-	-

MODULE EXTRACTION GUIDE

STEP 1

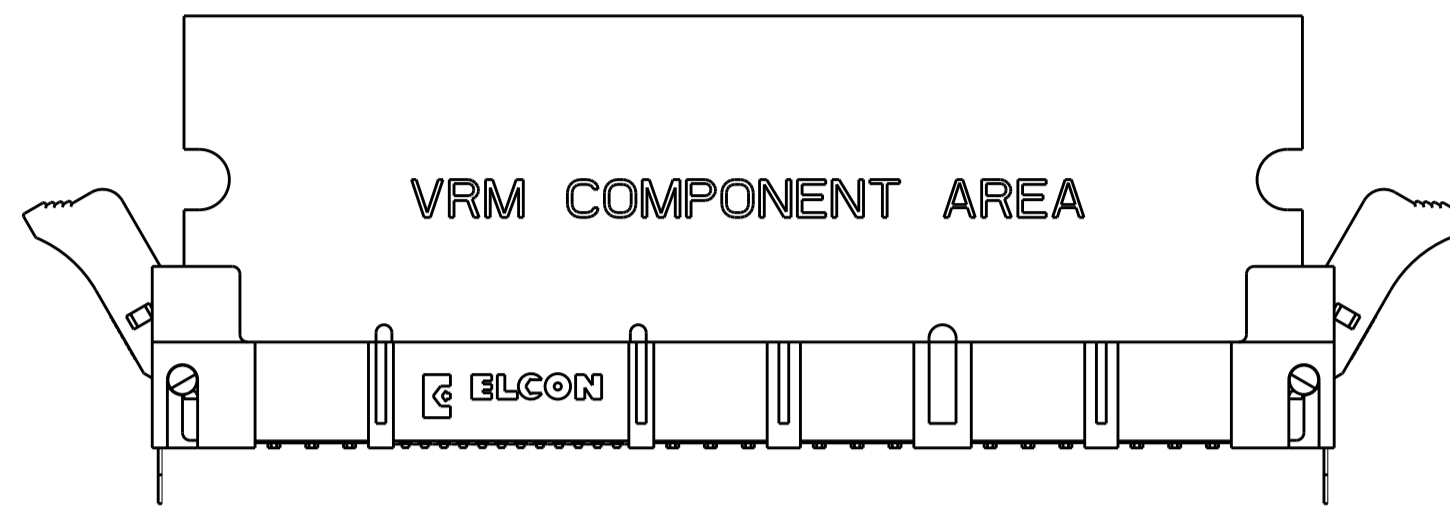

THE MODULE IS REMOVED FROM THE SOCKET FIRST BY SIMULTANEOUSLY ROTATING EACH LATCH APPROXIMATELY 30 DEGREES AWAY FROM THE HOUSING END. AT FULL ROTATION OF THE LATCH, THE MODULE IS NOT COMPLETELY DISLODGED. THE MODULE WILL STILL BE APPROXIMATELY 15% ENGAGED.

STEP 2

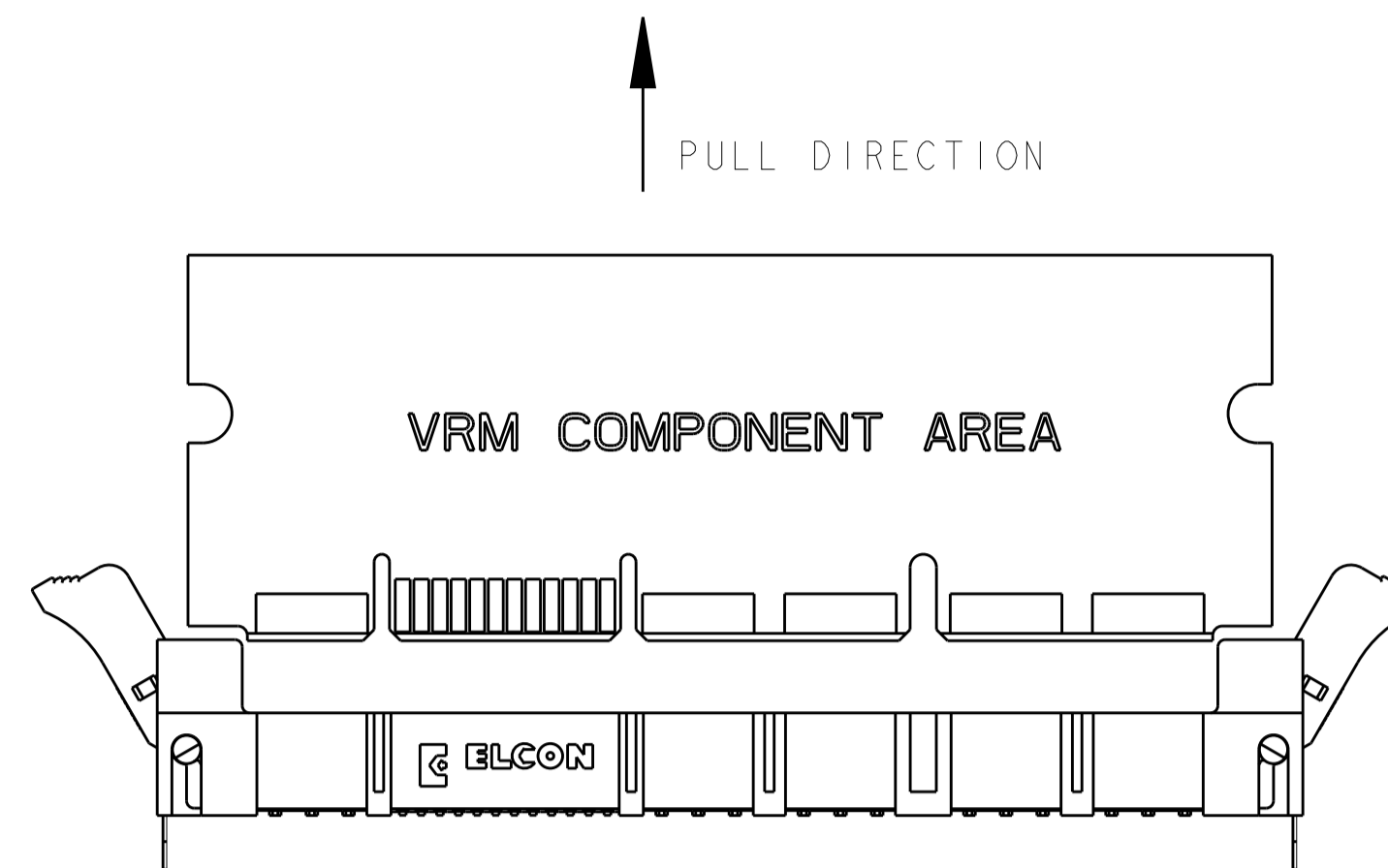

THE COMPLETE REMOVAL OF THE MODULE WILL BE DONE BY PULLING IT STRAIGHT UP THROUGH THE BOARD SUPPORT TOWERS WITH TWO HANDS TO INSURE VERTICAL REMOVAL.

THIS DRAWING IS A CONTROLLED DOCUMENT.		DWN	N. REESER	18JAN2006	 TE Connectivity
		CHK	P. D'AMATO	29 AUG 07	
DIMENSIONS:		TOLERANCES UNLESS OTHERWISE SPECIFIED:		NAME	
mm	0 PLC ±.5 1 PLC ±.5 2 PLC ±.25 3 PLC ±. 4 PLC ±. ANGLES ±.2	APVD	N. REESER	18JAN2006	SOCKET CONNECTOR WITH LATCH, SMT P2-S24-P8 MINI CROWN EDGE
MATERIAL		FINISH		SIZE CAGE CODE DRAWING NO	
-		-		A100779C=1926024	
		CUSTOMER DRAWING		RESTRICTED TO	
				SCALE 1:1 SHEET 5 OF 5 REV G2	

X-ON Electronics

Largest Supplier of Electrical and Electronic Components

Click to view similar products for [Standard Card Edge Connectors](#) category:

Click to view products by [TE Connectivity](#) manufacturer:

Other Similar products are found below :

[6565204-6](#) [PKC-156](#) [1437274-4](#) [147889-1](#) [1489165-4](#) [EBT156-12B1X](#) [EBT15622B2X](#) [EBT156-22R2W](#) [1-582587-1](#) [1-582589-1](#) [2-6437275-9](#) [284-0102-12100](#) [306022901000000](#) [307-012-502-202](#) [307-024-526-201](#) [307-056-520-300](#) [307-080-526-208](#) [1926088-2](#) [245-062-520-350](#) [287-0032-12101](#) [306-010-500-112](#) [306-028-525-102](#) [306-240-318](#) [307-036-502-202](#) [307-036-521-301](#) [307-072-526-202](#) [345-060-559-303](#) [368-004-520-201](#) [392-008-559-201](#) [534671-1](#) [5-530501-5](#) [341-240-317](#) [345-029-520-300](#) [345-030-500-301](#) [345-044-500-300](#) [345-220-058](#) [346-240-318](#) [357-030-526-201](#) [387-012-523-300](#) [395-044-520-300](#) [395-100-524-300](#) [50-12B-10](#) [50-6SN-5](#) [09-07-2032](#) [10035388-106LF](#) [10035388-802LF](#) [10115859-011LF](#) [10122859-009LF](#) [101269333204245CLF](#) [10127905-B04B24BLF](#)