



# STEVAL-IFN004V1

## BLDC six-step motor driver based on the L6230 and STM8S105

### Features

- Input range: 8 V up to 48 V (up to 35 W)
- STMicroelectronics' STM8S105 8-bit microcontroller
- DMOS fully integrated three-phase motor driver L6230 in a QFN package
- Four-layer board
- Best miniaturization vs. thermal performance ratio
- Sensorless and hall-effect sensor operation
- Current sensing mode: single-shunt resistor
- Debug connector
- SPI interface
- RoHS compliant

### Description

The STEVAL-IFN004V1 demonstration board is based on STMicroelectronics' STM8S105 microcontroller and the DMOS fully integrated three-phase motor driver L6230 implementing 6-step scalar control of a BLDC motor.

The board is designed as an evaluation environment for motor control applications in the range of 8 V - 48 V of DC bus voltage and up to 35 W, exploiting the embedded features of the STM8S105. This microcontroller includes internal 2 KB SRAM and 128 KB Flash, and SWD debugging. The L6230 DMOS driver features 2.8 A output peak current, non-dissipative overcurrent detection/protection, cross-conduction protection, internal comparator used for cycle-by-cycle current limitation/regulation, thermal shutdown and undervoltage lockout.

The STEVAL-IFN004V1 is provided with a specific BEMF detection network with dynamic method selection.



Offering dedicated hardware evaluation features, the STEVAL-IFN004V1 board is designed to help developers evaluate the device and develop their own applications. The STEVAL-IFN004V1 can be used together with the STM8Sxxx three-phase BLDC motor control software library and constitutes a cost-effective complete motor control evaluation and development platform.



Figure 2. Schematic (part 2)

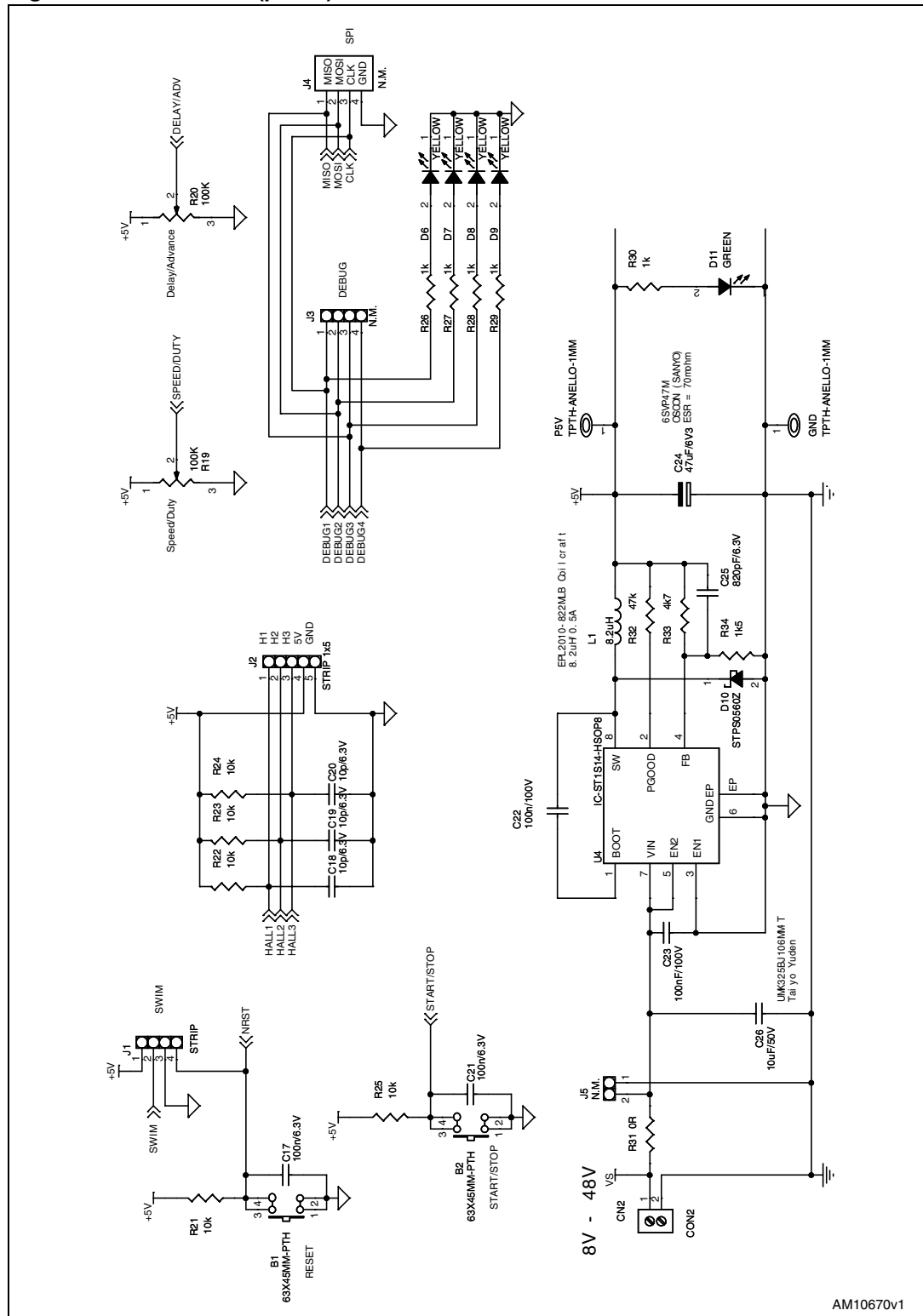

AM10670v1

## 2 Revision history

**Table 1. Document revision history**

Date	Revision	Changes
20-Oct-2011	1	Initial release.

**Please Read Carefully:**

Information in this document is provided solely in connection with ST products. STMicroelectronics NV and its subsidiaries ("ST") reserve the right to make changes, corrections, modifications or improvements, to this document, and the products and services described herein at any time, without notice.

All ST products are sold pursuant to ST's terms and conditions of sale.

Purchasers are solely responsible for the choice, selection and use of the ST products and services described herein, and ST assumes no liability whatsoever relating to the choice, selection or use of the ST products and services described herein.

No license, express or implied, by estoppel or otherwise, to any intellectual property rights is granted under this document. If any part of this document refers to any third party products or services it shall not be deemed a license grant by ST for the use of such third party products or services, or any intellectual property contained therein or considered as a warranty covering the use in any manner whatsoever of such third party products or services or any intellectual property contained therein.

**UNLESS OTHERWISE SET FORTH IN ST'S TERMS AND CONDITIONS OF SALE ST DISCLAIMS ANY EXPRESS OR IMPLIED WARRANTY WITH RESPECT TO THE USE AND/OR SALE OF ST PRODUCTS INCLUDING WITHOUT LIMITATION IMPLIED WARRANTIES OF MERCHANTABILITY, FITNESS FOR A PARTICULAR PURPOSE (AND THEIR EQUIVALENTS UNDER THE LAWS OF ANY JURISDICTION), OR INFRINGEMENT OF ANY PATENT, COPYRIGHT OR OTHER INTELLECTUAL PROPERTY RIGHT.**

**UNLESS EXPRESSLY APPROVED IN WRITING BY TWO AUTHORIZED ST REPRESENTATIVES, ST PRODUCTS ARE NOT RECOMMENDED, AUTHORIZED OR WARRANTED FOR USE IN MILITARY, AIR CRAFT, SPACE, LIFE SAVING, OR LIFE SUSTAINING APPLICATIONS, NOR IN PRODUCTS OR SYSTEMS WHERE FAILURE OR MALFUNCTION MAY RESULT IN PERSONAL INJURY, DEATH, OR SEVERE PROPERTY OR ENVIRONMENTAL DAMAGE. ST PRODUCTS WHICH ARE NOT SPECIFIED AS "AUTOMOTIVE GRADE" MAY ONLY BE USED IN AUTOMOTIVE APPLICATIONS AT USER'S OWN RISK.**

Resale of ST products with provisions different from the statements and/or technical features set forth in this document shall immediately void any warranty granted by ST for the ST product or service described herein and shall not create or extend in any manner whatsoever, any liability of ST.

ST and the ST logo are trademarks or registered trademarks of ST in various countries.

Information in this document supersedes and replaces all information previously supplied.

The ST logo is a registered trademark of STMicroelectronics. All other names are the property of their respective owners.

© 2011 STMicroelectronics - All rights reserved

STMicroelectronics group of companies

Australia - Belgium - Brazil - Canada - China - Czech Republic - Finland - France - Germany - Hong Kong - India - Israel - Italy - Japan - Malaysia - Malta - Morocco - Philippines - Singapore - Spain - Sweden - Switzerland - United Kingdom - United States of America

[www.st.com](http://www.st.com)

## X-ON Electronics

Largest Supplier of Electrical and Electronic Components

*Click to view similar products for [Development Boards & Kits - Other Processors](#) category:*

*Click to view products by [STMicroelectronics](#) manufacturer:*

Other Similar products are found below :

[KIT\\_AURIX\\_TC233LP\\_TRB](#) [EVB-MEC1418MECC](#) [SPC56XVTOP-M](#) [ADZS-BF506F-EZLITE](#) [ADZS-SADA2-BRD](#) [20-101-1252](#)  
[T1023RDB-PC](#) [20-101-1267](#) [T1042D4RDB-PA](#) [ML610Q174](#) [REFERENCE BOARD](#) [MPC574XG-MB](#) [BSC9132QDS](#) [C29XPCIE-RDB](#)  
[KIT\\_TC1793\\_SK](#) [CC-ACC-18M433](#) [P1010RDB-PB](#) [P1020RDB-PD](#) [P2020COME-DS-PB](#) [STM8S/32-D/RAIS](#) [T4240RDB-PB](#) [TRK-USB-](#)  
[MPC5604B](#) [TWR-56F8200](#) [CY3674](#) [SPC58XXADPT176S](#) [MAX1464EVKIT](#) [TRK-MPC5606B](#) [RTE510Y470TGB00000R](#) [STM8128-](#)  
[MCKIT](#) [MAXQ622-KIT#](#) [YRPBRL78G11](#) [SPC58EEMU](#) [QB-R5F10JGC-TB](#) [YQB-R5F11BLE-TB](#) [SPC564A70AVB176](#)  
[RTE5117GC0TGB00000R](#) [QB-R5F100LE-TB](#) [YR0K50571MS000BE](#) [YQB-R5F1057A-TB](#) [QB-R5F104PJ-TB](#) [CC-ACC-ETHMX](#)  
[LFM34INTPQA](#) [SPC563M64A176S](#) [Y-BLDC-SK-RL78F14](#) [P1021RDB-PC](#) [SPC58XCADPT176S](#) [RTE510MPG0TGB00000R](#)  
[YRPBRX71M](#) [LFMAJ04PLT](#) [KITAURIXTC234LPSTRBTOBO1](#) [OV-7604-C7-EVALUATION-BOARD](#)