

Thyristors type T75 are of modern design with pressure contacts, high alumina ceramic insulator and cold-welding encapsulation. Designed for use in power electronic circuits and equipment under normal operating conditions.

KEY PARAMETERS

U_{DRM}, U_{RRM}	up to 2000 V
$I_{T(AV)}$	650 A
I_{TSM}	8100 A
du/dt^*	1000 V/μs
di/dt	150 A/μs

* maximum (non standard) value

FEATURES

- all diffused design
- high current capabilities
- high surge current capabilities
- high rates voltages
- high du/dt
- low gate current
- dynamic gate
- low thermal impedance
- tested according to IEC standards
- compact size and small weight

APPLICATION

- High Power Drives
- DC Motor Control
- High Voltage Power Supplies

Designed for use in high power industrial and commercial electronic circuits and equipment where high currents are encountered and high reliability is essential.

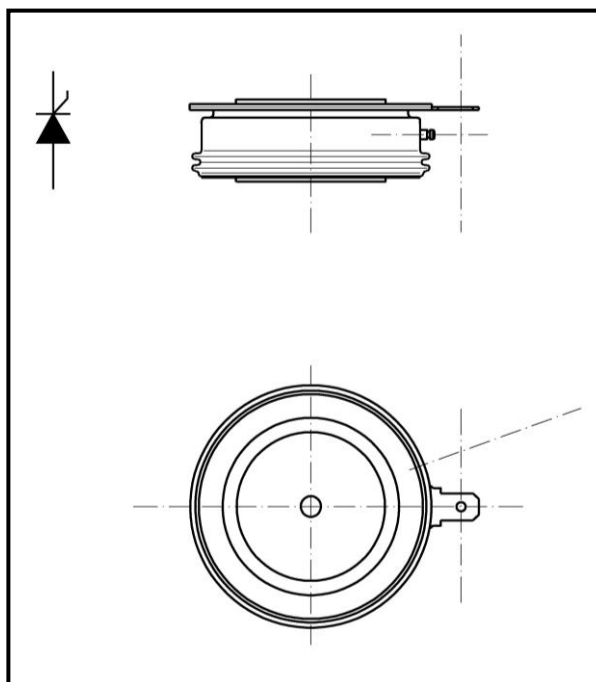

**Outline type code: JEDEC TO-200AB
(E-puk)**

See package details for further information

T75-650

Phase Control Thyristor



Zakłady Elektronowe
LAMINA S.A.

KKT75650, March 2003 version

ORDERING INFORMATION

When ordering please refer to device code builder presented below.
Please use the complete part number when ordering, quote or in any future correspondence relating to your order.

T75-650-□□

└── voltage class (hundreds of volts)

This is standard device, with no dynamic parameters specified and standard accessory set.
Please refer to **Electrical Parameters** if specific dynamic demands have to be met.
Those information, as well as any other concerning non-standard accessories e.g. custom leads length or lead terminal connector type should be included in the order.

ELECTRICAL PARAMETERS

Voltage ratings

Voltage class	U_{DRM}, U_{RRM}	U_{DSM}, U_{RSM}	I_{DRM}, I_{RRM}
	V	V	mA
04	400	500	30
06	600	700	
08	800	900	
10	1000	1100	
12	1200	1300	
14	1400	1500	
16	1600	1700	
18	1800	1900	
20	2000	2100	

du/dt group codes

Group code	du/dt
	V/μs
0	no specified value
5	320
6	500
7	1000

Zakłady Elektronowe LAMINA S.A.
Puławska 34
PL-05-500 Piaseczno
POLAND

Tel.: +48-22-7572731
Tel.: +48-22-3989409
Fax.: +48-22-3989407
e-mail: sekretariat@lamina.com.pl
www.lamina.com.pl

T75-650

Phase Control Thyristor



Zakłady Elektronowe
LAMINA S.A.

KKT75650, March 2003 version

Electrical properties

Parameter	Unit	Test conditions	Value
Average on-state current	$I_{T(AV)}$	A	650
Case temperature	T_c	°C	65
RMS on-state current	$I_{T(RMS)}$	A	1000
Surge on-state current	I_{TSM}	A	$T_j=125^\circ\text{C}$, $U_R=0,8U_{RRM}$, $t_p=10\text{ms}$
I^2t – value	I^2t	kA^2s	330
On-state voltage max.	U_{TM}	V	$T_j=25^\circ\text{C}$, $I_{TM}=1500\text{A}$
Threshold voltage	$U_{T(T0)}$	V	0,93
Slope resistance	r_T	$\text{m}\Omega$	0,71
Latching current	I_l	mA	$T_j=25^\circ\text{C}$, $U_D=12\text{V}$
Holding current	I_H	mA	$T_j=25^\circ\text{C}$, $U_D=12\text{V}$
Circuit commutated turn-off time (typical)	t_q (typ)	μs	$T_j=125^\circ\text{C}$, $I_{TM}=250\text{A}$, $di_R/dt=25\text{A}/\mu\text{s}$, $du/dt=20\text{V}/\mu\text{s}$, $U_D=0,67U_{DRM}$, $U_{RM}=100\text{V}$
Turn-On time (typical)	t_{on}	μs	$I_{TM}=100\text{A}$, $U_{DM}=100\text{V}$
Rate of rise of on-state current-repetitive	di/dt	$\text{A}/\mu\text{s}$	$T_j=125^\circ\text{C}$, $I_{TM}=3I_{T(AV)}$, $U_D=0,67U_{DRM}$, $f=50\text{Hz}$, $I_{GM}=1\text{A}$, $di_G/dt=1\text{A}/\mu\text{s}$
Critical rate of raise of off-state voltage	du/dt	$\text{V}/\mu\text{s}$	$T_j=125^\circ\text{C}$, $U_D=0,67U_{DRM}$
Gate current to trigger	I_{GT}	mA	$T_j=25^\circ\text{C}$, $U_D=12\text{V}$
Gate voltage to trigger	U_{GT}	V	$T_j=25^\circ\text{C}$, $U_D=12\text{V}$

Thermal properties

Parameter	Unit	Test conditions	Value
Thermal resistance, junction to case	R_{thJC}	°C/W	two sided, DC
Thermal resistance, case to heatsink	R_{thCS}	°C/W	two sided
Operating junction temperature	$T_{jmin} \dots T_{jmax}$	°C	-40...+125
Storage temperature	T_{stg}	°C	-40...+125

Mechanical properties

Parameter	Unit	Value
Clamping force	F_M	kN
Weight	m	g

Zakłady Elektronowe LAMINA S.A.
Puławska 34
PL-05-500 Piaseczno
POLAND

Tel.: +48-22-7572731
Tel.: +48-22-3989409
Fax.: +48-22-3989407
e-mail: sekretariat@lamina.com.pl
www.lamina.com.pl

T75-650

Phase Control Thyristor

KKT75650, March 2003 version

Package details

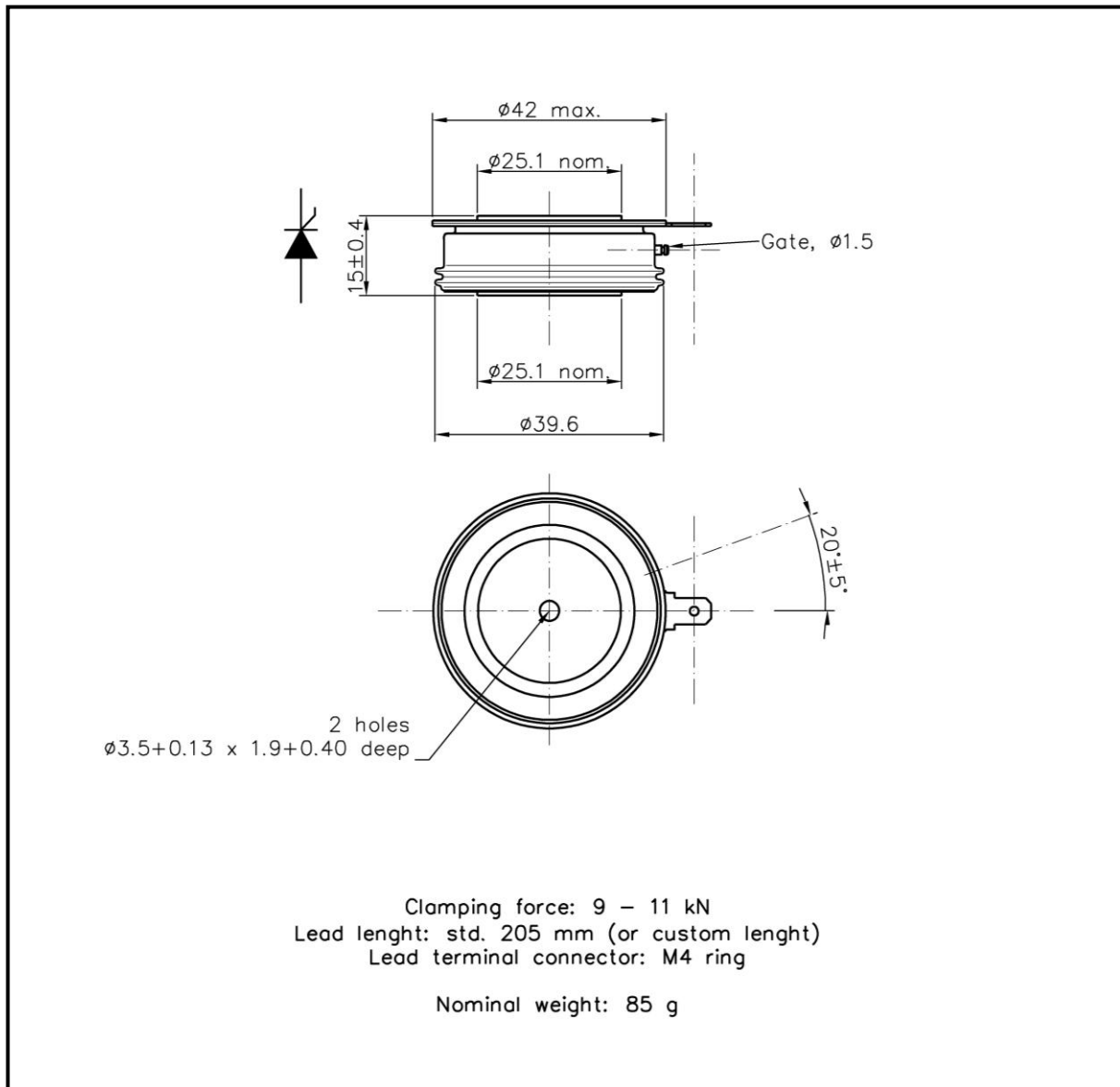

For further package information, please contact Sales & Marketing Department. All dimensions in mm, unless stated otherwise.
Do not scale.

T75-650

Phase Control Thyristor

KKT75650, March 2003 version

CHARACTERISTICS

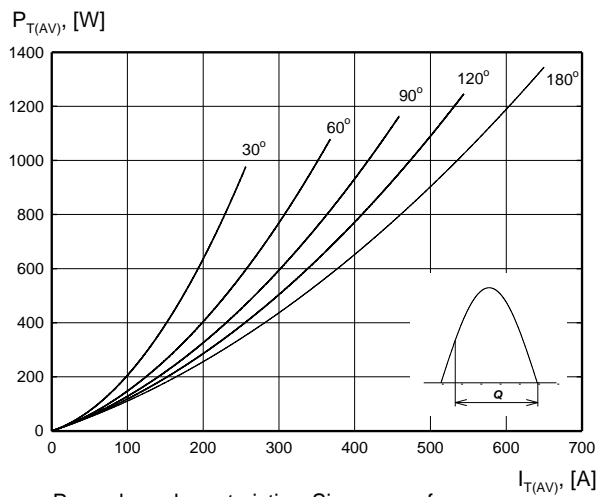

Power loss characteristics. Sinus wave form.

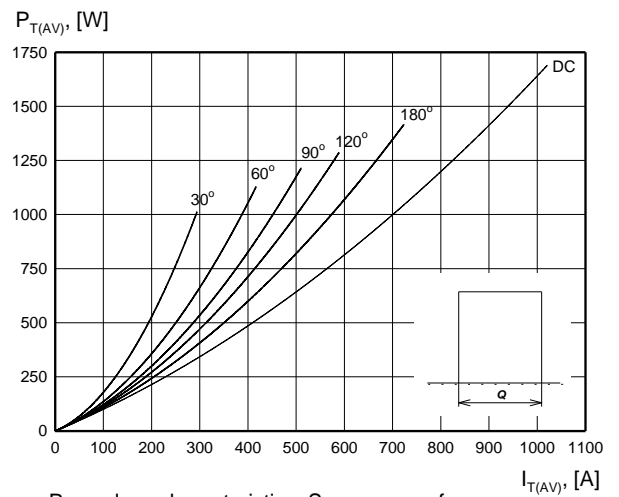

Power loss characteristics. Square wave form.

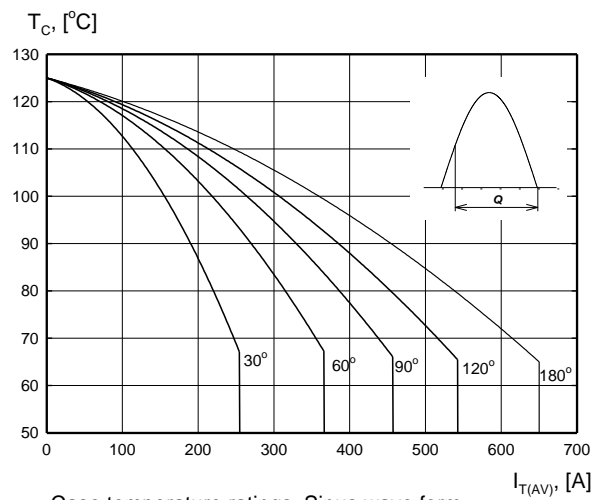

Case temperature ratings. Sinus wave form.

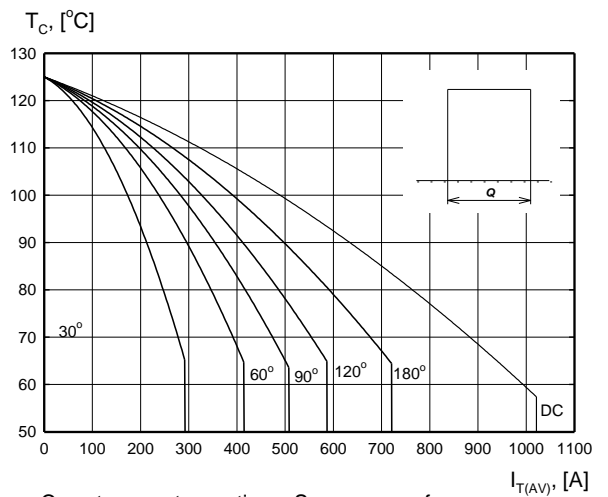

Case temperature ratings. Square wave form.

T75-650

Phase Control Thyristor



Zakłady Elektronowe
LAMINA S.A.

KKT75650, March 2003 version

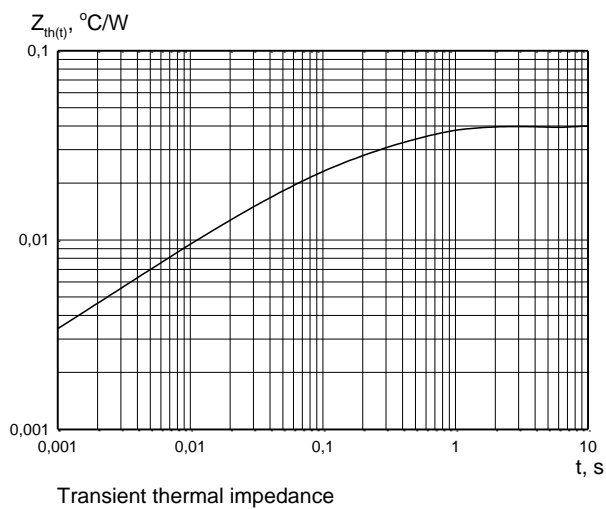
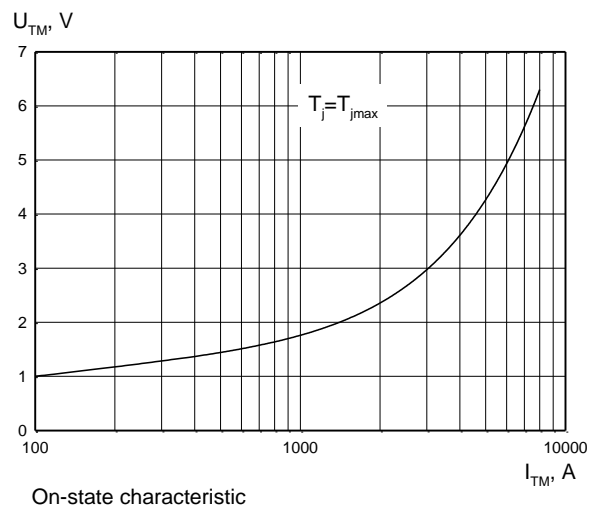
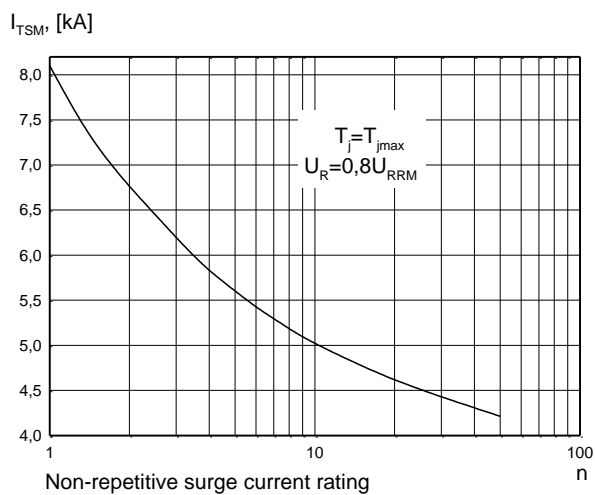

Zakłady Elektronowe LAMINA S.A.
 Puławska 34
 PL-05-500 Piaseczno
 POLAND

Tel.: +48-22-7572731
 Tel.: +48-22-3989409
 Fax.: +48-22-3989407
 e-mail: sekretariat@lamina.com.pl
 www.lamina.com.pl

T75-650

Phase Control Thyristor

KKT75650, March 2003 version

Gate characteristics

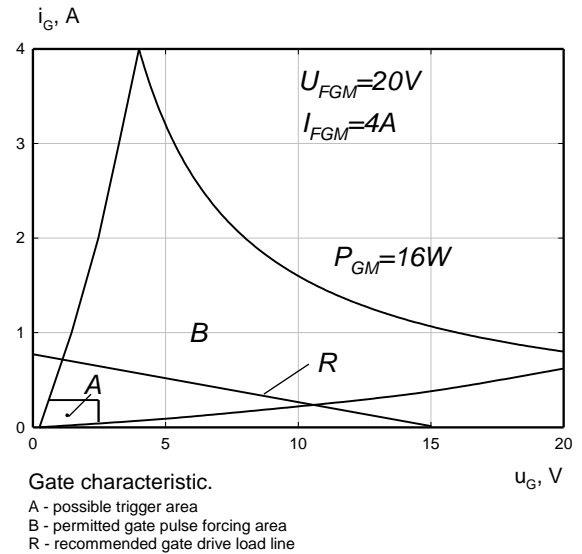
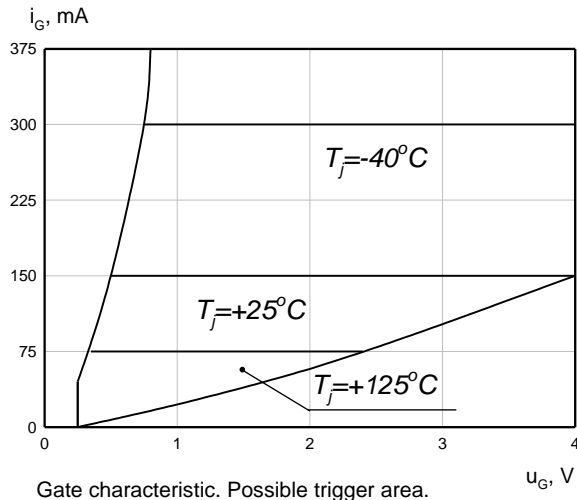

HEATSINKS

LAMINA S.I. has its own proprietary range of extruded aluminium heatsinks designed to optimise the performance of our semiconductors with natural and forced air flow. High efficiency water cooled copper heatsinks are also available.

DEVICE CLAMPS

Disc devices require the correct clamping force to ensure their best operation. LAMINA S.I. offers a wide selection of clamps to suit all of our manufactured devices.

POWER ASSEMBLY CAPABILITY

LAMINA S.I. provides a support for those customers requiring more than a basic semiconductor and offers precisely assembled Power Blocks according to factory or customer standards.

X-ON Electronics

Largest Supplier of Electrical and Electronic Components

Click to view similar products for [SCRs](#) category:

Click to view products by [Lamina](#) manufacturer:

Other Similar products are found below :

[NTE5428](#) [NTE5448](#) [NTE5457](#) [NTE5511](#) [T1500N16TOF VT](#) [T720N18TOF](#) [T880N14TOF](#) [T880N16TOF](#) [TS110-7UF](#) [TT104N12KOF-A](#)
[TT104N12KOF-K](#) [TT162N16KOF-A](#) [TT162N16KOF-K](#) [TT330N16AOF](#) [VS-16RIA100](#) [VS-22RIA20](#) [VS-2N5206](#) [VS-2N685](#) [VS-](#)
[40TPS08A-M3](#) [VS-ST230S12P1VPBF](#) [057219R](#) [CLB30I1200HB](#) [T1190N16TOF VT](#) [T1220N22TOF VT](#) [T201N70TOH](#) [T830N18TOF](#)
[TD92N16KOF-A](#) [TT250N12KOF-K](#) [VS-2N692](#) [VS-2N689](#) [VS-25RIA40](#) [VS-16RIA120](#) [VS-10RIA120](#) [VS-30TPS08PBF](#) [NTE5427](#)
[NTE5442](#) [VS-2N690](#) [VS-ST300S20P0PBF](#) [TT251N16KOF-K](#) [VS-22RIA100](#) [VS-16RIA40](#) [CR02AM-8#F00](#) [VS-ST110S12P0VPBF](#)
[TD250N16KOF-A](#) [VS-ST110S16P0](#) [VS-10RIA10](#) [VS-16TTS08-M3](#) [TS110-7A1-AP](#) [T930N36TOF VT](#) [T2160N24TOF VT](#)