

Overview

KEMET's PEH536 is a long-life electrolytic capacitor designed to offer high ripple current capability and low mounting cost. Low ESR is the result of a very low resistive paper/electrolyte system. Low ESR, together with the TDC thermal concept, gives the PEH536 a high ripple current capability.

Applications

Typical applications for KEMET's PEH536 capacitor include switch mode power supplies (SMPS), drives, welding equipment, uninterruptible power supplies (UPS), and other power electronic applications where high current ratings and compact size are important.

Benefits

- Snap-In
- 4,600 hours at +105°C (V_R , I_R applied)
- PCB mounting
- Low ESR and ESL
- High ripple current



Part Number System

PEH536	J	AD	439	0	M	2
Series	Voltage (VDC)	Size Code	Capacitance Code (μF)	Version	Capacitance Tolerance	Termination
Snap-In type Aluminum Electrolytic	J = 35 M = 63 P = 100 R = 200 S = 250 U = 350 V = 400 Y = 450	See Dimension Table	The second two digits indicate the two most significant digits of the capacitance value. The first digit indicates the total number digits.	0 = Standard	M = $\pm 20\%$	See Termination Table

Performance Characteristics

Item	Performance Characteristics		
Capacitance Range	47 – 18,000 μ F		
Rated Voltage	35 – 450 VDC		
Operating Temperature	-40 to +105°C		
Capacitance Tolerance	\pm 20% at 100 Hz / +20°C		
Operational Lifetime	D (mm)	Rated Voltage and Ripple Current at +105°C (hours)	Rated Voltage at +105°C (hours)
	22 – 40	4,600	6,000
Shelf Life	4 years at +40°C 0 VDC		
Leakage Current	I = 0.003 CV (μ A)		
	C = rated capacitance (μ F), V = rated voltage (VDC). Voltage applied for 5 minutes at +20°C.		
Vibration Test Specifications	Procedure	Requirements	
	0.75 mm displacement amplitude or 10 g maximum acceleration. Vibration applied for three 2-hour sessions at 10 – 500 Hz (Capacitor clamped by body).	No leakage of electrolyte or other visible damage. Deviations in capacitance and $\tan\delta$ from initial measurements must not exceed: $\Delta C/C < 5\%$	
Standards	IEC 60384-4 long life grade 40/85/56, in accordance with CECC 30 301–809		

Test Method & Performance

Endurance Life Test		
Conditions	Performance	
Temperature	+105°C	
Test Duration	2,000 hours	
Ripple Current	Maximum ripple current specified in table	
Voltage	The sum of DC voltage and the peak AC voltage must not exceed the rated voltage of the capacitor	
Performance	The following specifications will be satisfied when the capacitor is tested at +20°C:	
Capacitance Change	≤ 160 V	Within 15% of the initial value
	> 160 V	Within 10% of the initial value
Equivalent Series Resistance	Does not exceed 200% of the initial value	
Leakage Current	Does not exceed leakage current limit	

Dimensions – Millimeters

D X L	Size Code	Dimensions in mm		Approximate Weight Grams
		D1	L1	
		±0.5	±1.0	
22 x 30	AC	22.5	31	14
22 x 35	AD	22.5	36	15
22 x 40	AE	22.5	41	17
22 x 45	AF	22.5	46	19
22 x 50	AG	22.5	51	21
25 x 25	BB	25.5	26	19
25 x 30	BC	25.5	31	21
25 x 35	BD	25.5	36	24
25 x 40	BE	25.5	41	27
25 x 45	BF	25.5	46	30
25 x 50	BG	25.5	51	33
30 x 25	CB	30.5	26	24
30 x 30	CC	30.5	31	29
30 x 35	CD	30.5	36	34
30 x 40	CE	30.5	41	39
30 x 45	CF	30.5	46	45
30 x 50	CG	30.5	51	51
35 x 25	DB	35.5	26	32
35 x 30	DC	35.5	31	40
35 x 35	DD	35.5	36	48
35 x 40	DE	35.5	41	56
35 x 45	DF	35.5	46	64
35 x 50	DG	35.5	51	72
35 x 55	DH	35.5	56	85
35 x 60	DI	35.5	61	88
40 x 60	EI	40.5	61	115
40 x 70	EK	40.5	71	135
40 x 80	EM	40.5	81	155
40 x 100	EQ	40.5	101	175

Note: Add 0.5 mm to D and 1 mm to L for Slewing

Termination Tables

Termination Code	2	2S	3	4	4S
Diameter (mm)					
22	•	•	•		
25	•	•	•		
30	•	•	•		
35	•	•	•	•	•
40	•	•	•	•	•

Mounting: These capacitors are designed to be mounted by their terminations alone and may be used in any position.
 Dummy pins on 4-pin decks must be isolated.

Termination Code	Termination Style	LL
		±1
Standard Termination Option		
2	2 Pin	6.3
4 (D = 40)	4 Pin	6.3
Other Termination Options		
2S	2 Pin	4
3	3 Pin	4
4S	4 Pin	4

Dimensions in mm

Style 2/2S

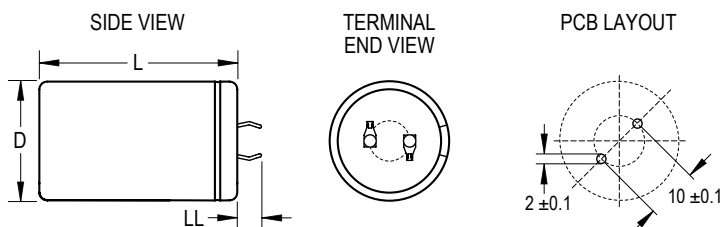

Style 3

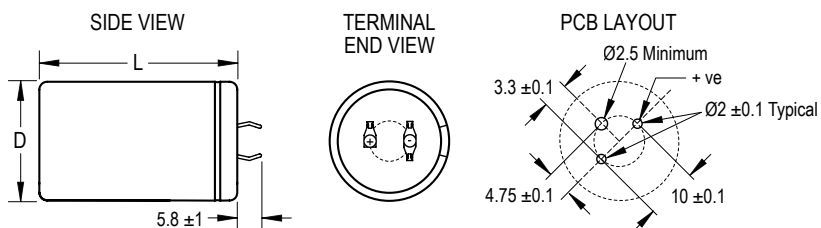

Style 4/4S

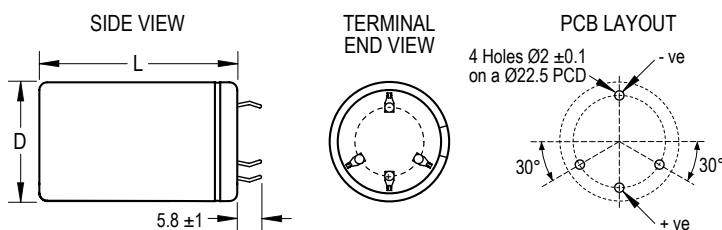

Shelf Life

The capacitance, ESR and impedance of a capacitor will not change significantly after extended storage periods, however the leakage current will very slowly increase. KEMET products are particularly stable and allow a shelf life in excess of three years at 40°C. See sectional specification under each product series for specific data.

Re-age (Reforming) Procedure

Apply the rated voltage to the capacitor at room temperature for a period of one hour, or until the leakage current has fallen to a steady value below the specified limit. During re-aging a maximum charging current of twice the specified leakage current or 5 mA (whichever is greater) is suggested.

Reliability

The reliability of a component can be defined as the probability that it will perform satisfactorily under a given set of conditions for a given length of time.

In practice, it is impossible to predict with absolute certainty how any individual component will perform; thus, we must utilize probability theory. It is also necessary to clearly define the level of stress involved (e.g. operating voltage, ripple current, temperature and time). Finally, the meaning of satisfactory performance must be defined by specifying a set of conditions which determine the end of life of the component.

Reliability as a function of time, $R(t)$, is normally expressed as: $R(t)=e^{-\lambda t}$
where $R(t)$ is the probability that the component will perform satisfactorily for time t , and λ is the failure rate.

Failure Rate

The failure rate is the number of components failing per unit time. The failure rate of most electronic components follows the characteristic pattern:

- Early failures are removed during the manufacturing process.
- The operational life is characterized by a constant failure rate.
- The wear out period is characterized by a rapidly increasing failure rate.

The failures in time (FIT) are given with a 60% confidence level for the various type codes. By convention, FIT is expressed as 1×10^{-9} failures per hour. Failure rate is also expressed as a percentage of failures per 1,000 hours.

e.g., 100 FIT = 1×10^{-7} failures per hour = 0.01%/1,000 hours

End of Life Definition

Catastrophic Failure: short circuit, open circuit or safety vent operation

Parametric Failure:

- Change in capacitance $> \pm 10\%$
- Leakage current $>$ specified limit
- ESR $> 2 \times$ initial ESR value

MTBF

The mean time between failures (MTBF) is simply the inverse of the failure rate.

$$\text{MTBF} = 1/\lambda$$

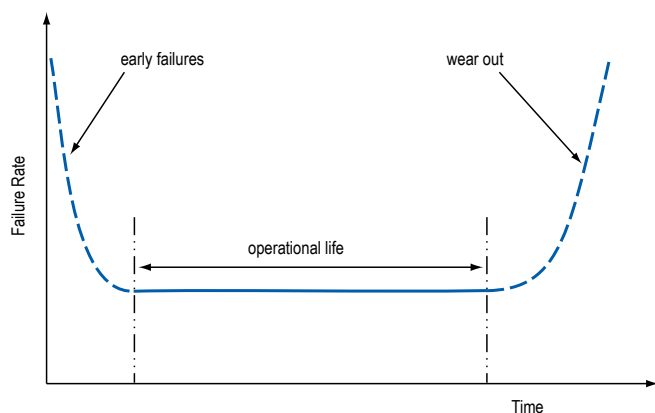

The failure rate is derived from our periodic test results. The failure rate (λ_r) is, therefore, only given at test temperature for life tests. An estimation is also given at 40°C. The expected failure rate for this capacitor range is based on our periodic test results for capacitors with structural similarity. Failure rate is frequently quoted in FIT (Failures In Time) where 1 FIT = 1×10^{-9} failures per hour. Failure rate per hour includes both catastrophic and parametric failures.

Environmental Compliance

As an environmentally conscious company, KEMET is working continuously with improvements concerning the environmental effects of both our capacitors and their production. In Europe (RoHS Directive) and in some other geographical areas like China, legislation has been put in place to prevent the use of some hazardous materials, such as lead (Pb), in electronic equipment. All products in this catalog are produced to help our customers' obligations to guarantee their products and fulfill these legislative requirements. The only material of concern in our products has been lead (Pb), which has been removed from all designs to fulfill the requirement of containing less than 0.1% of lead in any homogeneous material. KEMET will closely follow any changes in legislation world wide and makes any necessary changes in its products, whenever needed.

Some customer segments such as medical, military and automotive electronics may still require the use of lead in electrode coatings. To clarify the situation and distinguish products from each other, a special symbol is used on the packaging labels for RoHS compatible capacitors.

Because of customer requirements, there may appear additional markings such as LF = Lead Free or LFW = Lead Free Wires on the label.

Table 1 – Ratings & Part Number Reference

VDC	Rated Capacitance	Size Code	Case Size	Ripple Current Maximum		ESR Maximum		Part Number
	100 Hz 20°C (µF)		D x L (mm)	100 Hz 105°C (A)	20 kHz 40°C (A)	100 Hz 20°C (mΩ)	100 kHz 20°C (mΩ)	
35	3900	AD	22 x 35	2.4	9.0	54	39	PEH536JAD4390M(1)
35	3900	BC	25 x 30	2.2	7.8	60	45	PEH536JBC4390M(1)
35	4700	AE	22 x 40	2.8	0.2	45	33	PEH536JAE4470M(1)
35	5600	BD	25 x 35	2.7	9.1	44	34	PEH536JBD4560M(1)
35	5600	CC	30 x 30	2.4	7.8	53	43	PEH536JCC4560M(1)
35	5600	DB	35 x 25	2.0	5.9	78	68	PEH536JDB4560M(1)
35	6800	BE	25 x 40	3.1	10.4	37	28	PEH536JBE4680M(1)
35	6800	CD	30 x 35	2.9	9.4	42	33	PEH536JCD4680M(1)
35	8200	BF	25 x 45	3.4	11.6	31	24	PEH536JBF4820M(1)
35	8200	CD	30 x 35	2.8	8.9	42	35	PEH536JCD4820M(1)
35	8200	DC	35 x 30	3.7	12.6	30	23	PEH536JDC4820M(1)
35	10000	BG	25 x 50	3.7	12.3	27	21	PEH536JBG5100M(1)
35	10000	CE	30 x 40	4.6	16.6	22	16	PEH536JCE5100M(1)
35	12000	CF	30 x 45	5.1	18.1	19	14	PEH536JCF5120M(1)
35	12000	DD	35 x 35	4.4	14.5	22	17	PEH536JDD5120M(1)
35	15000	DE	35 x 40	5.0	16.5	18	14	PEH536JDE5150M(1)
35	18000	DG	35 x 50	6.1	20.4	14	11	PEH536JDG5180M(1)
63	1800	AD	22 x 35	1.9	7.3	100	74	PEH536MAD4180M(1)
63	1800	BC	25 x 30	2.0	8.2	97	68	PEH536MBC4180M(1)
63	1800	CB	30 x 25	2.0	7.8	100	72	PEH536MCB4180M(1)
63	2200	BD	25 x 35	2.1	7.8	88	65	PEH536MBD4220M(1)
63	2200	CC	30 x 30	2.3	9.4	81	57	PEH536MCC4220M(1)
63	2200	DB	35 x 25	2.3	8.6	86	62	PEH536MDB4220M(1)
63	2700	AG	22 x 50	2.5	9.8	68	49	PEH536MAG4270M(1)
63	2700	BE	25 x 40	2.4	8.9	73	53	PEH536MBE4270M(1)
63	2700	CD	30 x 35	2.7	10.9	66	46	PEH536MCD4270M(1)
63	3300	BG	25 x 50	2.8	10.7	58	43	PEH536MBG4330M(1)
63	3300	CD	30 x 35	2.9	11.5	55	40	PEH536MCD4330M(1)
63	3900	CE	30 x 40	3.3	13.0	47	34	PEH536MCE4390M(1)
63	3900	DC	35 x 30	3.0	10.9	52	38	PEH536MDC4390M(1)
63	4700	CF	30 x 45	3.7	14.6	39	28	PEH536MCF4470M(1)
63	4700	DD	35 x 35	3.5	12.9	42	31	PEH536MDD4470M(1)
63	6800	DF	35 x 45	4.5	16.4	30	22	PEH536MDF4680M(1)
63	8200	DG	35 x 50	5.0	17.9	25	19	PEH536MDG4820M(1)
100	560	AC	22 x 30	1.1	4.3	320	240	PEH536PAC3560M(1)
100	560	BB	25 x 25	1.1	4.0	330	250	PEH536PBB3560M(1)
100	680	AD	22 x 35	1.2	5.0	260	190	PEH536PAD3680M(1)
100	680	BC	25 x 30	1.2	4.8	270	200	PEH536PBC3680M(1)
100	820	AE	22 x 40	1.4	5.6	220	160	PEH536PAE3820M(1)
100	820	BC	25 x 30	1.3	5.1	230	170	PEH536PBC3820M(1)
100	820	CB	30 x 25	1.4	5.6	220	160	PEH536PCB3820M(1)
100	1000	BD	25 x 35	1.6	6.0	180	140	PEH536PBD4100M(1)
100	1000	CC	30 x 30	1.7	6.6	180	130	PEH536PCC4100M(1)
100	1200	BE	25 x 40	1.8	6.8	150	120	PEH536PBE4120M(1)
100	1200	CD	30 x 35	1.9	7.7	150	110	PEH536PCD4120M(1)
100	1500	BG	25 x 50	2.1	8.1	120	92	PEH536PBG4150M(1)
100	1500	CE	30 x 40	2.2	8.9	120	88	PEH536PCE4150M(1)
100	2200	CG	30 x 50	2.8	11.2	81	61	PEH536PCG4220M(1)
100	2200	DE	35 x 40	2.8	10.9	83	62	PEH536PDE4220M(1)
100	2700	DF	35 x 45	3.2	12.3	68	51	PEH536PDF4270M(1)
100	3300	DG	35 x 50	3.6	13.8	56	43	PEH536PDG4330M(1)
100	4700	DH	35 x 55	4.3	15.8	42	32	PEH536PDH4470M(1)
200	220	AC	22 x 30	0.7	5.4	550	270	PEH536RAC3220M(1)
200	270	BC	25 x 30	0.8	5.9	460	220	PEH536RBC3270M(1)
200	330	AE	22 x 40	0.9	7.2	370	180	PEH536RAE3330M(1)
200	330	BD	25 x 35	1.0	6.9	370	190	PEH536RBD3330M(1)
200	470	AG	22 x 50	1.2	8.8	260	130	PEH536RAG3470M(1)
200	470	BE	25 x 40	1.2	8.1	270	130	PEH536RBE3470M(1)
200	560	BF	25 x 45	1.3	9.1	220	110	PEH536RBF3560M(1)
VDC	Rated Capacitance	Size Code	Case Size	Ripple Current		ESR		Part Number

(1) Termination code: See Termination Tables for available options.

Table 1 – Ratings & Part Number Reference cont'd

VDC	Rated Capacitance	Size Code	Case Size	Ripple Current Maximum		ESR Maximum		Part Number
	100 Hz 20°C (µF)		D x L (mm)	100 Hz 105°C (A)	20 kHz 40°C (A)	100 Hz 20°C (mΩ)	100 kHz 20°C (mΩ)	
200	560	CD	30 x 35	1.4	10.4	220	110	PEH536RCD3560M(1)
200	680	BG	25 x 50	1.5	10.0	180	93	PEH536RBG3680M(1)
200	680	CE	30 x 40	1.6	11.8	180	88	PEH536RCE3680M(1)
200	680	DD	35 x 35	1.6	11.5	180	90	PEH536RDD3680M(1)
200	820	CF	30 x 45	1.8	13.3	150	73	PEH536RCF3820M(1)
200	820	DD	35 x 35	1.8	11.8	150	77	PEH536RDD3820M(1)
200	1000	CG	30 x 50	2.0	14.8	120	61	PEH536RCG4100M(1)
200	1000	DE	35 x 40	2.0	13.5	130	63	PEH536RDE4100M(1)
200	1200	DG	35 x 50	2.3	16.2	100	52	PEH536RDG4120M(1)
250	150	AC	22 x 30	0.6	5.3	660	280	PEH536SAC3150M(1)
250	220	AE	22 x 40	0.8	7.0	450	190	PEH536SAE3220M(1)
250	220	BC	25 x 30	0.8	6.0	460	200	PEH536SBC3220M(1)
250	270	BD	25 x 35	0.9	7.1	370	160	PEH536SBD3270M(1)
250	330	BE	25 x 40	1.0	8.1	300	130	PEH536SBE3320M(1)
250	330	CC	30 x 30	1.1	8.8	300	130	PEH536SCC3330M(1)
250	390	BF	25 x 45	1.2	9.0	260	110	PEH536SBF3390M(1)
250	470	BG	25 x 50	1.3	9.9	210	96	PEH536SBG3470M(1)
250	470	CE	30 x 40	1.4	11.7	210	91	PEH536SCE3470M(1)
250	560	CF	30 x 45	1.6	13.1	180	76	PEH536SCF3560M(1)
250	680	CG	30 x 50	1.8	14.5	150	63	PEH536SCG3680M(1)
250	680	DE	35 x 40	1.8	13.4	150	66	PEH536SDE3680M(1)
250	820	DF	35 x 45	2.0	15.0	120	55	PEH536SDF3820M(1)
250	1000	DG	35 x 50	2.3	16.5	100	46	PEH536SDG4100M(1)
350	100	AC	22 x 30	0.6	3.9	1000	600	PEH536UAC3100M(1)
350	100	BB	25 x 25	0.6	3.7	1100	620	PEH536UBB3100M(1)
350	120	AD	22 x 35	0.6	4.5	870	500	PEH536UAD3120M(1)
350	150	AE	22 x 40	0.7	5.2	700	400	PEH536UAE3150M(1)
350	150	BC	25 x 30	0.7	4.7	710	410	PEH536UBC3150M(1)
350	180	AF	22 x 45	0.8	5.8	580	340	PEH536UAF3180M(1)
350	220	AG	22 x 50	1.0	6.5	480	280	PEH536UAG3220M(1)
350	220	BE	25 x 40	1.0	6.2	480	280	PEH536UBE3220M(1)
350	270	BG	25 x 50	1.1	7.4	390	230	PEH536UBG3270M(1)
350	270	CE	30 x 40	1.2	8.1	390	220	PEH536UCE3270M(1)
350	330	CF	30 x 45	1.3	9.2	320	180	PEH536UCF3330M(1)
350	330	DD	35 x 35	1.3	8.7	320	190	PEH536UDD3330M(1)
350	470	DE	35 x 40	1.6	10.5	230	130	PEH536UDE3470M(1)
350	560	DF	35 x 45	1.8	11.8	190	110	PEH536UDF3560M(1)
350	560	DG	35 x 50	1.9	12.4	190	110	PEH536UDG3560M(1)
350	680	DI	35 x 60	2.2	14.3	160	91	PEH536UDI3680M(1)
350	1000	EM	40 x 80	2.9	18.5	110	63	PEH536UEM4100M(1)
400	68	AC	22 x 30	0.5	3.6	1300	710	PEH536VAC2680M(1)
400	68	BB	25 x 25	0.5	3.5	1300	720	PEH536VBB2680M(1)
400	82	AD	22 x 35	0.6	4.2	1100	590	PEH536VAD2820M(1)
400	100	AD	22 x 35	0.6	4.6	870	480	PEH536VAD3100M(1)
400	100	BC	25 x 30	0.6	4.4	880	490	PEH536VBC3100M(1)
400	120	AE	22 x 40	0.7	5.2	720	400	PEH536VAE3120M(1)
400	150	AG	22 x 50	0.8	6.1	580	320	PEH536VAG3150M(1)
400	150	BE	25 x 40	0.8	5.9	580	330	PEH536VBE3150M(1)
400	150	CC	30 x 30	0.9	6.2	580	320	PEH536VCC3150M(1)
400	180	CD	30 x 35	1.0	7.1	480	270	PEH536VCD3180M(1)
400	180	DC	35 x 30	1.0	7.1	480	270	PEH536VDC3180M(1)
400	220	BG	25 x 50	1.1	7.4	400	220	PEH536VBG3220M(1)
400	220	CE	30 x 40	1.1	8.2	390	220	PEH536VCE3220M(1)
400	270	CF	30 x 45	1.3	9.3	320	180	PEH536VCF3270M(1)
400	330	CG	30 x 50	1.5	10.5	260	150	PEH536VCG3330M(1)
400	330	DE	35 x 40	1.5	10.1	270	150	PEH536VDE3330M(1)
400	390	DF	35 x 45	1.7	11.3	230	130	PEH536VDF3390M(1)
400	470	DG	35 x 50	1.9	12.6	190	110	PEH536VDG3470M(1)
400	560	DH	35 x 55	2.1	13.9	160	89	PEH536VDH3560M(1)
VDC	Rated Capacitance	Size Code	Case Size	Ripple Current		ESR		Part Number

(1) Termination code: See Termination Tables for available options.

Table 1 – Ratings & Part Number Reference cont'd

VDC	Rated Capacitance	Size Code	Case Size	Ripple Current Maximum		ESR Maximum		Part Number
	100 Hz 20°C (µF)		D x L (mm)	100 Hz 105°C (A)	20 kHz 40°C (A)	100 Hz 20°C (mΩ)	100 kHz 20°C (mΩ)	
400	680	EI	40 x 60	2.5	15.9	130	74	PEH536VEI3680M(1)
400	1000	EM	40 x 80	3.1	19.7	90	51	PEH536VEM4100M(1)
400	1500	EQ	40 x 100	3.9	22.9	61	35	PEH536VEQ4150M(1)
450	47	AC	22 x 30	0.4	3.4	1500	840	PEH536YAC2470M(1)
450	68	AE	22 x 40	0.6	4.4	1100	580	PEH536YAE2680M(1)
450	68	BC	25 x 30	0.6	4.1	1100	580	PEH536YBC2680M(1)
450	100	AF	22 x 45	0.7	5.4	720	390	PEH536YAF3100M(1)
450	100	BD	25 x 35	0.7	5.2	730	400	PEH536YBD3100M(1)
450	120	AG	22 x 50	0.8	6.0	600	330	PEH536YAG3120M(1)
450	150	BF	25 x 45	0.9	6.7	490	270	PEH536YBF3150M(1)
450	150	CD	30 x 35	1.0	7.2	480	260	PEH536YCD3150M(1)
450	180	CE	30 x 40	1.1	8.2	400	220	PEH536YCE3180M(1)
450	220	CF	30 x 45	1.3	9.3	330	180	PEH536YCF3220M(1)
450	220	DE	35 x 40	1.3	9.4	330	180	PEH536YDE3220M(1)
450	270	CG	30 x 50	1.4	10.4	270	150	PEH536YCG3270M(1)
450	270	DF	35 x 45	1.5	10.7	270	150	PEH536YDF3270M(1)
450	330	DG	35 x 50	1.7	11.9	220	120	PEH536YDG3330M(1)
450	390	DH	35 x 55	1.9	13.2	190	100	PEH536YDH3390M(1)
450	470	DI	35 x 60	2.1	14.5	160	86	PEH536YDI3470M(1)
450	560	EI	40 x 60	2.4	16.0	130	73	PEH536YEI3560M(1)
450	680	EK	40 x 70	2.7	17.9	110	61	PEH536YEK3680M(1)
450	1000	EQ	40 x 100	3.4	21.9	75	42	PEH536YEQ4100M(1)
VDC	Rated Capacitance	Size Code	Case Size	Ripple Current		ESR		Part Number

(1) Termination code: See Termination Tables for available options.

Mechanical Data

The capacitor may be mounted in any position. PEH536 is supplied with an insulation sleeve. Voltage proof of the insulation sleeve = 2.5 kVDC (1 min). The minus pole is marked on the case surface. UL recognized sleeving is available for custom parts in this range, upon request. (UL No. E358957)

Marking

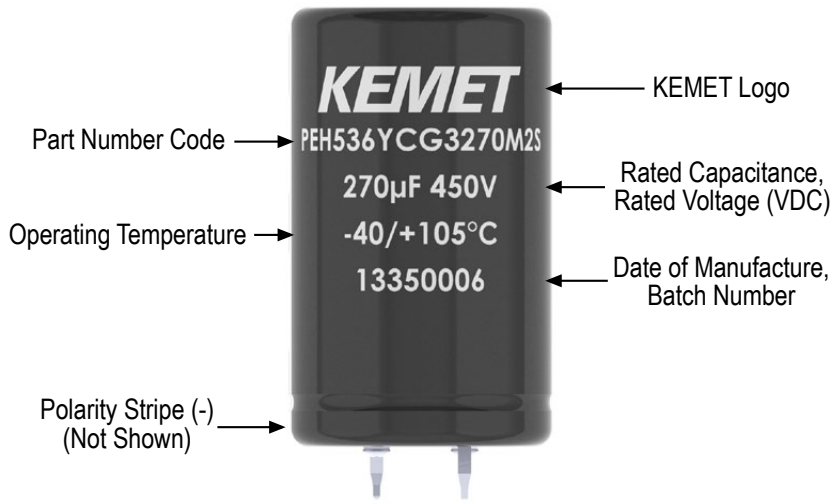

Construction

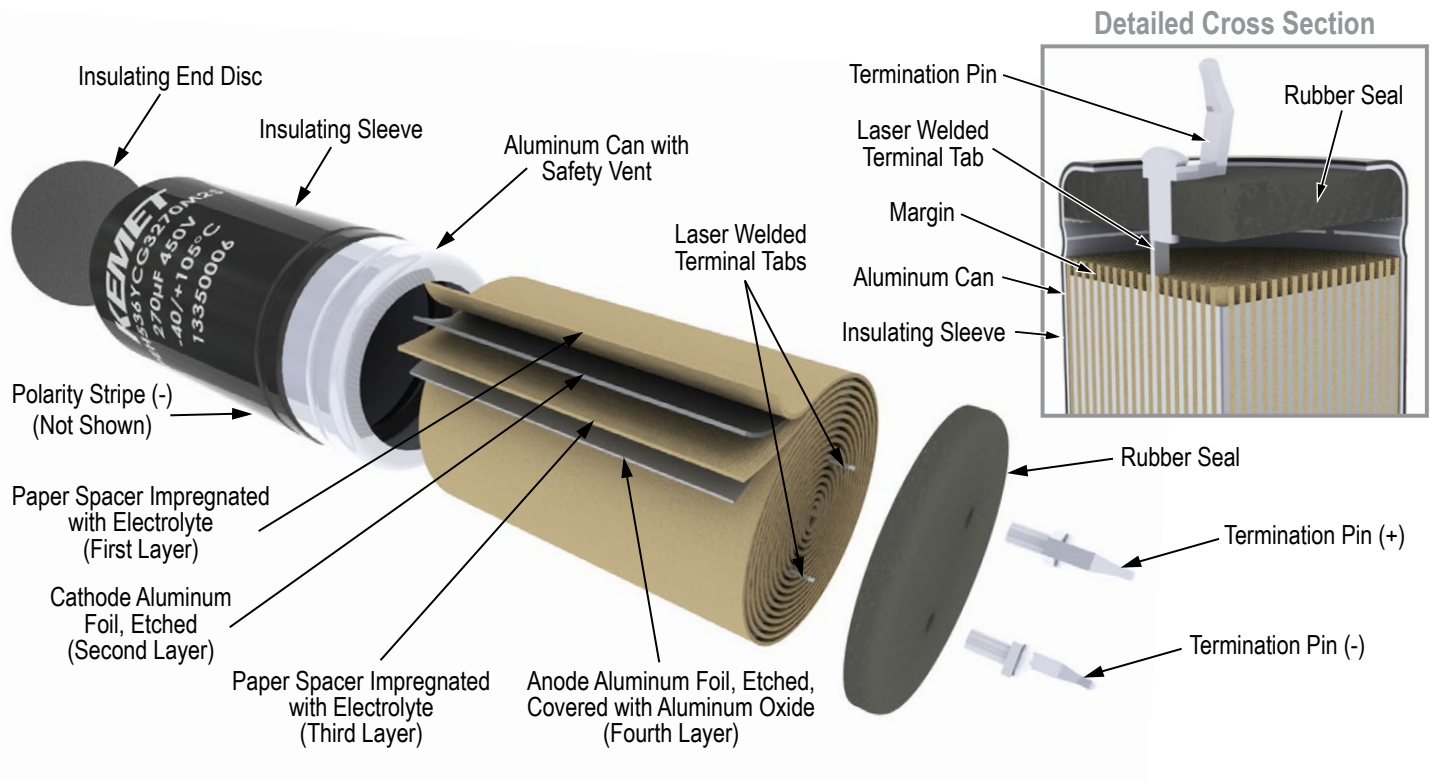

Construction cont'd

The manufacturing process begins with the anode foil being electrochemically etched to increase the surface area and then “formed” to produce the aluminum oxide layer. Both the anode and cathode foils are then interleaved with absorbent paper and wound into a cylinder. During the winding process, aluminum tabs are attached to each foil to provide the electrical contact.

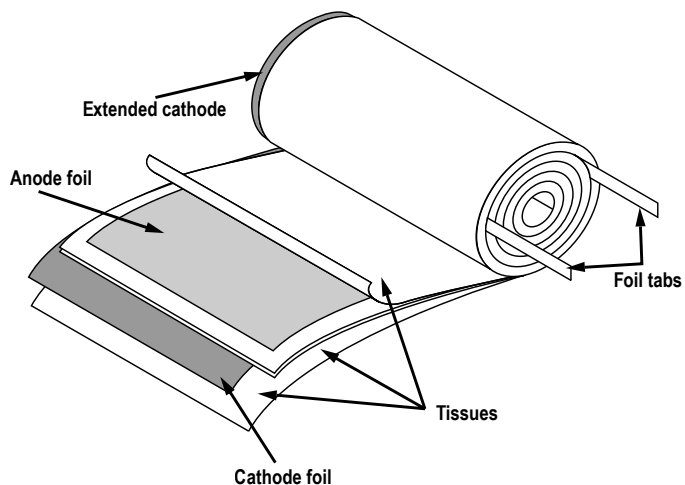

The deck, complete with terminals, is attached to the tabs and then folded down to rest on top of the winding. The complete winding is impregnated with electrolyte before being housed in a suitable container, usually an aluminum can, and sealed. Throughout the process, all materials inside the housing must be maintained at the highest purity and be compatible with the electrolyte.

Each capacitor is aged and tested before being sleeved and packed. The purpose of aging is to repair any damage in the oxide layer and thus reduce the leakage current to a very low level. Aging is normally carried out at the rated temperature of the capacitor and is accomplished by applying voltage to the device while carefully controlling the supply current. The process may take several hours to complete.

Damage to the oxide layer can occur due to variety of reasons:

- Slitting of the anode foil after forming
- Attaching the tabs to the anode foil
- Minor mechanical damage caused during winding

A sample from each batch is taken by the quality department after completion of the production process.

The following tests are applied and may be varied at the request of the customer. In this case the batch, or special procedure, will determine the course of action.

Electrical:

- Leakage current
- Capacitance
- ESR
- Impedance
- Tan Delta

Mechanical/Visual:

- Overall dimensions
- Torque test of mounting stud
- Print detail
- Box labels
- Packaging, including packed quantity

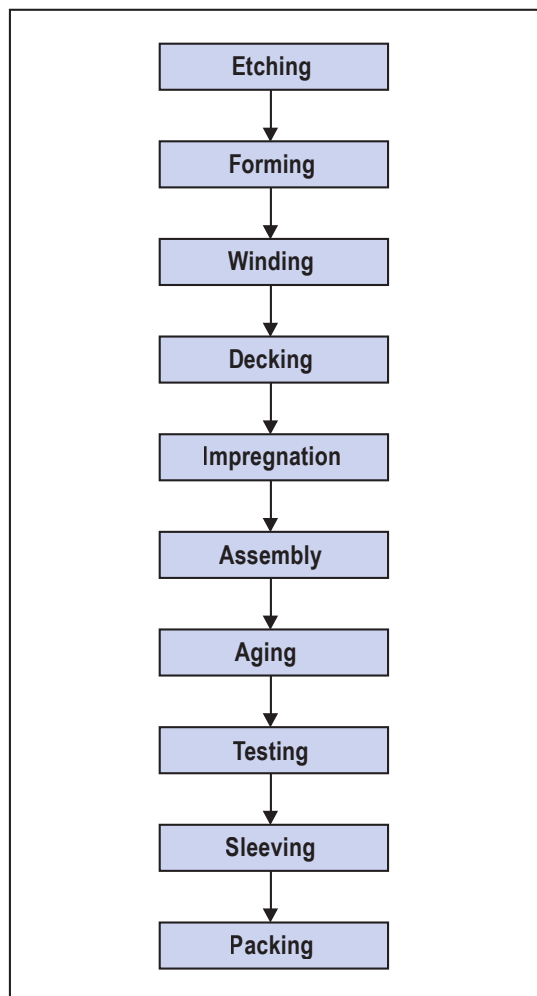

KEMET Corporation World Headquarters

2835 KEMET Way
Simpsonville, SC 29681

Mailing Address:
P.O. Box 5928
Greenville, SC 29606

www.kemet.com
Tel: 864-963-6300
Fax: 864-963-6521

Corporate Offices
Fort Lauderdale, FL
Tel: 954-766-2800

North America

Northeast

Wilmington, MA
Tel: 978-658-1663

Southeast

Lake Mary, FL
Tel: 407-855-8886

Central

Novi, MI
Tel: 248-994-1030

Irving, TX
Tel: 972-915-6041

West

Milpitas, CA
Tel: 408-433-9950

Mexico

Guadalajara, Jalisco
Tel: 52-33-3123-2141

Europe

Southern Europe

Sasso Marconi, Italy
Tel: 39-051-939111

Skopje, Macedonia
Tel: 389-2-55-14-623

Central Europe

Landsberg, Germany
Tel: 49-8191-3350800

Kamen, Germany
Tel: 49-2307-438110

Northern Europe

Wyboston, United Kingdom
Tel: 44-1480-273082

Espoo, Finland
Tel: 358-9-5406-5000

Asia

Northeast Asia

Hong Kong
Tel: 852-2305-1168

Shenzhen, China
Tel: 86-755-2518-1306

Beijing, China
Tel: 86-10-5877-1075

Shanghai, China
Tel: 86-21-6447-0707

Seoul, South Korea
Tel: 82-2-6294-0550

Taipei, Taiwan
Tel: 886-2-27528585

Southeast Asia

Singapore
Tel: 65-6701-8033

Penang, Malaysia
Tel: 60-4-6430200

Bangalore, India
Tel: 91-806-53-76817

Note: KEMET reserves the right to modify minor details of internal and external construction at any time in the interest of product improvement. KEMET does not assume any responsibility for infringement that might result from the use of KEMET Capacitors in potential circuit designs. KEMET is a registered trademark of KEMET Electronics Corporation.

Disclaimer

All product specifications, statements, information and data (collectively, the "Information") in this datasheet are subject to change. The customer is responsible for checking and verifying the extent to which the Information contained in this publication is applicable to an order at the time the order is placed.

All Information given herein is believed to be accurate and reliable, but it is presented without guarantee, warranty, or responsibility of any kind, expressed or implied.

Statements of suitability for certain applications are based on KEMET Electronics Corporation's ("KEMET") knowledge of typical operating conditions for such applications, but are not intended to constitute – and KEMET specifically disclaims – any warranty concerning suitability for a specific customer application or use. The Information is intended for use only by customers who have the requisite experience and capability to determine the correct products for their application. Any technical advice inferred from this Information or otherwise provided by KEMET with reference to the use of KEMET's products is given gratis, and KEMET assumes no obligation or liability for the advice given or results obtained.

Although KEMET designs and manufactures its products to the most stringent quality and safety standards, given the current state of the art, isolated component failures may still occur. Accordingly, customer applications which require a high degree of reliability or safety should employ suitable designs or other safeguards (such as installation of protective circuitry or redundancies) in order to ensure that the failure of an electrical component does not result in a risk of personal injury or property damage.

Although all product-related warnings, cautions and notes must be observed, the customer should not assume that all safety measures are indicated or that other measures may not be required.

X-ON Electronics

Largest Supplier of Electrical and Electronic Components

Click to view similar products for [Aluminium Electrolytic Capacitors - Snap In](#) category:

Click to view products by [Kemet](#) manufacturer:

Other Similar products are found below :

[227LBA250M2BD](#) [MAL215969181E3](#) [ALC40F1012DH](#) [ALC40E1004EL](#) [LGZ2W101MELB30](#) [LGZ2W121MELB35](#) [LGZ2W151MELB40](#)
[LGZ2W820MELB25](#) [LGZ2W221MELB50](#) [LGZ2W271MELC45](#) [LGZ2W221MELC40](#) [LGZ2W331MELC50](#) [LGZ2W151MELC30](#)
[LGZ2W181MELC35](#) [LGZ2W121MELC25](#) [HC1C339M30040HA](#) [HC1E109M25030HA](#) [HC1J109M30050HA](#) [HC1V229M35045HA](#)
[HC2G227M25040HA101](#) [HC2G337M30040HA](#) [HE1E229M30045HA](#) [HE1H109M35040HA](#) [HE1J478M25040HA](#) [HE1J688M35040HA](#)
[HE2A228M30040HA](#) [HE2E227M22030HA](#) [HE2E477M25040HA](#) [HE2E477M30030HA](#) [HE2G107M30025HA](#) [HE2G227M30045HA](#)
[380LX101M500H452](#) [382LX152M250A052](#) [382LX152M450B082VS](#) [382LX183M100B082VS](#) [382LX223M080B062VS](#)
[382LX223M100B092VS](#) [382LX333M080B092VS](#) [383LX223M080B092VS](#) [HP 1000U/63V](#) [HP 100U/450V](#) [382LX153M100B062VS](#)
[382LX222M400B092VS](#) [382LX223M063N082](#) [383LX153M063A062](#) [383LX153M080N082](#) [383LX333M050B052VS](#) [383LX471M450A052](#)
[400VXH150MEFCSN25X25](#) [LGX2H151MELA45](#)