

Overview

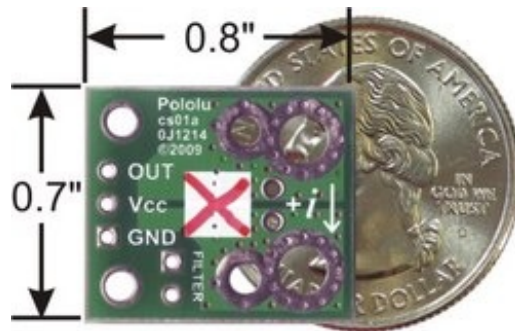

This current sensor is a carrier board or breakout board for Allegro's ACS714LLCTR-30A-T Hall effect-based linear current sensor; we therefore recommend careful reading of the ACS714 datasheet (678k pdf) before using this product. The sensor operates at 5 V and has an output sensitivity of 66 mV/A. The board ships fully populated with its SMD components, including the ACS714, as shown in the product picture. The following list details some of the sensor's key features:

- **Designed for bidirectional input current from -30 A to 30 A (though the robust sensor IC can survive up to five times the overcurrent condition).**
- **Conductive path internal resistance is typically 1.2 m Ω , and the PCB is made with 2-oz copper, so very little power is lost in the board.**
- **Use of a Hall effect sensor means the IC is able to electrically isolate the current path from the sensor's electronics (up to 2.1 kV RMS), which allows the sensor to be inserted anywhere along the current path and to be used in applications that require electrical isolation.**
- **80 kHz bandwidth that can optionally be decreased by adding a capacitor across the board pins marked "filter".**
- **High accuracy and reliability: typical total output error of $\pm 1.5\%$ at room temperature with factory calibration, an extremely stable output offset voltage, and almost zero magnetic hysteresis.**
- **Automotive-grade operating temperature range of -40°C to 150°C .**

The pads are labeled on the bottom silkscreen, as shown in the picture to the right. The silkscreen also shows the direction that is interpreted as positive current flow via the **+i** arrow.

This version is marked with a red X. We also sell a 30A unidirectional version and a $\pm 5\text{A}$ bidirectional version of this board; you can distinguish these versions by reading the text on the IC or by looking at the color of the X on the bottom silkscreen.

Using the sensor

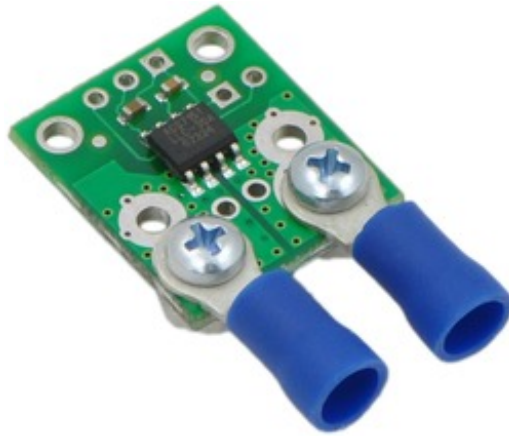

ACS715 current sensor carrier with solderless ring terminal connectors (not included).

Electrical connections

The sensor requires a supply voltage of 4.5 V to 5.5 V to be connected across the Vcc and GND pads, which are labeled on the bottom silkscreen. The sensor outputs an analog voltage that is linearly proportional to the input current. When Vcc is 5 V, this output voltage is centered at 2.5 V and changes by 66 mV per amp of input current, with positive current increasing the output voltage and negative current decreasing the output voltage.

Warning: This product is intended for use below 30 V. Working with higher voltages can be extremely dangerous and should only be attempted by qualified individuals with appropriate equipment and protective gear.

The input current can be connected to the board in a variety of ways. For low-current applications, you can solder 0.1" male header pins to the board via the small through-holes on the input-current side of the board. For higher-current applications, you can solder wires directly to the through-holes whose sizes best match your wires, or you can use solderless ring terminal connectors, as shown in the picture to the right. The large through-holes are big enough for #6 screws.

Mounting information

The board has two mounting holes on the logic side of the board. These mounting holes are 0.5" apart and are designed for #2 screws.

Filtering the output

The IC has an internal filter resistance of 1.7 k Ω , and the carrier board includes a 1 nF filter capacitor, which produces a low-pass RC filter with a 90 kHz cutoff. You can improve sensing system accuracy for low-frequency sensing applications by adding a capacitor in parallel with the integrated 1 nF capacitor across the pads marked "filter" on the bottom silkscreen (this capacitor is labeled C2b in the schematic below). The frequency **F** that the filter will attenuate to half its original power is given by:

$$F = 1 / (2\pi RC) = 1 / (11k\Omega * (1 \text{ nF} + C_f))$$

where **Cf** is the value of the capacitor added to the filter pads.

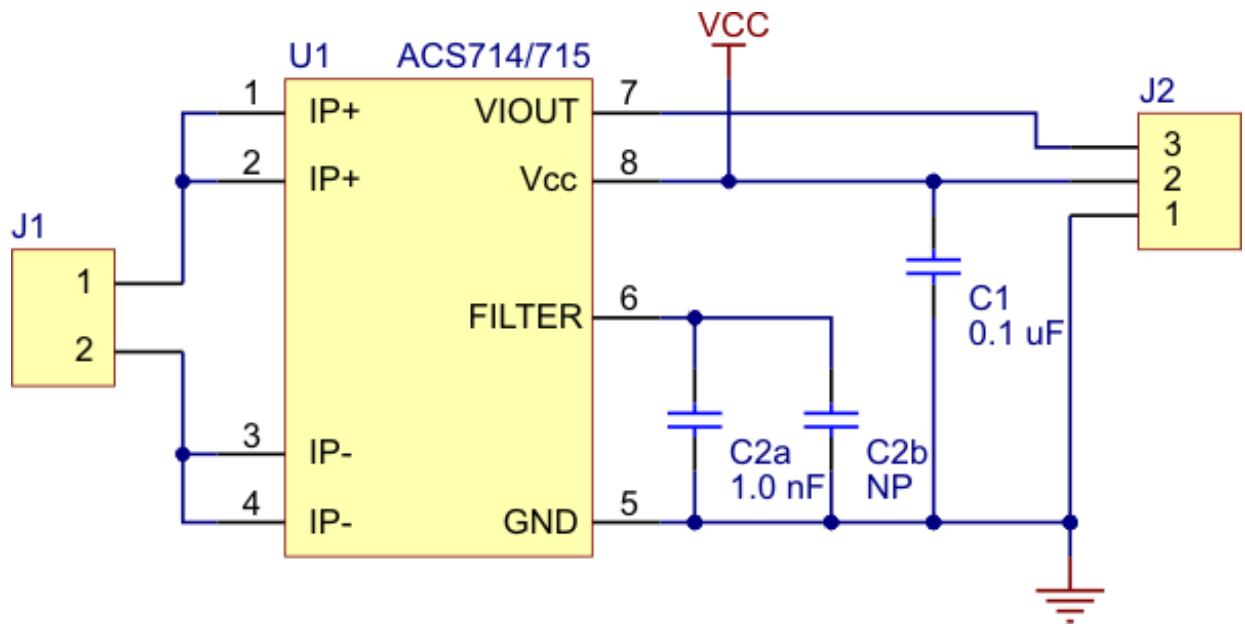

Pololu ACS714/ACS715 current sensor carrier schematic diagram.

[Documentation on producer website.](#)

X-ON Electronics

Largest Supplier of Electrical and Electronic Components

Click to view similar products for [Other Sensors](#) category:

Click to view products by [Pololu](#) manufacturer:

Other Similar products are found below :

[OKY3471-5](#) [OKY3511-1](#) [DFR0029-B](#) [DFR0029-W](#) [DFR0423](#) [SEN0156](#) [POLOLU-1185](#) [DFR0107](#) [DFR0129](#) [FIT0212](#) [SEN0047](#)
[SEN0065](#) [SEN0068](#) [SEN0086](#) [SEN0098](#) [SEN0104](#) [SEN0187](#) [SEN0202](#) [SEN0213](#) [SEN0217](#) [SEN0160](#) [SEN0203](#) [SEN0209](#) [OKY3103](#)
[OKY3222](#) [OKY3222-1](#) [OKY3271-1](#) [OKY3273](#) [OKY3276](#) [OKY3276-1](#) [OKY3278](#) [OKY3311](#) [OKY3312-20A](#) [OKY3317-20A](#) [OKY3319](#)
[OKY3420](#) [OKY3420-1](#) [OKY3420-2](#) [OKY3420-3](#) [OKY3420-4](#) [OKY3421](#) [OKY3422](#) [OKY3423](#) [OKY3427](#) [OKY3428](#) [OKY3430](#) [OKY3433](#)
[OKY3433-3](#) [OKY3434](#) [OKY3435](#)