

36-position Quadrature Encoder Set (#29321)

The Parallax 36-position Quadrature Encoder Set conveniently provides rotational feedback for robot wheels. This set was designed specifically for the Motor Mount and Wheel Kit (#27971), which is included with the Eddie and MadeUSA robotic platforms. Or, use this kit with your own custom robots or mechanical systems with ½" axles.

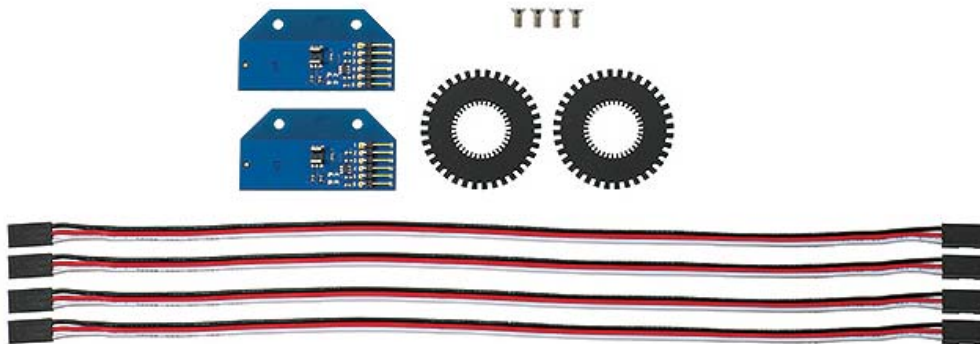

Features

- Provides two out-of-phase outputs from within a single sensor assembly
- 36-position Delrin encoder disks are incised to grip ½" diameter axles
- Dual-signal out-of-phase outputs indicate direction, pulse widths indicate speed, and number of pulses indicates distance traveled
- Small form-factor and low voltage/current operation are easy to integrate with your robotic system
- 6-pin single row header with 0.1" spacing provides a simple 4-wire or dual 3-wire interface

Specifications

- Power requirements: 2.5 VDC @ 3.5 mA, 3.0 VDC @ 5.0 mA, 11.6 ma @ 5.5 VDC max.
- Communication: two-channel high/low pulse output
- Dimensions: 2.0 x 1.1 x .25 in (5.1x 2.7 x 0.6 cm)
- Operating temp.: 32–158 °F (0–70 °C)

Kit Contents

- (2) Quadrature Encoder circuit boards
- (2) Encoder disks, 36-position
- (4) 3-wire extension cables, 12"
- (4) flat-head screws, #40-40, ¼"

Tools Required

- Small Philips screwdriver
- Craft knife

How it Works

The Quadrature Encoder employs a dual-slotted sensor mounted on a printed circuit board (PCB). This module contains a single infrared light source on one side of its slot, and two separate sensors embedded into the opposite side of the slot.

When the encoder disk rotates and swings through the slot, each individual fin on the disk blocks one sensor first, and then the other, from the light source. The first blocked sensor transitions from low to high, and then, as the encoder disk continues to rotate, the second sensor is blocked and it too transitions from low to high. These two signals overlap each other.

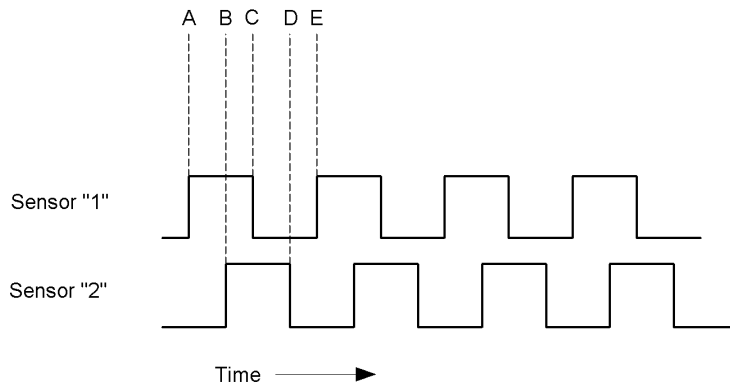

As shown above, this means that after sensor 1 goes high (A), sensor 2 then goes high (B) as the encoder continues to rotate. Then, as the encoder continues to spin, sensor 1 goes low (C), and then sensor 2 follows (D). Because sensor 1 went high before sensor 2 (A to B), it indicates that the encoder disk is rotating in one direction (in the case of a robot, either forward or reverse). If sensor 2 went high before sensor 1, then the disk is rotating in the opposite direction.

By interpreting these two signals, the following can be determined:

- a) Whether or not the device is moving, by detecting transitions on either sensor
- b) The direction in which the device is moving, by detecting which sensor transition occurs first
- c) The speed at which the device is moving, by measuring the widths of each pulse or by measuring the frequency of the pulses
- d) The total distance traveled, by counting the number of pulses from either sensor

Assembly Instructions

Step 1: Using a small knife or toothpick, clean out any small pieces of plastic that may still be between the internal fins of the encoder disk. Then, gently push the disk onto the axle as shown below. The internal fins will deform and tightly grip the axle.

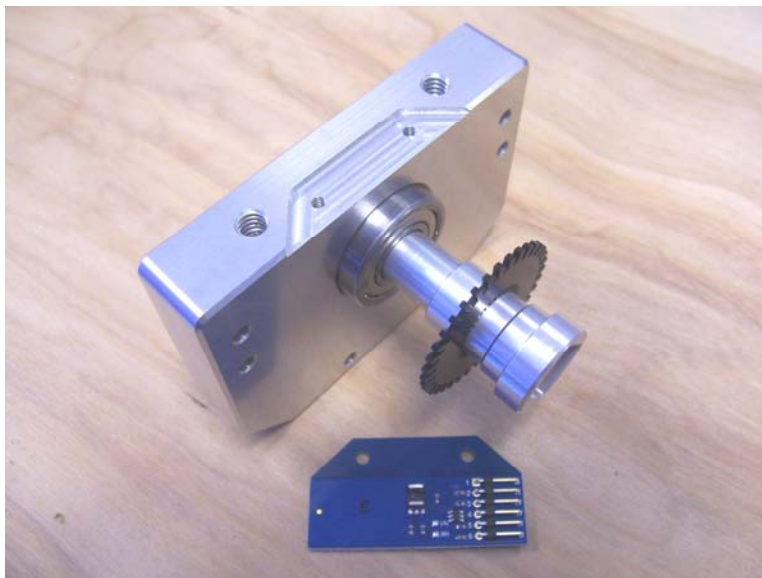

Step 2: Next insert the bearing and axle into the Motor Mount block. Be sure to fully-seat the bearing into the block as shown below.

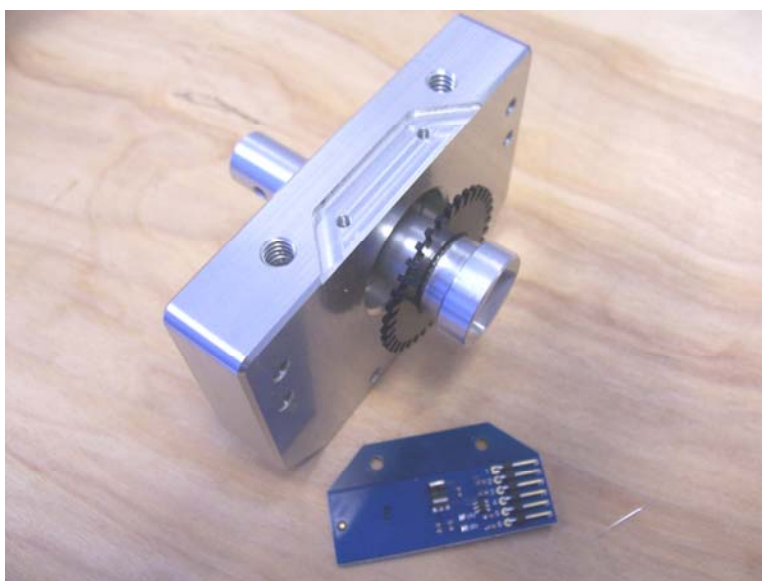

Step 3: Mount the Encoder board to the Motor Block, using the two flat-head screws provided. Be sure to align the board such that the Encoder disk fits between the slots of the encoder sensor on the PCB, as shown below.



Step 4: Last, connect the two cables. Black wires should be towards the outside and the white wires should be next to each other in the center of the assembly, as shown below.

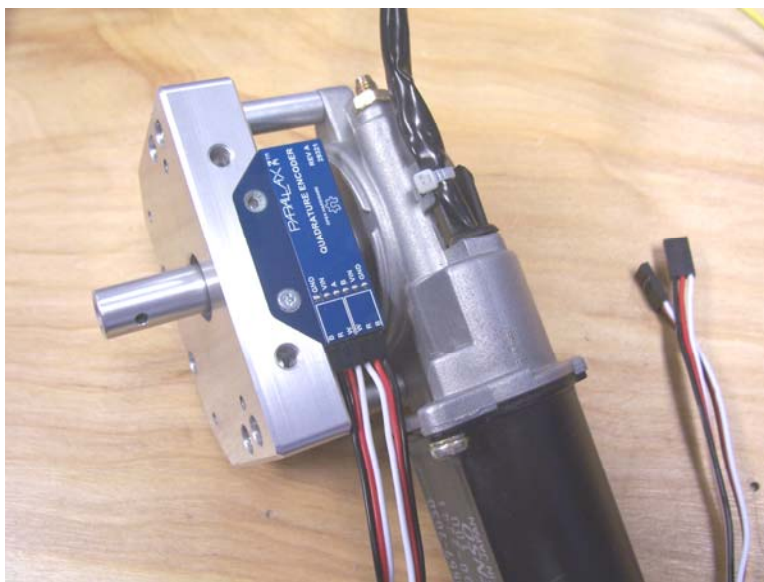
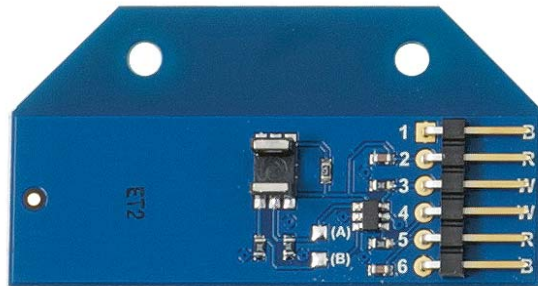

X-ON Electronics

Largest Supplier of Electrical and Electronic Components

Click to view similar products for [Encoders](#) category:

Click to view products by [Parallax](#) manufacturer:

Other Similar products are found below :

[6-1393048-5](#) [62AG22-H5-P](#) [62B22-LP-030C](#) [62D22-02-P](#) [62R22-01-040S](#) [63K25](#) [63K32](#) [63KS100](#) [63KS64](#) [63R100](#) [63R50-020](#) [63RS256-060](#) [700-09-36](#) [E6C2-CWZ6C-10 500P/R 5M](#) [E6C3-CWZ5GH 1000P/R 2M](#) [25LB22-G-Z](#) [T101-5C2-111-M1](#) [T101-5C3-111-M1](#) [T101-5C4-111-M1](#) [25LB45-Q-Z](#) [HEDS-8905](#) [385001M0439](#) [385001M0216](#) [DPL12SV2424A25K3](#) [E69-1](#) [E69-DF15](#) [E69-FBA-02](#) [E69-FCA](#) [E6B2-CWZ1X 2000P/R 0.5M](#) [E6B2-CWZ3E 600P/R 0.5M](#) [E6C3-CWZ3EH 800P/R 2M](#) [ENA1D-472-L00050L](#) [61S64-2](#) [62B11-LP-100S](#) [62B11-LPP-P](#) [62C1111-02-020C](#) [62N11-P](#) [62S22-H9-120S](#) [62S30-L0-200C](#) [62V15-02-080S](#) [62V22-02-030C](#) [632911-128](#) [63K64](#) [63KS100-040](#) [63R64-050](#) [63RS256](#) [63RS64](#) [700-16-16](#) [3-1393048-1](#) [63KS128](#)