



# GTS-4E Hardware User Manual

Version: V1.1.0

Date: 2013-12-04



## Confidential Material

This document contains information highly confidential to Fibocom Wireless Inc. (Fibocom). Fibocom offers this information as a service to its customers, to support application and engineering efforts that use the products designed by Fibocom. The information provided is based upon requirements specifically provided to Fibocom by the customers. All specifications supplied herein are subject to change. Disclosure of this information to other parties is prohibited without the written consent of Fibocom.

## Copyright

Copy, Reproduce, Distribute and/or Edit of this document or part of it as well as utilization of its contents and communication thereof to others without express authorization are prohibited. Offenders will be held liable for payment of damages. All rights created by patent grant or registration of a utility model or design patent are reserved. Copyright ©2013 Fibocom Wireless Inc. All rights reserved.

## Trademarks Notice



The FIBOCOM Logo is registered by Fibocom Wireless Inc. All other product or service names or logos are the property of their respective owners. Copyright ©2013 Fibocom Wireless Inc. All rights reserved.

## Revision History

Version	Date	Remarks
V1.0.0	2011-01-04	Initial Version
V1.0.1	2011-08-06	Add hardware design, change some descriptions
V1.0.2	2012-01-06	Add GTS-4E-6x2, add recommended circuit
V1.0.3	2012-03-27	Update the mechanical specifications
V1.0.4	2012-06-25	Delete ATP and APM
V1.0.5	2013-05-03	1. Delete GTS-4E-00 and GTS-4E-10, add GTS-4E-70 2. Add product features 3. Delete PCB layout 4. Update block diagram
V1.0.6	2013-05-20	Add Horizontal Accuracy
V1.0.7	2013-06-13	Modify the voltage of interface
V1.0.8	2013-07-05	Add GTS-4E-50, Update the name of the document
V1.0.9	2013-10-08	Add NMEA and Pin definition Delete baud rate description of GTS-4E-70

V1.1.0	2013-12-04	Update descriptions about \$PSRF in section 2.6 Update description about active antenna in section 5.1.2 Update description about baud rate configuration in section 3.2
--------	------------	--

## Applicability Table

No.	Type	SPI	UART	Note
1	GTS-4E-50	Supported	Not supported	It doesn't support ON_OFF、RESET and IPPS function.
2	GTS-4E-60	Not supported	Supported	
3	GTS-4E-70	Supported	Not supported	

## Contents

1	Preface .....	6
2	Overview .....	7
2.1	Description .....	7
2.2	GPS Performance .....	7
2.3	Block Diagram .....	8
2.4	SPI Interface .....	8
2.5	UART Interface .....	9
2.6	Protocols .....	10
2.7	Power .....	10
2.7.1	Power Signal .....	10
2.7.2	Working Mode .....	11
2.8	Control Signal .....	11
2.8.1	ON_OFF .....	11
2.8.2	RESET .....	11
2.8.3	1PPS .....	12
3	Hardware Description .....	13
3.1	Pin Definition .....	13
3.2	Baud Rate .....	15
3.3	Recommended PCB Layout and Stencil Design .....	15
3.4	Mechanical Specifications .....	17
4	Electrical Features .....	18
4.1	Absolute Maximum Ratings .....	18
4.2	Pin Level .....	18
5	Antenna .....	19
5.1	Active Antenna .....	19
5.1.1	Supplied by External Power .....	19
5.1.2	Supplied by Internal Power .....	20
5.2	Passive Antenna .....	20
5.3	ESD Precautions for Antennas .....	21

# 1 Preface

This document mainly introduces technical details about GTS-4E serials GPS modules.

## 2 Overview

This chapter gives a general description of the GPS Module.

### 2.1 Description

The GTS-4E is a new generation of GPS receiving module. It has the following features:

- Capture the GPS signals quickly
- Ultra-high sensitivity
- Strong anti-jamming performance
- LCC mounting
- Lower power consumption

GTS - 4E serial module is widely be used in monitoring, positioning, mapping, navigation, security applications, and other fields.

### 2.2 GPS Performance

Parameter	Specification	
Receiver Type	48 Channels, Tracking L1, C/A code	
Time-To-First-Fix*	Cold Start (autonomous)	35s
	Hot Start(autonomous)	1s
Horizontal Accuracy	2.5m	
Sensitivity*	Tracking	-161dBm
	Acquisition	-147dBm
Accuracy of Timepulse Signal	RMS	100ms
Power Consumption*	Acquisition	54mA
	Navigation	33mA
	Sleep Mode	550uA
	Deep Sleep Mode	200uA
Max Navigation Update Rate	1Hz	
Interface	UART	9600bps
Weight	≤1g	
Size (L x W x H)	16.0mm x 12.2mm x 2.6mm	
Operational Limits	Altitude	18000m
	Velocity	500m/s

**Note:** Parameters with "\*" mark means typical value.

## 2.3 Block Diagram

The following figure shows the block diagram of GTS-4E:

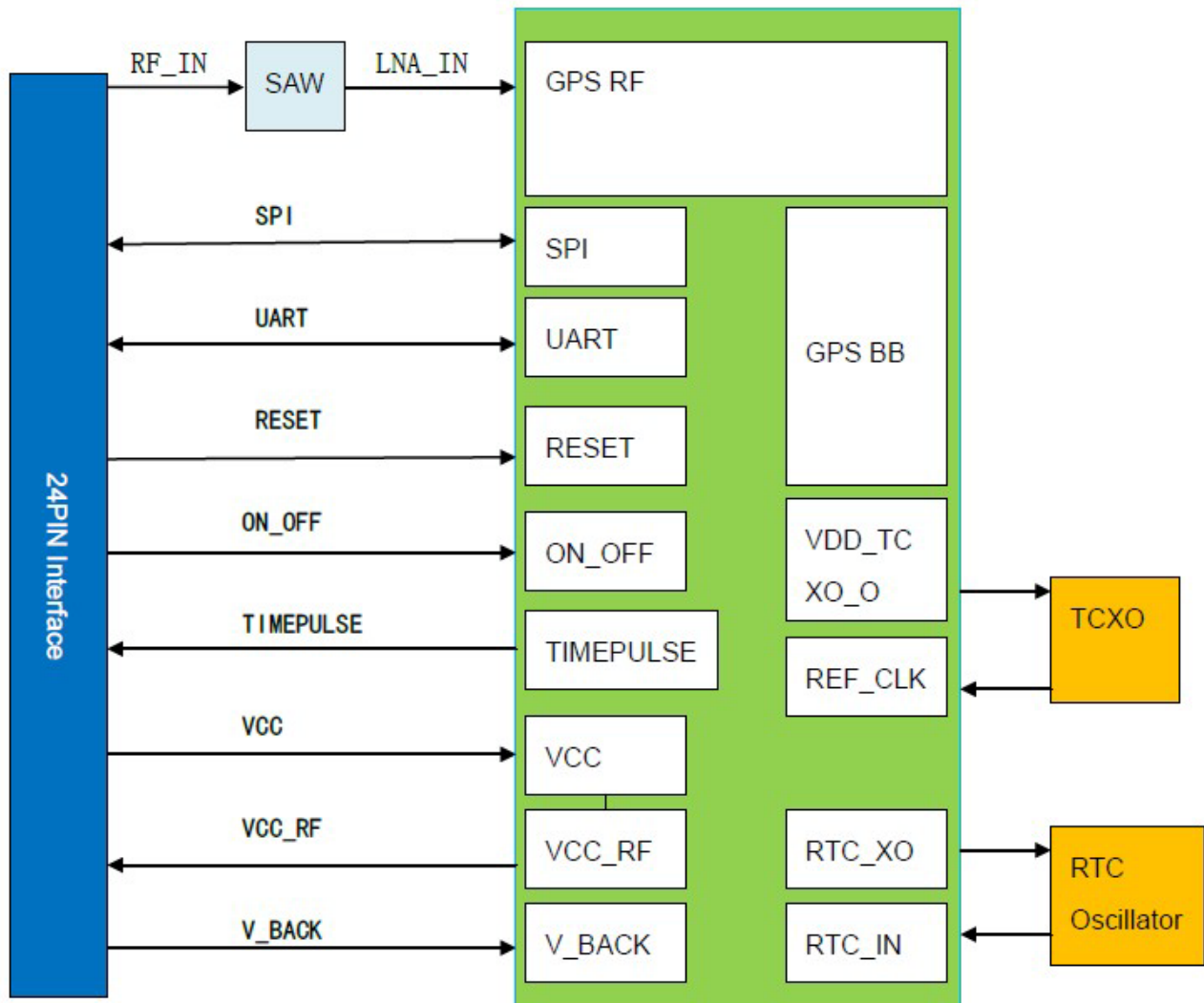

Figure 2-1 GTS-4E Block Diagram

## 2.4 SPI Interface

Pin description for SPI interface:

Pin Name	Pin Description
SPI_MISO	Module SPI interface output
SPI_MOSI	Module SPI interface input
SS_N	Module SPI interface chip selection
SPI_CLK	Module SPI interface clock



SPI interface connection:

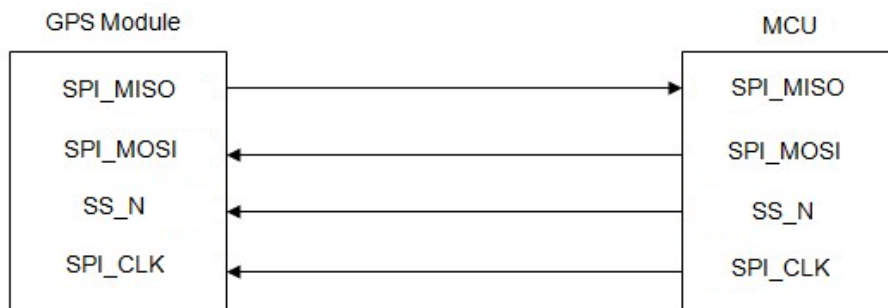

Figure 2-2 SPI Interface Connection

Slave mode: GPS module is slave, MCU is master.

Maximum clock frequency is 6.8MHz, recommended frequency range: 100 KHz-1.5MHz.

When powered on, SPI\_CLK is high impedance.

Data is captured on the falling edge of the clock signal, triggered on the rising edge of the clock signal.

SPI host port timing diagram:

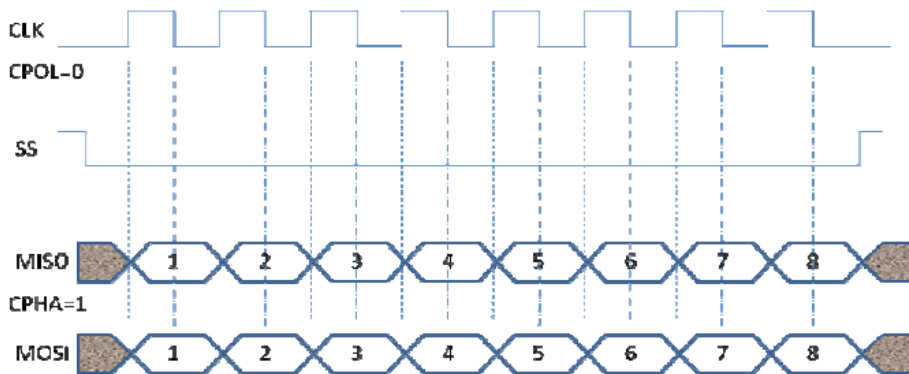

Figure 2-3 SPI host port timing diagram, SPI mode 1(single byte transfer)

## 2.5 UART Interface

Pin description for UART interface:

Pin Name	Pin Description
TXD	Module UART Transmit Data
RXD	Module UART Receive Data

UART interface design:

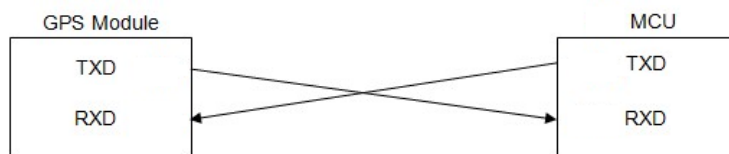

Figure 2-4 UART Interface Connection

## 2.6 Protocols

The GTS-4E module complies with the following protocol:

Protocol	Type
NMEA	NMEA 0183 ASCII, (version 3.01, January 1, 2002)
OSP	SiRF Binary Protocol

The default protocol of GTS-4E is NMEA, and the default configuration of NMEA protocol is : \$GPGGA, \$GPGSA, \$GPRMC output data every second; \$GPGSV output data every 5 seconds;

- Control the message outputs of GGA, GSA and GSV by command \$PSRF103 command
- Switch to SiRF OSP protocol by command \$PSRF100, configure the baud rate by command \$PSRF100, the baud rate can be configured to: 4800, 9600, 19200, 38400, 115200, 230400, 460800, 921600, 1228800, unit: bps; the module restores to the default settings after you restart it.

## 2.7 Power

### 2.7.1 Power Signal

GTS-4E has three power pins: VCC, VCC\_RF and V\_BACK.

Pin description for power pin:

Pin Name	Pin Description
VCC	Main power supply input
VCC_RF	Active antenna power supply output, module connects to the VCC internally.
V_BACK	Standby battery power input, it is used for saving ephemeris.

The range of working voltage:

Pin Name	Minimum Value	Recommended Value	Maximum Value
VCC	2.7 V	3.3 V	5.5 V
V_BACK	2.7 V	3.3 V	5.5 V
VCC_RF	Module connects to the VCC internally.		

The main function of V\_BACK is to supply the power for internal RAM and RTC, so the data in RAM can be saved

The module goes into hot start and warm start status when main power is re-powered on, if the main power is cut off when power is not supplied by V\_BACK, after you re-power on the module, it changes to cold start status.

## 2.7.2 Working Mode

The module supports the following working modes:

Working Mode	Status Description
Capture Mode	VCC enabled, module captures satellite signals.
Navigation Mode	VCC enabled, module goes into navigation mode, TIMEPULSE output 1PPS waveform.
Sleep Mode	VCC disabled, V_BACK keeps enabled, saving ephemeris. It goes into hot start, repositioning quickly.
Deep Sleep Mode	VCC enabled, control ON_OFF timing by software, the module goes into deep sleep mode, and then VCC disabled, V_BACK keeps enabled.
Power off Mode	Disable VCC and V_BACK, goes into power off mode, clear ephemeris, you need to recapture the satellite signals after power on.

## 2.8 Control Signal

### 2.8.1 ON\_OFF

ON\_OFF pin is used for controlling deep sleep of the module; this function is not supported so far.

### 2.8.2 RESET

RST is the reset pin of the module.

After the module is powered on, RST pin is high level, input a 200ms low pulse to Reset pin, the module will reset, as shown in the following figure:



Figure 2-5 Reset Timing

Pulse timing requirements:

Parameter	Minimum Value	Typical Value	Maximum Value	Unit
RESET pulse width	200	300	1000	ms

After reset, packet data stops, after module restarts and positions, packet data restores.

### 2.8.3 1PPS

TIMEPULSE is the output pin for 1PPS signal.

The module goes into navigation mode; the following figure shows the waveform outputs by 1PPS.

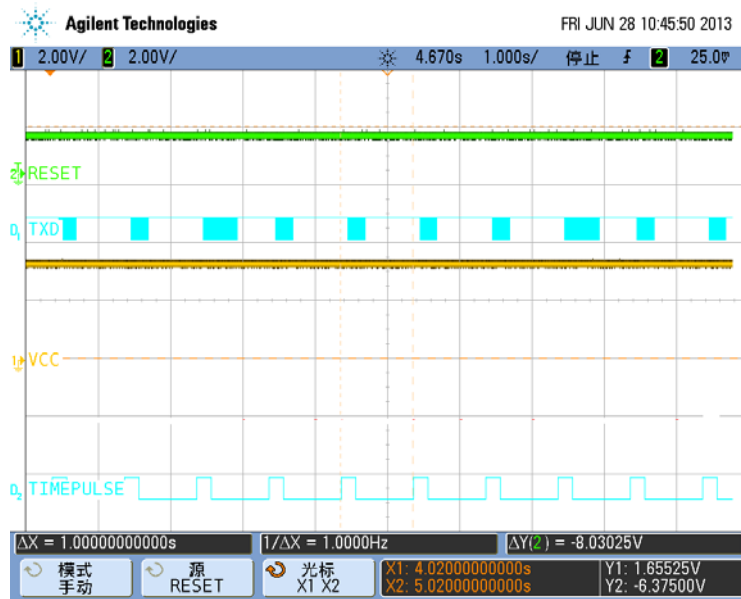

Figure 2-6 1PPS Waveform

# 3 Hardware Description

## 3.1 Pin Definition



Figure 3-1 Pin Definition

No.	Module	Name	I/O	Description
1	ALL	RESERVE		No Connect
2	GTS-4E-70	SS_N	I	SPI Slave Select
	GTS-4E-50	RESERVE		No Connect
3	GTS-4E-70	TIMEPULSE	O	1PPS: one pulse per second after navigated.
	GTS-4E-60	RESERVE		No Connect
4	GTS-4E-70	ON_OFF	I	Power mode control pin, not supported so far, no connect.
	GTS-4E-60	RESERVE		No Connect
5	ALL	RESERVE		No Connect

6	ALL	RESERVE		No Connect
7	ALL	RESERVE		No Connect
8	ALL	RESERVE		No Connect
9	ALL	VCC_RF	O	Output Voltage ,RF Section
10	ALL	GND		Ground
11	ALL	RF_IN	I	GPS Signal Input
12	ALL	GND		Ground
13	ALL	GND		Ground
14	GTS-4E-70 GTS-4E-50	SPI_MOSI	I	SPI MOSI
	GTS-4E-60	RESERVE		No Connect
15	GTS-4E-70 GTS-4E-50	SPI_MISO	I	SPI MISO
	GTS-4E-60	RESERVE		No Connect
16	GTS-4E-70 GTS-4E-50	SPI_CLK	I	SPI Clock
	GTS-4E-60	RESERVE		No Connect
17	GTS-4E-70 GTS-4E-60	RST	I	RESET, pull-up internally ,low level activated
	GTS-4E-50	RESERVE		No Connect
18	GTS-4E-70 GTS-4E-50	RESERVE	I	No Connect
	GTS-4E-60	BAUD_RATE_0		Baud rate configuration
19	GTS-4E-70 GTS-4E-50	RESERVE	I	No Connect
	GTS-4E-60	BAUD_RATE_1		Baud rate configuration
20	GTS-4E-70 GTS-4E-50	RESERVE		No Connect
	GTS-4E-60	TXD	O	Serial Port
21	GTS-4E-70 GTS-4E-50	RESERVE		No Connect
	GTS-4E-60	RXD	I	UART data input
22	ALL	V_BACK	I	Backup Supply Voltage
23	ALL	VCC	I	Supply Voltage
24	ALL	GND		Ground

### 3.2 Baud Rate

The default baud rate of UART interface is 9600bps.

You can configure different baud rate by BAUD\_RATE\_0 and BAUD\_RATE\_1, the following table shows the control logic:

BAUD_RATE_0	BAUD_RATE_1	Protocol	Baud Rate
Pull high	Pull high	NMEA	4800
Pull high	Pull low	NMEA	9600
Pull low	Pull high	NMEA	38400
Pull low	Pull low	OSP	115200

**Note:** The module has the corresponding pull-up and pull-down internally by default (pull-up by high level 1.8V, the resistor is 10KΩ). If you want to change, the external must be strong pull-up and pull-down; the recommended resistor is 1KΩ.

### 3.3 Recommended PCB Layout and Stencil Design

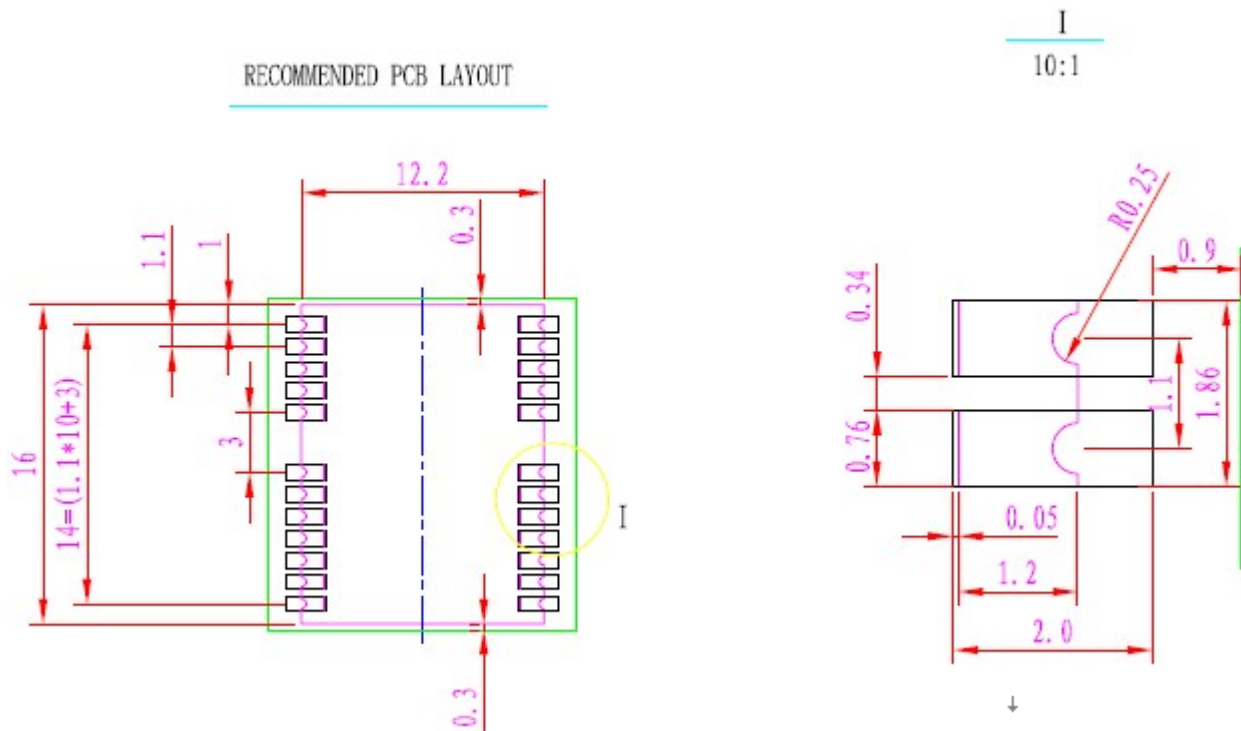

Figure 3-2 Recommended PCB Layout

**Note:** Do not place any component in the green area.

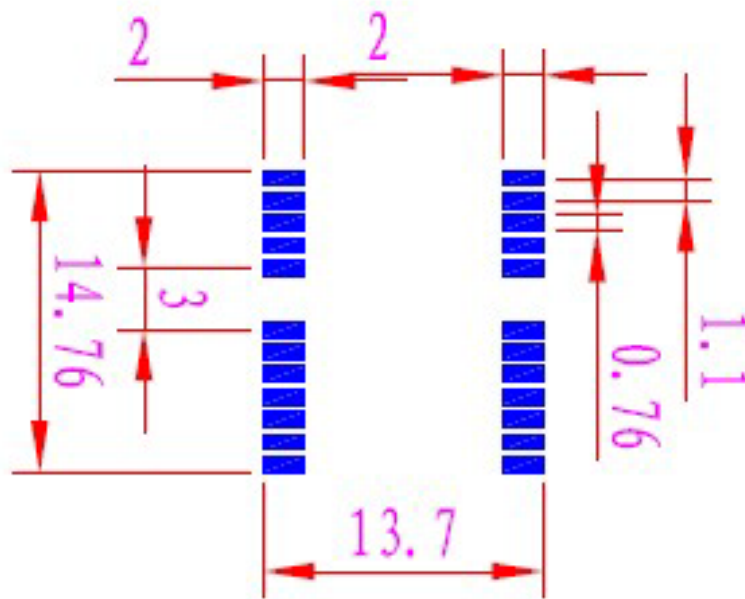

Figure 3-3 Recommended Stencil Design

**Note:**

- The thickness of the stencil: 0.18mm
- The stencil hole should be beyond 0.8mm of PCB pad. This design has been verified. Solder paste will be dragged back to the pad after soldering.



### 3.4 Mechanical Specifications

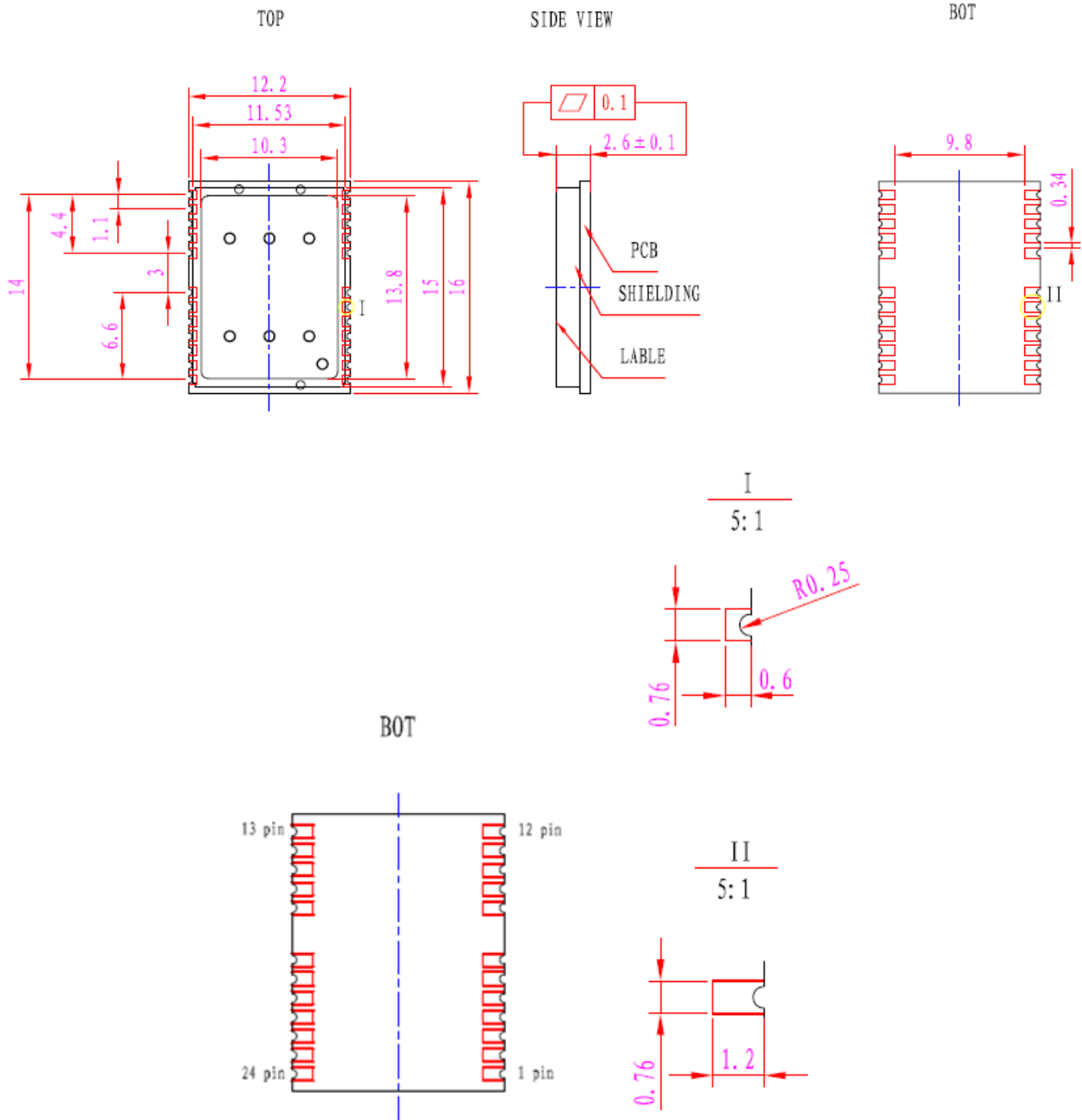

Figure 3-3 Mechanical Specifications

## 4 Electrical Features

### 4.1 Absolute Maximum Ratings

Parameter	Minimum Value	Maximum Value	Units
Power Supply Voltage (VCC)	-0.1	5.5	V
Backup Battery Voltage (V_BACK)	-0.1	5.5	V
Operating Temperature	-40	85	°C
Storage Temperature	-40	85	°C

### 4.2 Pin Level

Pin Name	Parameter	Minimum Value	Maximum Value
TXD	High	2.7V	VCC
	Low	-0.3V	0.3V
RXD	High	1.71V	3.6V
	Low	-0.3V	0.3V
SPI_MISO	High	2.7V	VCC
	Low	-0.3V	0.3V
SPI_MOSI	High	1.71V	3.6V
	Low	-0.3V	0.3V
SS_N	High	1.71V	3.6V
	Low	-0.3V	0.3V
SPI_CLK	High	1.71V	3.6V
	Low	-0.3V	0.3V
ON_OFF	High	1.71V	1.89V
	Low	-0.3V	0.3V
RST	High	1.71V	1.89V
	Low	-0.3V	0.3V
BUAD_RATE_0	High	1.71V	3.6V
	Low	-0.3V	0.3V
BUAD_RATE_1	High	1.71V	3.6V
	Low	-0.3V	0.3V

# 5 Antenna

GTS-4E modules are compatible with passive antennas and active antennas.

Parameter	Specification
Impedance	50 ohm
Frequency Point	1575.42MHz
Bandwidth	2.046MHz
Antenna Type	Passive antenna or active antenna
Antenna Power Supply	Using VCC_RF or external voltage, VCC_RF connects to VCC inside the module.
Active Antenna Recommendations	Minimum Gain: 15dB
	Maximum Noise Figure: 1.5 dB
	Maximum Gain: 28dB

## 5.1 Active Antenna

### 5.1.1 Supplied by External Power

RF\_IN power is supplied by External Power; the following figure shows the reference design:

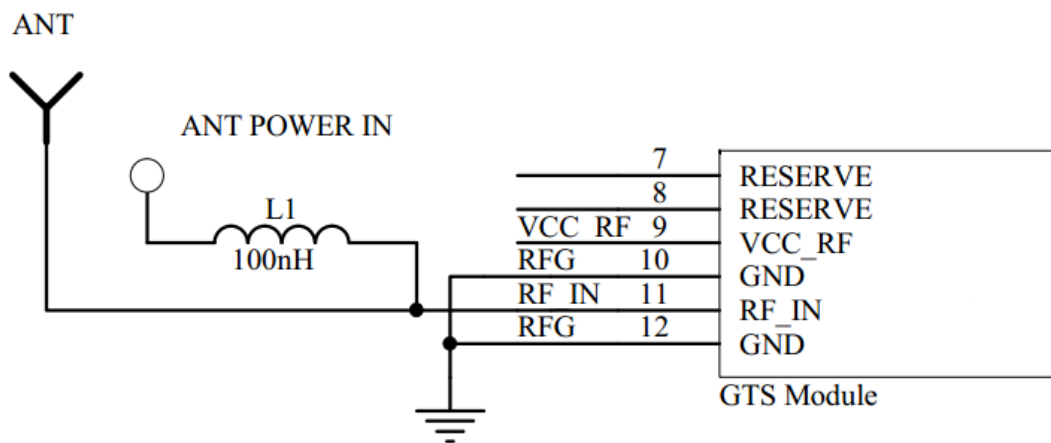

Figure 5-1 Supplied by External Power

### 5.1.2 Supplied by Internal Power

RF\_IN power is supplied by VCC\_RF of GPS module, VCC\_RF is connected to VCC internally, and the following figure shows the reference design:

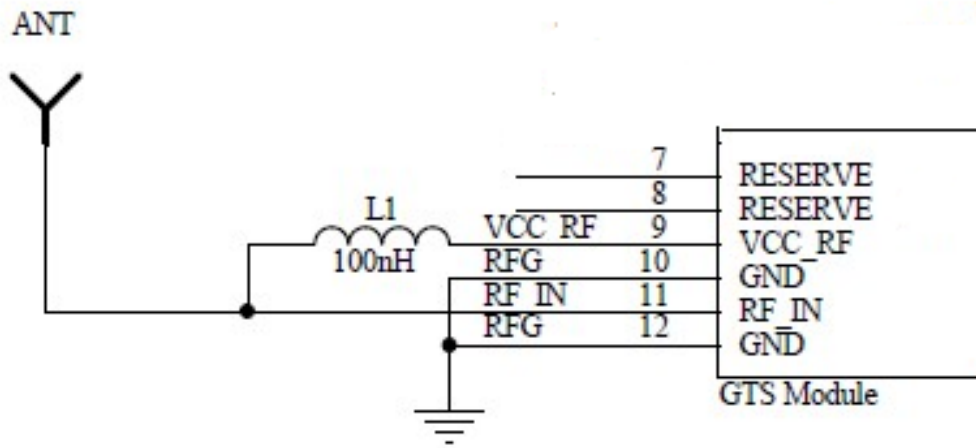

Figure 5-2 VCC\_RF supplies the power

**Note:** If the power is supplied by internal power, the supply voltage of the active antenna must be matched with the VCC. For example, if the supply voltage of the active antenna is 5V, then VCC cannot be 3.3V.

### 5.2 Passive Antenna

The following figure shows the connection of passive antenna:

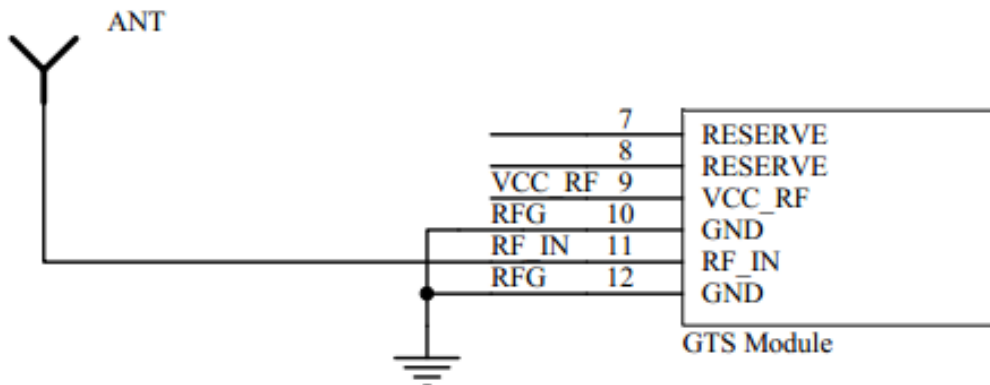

Figure 5-3 Passive Antenna Connection

## 5.3 ESD Precautions for Antennas

As for GPS receiver, antenna is a particularly sensitive area. To increase resistance to external transient voltage spikes, you can use ESD protection circuits. Like a low capacitance ESD protection diode can achieve ESD protection IEC-61000-2-4 Level 1 (The load capacitance must be less than 0.5pF, e.g. Infineon ESD0P2RF).

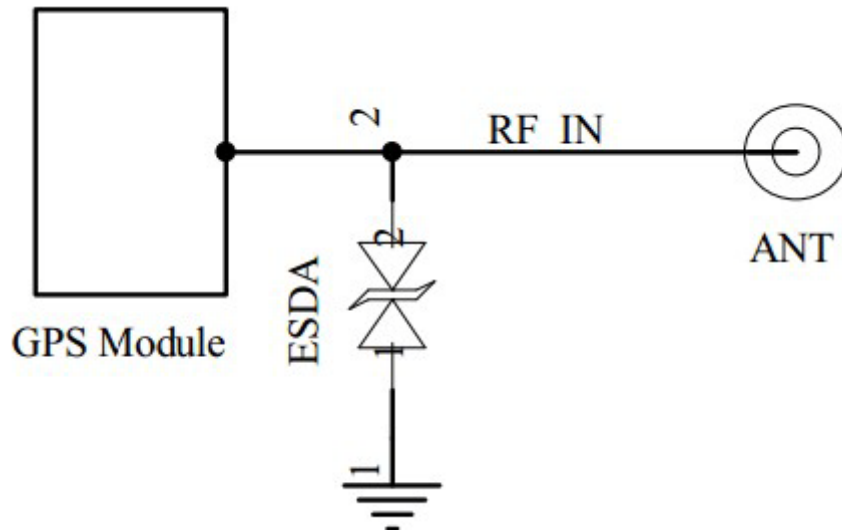

Figure 5-4 ESD Recommended Design

## X-ON Electronics

Largest Supplier of Electrical and Electronic Components

*Click to view similar products for [GPS Modules](#) category:*

*Click to view products by [Fibocom](#) manufacturer:*

Other Similar products are found below :

[A5135-H](#) [EWM-G109H01E](#) [ISM3333-C6.1](#) [S2-106ZN](#) [S2-105V4-Z185K](#) [MIKROE-4150](#) [GPS-11858](#) [4037735104327](#) [RXM-GNSS-TM-T](#)  
[EWM-G108H01E](#) [DD-14239](#) [GPS-10922](#) [GPS-12751](#) [NEO-M8P-2](#) [SIM28ML](#) [RXM-GNSS-GM-T](#) [SIM28](#) [M10578-A3](#) [M10578-A3-U2](#)  
[TEL0132](#) [POL-2G](#) [POL-3G](#) [FT-X-GPS](#) [GPS-13740](#) [PKG300060P](#) [PKG300071](#) [PKG300071P](#) [PKG900000000271T](#) [PKG900000000853P](#)  
[PKG900000000853T](#) [EZ-GPS-G](#) [A2235H](#) [RXM-GNSS-TM-B](#) [RXM-GPS-F4-T](#) [RXM-GPS-FM-B](#) [RXM-GPS-FM-T](#) [RXM-GPS-R4-T](#)  
[A1084-A](#) [A2100-A](#) [A2200-A](#) [A2235-H](#) [A5100-A](#) [28504](#) [L26ADR-S89](#) [L26T-S89](#) [L89-S90](#) [101990655](#) [113990659](#) [GPS-13670](#) [TESEO-](#)  
[LIV3F](#)