

# AKU242

## Digital Silicon MEMS Microphone

www.akustica.com

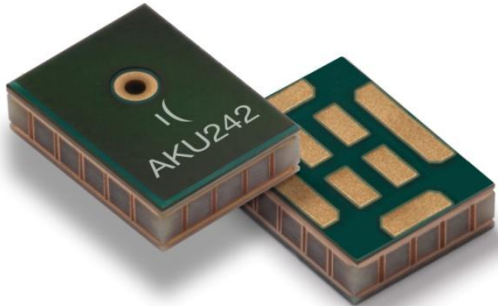

### General Description

The AKU242 is a top ported, surface mountable, digital output MEMS microphone in a space saving 4.0 x 3.0 x 1.0mm<sup>3</sup> form factor. Designed to meet Microsoft® Windows®, LYNC® & Skype® logo certifications, Intel® Ultrabook™ and Google® Chromebook™ requirements for digital microphones, the AKU242 offers excellent SNR of 63dB and tightly controlled sensitivity of -26dBFS ±1.5. Leveraging a unique packaging technology, the AKU242 provides audio engineers with the high SNR and flat frequency response of a bottom port MEMS microphone, but in a convenient top port form factor.

The AKU242 employs Pulse Density Modulation (PDM) for data output, a single-bit digital stream which enables the multiplexing of stereo microphone data onto a single wire. With a user selectable L/R channel option, the AKU242 is ideal for use in multiple microphone applications such as microphone arrays mounted on embedded camera modules in laptops or tablet PCs.

Additionally, since the output of the AKU242 is a robust digital signal, it is virtually immune to all forms of Radio Frequency Interference (RFI) and Electromagnetic Interference (EMI). For the device manufacturer, this translates to the highest degree of design flexibility and microphone placement freedom, and ultimately faster time-to-market.

### Key Features

- ▶ HD Voice Microphone
- ▶ 63dB SNR, omni-directional
- ▶ Matched sensitivity of -26dBFS ±1.5dB
- ▶ Small 4.0 x 3.0 x 1.0mm<sup>3</sup> form factor
- ▶ Super-wideband, flat frequency response
- ▶ Industry leading PSR of -73dBFS
- ▶ Robust PDM (Pulse Density Modulated) digital-output immune to RF/EM interference
- ▶ Highly-matched microphones in frequency and phase response for array applications
- ▶ Industry-standard form, fit, and function for drop-in replacement to existing module designs
- ▶ Ultra-low power sleep current
- ▶ Pb-free and RoHS compliant
- ▶ Halogen Free in accordance with IEC61249-2-21

### Target Applications

- ▶ Voice recognition applications in Ultrabooks™, Chromebooks™, mobile phones and tablet computers where digital microphones with high SNR and tightly matched sensitivity are required.
- ▶ Microphone arrays where noise cancellation and beam steering applications can be optimized by using closely-matched microphones.
- ▶ Cutting-edge, thin form factor PC/tablets and mobile accessories.

### Functional Block Diagram

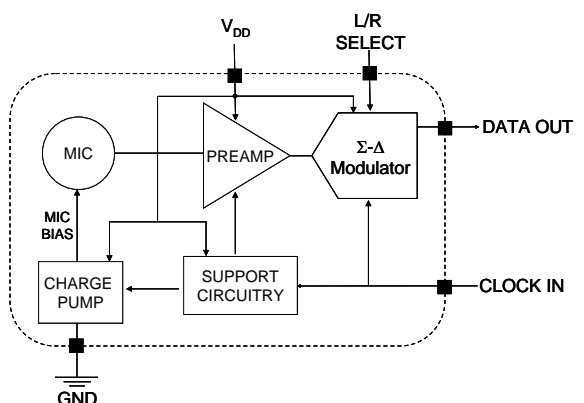

### Technical Specifications

Operating voltage	1.62V to 3.6V
Directivity	Omni-directional
SNR	63dB
Power Supply Rejection	-73dBFS
Sensitivity	-26dBFS $\pm$ 1.5
Flat Frequency Response ( $\pm$ 5dB)	50Hz to 14kHz
Current Consumption (with no load, typ.)	5 $\mu$ A (clock off) 800 $\mu$ A (clock on)
Power up Initialization	25ms (max)
Port Location	Top
Package Dimensions	4.0 x 3.0 x 1.0mm <sup>3</sup>

### Akustica Advantages

**Multiple MEMS Technologies:** With Akustica's patented single-chip CMOS MEMS technology and Bosch's world-renowned two-chip MEMS technology, Akustica is the only vendor to supply high volumes of MEMS microphones leveraging two unique technology platforms. Thus, Akustica is ideally positioned as a development partner for next generation products that meet the strict size and performance requirements of the most demanding consumer electronics device manufacturers.

**In-house Design and Manufacturing:** Utilizing patented MEMS technology and over two decades of research and development, Akustica maintains complete product knowledge by designing 100% of our MEMS microphones in-house. In addition, Akustica is the only MEMS microphone supplier to offer the security of in-house MEMS manufacturing via Bosch's state-of-the-art wafer fab in Reutlingen, Germany.

**Applications Expertise:** The performance of modern microphone systems is heavily dependent on the overall platform design, including software algorithms, mechanical layout and hardware implementation. As an innovator in the field of MEMS microphones and leveraging significant Consumer Electronics application experience, Akustica has a deep understanding of acoustic design requirements and proper analysis methods. To ensure our customers a seamless integration experience and support constrained design cycles, Akustica offers acoustic design and modeling services prior to assembly. Akustica also provides production test services, training, and test equipment to help ensure the quality of both incoming and final assembled products.

### Typical Frequency Response

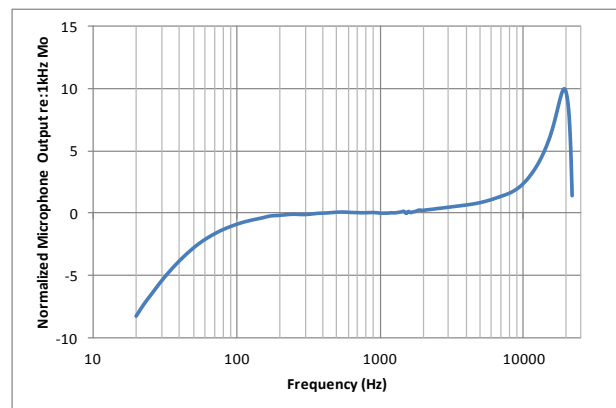

### About Akustica – Bosch Group

Akustica was founded in 2001 to develop and market a complete portfolio of digital and analog microphones using the unique and patented CMOS MEMS technology developed at Carnegie Mellon University. In 2009, Akustica was acquired by, and is now a wholly owned subsidiary of, Robert Bosch North America. As part of the Bosch Group, Akustica joins a family of companies with combined annual sales over \$70 billion and a footprint of 300,000 associates worldwide.

Bosch has been active in the field of MEMS since 1988 and is one of the pioneers in microsystem-technology. Bosch serves both the automotive and consumer electronics markets with a wide variety of MEMS products, including pressure sensors, accelerometers and gyroscopes. With more than four billion MEMS sensors shipped worldwide, Bosch is one of the world's leading suppliers of MEMS sensors.

### Ordering information

Part Number	AKU242
Description	Digital MEMS Microphone
Package	5 Pad LGA
Shipping Method	13" Reel
Standard Quantity	5,700

Please contact Akustica for further information.

### Akustica, Inc.

2835 East Carson Street, Suite 301  
Pittsburgh, PA 15203 USA  
sales: [sales@akustica.com](mailto:sales@akustica.com)  
ph: (412) 390-1730 fx: (412) 390-1737  
[www.akustica.com](http://www.akustica.com)