

PART NUMBER	MS NUMBER	SIZE REF	ØA	ØB	C	COLOR CODE	TYPE I	TYPE II
10-405996-22	MS27488-22	23/22	.040±.005	.063±.005	.469±.031	BLACK	I	
-20	MS27488-20	20	.060 <sup>+.005</sup> <sub>-.010</sub>	.090	.564±.020	RED	I	
-16	MS27488-16	16	.083±.010	.133	.564±.020	BLUE	I	
-12	MS27488-12	12	.121±.010	.171	.564±.020	YELLOW	I	
-8	MS27488-8	8	.185±.010	.315	.470±.010	RED	I	
-4	MS27488-4	4	.310±.010	.415	.470±.010	BLUE	I	
-0	MS27488-0	0	.440±.010	.605	1.000±.010	YELLOW	I	
-221	MS27488-22-1	23/22	.041 <sup>+.004</sup> <sub>-.003</sub>	.062±.004	.771±.025	BLACK		II
-201	MS27488-20-1	20	.053±.005	.085±.005	.780	RED		II
-161	MS27488-16-1	16	.074±.005	.125±.005	1.447	BLUE		II
-121	MS27488-12-1	12	.120±.005	.165±.005	1.416	YELLOW		II
-81	MS27488-8-1	8	.170±.005	.310±.005	1.164	RED		II
-41	MS27488-4-1	4	.278±.005	.409±.005	1.164	BLUE		II
-01	MS27488-0-1	0	.423 <sup>+.008</sup> <sub>-.007</sub>	.601±.005	1.046	YELLOW		II
-222	MS27488-22-2	23/22	.041 <sup>+.004</sup> <sub>-.003</sub>	.062±.004	.469±.031	BLACK		II
-202	MS27488-20-2	20	.053±.005	.085±.005	.780±.025	RED		II
-162	MS27488-16-2	16	.074±.005	.125±.005	.847	GREEN		II
-122	MS27488-12-2	12	.120±.005	.165±.005	.816	ORANGE		II
-163	MS27488-16-3	16	.074±.005	.125±.005	1.447	BLUE		II
-123	MS27488-12-3	12	.120±.005	.165±.005	1.416	YELLOW		II
-83	MS27488-8-3	8	.170±.005	.310±.005	1.164	RED		II
-43	MS27488-4-3	4	.278±.005	.409±.005	1.164	BLUE		II
-03	MS27488-0-3	0	.423 <sup>+.008</sup> <sub>-.007</sub>	.601±.005	1.046	YELLOW		II

REVISIONS			
LTR	DESCRIPTION	DATE	APPVD
H	(CL11) REDRAWN SAME SIZE ADDED P/N'S -XXI (TYPE II) ECN: 90777	1/26/2002	D.FREAR 2-4-02
J	(CL 11) CHG BLOCK ONLY CHANGE TO ALLOW USE OF -XX NUMBERS ECN: 92705	3-12-03 V.JONES	
K	(CL 11) ADDED -222 THRU -03 AND DATA, SEE ECN ECN: A6037	D.FREAR 8-11-08	

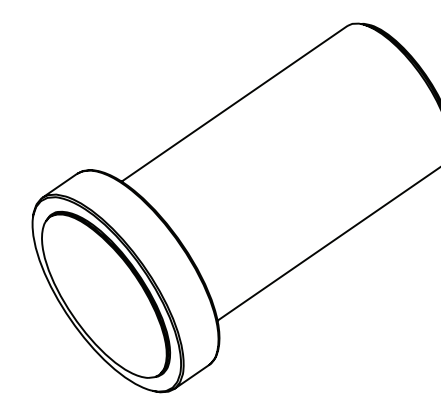

TYPE I  
SCALE 2

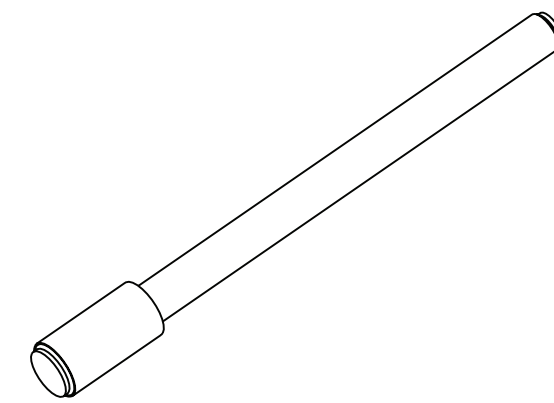

TYPE II  
SCALE 5

5. PARTS MUST BE CAPABLE OF WITHSTANDING A 90° BEND WITH NO EVIDENCE OF CRACKING.
4. INSULATION RESISTANCE SHALL BE 100 MEGOHMS MINIMUM AT 500 VDC ±2% USING FLAT PROBES ON OPPOSITE FLAT ENDS OF THE SEALING PLUG.
3. MATERIAL: FEP (ASTM-D2116)  
PFA (ASTM-D3307) OR  
PTFE (ASTM-D1710, OR PPSU (ASTM-D6394)  
RESIN. SURFACE FINISH TO BE 32/.
2. INDICATED DIAMETER MUST BE FREE OF FLASH OR SURFACE IMPERFECTIONS.

1. SPECIFIED GENERAL TOLERANCES:  
CORNERS .000-.010

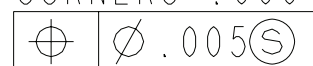

NOTES:

THE USE OF THIS DOCUMENT IS UNLIMITED. HOWEVER, DOCUMENTS REFERENCED HEREON MAY CONTAIN LIMITED RIGHTS DATA.

COMPANY ID: 9	CODED/MS/CUST: N	N/A
INTERNAL: N	LOT NO: N	
DATE CODE: N	SEE DRAW: N	N/A
STAMPING DATA		NEXT ASSEMBLY

UNLESS OTHERWISE SPECIFIED	SPECIFICATIONS	POS	QTY	PART NUMBER	DESCRIPTION	NOTE
LINEAR DIMENSIONS ARE IN INCHES TOLERANCES: .XXXX = ±.0005 .XXX = ±.010 .XX = ±.03 .X = ±.1 ANGLES = ±2° OTHER STANDARDS PER 9-3800 AND DOD-D-1000 THIRD ANGLE PROJECTION	MATERIAL SPEC.	APPROVALS		DATE	PARTS LIST	
	SEE NOTE 3	PREPARED	D. ALGER	07-Nov-01	<b>AMPHENOL CORPORATION</b> <small>SIDNEY, N.Y. 13838</small> PLUG, SEALING, GROMMET, ELECTRICAL CONNECTOR, TYPE JT-RE	
		CHECKED	D.FREAR	2-5-02		
	PROCESS SPEC.	MATERIAL	AL DAVIS	2-4-02	SCALE: 10.0 REF: 10-101033 SHEET 1 OF 2	
N/A		APPROVED	D.FREAR	1-31-02		
		APPROVED	E.SHEPLER	1-31-02	SIZE: <b>C</b> FSCM NO. <b>77820</b> DOCUMENT NO. <b>10-405996</b> REV. <b>K</b>	

FAMCODES DATA3: \* CICS: \*

10-405996

SH

1 OF 2

A

SHEET 1 OF 2

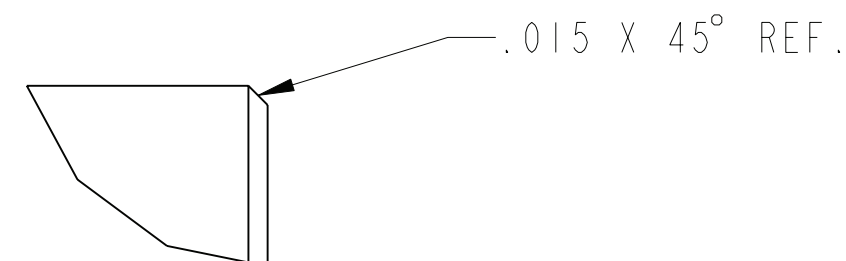
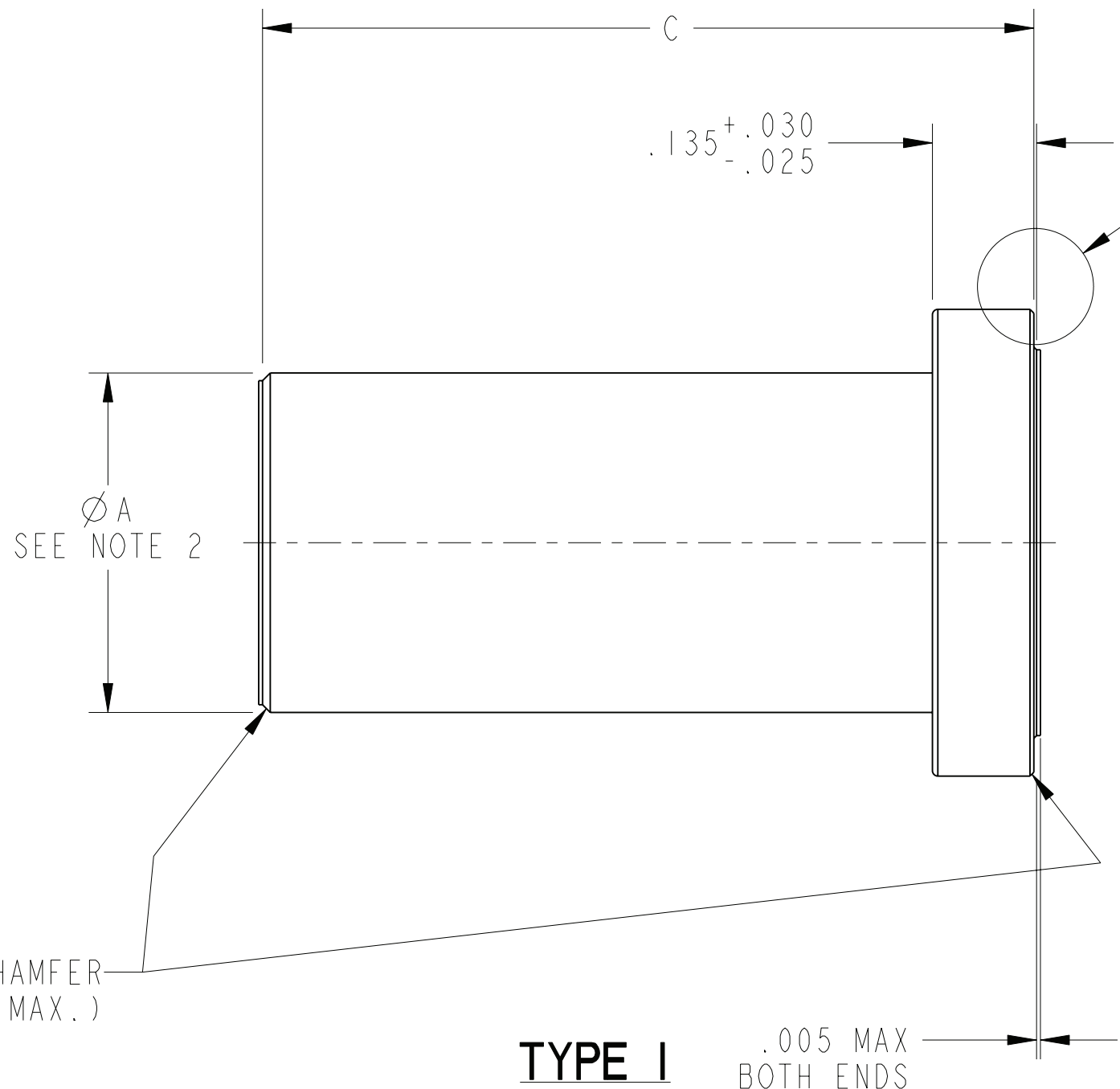
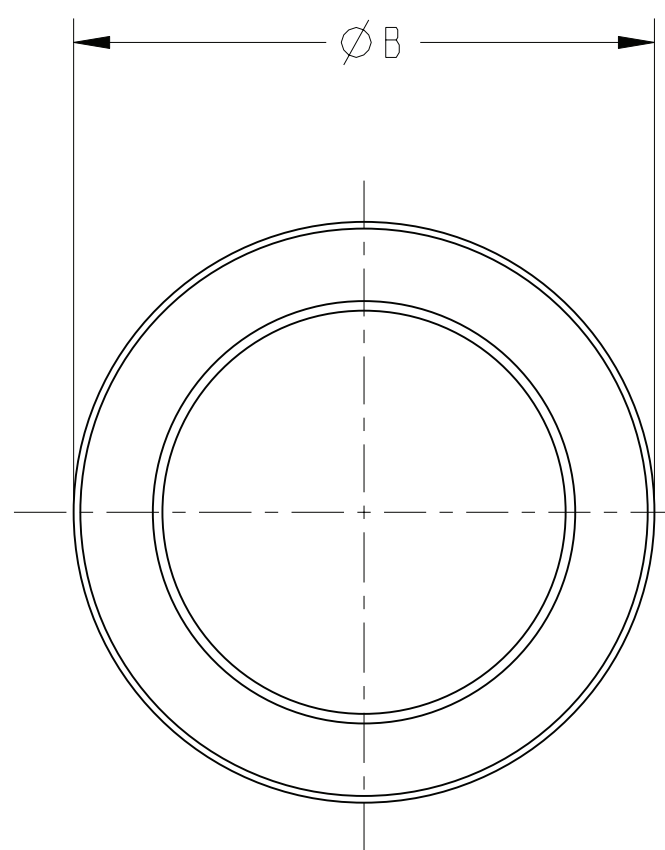

**DETAIL D**  
SCALE 20

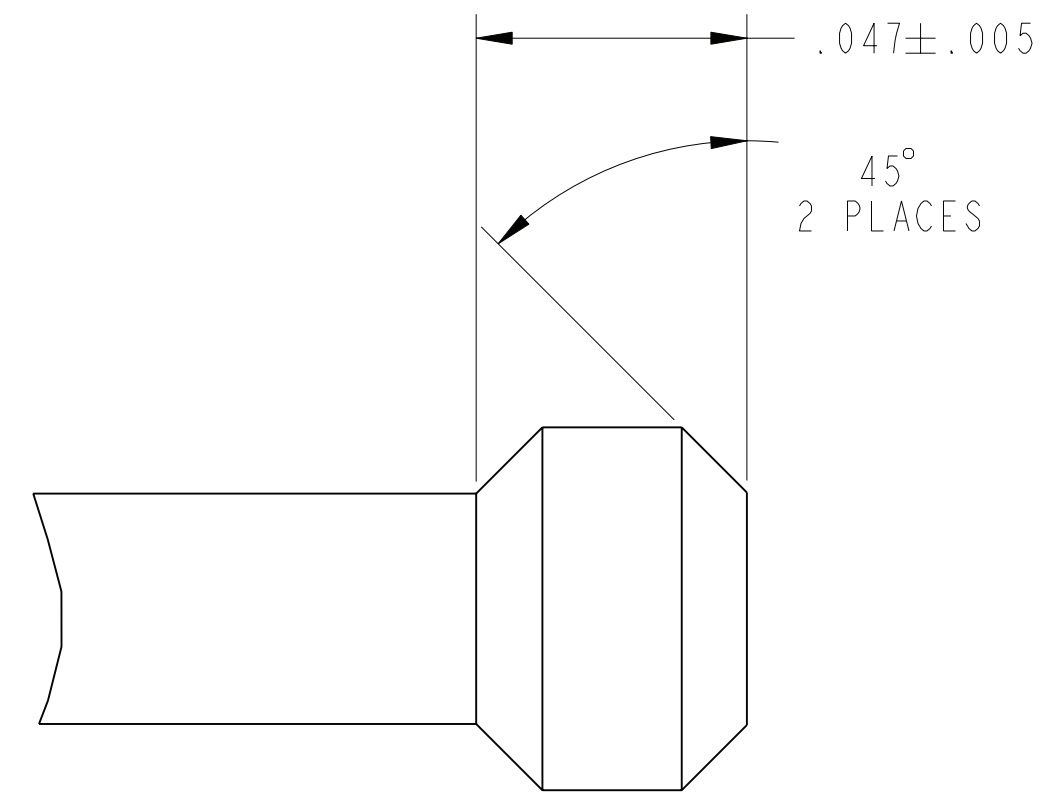

**KNOB**  
**SIZE 22 ONLY**  
**TYPE I**

**TYPE I**

$.015 \pm .005 \times 45^\circ \pm 5$  CHAMFER  
(OPTIONAL .020 R MAX.)

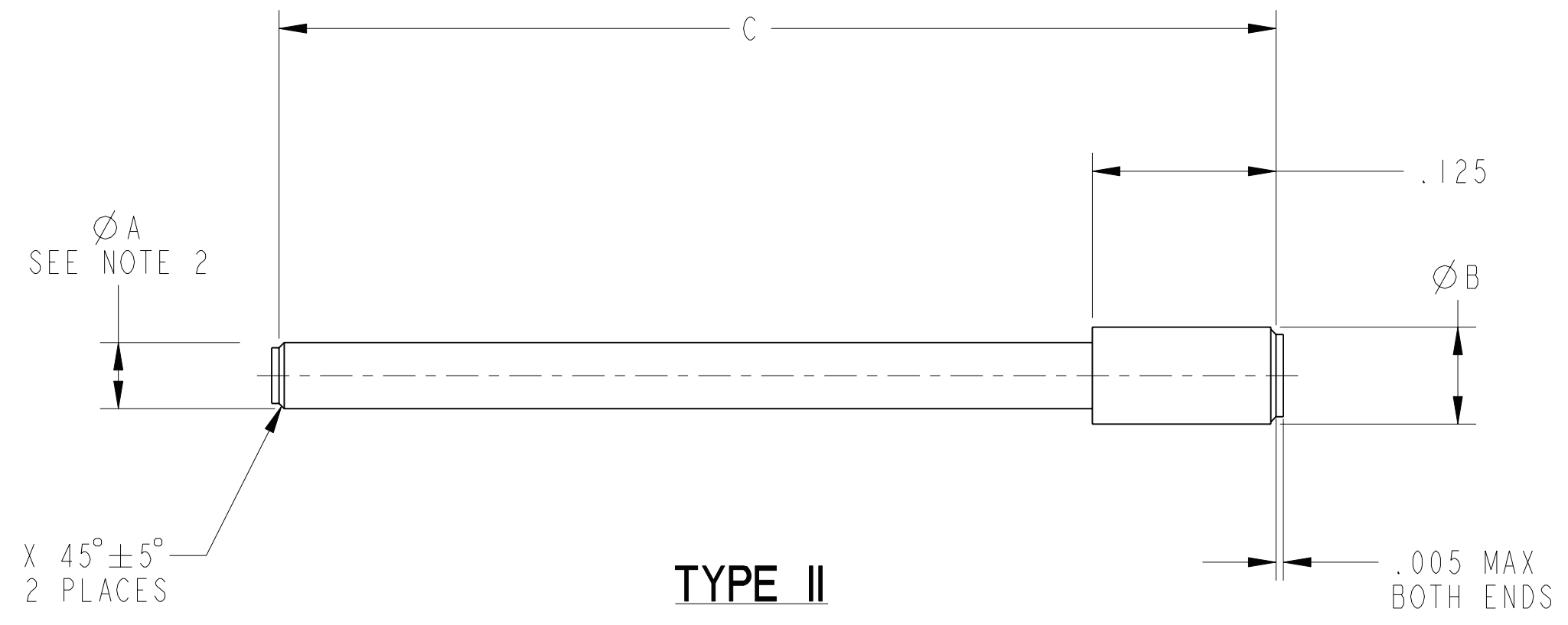

**TYPE II**

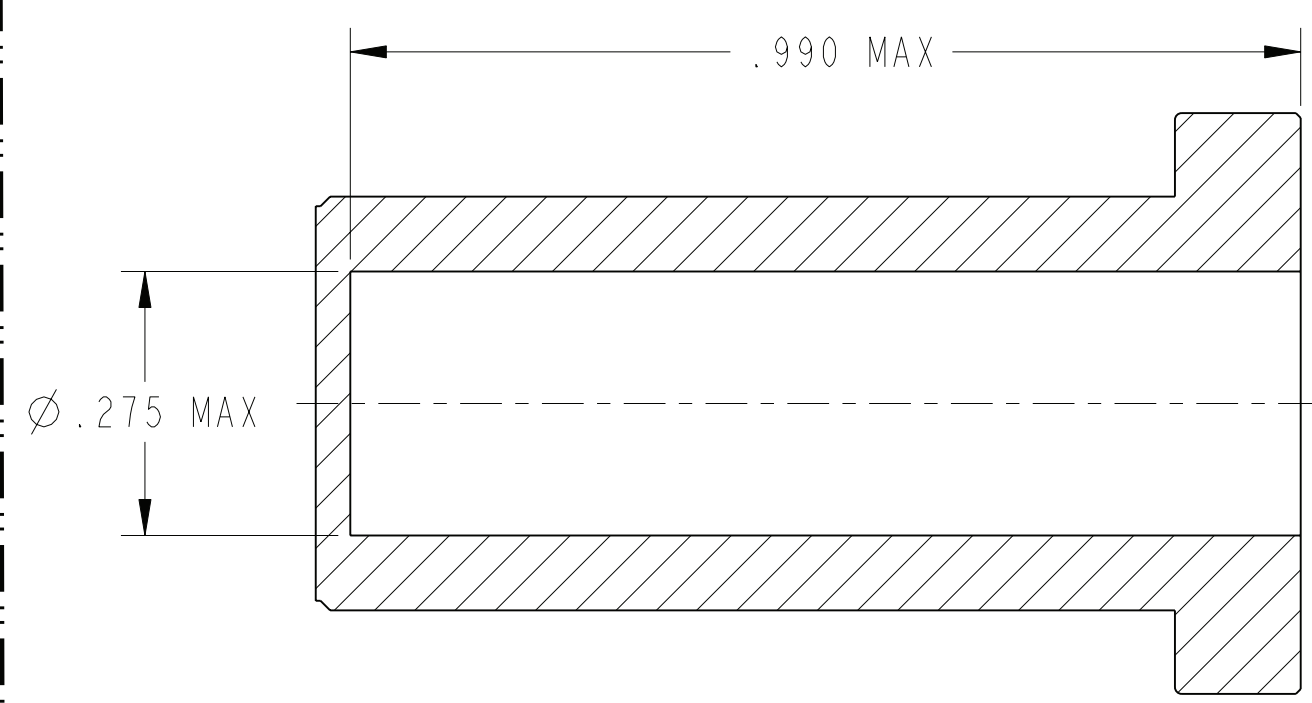

**OPTIONAL DESIGN FOR 10-405996-03**  
**(MS27488-0-3)**

THE USE OF THIS DOCUMENT IS UNLIMITED.  
HOWEVER, DOCUMENTS REFERENCED HEREON  
MAY CONTAIN LIMITED RIGHTS DATA.

SIZE <b>C</b>	FSCM NO. <b>77820</b>	DOCUMENT NO. <b>10-405996</b>	REV. <b>K</b>
SCALE: 10.0		REF: 10-101033	SHEET 2 OF 2