

PART NUMBER	DIMENSIONS				IDENT NUMBER	RELEASE	COMMENT
	A DIA +.000 -.010	B	C	D DIA			
10-150913-6	.392	.719	.234	.202	62	32508-133	Z2553-47
-8	.516	↓		.327	82		
-10	.642	.706		.444	102		
-12	.766	.719		.558	122		
-14	.892			.683	142		
-16	1.018			.808	162		
-18	1.142	↓		.909	182		
-20	1.268	.781		1.034	202		
-22	1.392	.781		1.159	222		
↓ -24	1.518	.781	↓	1.284	242	33524-601	22698-25

10-150913

REL	32508-133	WAS	DATE	D'MAN	APPD.
1	CNR	REM. 3 KNOBS EQUALLY SPACED ADD. IDENT NUMBER COLUMN, NOTE 4	3-1-57	A.NILES	
2	33524-571	ADD -24 & DATA	6-9-58	A.NILES	
3	33524-601	RELEASE -24	8-8-58	FEN	
4	34281-1	REM FLASH PERMISSIBLE (1 PLACE)	8-13-58	Lambrecht	
5	36878-2	ADD .125 MIN, NOTE 5.	7-1-60	RICKS	
6	38330-1	ADD. NOTE 6	6-6-61	DYKEMAN	
AI	44781-1	(MFG); ADD. NOTE 7	5-17-65	Lambrecht	
B	20079	(CL D) WAS .719 (-10)	1/19/88	Melligot	Nesbit
C	20603	(CL D) WAS .031±.010 (.031+.015-.010)	7-21-88	Melligot	Nesbit

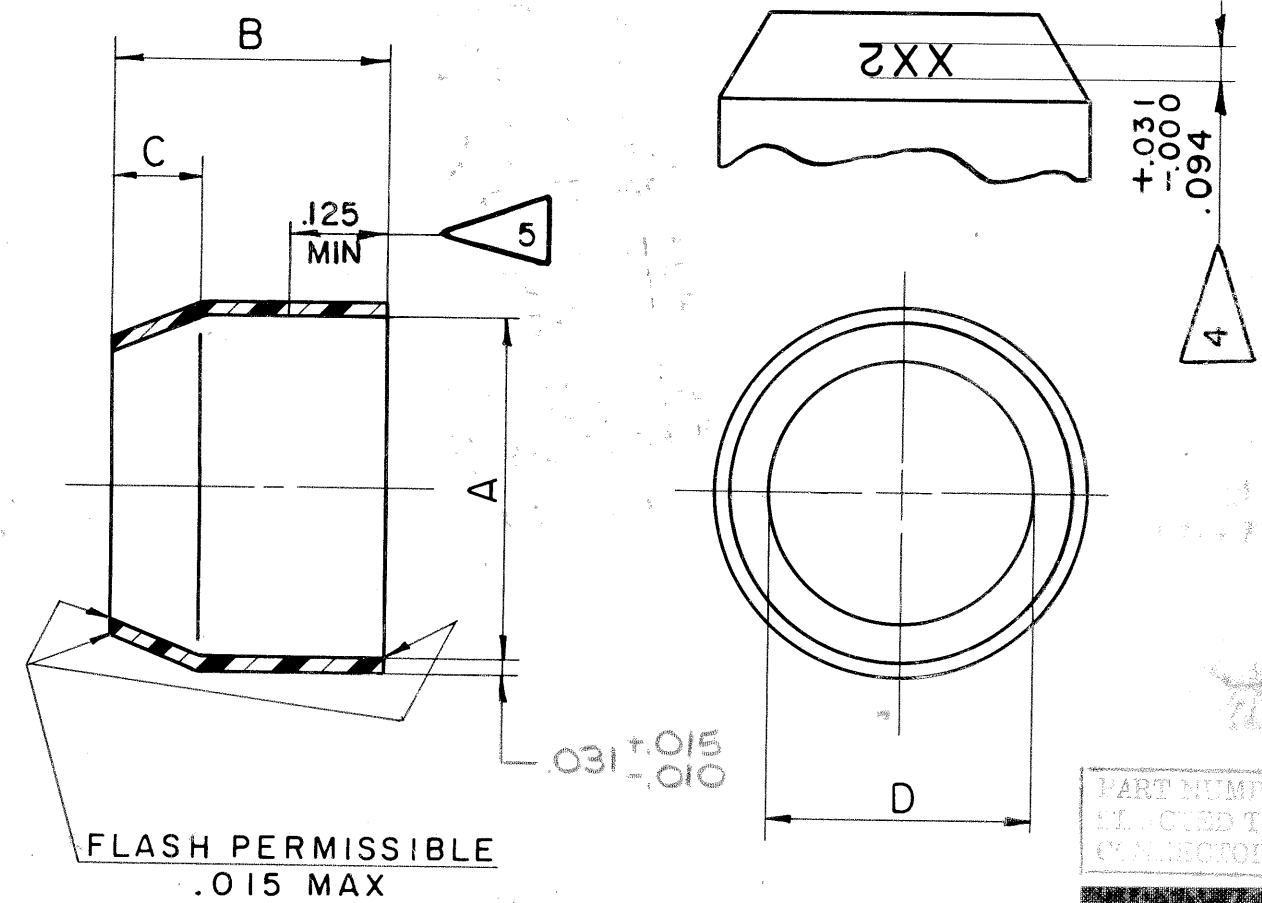

PART NUMBER USAGE DE-
SELECTED TO ELECTRIC
CONNECTOR DESIGN GROUP

NOTE: REF SYMBOL <

7. PARTS SHALL BE CLEANED AFTER MOLDING TO REMOVE FOREIGN MATERIAL.
6. ANNEAL PARTS IMMEDIATELY AFTER MOLDING AND MOISTURE CONDITION TO APPROXIMATELY 2.5 PER CENT.
5. TOLERANCE OF A DIAMETER TO BE APPLICABLE FOR INDICATED LENGTH.
4. IDENTIFICATION NUMBER TO BE LOCATED IN RELATIVE POSITION SHOWN ON INSIDE OF END BELL. NUMBERS TO BE RAISED .006-.010.
3. PARTS TO BE TRANSPARENT TO TRANSLUCENT.
2. E. I. DUPONT DE NEMOURS & CO, INC ZYTEL 101.
1. ENGINEERING SOURCE APPROVAL REQUIRED.

MATERIAL SPEC. NYLON SEE NOTES 1 & 2	PROCESS SPEC.	SCINTILLA MAGNETO DIVISION BENDIX AVIATION CORPORATION SIDNEY, N. Y., U.S.A.				TOLERANCES UNLESS OTHERWISE SPECIFIED FRACTIONS ± 1/32 DECIMALS ± .010 ANGLES ± 2° CONCENTRICITY .015 FIR. BREAK SHARP EDGES .010-.030 SQUARENESS .010 PER INCH OF LENGTH MACHINED SURFACES MUST BE FLAT AND PARALLEL WITHIN THE TOLERANCE OF THE APPLICABLE DIMENSION AND SMOOTH WITHIN 200 MICRO-INCHES RMS.	
HEAT TREAT SPEC.	FINISH SPEC.	NAME END BELL, POTTING, ELECTRICAL CONNECTOR, TYPE BT ()				NEXT ASSEMBLY 72-105606 THRU 72-105650 72-127006 THRU 72-127050	WEIGHT - LBS.
TOOL ACC.	COM. R: ABOVE	D'MAN VIMISLIK	CHECKER Rudak	MAT. CP	ST'DS Whit	CH. D'MAN Dunne	APPROVED Whit
		1-29-57	3-5-57	8-4-57	3-6-57	3-8-57	3-8-57
					NONE	REF. 10-117913	10-150913