

NOTES:

- MATERIALS OF CONSTRUCTION:  
SHELL, HOUSING, BODY, RETAINER RING, LOCK RING,  
WASHER & COVER = BRASS, NICKEL PLATED .0001 MIN.  
CONTACT PIN = BRASS GOLD PLATED.  
CONTACT PIN = PHOSPHOR BRONZE, GOLD PLTED.  
SPRING = COPPER, NICKEL PLATED .00002 MIN.  
INSULATORS = TEFLON  
GASKET = RUBBER, COLOR RED.
- PACKAGE CONNECTOR IN BAG.
- DO NOT SCALE THIS DRAWING.
- UNLESS OTHERWISE SPECIFIED, ALL DIMENSIONS ARE AFTER PLATING.

31-9-75

REVISIONS

DRAWING NO.	REV	DESCRIPTION	DATE	ECO	APPR
THIRD ANGLE PROJ.	--	RELEASE TO MFG.			
	B	SEE SHEET 1	11/11/98	42703	CPM/

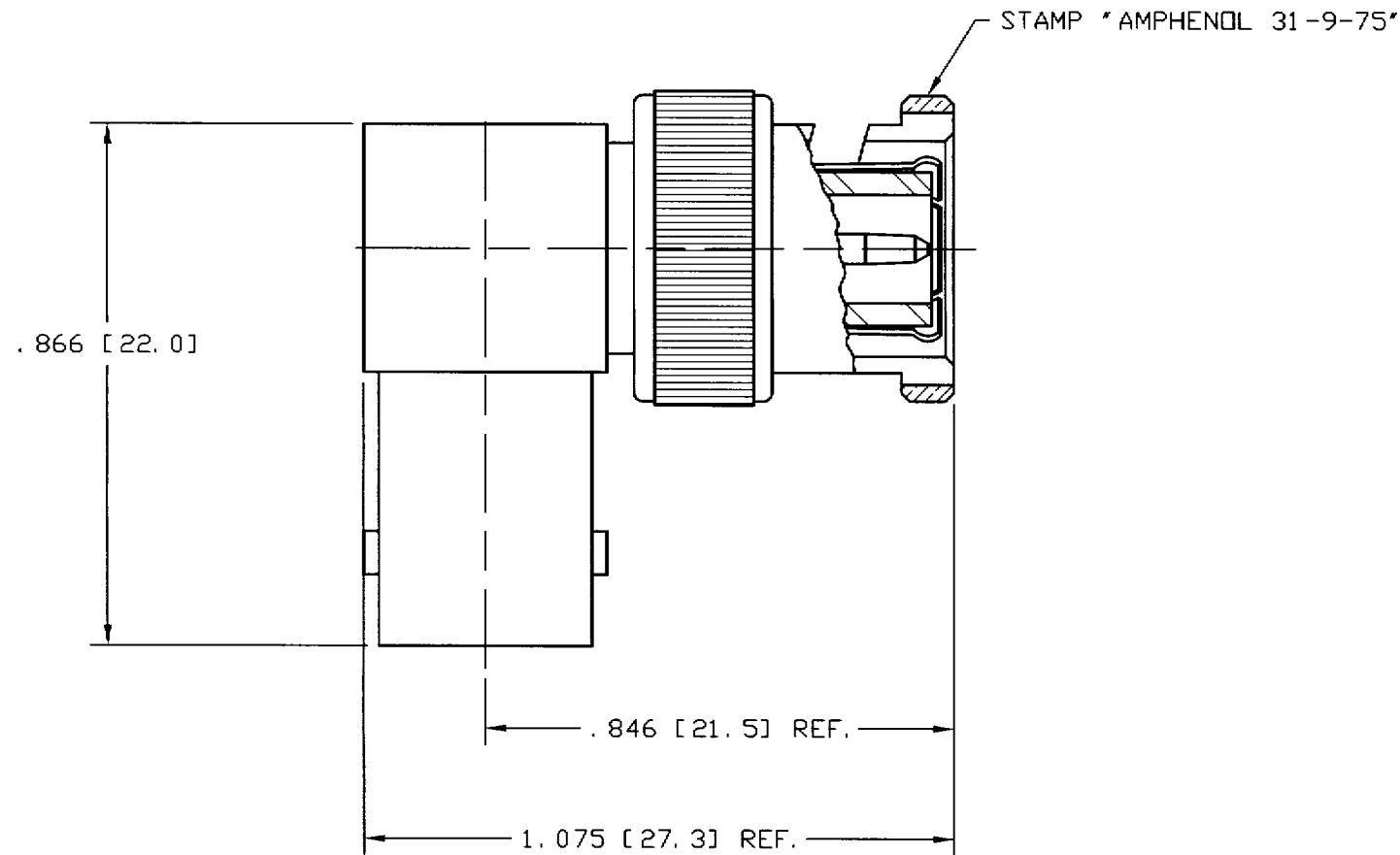

CUSTOMER OUTLINE DRAWING

UNLESS OTHERWISE SPECIFIED, DIMENSIONS ARE IN INCHES AND TOLERANCES ARE: 2 PLACE DECIMAL ±.015 (0,381 mm) 3 PLACE DECIMAL ±.005 (0,127 mm) ANGLES ± 1°	MATERIAL	DRAWN C. McGRATH	DATE 10/28/98	TITLE BNC ADAPTOR 75 OHM	<b>Amphenol</b> Amphenol Corporation RF/Microwave Operations Danbury, Conn. U.S.A. 06810	
	REFERENCE	ENGINEER T. AUBIN	DATE 10/28/98	APPROVED 		SCALE: 3:1 SHEET 2 OF 2
NOTICE - These drawings, specifications, or other data (1) are, and remain the property of Amphenol Corp. (2) must be returned upon request; and (3) are confidential and not to be disclosed to any person other than those to whom they are given by Amphenol Corp. The furnishing of these drawings, specifications, or other data by Amphenol Corp., or to any other person to anyone for any purpose is not to be regarded by implication or otherwise in any manner licensing, granting rights or permitting such holder or any other person to manufacture, use or sell any product, process or design, patented or otherwise, that may in any way be related to or disclosed by said drawings, specifications, or other data.		CAD FILE H:\DEPT611\BNC\031\ASSY\9-75SH2	CODE ID 74868	DWG SIZE B	DRAWING NO. 31-9-75	ISSUE B