



**Application Note: UHF RFID Femto Reader**

**HW-Description**

**AS3993**

**UHF RFID Single Chip Reader EPC  
Class1 Gen2 Compatible**

---

## Table of Contents

1. Introduction .....	2
2. Key Features .....	3
3. Applications .....	4
4. Reader System Overview.....	5
5 Interfaces.....	7
5.1 USB.....	7
5.2 UART Interface.....	8
5.3 MCU Debug Interface .....	9
5.4 SPI Interface .....	10
5 Reader System Description.....	11
5.1 RF Tracks – Impedance Calculation .....	11
5.2 Reader Part – PCB Stackup .....	11
5.3 RF Path.....	12
5.4 Power Supply .....	12
5.5 Schematics.....	13
Copyright .....	17
Disclaimer .....	17
Figure 1 - Reader Top .....	5
Figure 2 – Reader Bottom .....	6
Figure 3 - USB Interface.....	7
Figure 4 - UART Interface Connections .....	8
Figure 5 - MCU Debug Interface .....	9
Figure 6 - SPI Interface Connections .....	10
Figure 18 - OAD Pads .....	10
Figure 7 - RF Tracks - Impedance Calculation (dimensions in mil) .....	11
Figure 8 - RF Part - PCB Stackup .....	11
Figure 9 - Reader System Components.....	13
Figure 10 - Schematic Reader Section .....	14
Figure 11 - Schematic RF Section .....	14
Figure 12 – Schematic Tuning Circuit .....	15
Figure 13 - Schematic Controller Section.....	15
Figure 14 - Schematic Connector Section.....	16
Figure 15 - Schematic Power Supply Section.....	16



## 1. Introduction

The Femto Reader is a small form factor and low costs EPC Class 1 Gen 2 UHF RFID demonstration reader system. Leveraging ams' UHF RFID AS3993, provides close to the industry's lowest BOM cost, best in class power consumption with the least amount of complexity.

Second only to ams Femto design the low reader BOM enables UHF RFID markets that have previously been out of reach due to cost restraints. With regards to overall cost vs. performance the FERMI UHF RFID demo reader is unmatched in the industry.

By using the internal PA delivering up to 20 dBm, it is ideally suited for cost and form factor constraint applications.

The Femto demo reader features an antenna tuning circuit to re-tune the resonance frequency of the antenna in case a de-tuning occurs. In addition the Femto reader features an antenna switch to allow UHF RFID operation through an external antenna or the onboard chip antenna<sup>1</sup>.

The Femto reader is designed as such that it can be easily connected to an external host MCU via SPI leaving the onboard MCU idle. The high level of integration found on the AS3993 UHF RFID AS3993 allows for minimal code loading and quick implementation.

The designs come with free, fully portable code and all Gerber data and schematics. This allows for a quick, trouble free design in.

---

<sup>1</sup> Not populated for Femto Version 1.x



## 2. Key Features

- Interface
  - Between the Controller and Host Computer: USB (optional UART)
  - SPI between an off-board controller and the AS3993 via a low cost pin header connection
  - SMA (Female) connector for external antenna
- Special
  - Antenna tuning circuit
  - Antenna switch
  - Enabled for onboard antenna
- 5V power supply from USB.
- GUI
  - Adjust Output Power
  - Adjust Receive – Sensitivity
  - Adapt to different frequency schemes (FCC ETSI)
  - Change Gen2 specific parameters like BLF, Coding, Anti-Collision Slots, ...
  - Diagnostic Features: RSSI Measurement, Reflected Power Measurement
  - Support for sending AS3993 related direct commands
  - Advanced Tag Manipulations: R/W to different memory banks, define passwords
  - Associate tags with other applications like media player
  - View and easily manipulate register settings with advance tool tip text.
  - Antenna selection
  - Tuning circuit control
- Fully Gen 2 compliant, ISO 18000-6b & 6c
- Differential TX chip-output configuration
- Differential RX chip-input configuration
- Internal power amplifier with a maximum output power of 20 dBm



- Low cost MCU: Microchip (PIC24FJ64GB004)
- Indicator LEDs

### 3. Applications

Typical applications for the FERMI demo reader include:

- Embedded Consumer Applications
- Mobile Applications (Low Power Handheld, PDA's, Smart Phones)
- Embedded Industrial Applications
- Gaming
- Desk top readers
- Low/Mid powered modules



## 4. Reader System Overview

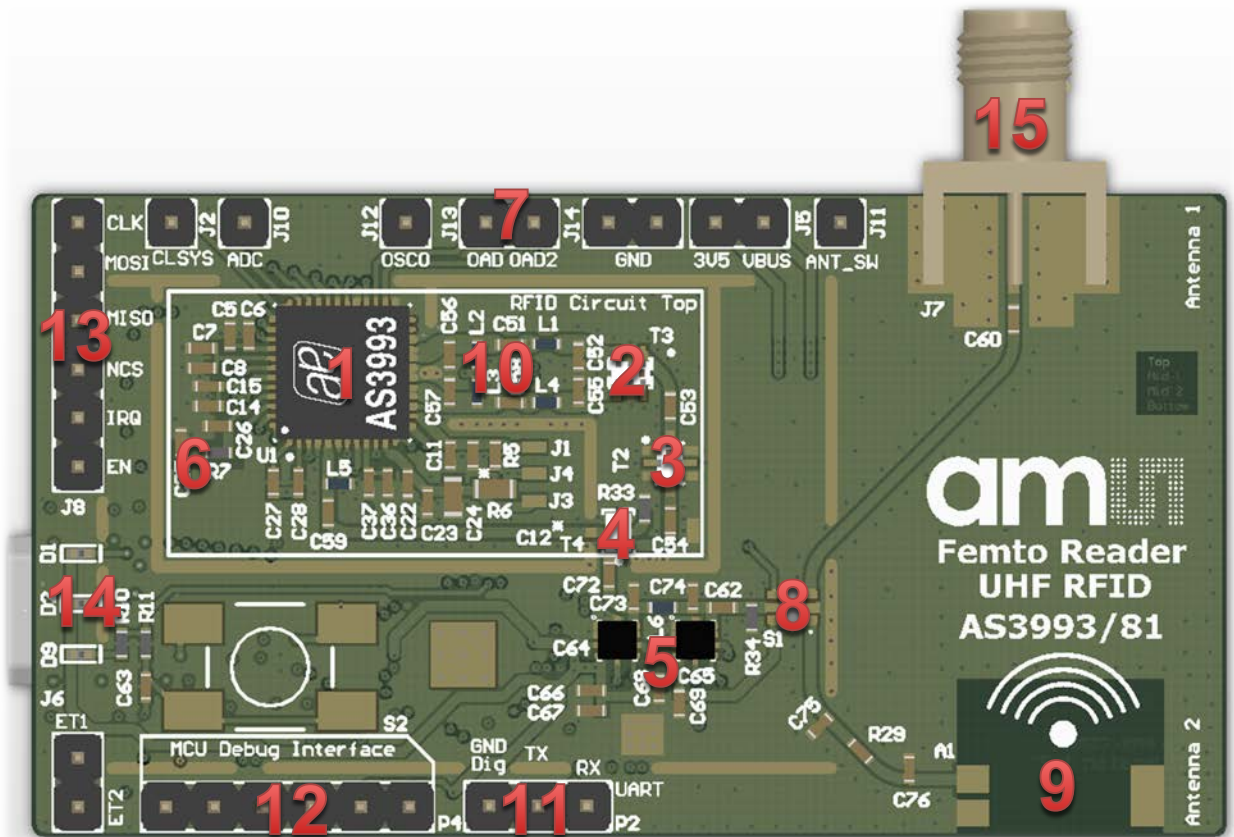

Figure 1 - Reader Top

1. AS3993 UHF RFID AS3993 (ams)
2. Balun 2:1 (Johanson Technology)
3. Low pass filter
4. Directional coupler / combination (Johanson Technology)
5. Antenna tuning circuit
6. Loop Filter
7. OAD pins for debugging purposes
8. Antenna Switch
9. Onboard antenna (not populated)
10. Internal PA matching Circuit
11. UART interface
12. Debug interface

- 13. SPI pin header for external MCU
- 14. Indicator LEDs
- 15. SMA (female) connector for external antenna

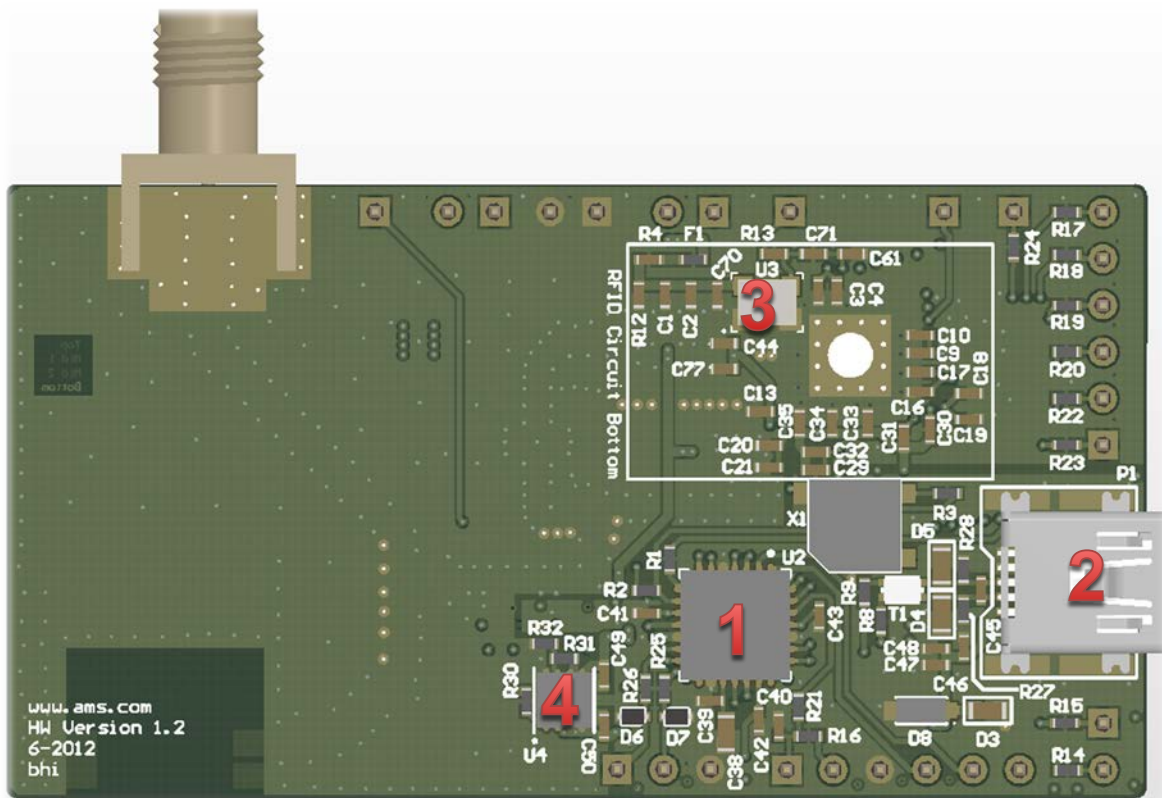
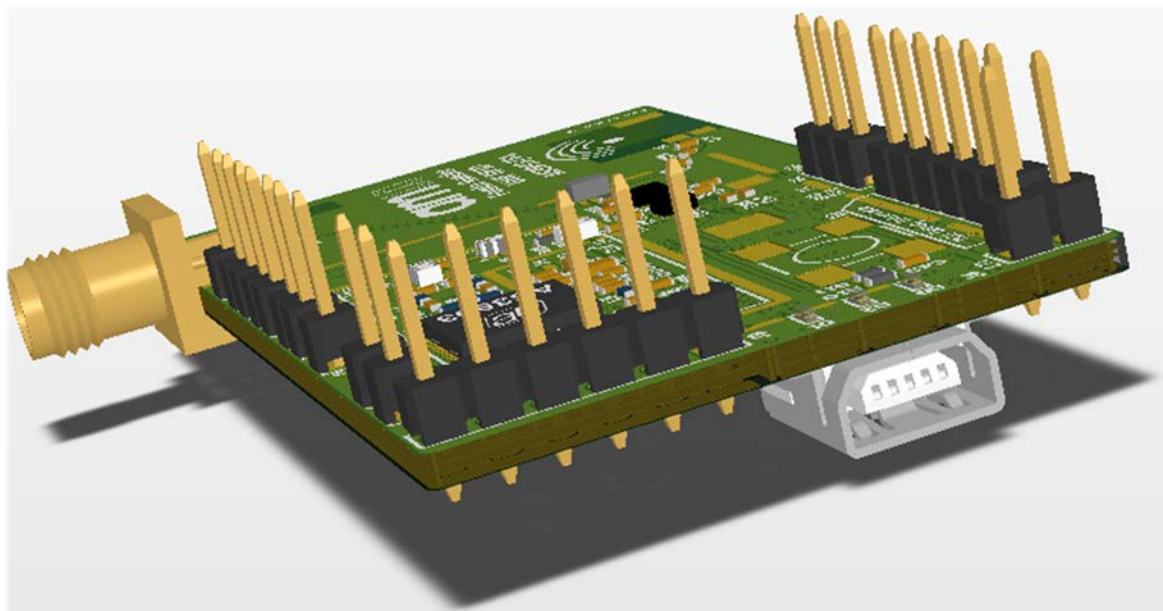

Figure 2 – Reader Bottom

- 1. MCU C8051F340 (Silabs)
- 2. USB connector
- 3. TCXO
- 4. LDO (5 V → 3.5 V)

## 5 Interfaces

### 5.1 USB



*Figure 3 - USB Interface*

The USB is used to communicate to the host computer and to supply the reader system. The 5V USB voltage is regulated down to 3.5 V.



## 5.2 UART Interface

In order to establish a connection to the host computer via UART it is recommend using an USB TTL serial cable with 3.3 Volt (FTDI TTL-232R-3V3-WE). The UART connection is established through P2. The 5 Volt power supply should be provided via the USB connector or J2.

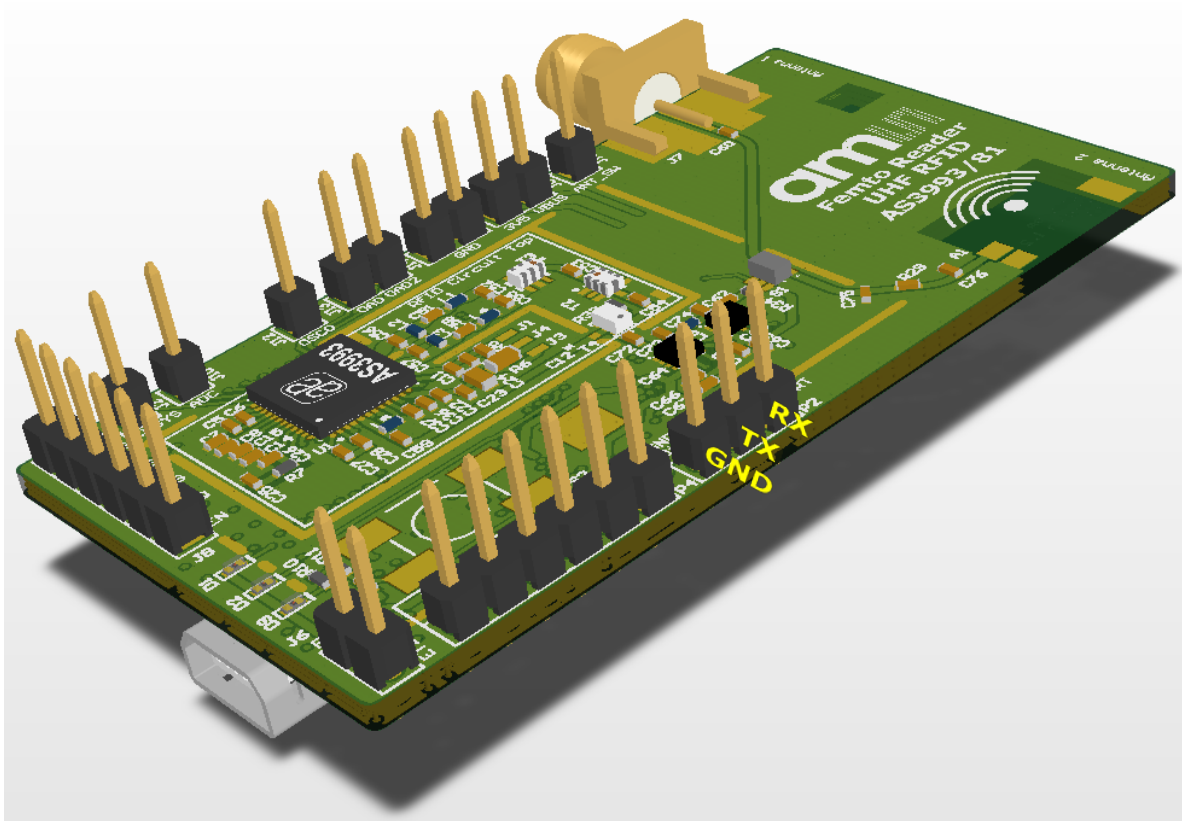

Figure 4 - UART Interface Connections

Note: Once the firmware is programmed to communicate via UART the USB connecting is required to reprogram the FW.

### 5.3 MCU Debug Interface

To load the bootloader to the reader the debug interface connected to P4 should be used.

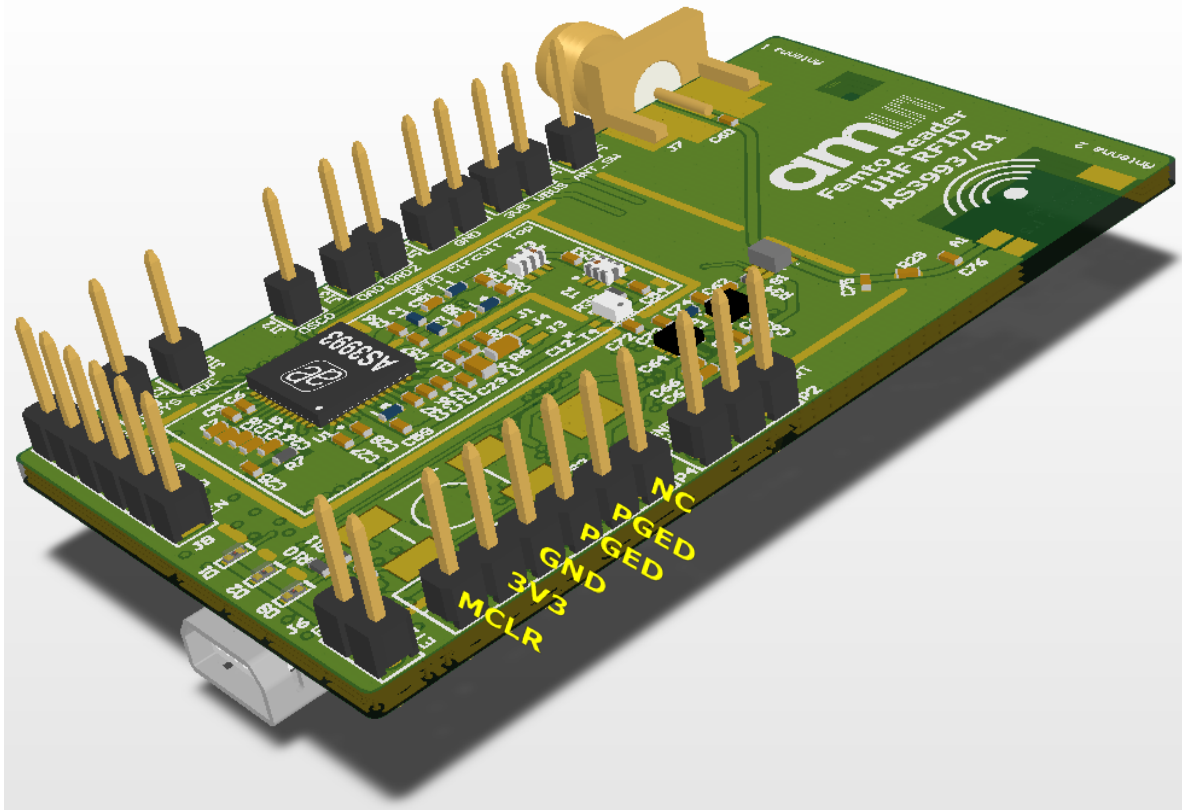

Figure 5 - MCU Debug Interface

### 5.4 SPI Interface

All needed digital control lines and the SPI interface pins are connected to the pin header J8. To be able to connect to an external MCU the 0 ohm resistors R17 – R23 should be removed. The SPI enable lines for the DTC are located on J6 and are connected to the onboard controller via R14 and R15.

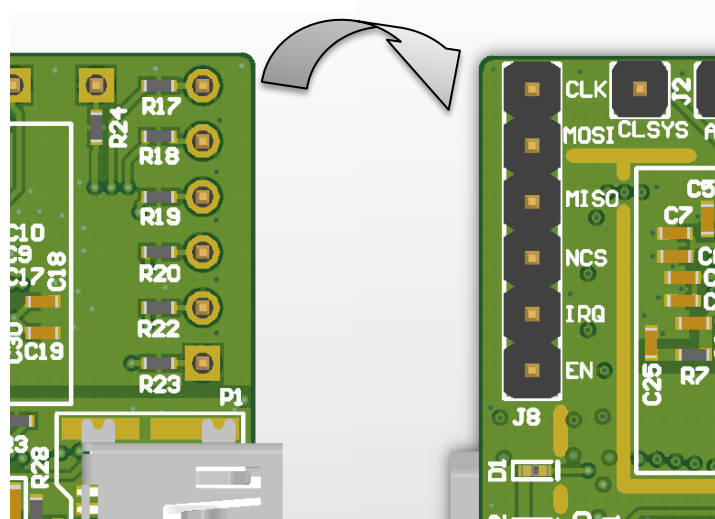

Figure 6 - SPI Interface Connections

### 5.5 OAD Pins

Jumper J13 is connected to the OAD pins of the AS3993 which can be used to output analog/digital RX subcarrier signals or TX / RX based band signals.

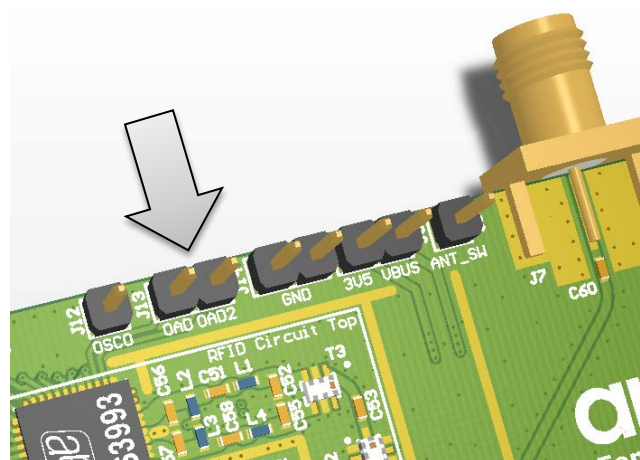

Figure 7 - OAD Pads

## 5 Reader System Description

The top side of the reader PCB contains all RF and UHF RFID relevant components. On the bottom side the MCU and the power supply generation is placed. The PCB has 4 layers with  $\epsilon_r = 4.5$  dielectric constant.

### 5.1 RF Tracks – Impedance Calculation

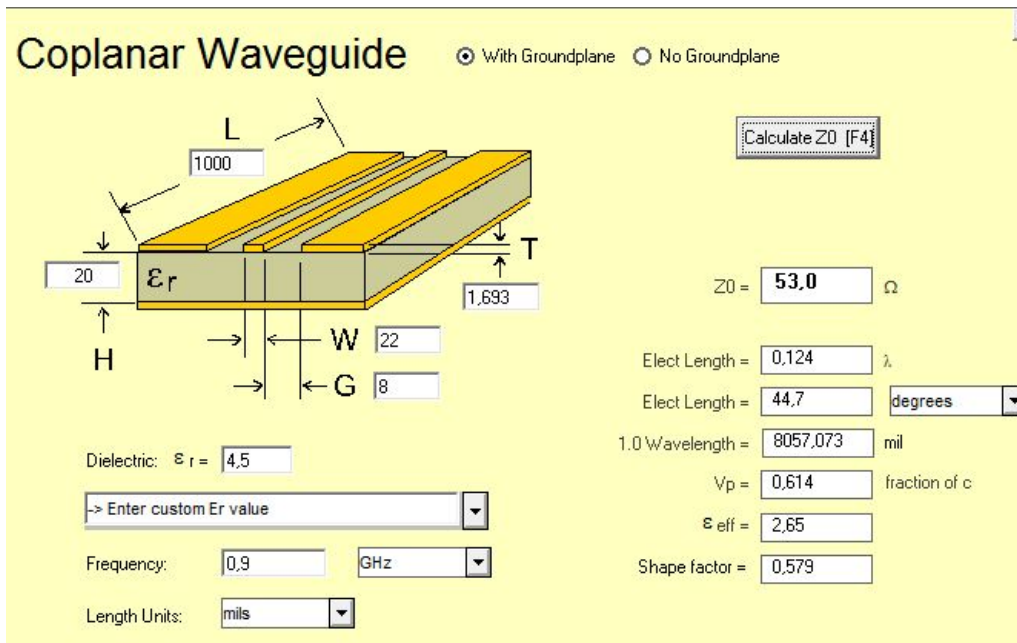

Figure 8 - RF Tracks - Impedance Calculation (dimensions in mil)

### 5.2 Reader Part – PCB Stackup

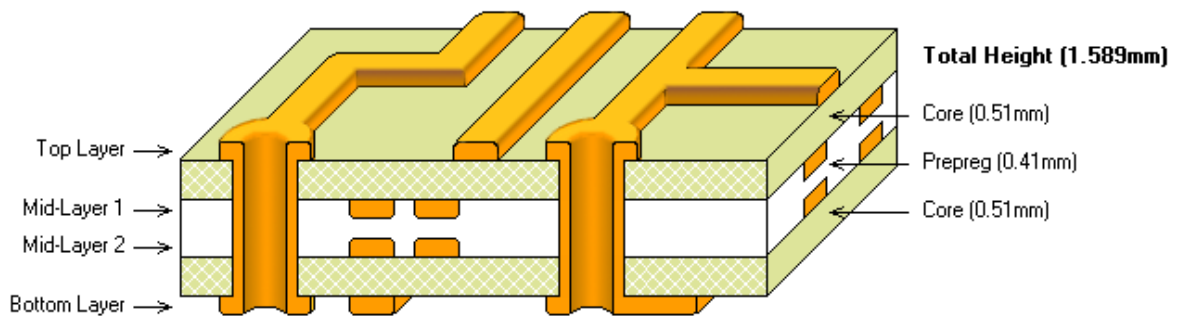

Figure 9 - RF Part - PCB Stackup



### 5.3 RF Path

The RF signal is output at the AS3993 pins 16, 17 and 20, 21. Since the output impedance of the internal PA is not 50 ohm a load line matching network is required to deliver an maximum of power. Through the matching circuit (L2, L3) the output driver stage of the internal Pa is supplied by VDD\_PA. The RF signal after the matching circuit is still differential therefore a 1:1 Balun is used to transform the impedance to 50 ohm single-ended. The low pass filter (T2) is needed to attenuate higher order harmonics of the carrier frequency. The low pass filter should have 30 dB attenuation at the third order harmonic. After the low pass filter the RF signal is routed to the directional coupler which should provide a directivity of ~22 dB. The input coupled port is terminated by a 51 ohm resistor. The direct port is connected to the tuning circuit towards the antenna and the isolated port is connected to the single ended receiver input pin of the AS3993. The tuning circuit is essentially a PI structure consisting of two shunt capacitors and a series inductor. To enable a tuning of this circuit the shunt capacitors are extended by digital tunable capacitors (DTC<sup>2</sup>). The capacitance change is controlled by the MCU via the SPI interface. After the tuning circuit the RF signal can be switched to the SMA connector in case an external antenna is connected or to the onboard antenna<sup>3</sup>. Please note the onboard antenna is not populated.

The returning tag signal again travels through the antenna switch, the tuning circuit and is coupled (10 dB) to the receive pin of the AS3993. C59 and L5 provide a DC path to ground which is required by the receiver inside the AS3993.

### 5.4 Power Supply

The Femto reader is supplied by 5V which is taped from the USB connector. 5 Volts can also be supplied through pin 2 of pin header J5. Since the AS3993 is designed for mobile and battery powered devices the 5 Volts need to be reduced. This is done by an LDO (U4<sup>4</sup>). The LDO has an adjustable output voltage which is set by a resistor divider (R31, R32) at the LDO output. The output voltage is set to 3.5 Volts and supplies the AS3993, the MCU, the DTCs and the TCXO. The used LDO can deliver 1 A and has a low drop out voltage of only 140 mV @ 1 A.

---

<sup>2</sup> DTC: PE64904 by Peregrine Semiconductor

<sup>3</sup> 0868AT54B0020 by Johansson Technology

<sup>4</sup> AS1364 by AMS

### 5.5 Schematics

#### System Components

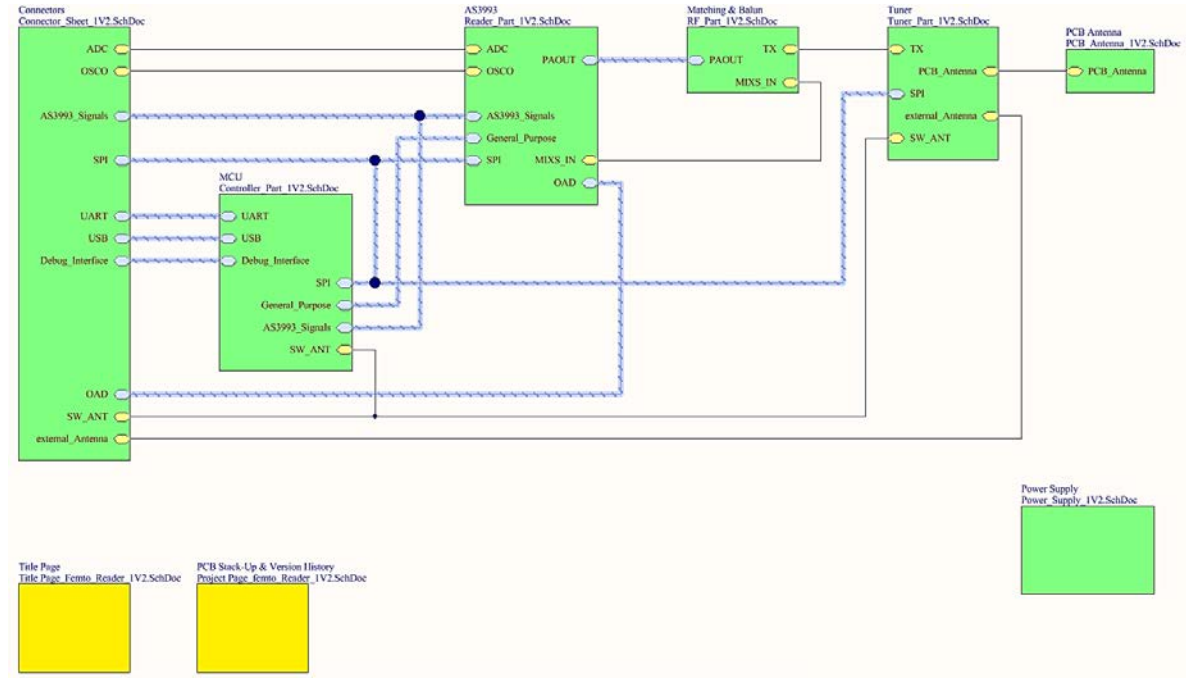

Figure 10 - Reader System Components

Reader Section:

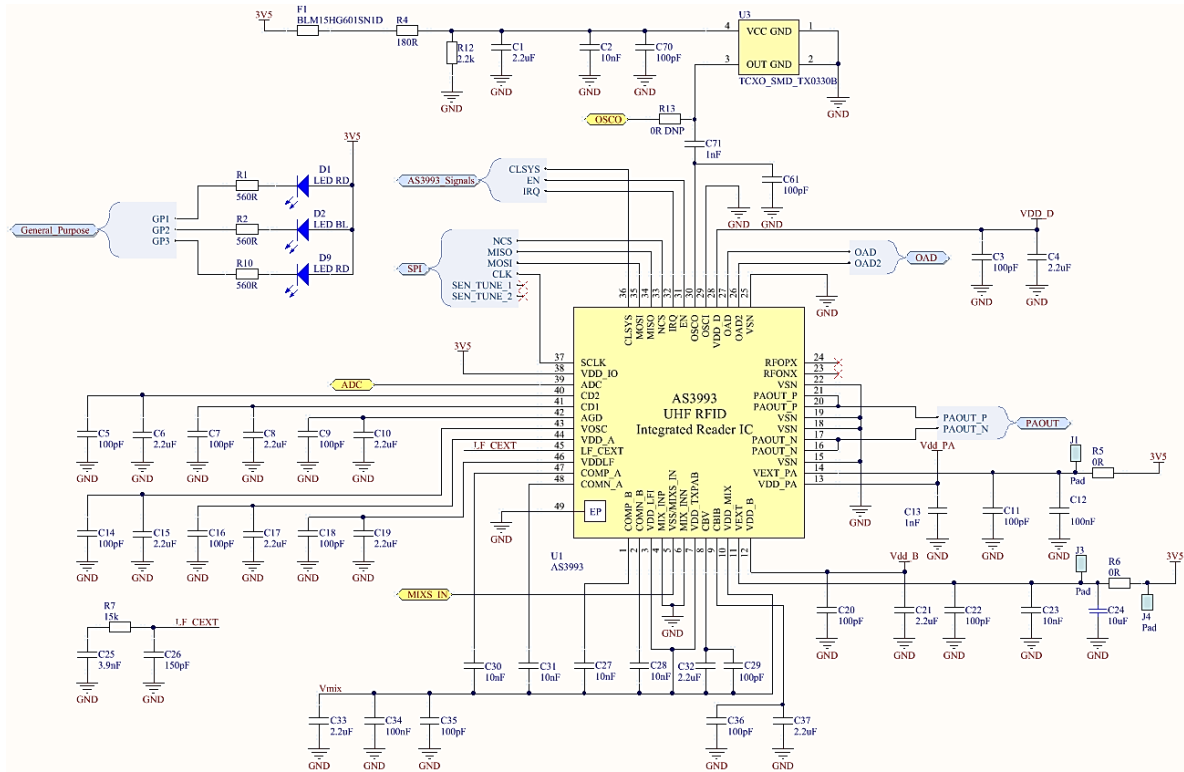

Figure 11 - Schematic Reader Section

RF Section

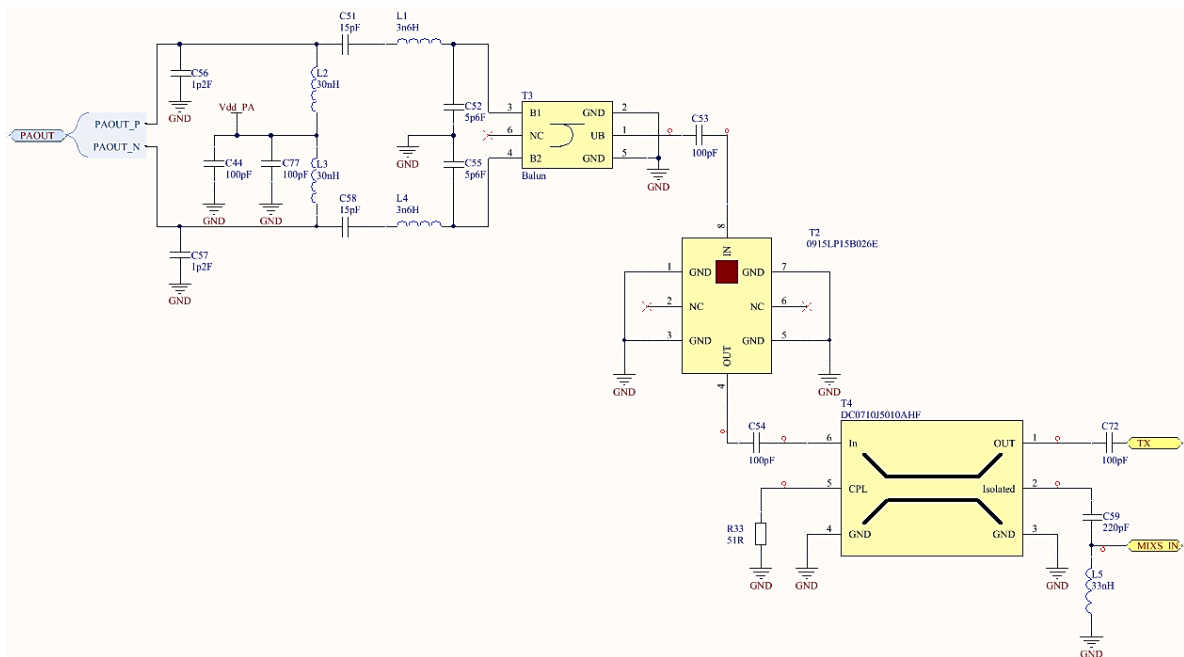

Figure 12 - Schematic RF Section

Tuning Circuit :

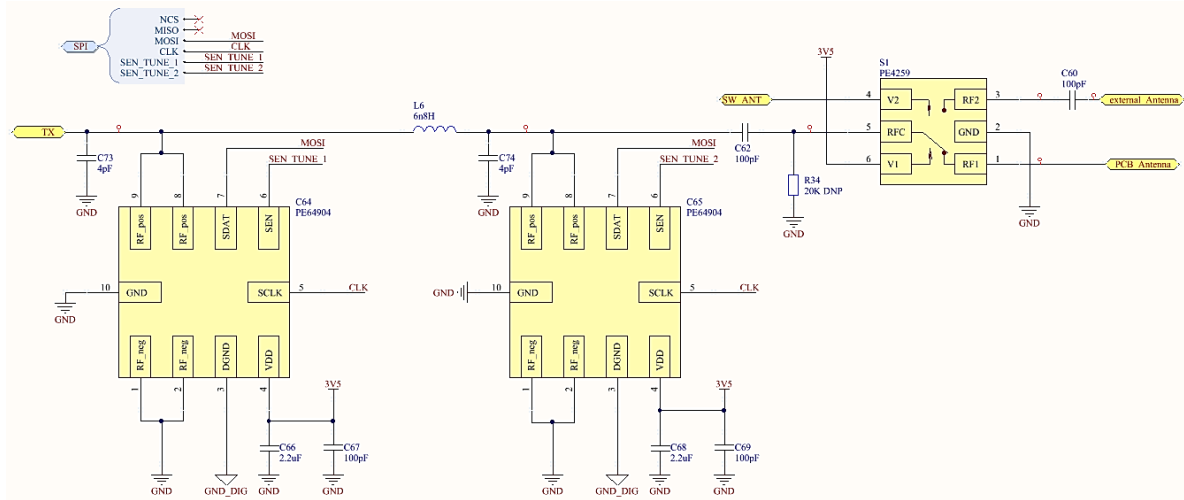

Figure 13 – Schematic Tuning Circuit

Controller Section:

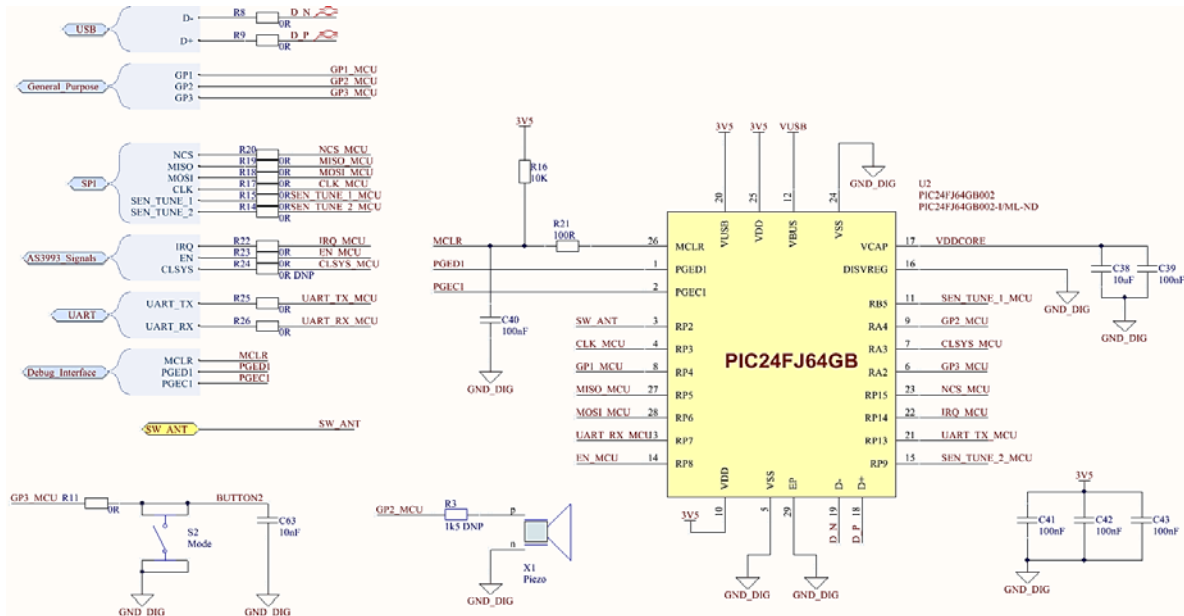

Figure 14 - Schematic Controller Section



Connector Section:

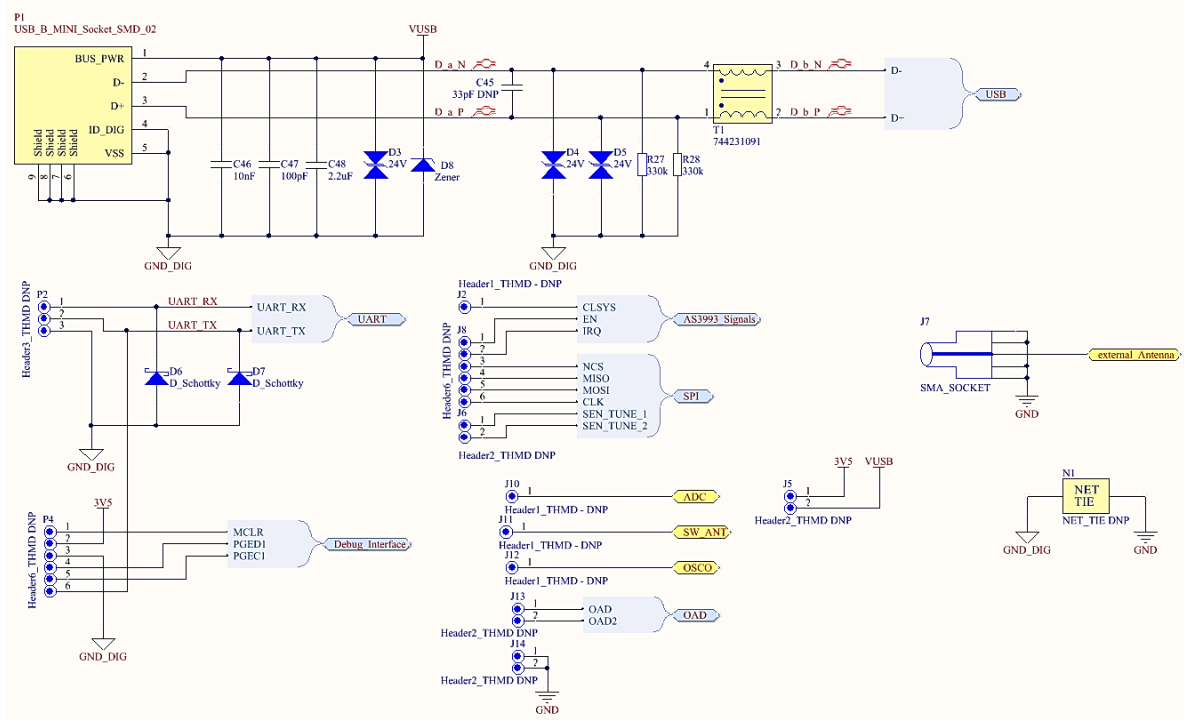

Figure 15 - Schematic Connector Section

Power Supply Section:

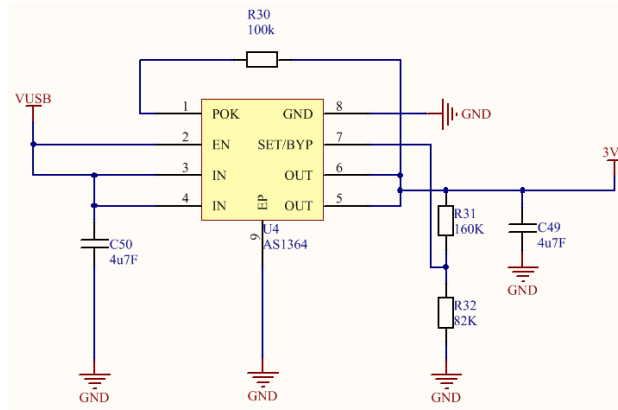

Figure 16 - Schematic Power Supply Section



## Copyright

Copyright © 1997-2012, ams AG, Tobelbader Strasse 30, 8141 Unterpremstaetten, Austria-Europe. Trademarks Registered ®. All rights reserved. The material herein may not be reproduced, adapted, merged, translated, stored, or used without the prior written consent of the copyright owner.

All products and companies mentioned are trademarks or registered trademarks of their respective companies.

## Disclaimer

Devices sold by ams AG are covered by the warranty and patent indemnification provisions appearing in its Term of Sale. ams AG makes no warranty, express, statutory, implied, or by description regarding the information set forth herein or regarding the freedom of the described devices from patent infringement. ams AG reserves the right to change specifications and prices at any time and without notice. Therefore, prior to designing this product into a system, it is necessary to check with ams AG for current information.

This product is intended for use in normal commercial applications. Applications requiring extended temperature range, unusual environmental requirements, or high reliability applications, such as military, medical life-support or lifesustaining equipment are specifically not recommended without additional processing by ams AG for each application. For shipments of less than 100 parts the manufacturing flow might show deviations from the standard production flow, such as test flow or test location.

The information furnished here by ams AG is believed to be correct and accurate. However, ams AG shall not be liable to recipient or any third party for any damages, including but not limited to personal injury, property damage, loss of profits, loss of use, interruption of business or indirect, special, incidental or consequential damages, of any kind, in connection with or arising out of the furnishing, performance or use of the technical data herein. No obligation or liability to recipient or any third party shall arise or flow out of ams AG rendering of technical or other services.

## Contact Information

### Headquarters

ams AG  
Tobelbader Strasse 30  
8141 Unterpremstaetten  
Austria

T. +43 (0) 3136 500 0

For Sales Offices, Distributors and Representatives, please visit:

<http://www.ams.com/contact>