



2 Hardware overview

Please refer to schematics, layout and BOM available at <http://www.atmel.com>.

The MC300 motor control driver board is a power stage board intended for driving BLDC and stepper motors. It has four half-bridges with independent control of high and low sides. Each bridge has options for filtered/voltage divided feedback from its output (EMF) and shunt resistor. There is also feedback from a common shunt resistor, V_{motor} (V_m) and $V_{neutral}$ (V_n - center tap motor windings).

Four 8-pin 2,54mm (100mil) horizontal female pin headers on the left side of the board form a system connector for device boards.

The board has an adjustable voltage regulator for V_{cc} , 3.3V or 5V, and this voltage is available on the system connector. A 5V regulator powers the Hall sensors. V_m , V_n and V_{cc} each have their own LED to indicate power.

2.1 Specifications

MC300 maximum ratings with components as delivered:

Input:

- V_{in} : 10 – 20VDC
- V_m : 0 – 40VDC, $I_{m_{max}} = 6A$

Output ratings:

- $V_{cc} = 3.3/5V$, $I_{max} = 0.5A$
- $V_{ha} = 5V$, $I_{max} = 0.1A$

The driver stage consists of four half-bridges capable of 40V / 30A (Warning! Other components such as shunt resistors limit the maximum current to 6A).

2.1.1 Necessary precautions

The gate voltage to the high side MOS is powered by a bootstrap capacitor. To sustain the voltage over this capacitor the **high side must be turned off for a short time on a regular basis**, allowing the capacitor to be recharged via a diode. Failing to do so, for example, by keeping the high side permanently on, will cause the gate voltage on the high side MOS to drop and the internal resistance to increase. If a high current is going thru the high side MOS at this point the transistor will overheat and be destroyed. The fuse will not prevent this from happening.

2.2 Connections

Figure 2-1. MC300 with device board, connector details and prototype board fitted.

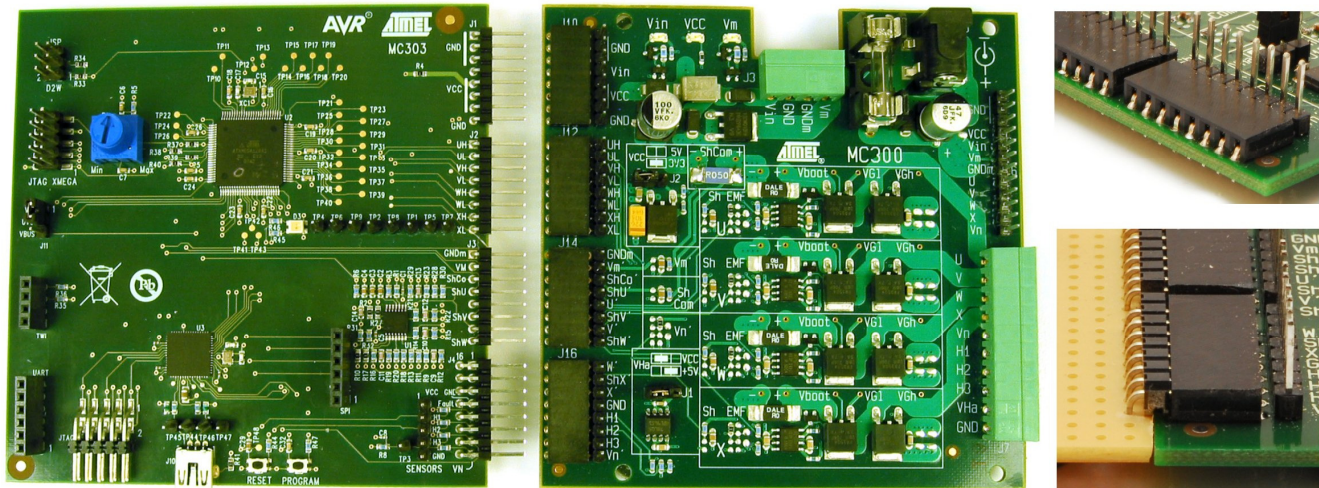

2.2.1 Device board connector

The MC300 driver board can directly connect to an AVR device board. This is accomplished by a horizontal female 0.1" pin header connector located on the left side of the board, shown in Figure 2-1.

The device board interface on MC300 connector is split into four eight-pin connectors. Electric schematics and mechanical specifications are shown in Figure 2-2 and signal description in Table 2-2.

The connectors are mounted on the same 0.1" grid. The grid is positioned so the connectors will fit an angled pin header on a prototype Vero-board, shown in Figure 2-1.

2.2.2 Power and motor connectors

The board has two power connectors located on the top, one 4 pin 3.81mm connector (J3) and one DC-jack (J5) with 2.0mm center tap. J3 allows for separate power inputs to V_{in} and V_m , while J5 powers both V_{in} and V_m via diodes. Refer to chapter 4.1 for more details.

The motor connector (J7), a 10 pin 3.81mm connector, is found on the lower right side of the board. Signals and voltages associated with the motor are easy accessible on the pin row (J6) above the motor connector. Refer to the schematics for signals and pinout on J6 and J7.



Figure 2-2. Device board connector mechanical specification and schematics.

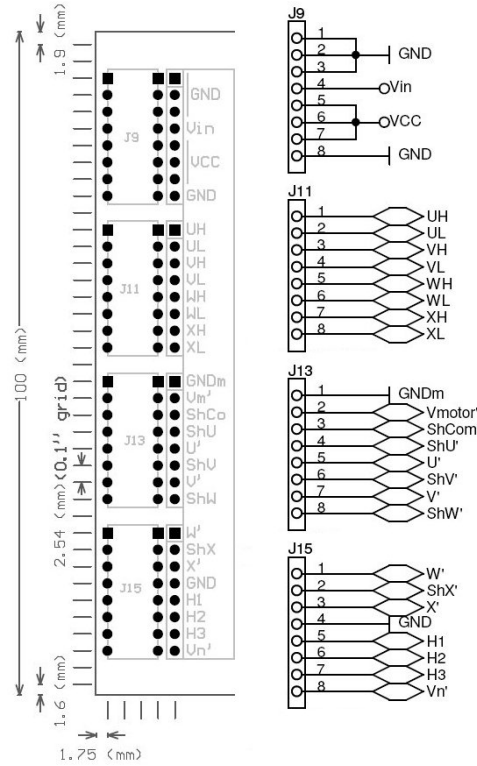

2.3 Jumpers

Refer to component floorplan for location of jumpers.

Table 2-1. Jumpers and their functions.

Designator	Use and settings
J1 (VHa)	Selects voltage source to Hall sensors (VHa) J1 open – VHa not connected J1 pin 2 & 3 connected – VHa = Vcc J1 pin 1 & 2 connected – VHa = 5V (from separate regulator)
J2 (VCC)	Selects voltage from onboard regulated supply (Vcc). J2 connected – Vcc = 3.3V J2 open – Vcc = 5V

Table 2-2. MC300 device board connector signal description.

Pin	Located	Name	Direction	Description
1	J9p1	GND	-	
2	J9p2	GND	-	System ground (Vin/VCC)
3	J9p3	GND	-	
4	J9p4	Vin	Output	Input power Vin (10-20V)
5	J9p5	VCC	Output	
6	J9p6	VCC	Output	Regulated power Vcc (3.3V/5V)
7	J9p7	VCC	Output	
8	J9p8	GND	-	System ground (Vin/VCC)
9	J11p1	UH	Input	Phase U Highside control input
10	J11p2	UL	Input	Phase U Lowside control input
11	J11p3	VH	Input	Phase V Highside control input
12	J11p4	VL	Input	Phase V Lowside control input
13	J11p5	WH	Input	Phase W Highside control input
14	J11p6	WL	Input	Phase W Lowside control input
15	J11p7	XH	Input	Phase X Highside control input
16	J11p8	XL	Input	Phase X Lowside control input
17	J13p1	GNDm	-	Motor ground (Vmotor)
18	J13p2	Vmotor'	Output	Vmotor filtered/divided
19	J13p3	ShCom'	Output	Voltage over ShCom filtered/divided
20	J13p4	ShU'	Output	Voltage over ShU filtered/divided
21	J13p5	U'	Output	BackEMF phase U filtered/divided
22	J13p6	ShV'	Output	Voltage over ShV filtered/divided
23	J13p7	V'	Output	BackEMF phase V filtered/divided
24	J13p8	ShW'	Output	Voltage over ShW filtered/divided
25	J15p1	W'	Output	BackEMF phase W filtered/divided
26	J15p2	ShX'	Output	Voltage over ShX filtered/divided
27	J15p3	X'	Output	BackEMF phase X filtered/divided
28	J15p4	GND	-	System ground (Vin/VCC)
29	J15p5	H1	Output	Hall sensor 1 signal
30	J15p6	H2	Output	Hall sensor 2 signal
31	J15p7	H3	Output	Hall sensor 3 signal
32	J15p8	Vn'	Output	Vn (neutral point) filtered/divided

3 PCB

3.1 PCB Layout

The MC300 is organized as shown in Figure 3-1. Most signals, important components and jumper information are written on the silk screen. For individual component placement refer to the component floorplan.

Figure 3-1. MC300 PCB layout.

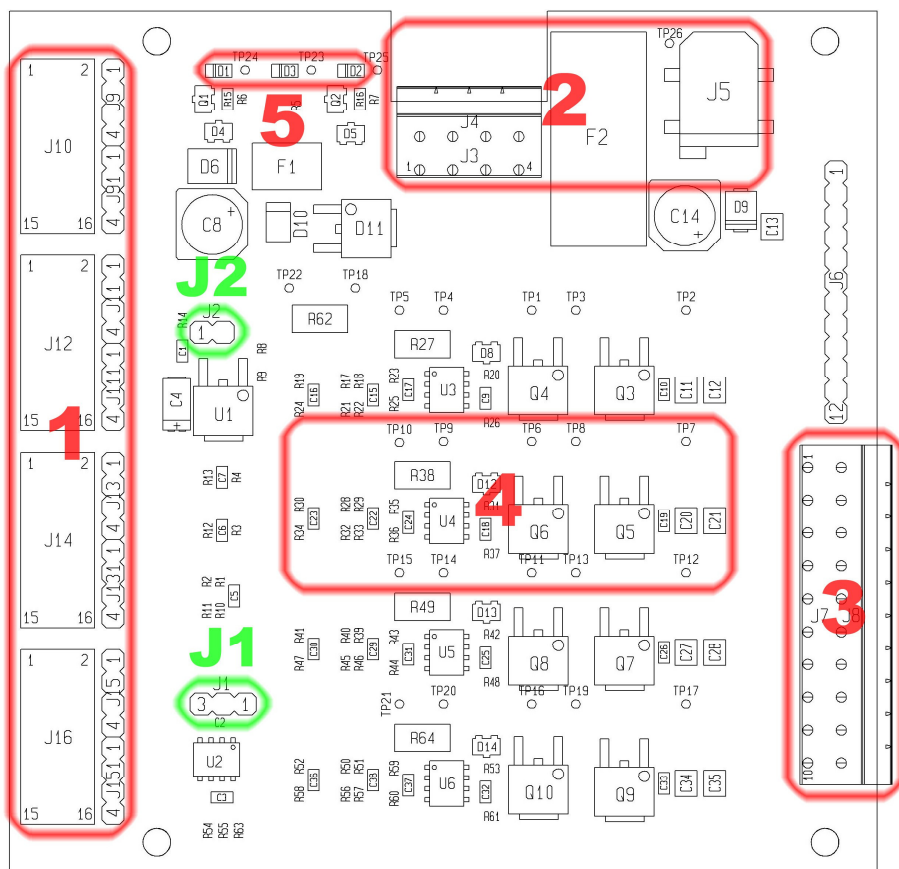

In Figure 3-1 the following areas are marked:

1. Device board connector.
2. Power connectors
3. Motor connector
4. Phase area
5. Indicator LEDs for power

3.1.1 Phase area

Each phase has its own area with a frame drawn on silkscreen. In Figure 3-2 the area for phase 'V' is shown, and everything inside this frame regards this phase only.

Figure 3-2. Phase 'V' area on MC300 PCB.

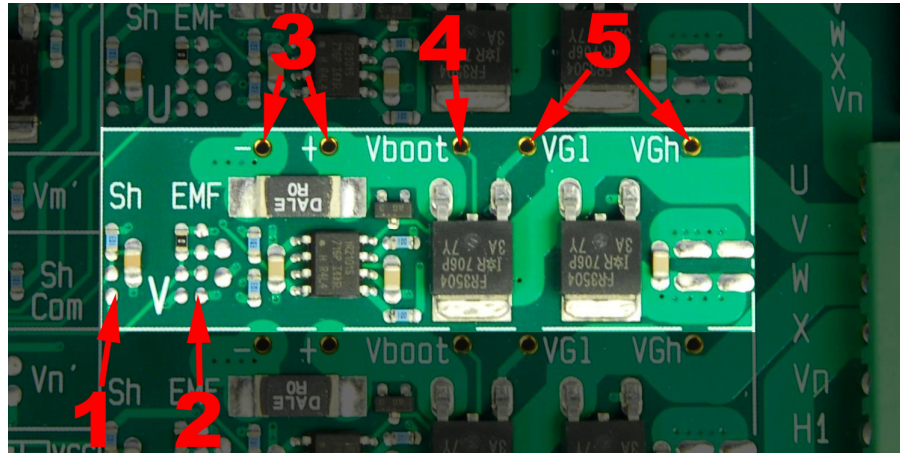

From the left we see:

1. Shunt filter/damping block – denoted 'Sh'
2. Back EMF filter/damping block – denoted 'EMF'
3. Shunt resistor testpoints – denoted '-' and '+' (above shunt resistor)
4. Bootstrap voltage testpoint – denoted 'Vboot'
5. MOS Gate voltage testpoints – denoted 'VG1' (low side) and 'VGh' (high side)

3.1.2 Common shunt and filters/dividers

The common shunt (R62) with testpoints is found above phase 'U' and denoted 'ShCom'. Filters/dividers for Vm, ShCom and Vn are found on the left of the phase areas.

3.2 Schematics, component floorplan and bill of materials

The schematics, component floorplan and bill of materials (BOM) for MC300 are found as separate PDF files distributed with this application note, they can be downloaded from <http://www.atmel.com>.

4 Detailed description

4.1 Power

The MC300 has two power circuits. V_{in} for powering driver ICs and voltage regulators, and V_{motor} (V_m) for powering the output stage (MOSFETs). The separate power supply for the motor, V_m , allows the use of motor voltages outside the voltage range of the driver ICs. This also isolates noise generated by the output stage/motor.

There is a separate ground plane for each power circuit, GND for V_{in} and GND_{motor} (GND_m) for V_m . This is done to separate the high currents to the motor from the rest. The ground planes are connected together at one single point, under the J3 connector (shown in Figure 4-1).

A regulated power supply for V_{cc} is included on the board. The voltage for V_{cc} is selectable by J2, if open $V_{cc} = 5V$ and if set $V_{cc} = 3.3V$.

4.1.1 Input

The MC300 can be powered in two ways. With J3, a four pin 3,81 mm pitch connector, separate power supplies can be connected to V_{in} and V_m . But it is also possible to power the MC300 from a single DC-Jack connector, J5. J5 is connected to V_{in} and V_m via diodes as shown in Figure 4-1. When J5 is used as power input, the supply voltage must not exceed 20V and maximum current is 5A.

Figure 4-1. MC300 Power input.

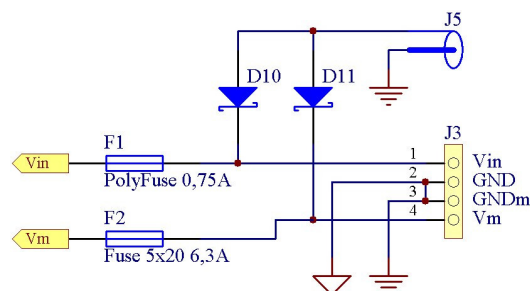

4.1.2 Fuses

V_{in} is protected by a resettable 0,75A polyfuse (F1). If the current through it exceeds 0,75A, the fuse will heat up and go into a high resistance mode for as long as the load is retained, and will reset when allowed to cool down.

A socket mounted 6,3A 5x20 mm fuse protects V_m (F2). Using a socket mounted fuse allows the user to replace and change it easily. When developing software it is also practical to not power the output stages until correct operation of the software is ensured, and this can be done by simply removing the fuse.

4.1.3 LEDs

V_{cc} , V_{in} and V_m each have their own green LED to indicate if voltage is present. The V_{cc} LED (D3) is connected to V_{cc} by a resistor and hence it will emit less light when V_{cc} is 3,3V. V_{in} and V_m LEDs (D1 and D2) have a constant current sources, so they have a constant intensity even if V_{in} or V_m changes.

4.1.4 Hall sensors

VHall (VHa) is available on J7 as power source for Hall sensors, typically found on BLDC motors. With J1 VHa can be connected to Vcc or to a 5V regulator (U2). A separate 5V regulator for the Hall sensors is included so Vcc can be 3,3V while using Hall sensors, since most Hall sensors will not work on 3,3V.

4.2 Half bridges

The half bridge consists of two n-channel power MOSFETs, driven by an integrated high and low side driver IC (IR2101S). The integrated driver IC is powered from Vin and provides gate voltages to the high and low side power MOSFETs. Schematics for the half bridge for phase U is shown in Figure 4-2

Figure 4-2. Phase U half bridge.

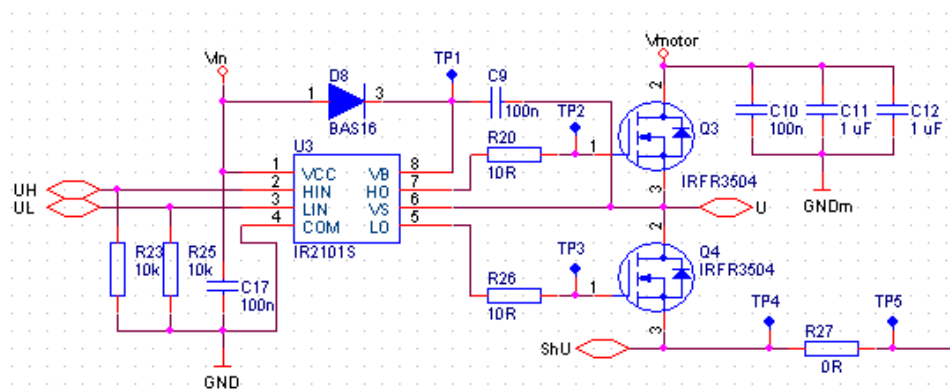

4.2.1 High side driving considerations

The high side of the half-bridge uses a bootstrap circuit. This means the duty cycle and the on-time are limited by the requirement to refresh the charge in the bootstrap capacitor. If the driving logic fails to do this, the gate voltage to the high side MOS will decrease and the R_{DS} will increase. This may result in high power dissipation in the high side MOS, and consequently destroy it.

Refer with IR2101S datasheets for detailed information about the bootstrap circuit.

4.2.2 Test points

Each half bridge has several testpoints to allow for measurements. MOS gate voltages for high (VGh) and low-side (VGl) and bootstrap voltage (Vboot) are available. Both sides of the shunt resistors (- and +) can also be measured.

4.3 Shunts

The board is shipped with a common shunt resistor (ShCom - R62) of 0,050 ohm and the four phase shunt resistors are zero ohm resistors, shown in Figure 4-3. This allows for measurement of the total current going to ground via all half bridges.

Figure 4-3. Shunt resistor network.

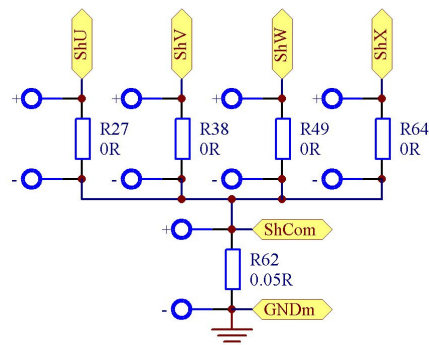

If current measurements of separate phases are required, the common shunt should be changed to a zero ohm resistor and the zero ohm resistors on each phase (ShU - R27, ShV - R38, ShW - R49 and ShX - R64) should be replaced with appropriate shunt resistors.

4.3.1 Shunt feedback filters

The voltages over the shunt resistors (ShCom/ShU/V/W/X) are fed to a filter/damping block, ShU as shown in Figure 4-4. The board is shipped with a filter that consists of a 10k ohm resistor in series with a 10nF capacitor, resulting in a low pass filter with a 1,6kHz cutoff frequency. The signal from the filters (ShCom'/ShU'/V'/W'/X') are available on the device board interface.

Figure 4-4. Filter/damping block for shunt feedback.

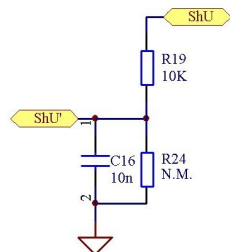

4.4 Back-EMF

For sensorless applications, the driving logic uses back EMF from the motor's phases to keep track of the motor position. To observe the back EMF from a phase, the phase is left floating, i.e. with the high or low side MOS not powered, and the voltage on the phase is read. For motors with center tap, Vn (V neutral) provides feedback to device board.

4.4.1 Back-EMF feedback filters

Each phase (U/V/W/X) and the center tap (Vn) are fed via a filter/damping block to the device board interface. The block for phase U is shown in Figure 4-5. The board is shipped with a zero ohm resistor, so it has no damping/filter function. The signals are named U', V', W', X' and Vn' after going through the filter blocks.

Vmotor (Vm) is also fed thru a filter/damping block, and is available on the device board interface as Vm'.

Figure 4-5. Filter/damping block for back-EMF feedback.

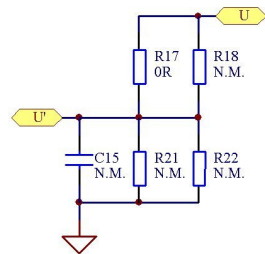



4.5 Upgrading the MC300

As the board is shipped, its limitations are $V_{m_{max}}=40V$ and $I_{m_{max}}=6A$. These limits can be increased by replacing the relevant components (not included).

4.5.1 Voltage limitations

If a $V_{m_{max}}$ higher than 40V is required, then some components must be changed on the board. Components limiting V_m , listed with lowest voltage ratings first, are shown in Table 4-1.

Table 4-1. Components influenced by V_m .

Component designator(s)	Component name	Limiting parameter
Q3, Q4, Q5, Q6, Q7, Q8, Q9 & Q10	IRFR3504	$V_{DSS} = 40V$
C10, C19, C26 & C33	100nF	$V_{max} = 50V$
Q2	2N7002	$V_{DSmax} = 60V$
C14	47uF/63V	$V_{max} = 63V$
D8, D12, D13 & D14	BAS16	$V_{RRM} = 85V$
D9	10MQ100N	$V_{RRM} = 100V$
D11	12CWQ10FN	$V_{RRM} = 100V$
C7	10nF	$V_{max} = 100V$ [2]
R7	100kOhm	$P_{max} = 0.1W \rightarrow V_m = 108V$

The integrated bridge drivers (IR2101S) can handle up to 600V, but the layout of the PCB (spacing between tracks) should be considered before operation at high voltages.

If filters/dividers for V_m , U, V, W, or X have been mounted, verify that they can handle V_m .

4.5.2 Current limitations

For an $I_m > 5A$, use power connector J3 and not DC-Jack J5. If an $I_{m_{max}}$ larger than 6A is required, components listed in Table 4-2 are affected.

Table 4-2. Components conducting I_m .

Component designator(s)	Component name	Limiting parameter
R62	50mOhm 2W	$I_{max} = \sqrt{P/R} = 6,0A$ ⁽¹⁾
J3 & J7	MC1,5/x-G-3,81	$I_{max} = 8A$
Q3, Q4, Q5, Q6, Q7, Q8, Q9 & Q10	IRFR3504	$I_D = 30A$

Notes: 1. The pad/track area around R62 is not 300mm² as required by datasheet for handling 2W. Reducing P to 1,8W gives $I_{max} = \sqrt{P/R} = 6,0A$.

4.5.3 Additional decoupling capacitors on V_m

The board has provision for some extra decoupling capacitors on V_m . They are found close to the MOS bridges (C11, C12, C20, C21, C27, C28, C34 and C35), and one close to the power input (C13).



Headquarters

Atmel Corporation
2325 Orchard Parkway
San Jose, CA 95131
USA
Tel: 1(408) 441-0311
Fax: 1(408) 487-2600

International

Atmel Asia
Room 1219
Chinachem Golden Plaza
77 Mody Road Tsimshatsui
East Kowloon
Hong Kong
Tel: (852) 2721-9778
Fax: (852) 2722-1369

Atmel Europe
Le Krebs
8, Rue Jean-Pierre Timbaud
BP 309
78054 Saint-Quentin-en-
Yvelines Cedex
France
Tel: (33) 1-30-60-70-00
Fax: (33) 1-30-60-71-11

Atmel Japan
9F, Tonetsu Shinkawa Bldg.
1-24-8 Shinkawa
Chuo-ku, Tokyo 104-0033
Japan
Tel: (81) 3-3523-3551
Fax: (81) 3-3523-7581

Product Contact

Web Site
www.atmel.com

Technical Support
avr@atmel.com

Sales Contact
www.atmel.com/contacts

Literature Request
www.atmel.com/literature

Disclaimer: The information in this document is provided in connection with Atmel products. No license, express or implied, by estoppel or otherwise, to any intellectual property right is granted by this document or in connection with the sale of Atmel products. **EXCEPT AS SET FORTH IN ATMEL'S TERMS AND CONDITIONS OF SALE LOCATED ON ATMEL'S WEB SITE, ATMEL ASSUMES NO LIABILITY WHATSOEVER AND DISCLAIMS ANY EXPRESS, IMPLIED OR STATUTORY WARRANTY RELATING TO ITS PRODUCTS INCLUDING, BUT NOT LIMITED TO, THE IMPLIED WARRANTY OF MERCHANTABILITY, FITNESS FOR A PARTICULAR PURPOSE, OR NON-INFRINGEMENT. IN NO EVENT SHALL ATMEL BE LIABLE FOR ANY DIRECT, INDIRECT, CONSEQUENTIAL, PUNITIVE, SPECIAL OR INCIDENTAL DAMAGES (INCLUDING, WITHOUT LIMITATION, DAMAGES FOR LOSS OF PROFITS, BUSINESS INTERRUPTION, OR LOSS OF INFORMATION) ARISING OUT OF THE USE OR INABILITY TO USE THIS DOCUMENT, EVEN IF ATMEL HAS BEEN ADVISED OF THE POSSIBILITY OF SUCH DAMAGES.** Atmel makes no representations or warranties with respect to the accuracy or completeness of the contents of this document and reserves the right to make changes to specifications and product descriptions at any time without notice. Atmel does not make any commitment to update the information contained herein. Unless specifically provided otherwise, Atmel products are not suitable for, and shall not be used in, automotive applications. Atmel's products are not intended, authorized, or warranted for use as components in applications intended to support or sustain life.

© 2008 Atmel Corporation. All rights reserved. Atmel®, logo and combinations thereof, AVR® and others, are the registered trademarks or trademarks of Atmel Corporation or its subsidiaries. Other terms and product names may be trademarks of others.