

# APDS-9004

## Miniature Surface-Mount Ambient Light Photo Sensor



### Data Sheet



#### Description

The APDS-9004 is a low cost analog-output ambient light photo sensor in miniature chipLED lead-free, reverse surface mount package. It consists of a photo sensor, whose spectral response is close to CIE standard photopic observer. Hence, it provides an excellent responsivity that is close to the response of human eyes, as shown in Figure 2. It is suitable for portable applications with its ultra small package design.

The APDS-9004 is ideal for applications in which the measurement of ambient light is used to control display backlighting. Mobile appliances such as the mobile phones and PDAs that draw heavy current from display backlighting will benefit from incorporating these photo sensor products in their designs by reducing power consumption significantly.

#### Features

- Spectral responsivity close to that of human eye
- ChipLED Reverse surface-mount package
  - Height – 1.10mm
  - Width – 3.20mm
  - Depth – 1.60mm
- Good output linearity across wide illumination range
- Low sensitivity variation across various light sources
- Operating temperature
  - 40°C to 85°C
- Vcc supply 2.4 to 5.5V
- Lead-free package, RoHS compliance.

#### Applications

- Detection of ambient light to control display backlighting
  - Mobile devices – Mobile phones, PDAs
  - Computing devices – Notebooks, Webpads
  - Consumer devices – TVs, Video Cameras, Digital Still Cameras
- Automatic Residential and Commercial Lighting Management
- Electronic Signs and Signals

**CAUTION:** It is advised that normal static precautions be taken in handling and assembly of this component to prevent damage and/or degradation which may be induced by ESD.

## Application Support Information

The Application Engineering Group is available to assist you with the application design associated with APDS-9004 ambient light photo sensor module. You can contact them through your local sales representatives for additional details.

## Ordering Information

Part Number	Packaging Type	Package	Quantity
APDS-9004-020	Tape and Reel	4-pins Chiplped package	2500

## Typical Application Circuit

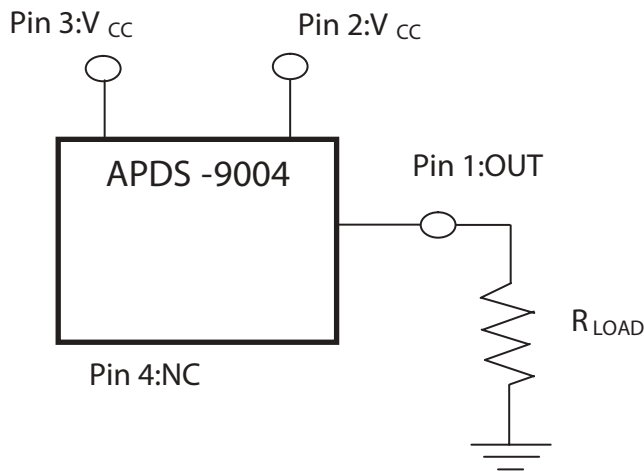

Figure 1. Typical application circuit for APDS-9004

Figure 1 Table

Component	Recommended Application Circuit Component
$R_{LOAD}$	1k ohm

## I/O Pins Configuration Table

Pin	Symbol	Description
1	OUT	OUT
2	VCC	VCC
3	VCC	VCC
4	NC	No Connect

## APDS-9004 Block Diagram

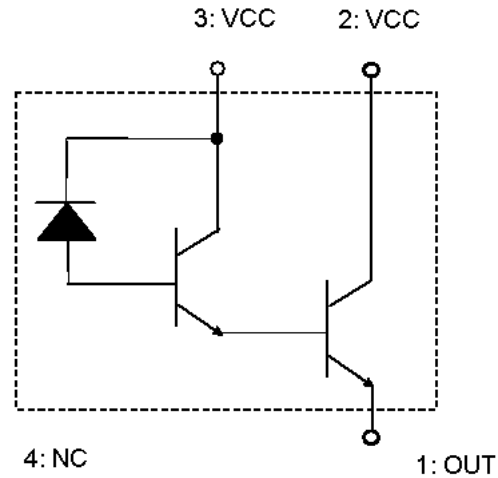

Notes : PIN 2 and PIN 3 Vcc need to be externally shorted.

Figure 2. Relative Spectral Response Vs. Wavelength

## Relative Spectral Response Vs. Wavelength

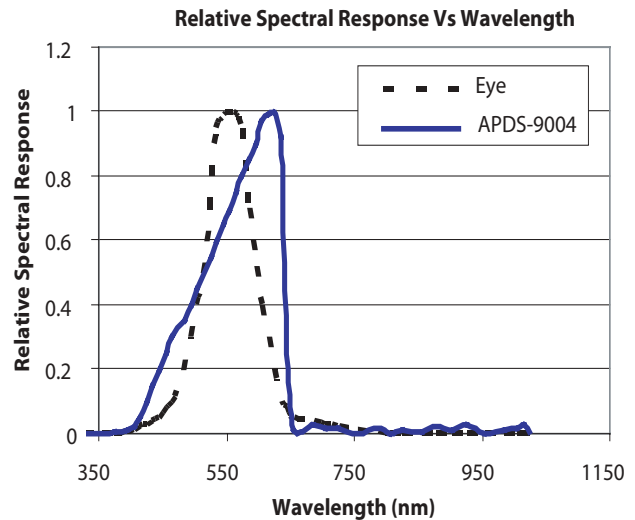

## Absolute Maximum Ratings

For implementations where case to ambient thermal resistance is  $\leq 50$  °C /W

Parameter	Symbol	Min.	Max.	Units
Storage Temperature	$T_S$	-40	85	°C
Operating Temperature	$T_A$	-40	85	°C
Supply Voltage	$V_{CC}$	0	6.0	V

## Recommended Operating Conditions

Parameter	Symbol	Min.	Max.	Units
Supply Voltage	$V_{CC}$	2.4	5.5	V

## Electrical & Optical Specifications (Ta=25°C)

Parameter	Symbol	Min.	Typ.	Max.	Units	Conditions
Output Current (I)[note4]	$I_{OUT1}$	3	19	31	uA	$V_{CC}=3.0V$ , Lux=10 [Note 2]
Output Current (II)[note4]	$I_{OUT2}$	90	230	370	uA	$V_{CC}=3.0V$ , Lux=100 [Note 2]
Output Current (III)[note4]	$I_{OUT3}$	-	276	-	uA	$V_{CC}=3.0V$ , Lux=100 [Note 1]
Dark Current	$I_{DARK}$	-	-	0.5	uA	$V_{CC}=5.0V$ , Lux=0
Light Current Ratio	$I_{OUT3}/I_{OUT2}$	-	1.2	-	-	
Saturation Output Voltage	$V_O$	2.2	2.32	-	V	$V_{CC}=3.0V$ , Lux=100, Rload=1M
Peak Sensitivity Wavelength		-	620	-	nm	
Settling Time with pulsed Vcc	Tset		3.5		ms	$V_{CC}$ pulse = 0V to 3V, Rload=1k $\Omega$ , Lux=100 [Note 3]
Propagation Delay time	Td	-	600	-	us	$V_{CC}=3.0V$ , Lux=100, Rload=1k $\Omega$ [Note 3]
Storage Delay time	Ts	-	200	-	us	$V_{CC}=3.0V$ , Lux=100, Rload=1k $\Omega$ [Note 3]
Rise Time	Tr	-	0.95		ms	$V_{CC}=3.0V$ , Lux=100, Rload=1k $\Omega$ [Note 3]
Fall Time	Tf	-	0.8		ms	$V_{CC}=3.0V$ , Lux=100, Rload=1k $\Omega$ [Note 3]

Note:

1. Illuminance by Incandescent lamp
2. Fluorescent light is used as light source. White LED is substituted in mass production.
3. White LED is used as light source.
4. Other binning options are available. Please contact your Avago Technologies representative for information on current available bins

# APDS-9004 Performance Charts

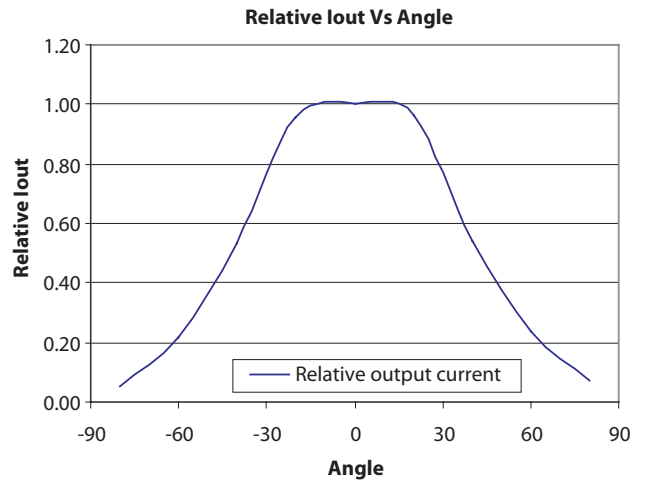
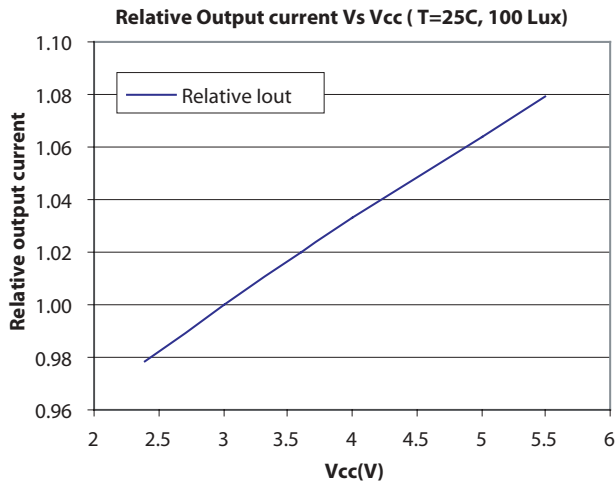
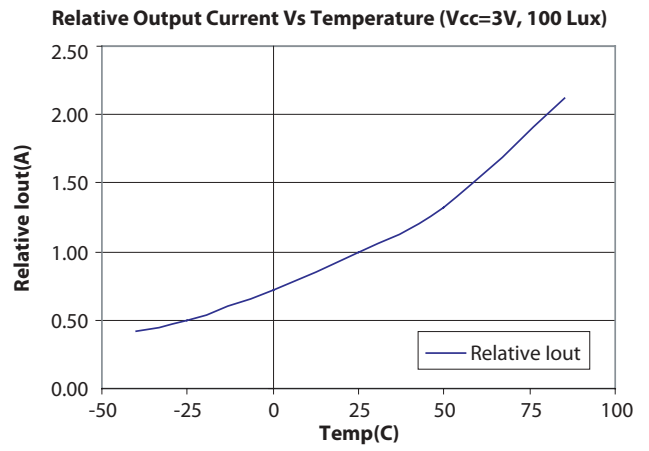
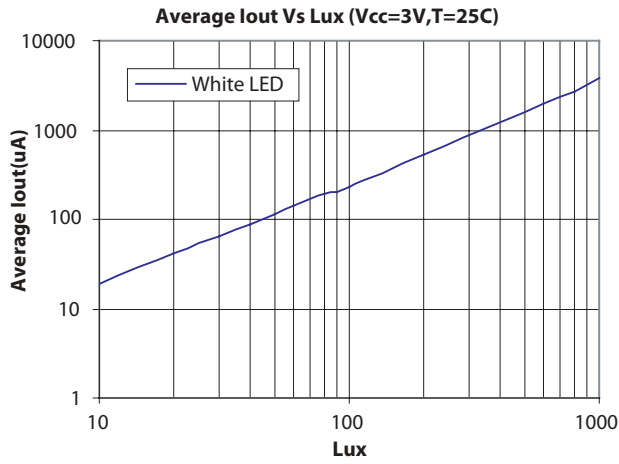

## APDS-9004 Light Measurement Circuit and Waveforms

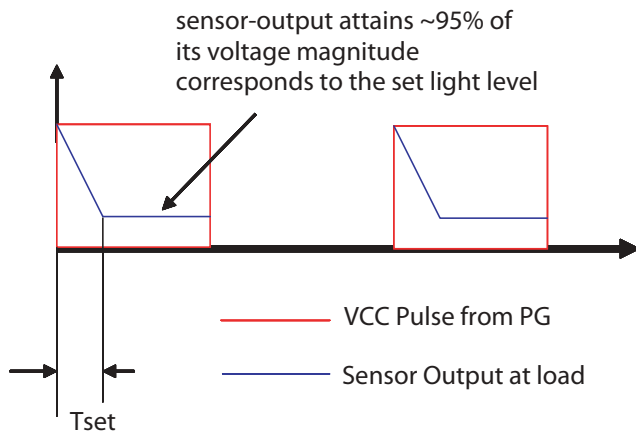
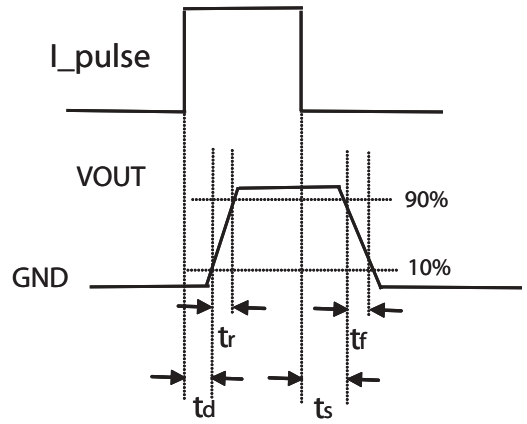
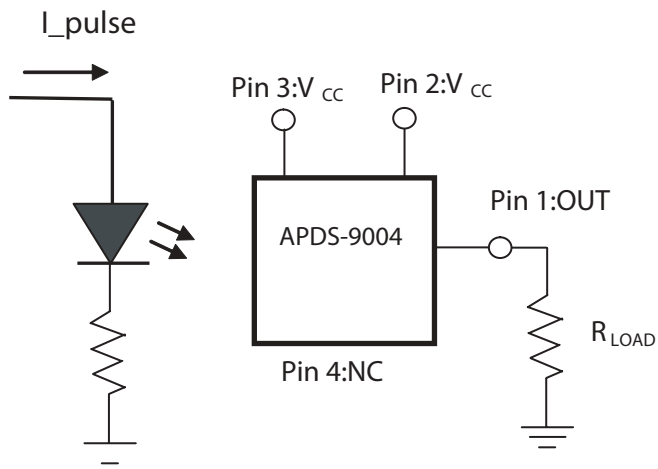

# APDS-9004 Package Outline

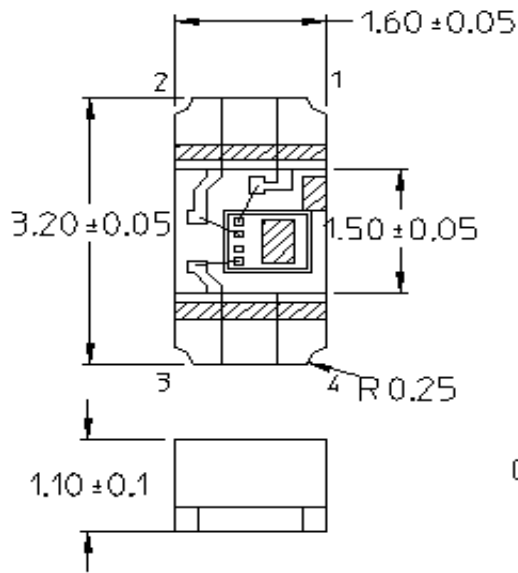

Unit : mm  
Tolerances : ±0.2 mm



Light receiving area  
(0,505mm × 0,360mm)

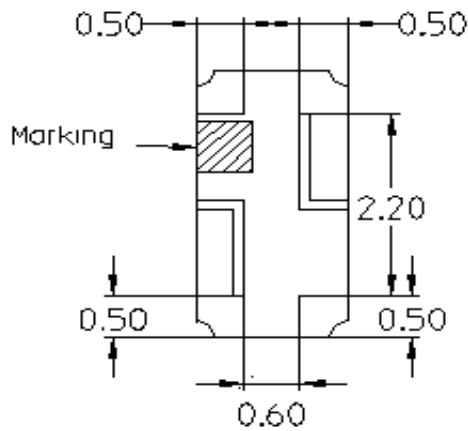
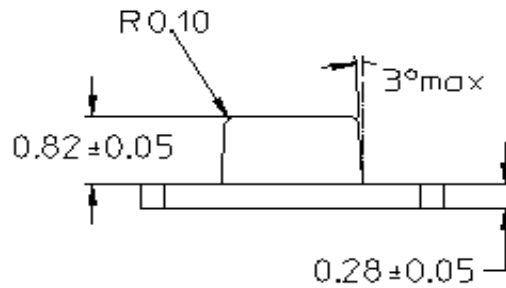

## Pin Configuration

- 1 : Out
- 2 : Vcc
- 3 : Vcc
- 4 : NC

# APDS-9004 Tape and Reel Dimensions

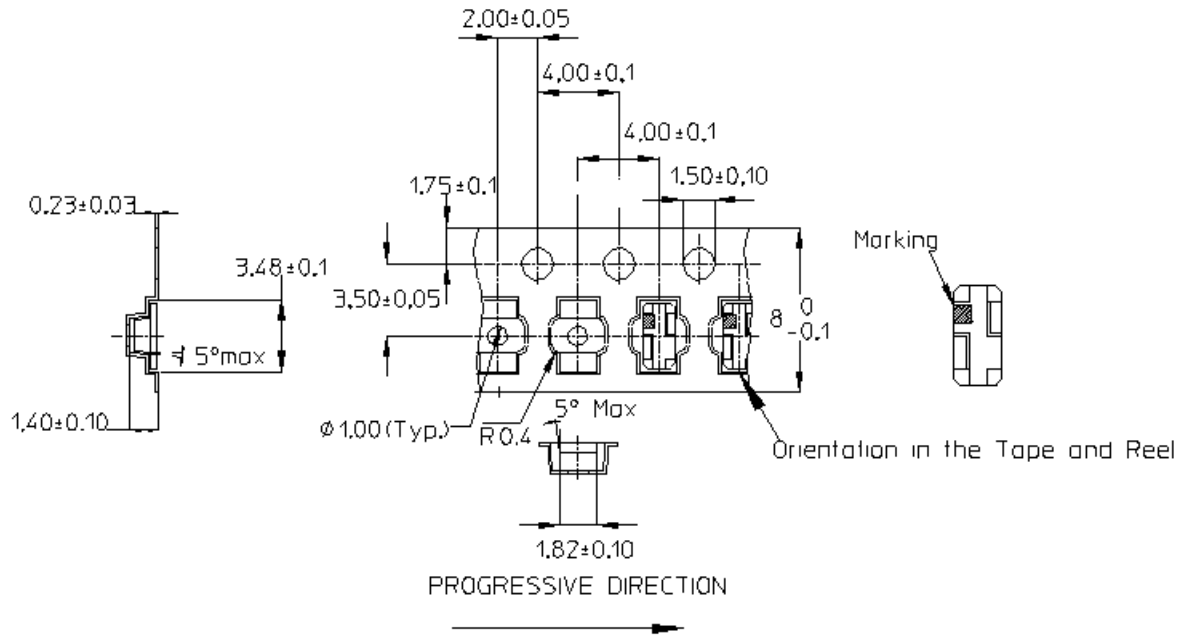

Material of Carrier Tape : Conductive Polystrene  
 Material of Cover Tape : PVC  
 Method of Cover : Heat Sensitive Adhesive

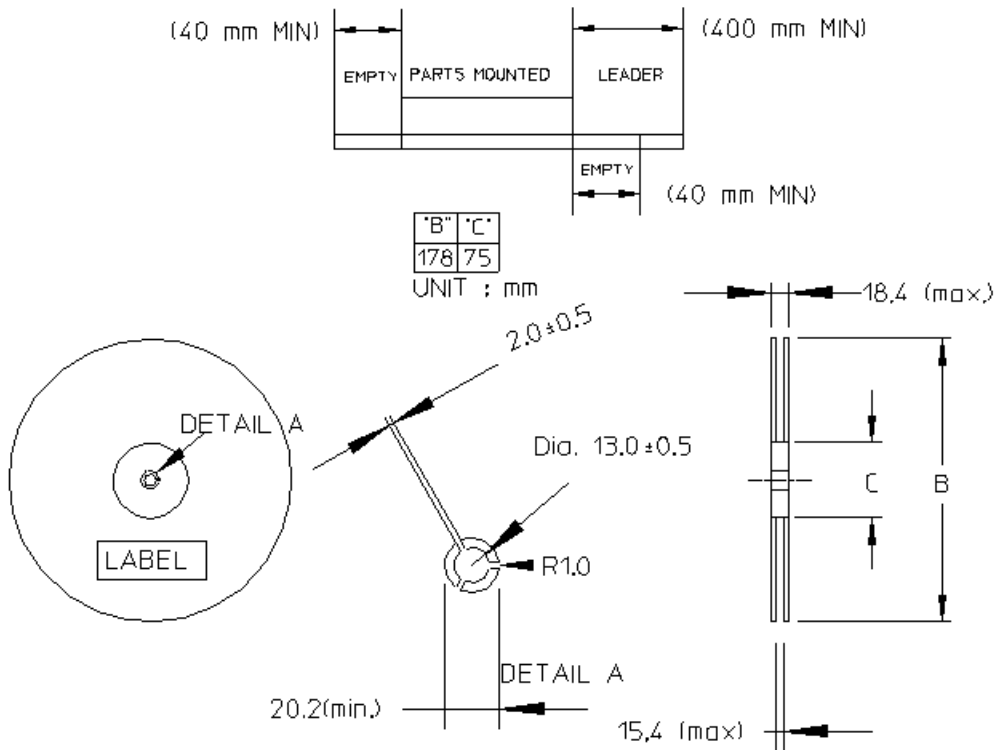

## Moisture Proof Packaging Chart

All APDS-9004 options are shipped in moisture proof package. Once opened, moisture absorption begins.

This part is compliant to JEDEC Level 3.

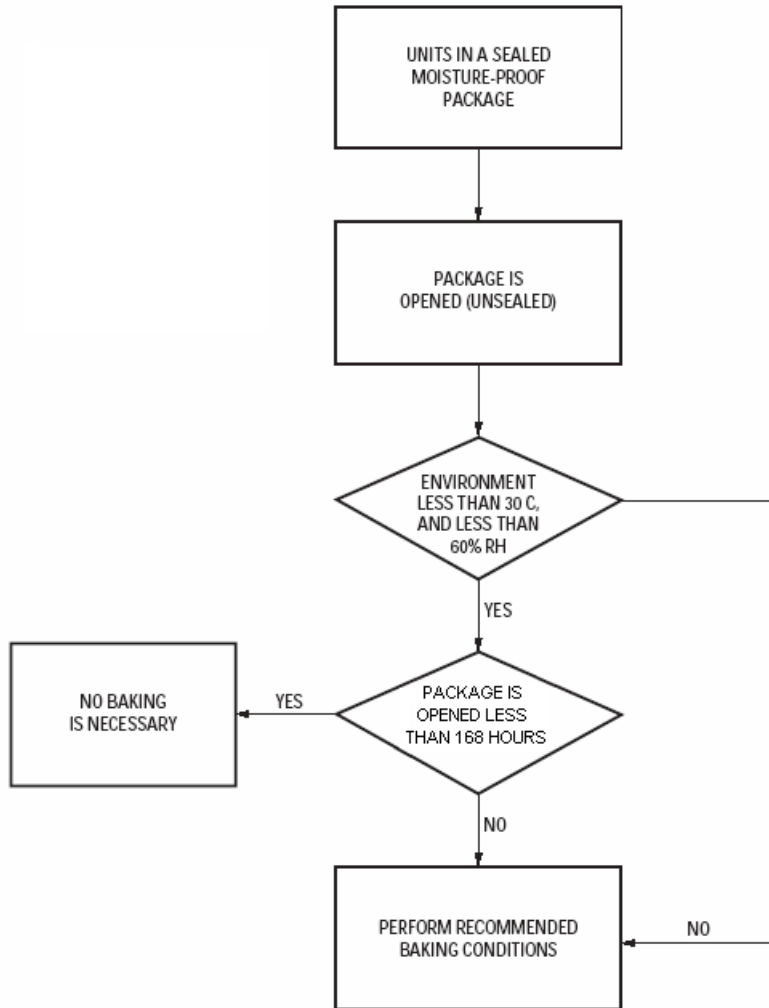

### Baking conditions

If the parts are not stored in dry conditions, they must be baked before reflow to prevent damage to the parts.

Package	Temp.	Time
In Reels	60°C	48 hours
In Bulk	100°C	6 hours

Baking should only be done once.

### Recommended Storage Conditions

Storage Temperature	10°C to 30°C
Relative Humidity	Below 60% RH

### Time from Unsealing to Soldering

After removal from the bag, the parts should be soldered within seven days if stored at the recommended storage conditions. If times longer than seven days are needed, the parts must be stored in a dry box.



## Recommended Reflow Profile

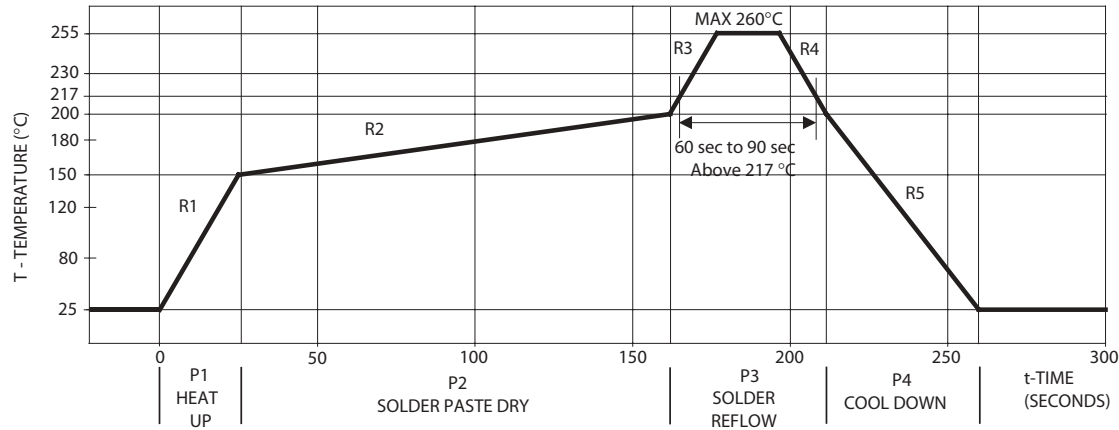

Process Zone	Symbol	T	Maximum $\Delta T$ / time or Duration
Heat Up	P1, R1	25°C to 150°C	3°C/s
Solder Paste Dry	P2, R2	150°C to 200°C	100s to 180s
Solder Reflow	P3, R3	200°C to 255°C	3°C/s
	P3, R4	255°C to 200°C	-6°C/s
Cool Down	P4, R5	200°C to 25°C	-6°C/s
Time maintained above 217°C		> 217°C	60s to 90s
Peak Temperature		260°C	
Time within 5°C of actual Peak Temperature		> 255°C	20s to 40s
Time 25°C to Peak Temperature		25°C to 260°C	8mins

The reflow profile is a straight-line representation of a nominal temperature profile for a convective reflow solder process. The temperature profile is divided into four process zones, each with different  $\Delta T/\Delta t$  temperature change rates or duration. The  $\Delta T/\Delta t$  rates or duration are detailed in the above table. The temperatures are measured at the component to printed circuit board connections.

In **process zone P1**, the PC board and APDS-9004 pins are heated to a temperature of 150°C to activate the flux in the solder paste. The temperature ramp up rate, R1, is limited to 3°C per second to allow for even heating of both the PC board and APDS-9004 pins.

**Process zone P2** should be of sufficient time duration (100 to 180 seconds) to dry the solder paste. The temperature is raised to a level just below the liquidus point of the solder, usually 200°C (392°F).

**Process zone P3** is the solder reflow zone. In zone P3, the temperature is quickly raised above the liquidus point of solder to 255°C (491°F) for optimum results.

The dwell time above the liquidus point of solder should be between 20 and 40 seconds. It usually takes about 20 seconds to assure proper coalescing of the solder balls into liquid solder and the formation of good solder connections. Beyond a dwell time of 40 seconds, the intermetallic growth within the solder connections becomes excessive, resulting in the formation of weak and unreliable connections. The temperature is then rapidly reduced to a point below the solidus temperature of the solder, usually 200°C (392°F), to allow the solder within the connections to freeze solid.

**Process zone P4** is the cool down after solder freeze. The cool down rate, R5, from the liquidus point of the solder to 25°C (77°F) should not exceed 6°C per second maximum. This limitation is necessary to allow the PC board and APDS-9004 pins to change dimensions evenly, putting minimal stresses on the APDS-9004.

It is recommended to perform reflow soldering no more than twice.

# Appendix A: SMT Assembly Application Note

## Solder Pad, Mask and Metal

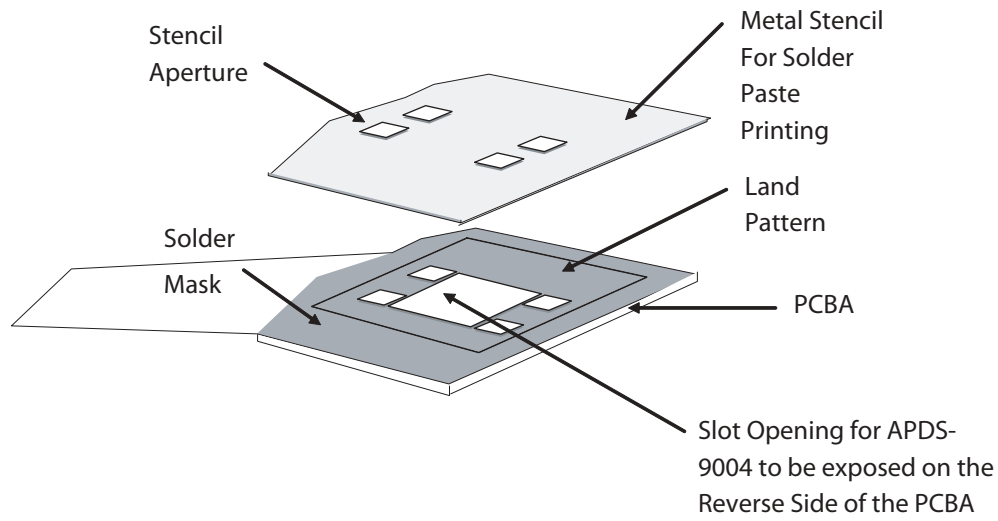

Figure 1. Stencil and PCBA

### 1.1 Recommended Land Pattern

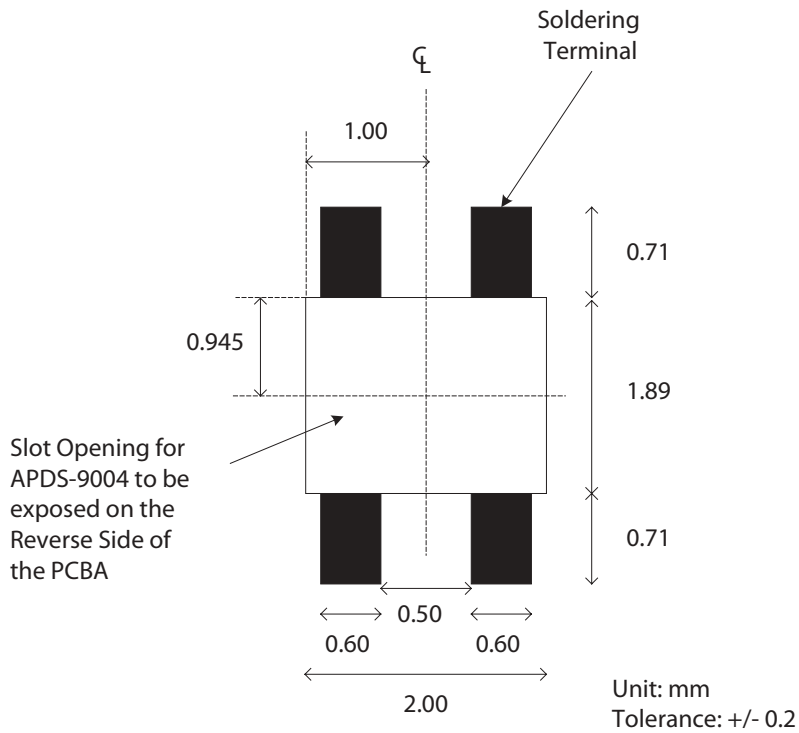

Figure 2. Recommended Land Pattern

### 1.2 Recommended Metal Solder Stencil Aperture

It is recommended that a 0.11 mm (0.004 inches) thick stencil be used for solder paste printing. Aperture opening for shield pad is 0.6mm x 0.71mm. This is to ensure adequate printed solder paste volume and no shorting.

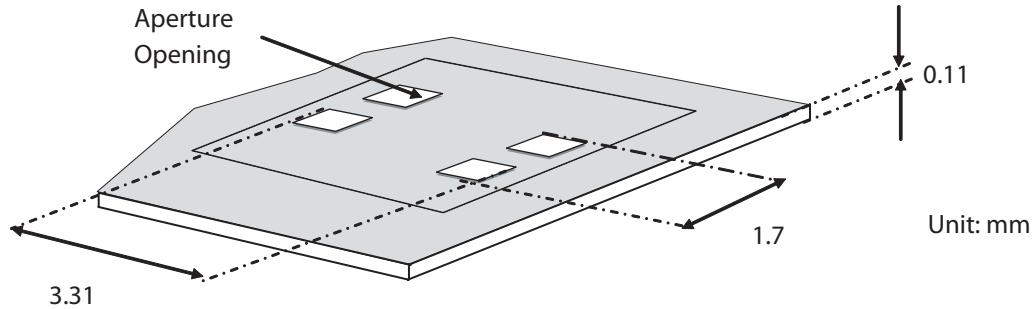

Figure 3. Solder stencil aperture

### 1.3 Adjacent Land Keepout and Solder Mask Areas

Adjacent land keep-out is the maximum space occupied by the unit relative to the land pattern. There should be no other SMD components within this area.

The minimum solder resist strip width required to avoid solder bridging adjacent pads is 0.2 mm.

Note: Wet/Liquid Photo-Imageable solder resist/mask is recommended.

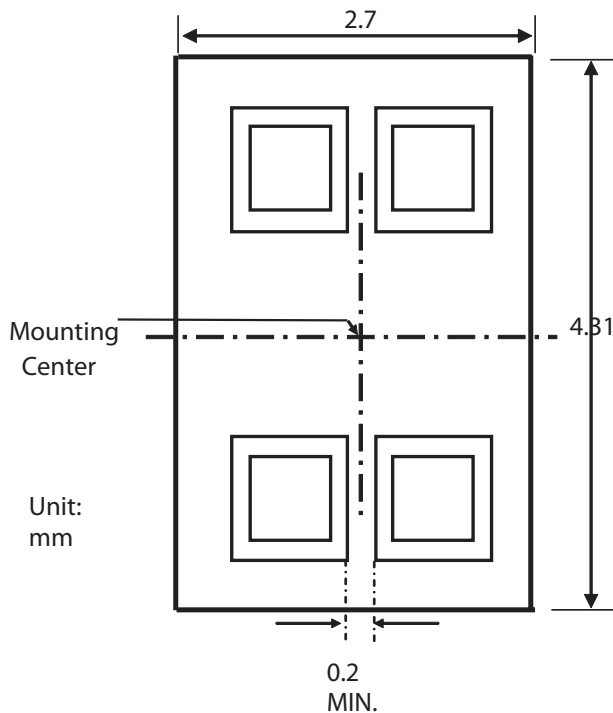

Figure 4. Adjacent land keepout and solder mask areas.

## Appendix B: Optical Window Design for APDS-9004

### Optical Window Dimensions

To ensure that the performance of the APDS-9004 will not be affected by improper window design, there are some constraints on the dimensions and design of the window. There is a constraint on the minimum size of the window, which is placed in front of the photo light sensor, so that it will not affect the angular response of the APDS-9004. This minimum dimension that is recommended will ensure at least a  $\pm 35^\circ$  light reception cone.

If a smaller window is required, a light pipe or light guide can be used. A light pipe or light guide is a

cylindrical piece of transparent plastic, which makes use of total internal reflection to focus the light.

The thickness of the window should be kept as minimum as possible because there is a loss of power in every optical window of about 8% due to reflection (4% on each side) and an additional loss of energy in the plastic material.

Figure 5a and 5b illustrate the two types of window that we have recommended which could either be a flat window or a flat window with light pipe.

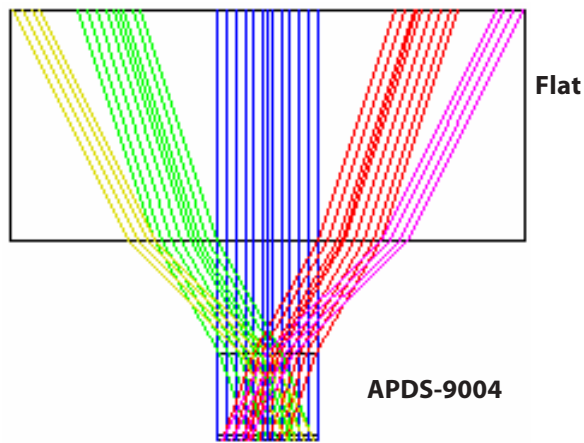

Figure 5(a). Window Size Determination for Flat Window

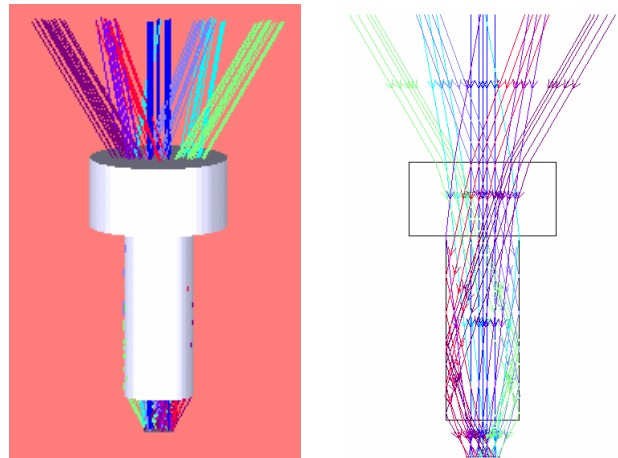

Figure 5(b). Window Design of Flat Window with Light Guide

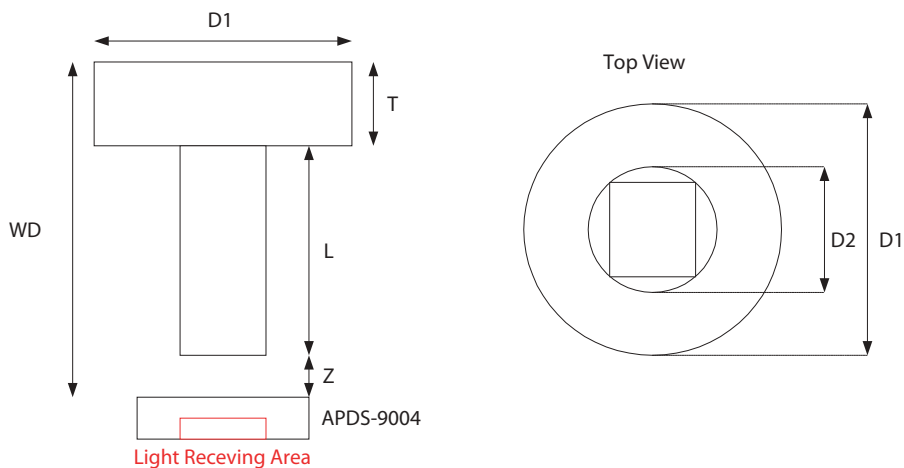

Figure 6. Recommended Window Dimensions

Table 1 and Figure 6 below show the recommended dimensions of the window. These dimension values are based on a window thickness of 1.0mm with a refractive index 1.585.

- WD: Working Distance between window front panel & APDS-9004
- D1: Window Diameter
- T: Thickness
- L: Length of Light Pipe
- D2: Light Pipe Diameter
- Z: Distance between window rear panel and APDS-9004

**Table 1: Recommended dimension for optical window**

WD (T+L+Z)	Flat Window		Flat Window with Light Guide	
	Z	D1	D1	L
1.5	0.5	2.1	-	-
2.0	1.0	2.8	-	-
2.5	1.5	3.5	-	-
3.0	2.0	4.2	2.5	1.5

( All dimensions are in mm )

Note : Active area center to coincide with window center (flat or with light guide).

The window should be placed directly on top of the photo sensor to achieve better performance and if a flat window with a light pipe is used, dimension D2 should be 1.5mm to optimize the performance of APDS-9004.

**2.1 Optical Window Material**

The material of the window is recommended to be polycarbonate. The surface finish of the plastic should be smooth, without any texture.

The recommended plastic material for use as a window is available from Bayer AG and Bayer Antwerp N. V. (Europe), Bayer Corp.(USA) and Bayer Polymers Co., Ltd. (Thailand), as shown in Table 2.

**Table 2: Recommended Plastic Materials**

Material number	Visible light transmission	Refractive index
Makrolon LQ2647	87%	1.587
Makrolon LQ3147	87%	1.587
Makrolon LQ3187	85%	1.587

## Appendix C: General Application Guide for APDS-9004

The APDS-9004 is a low cost analog-output ambient light photo sensor whose spectral response closely emulates the human eyes. APDS-9004 consists of a phototransistor that enables the photo sensor to produce a high gain photo current to a sufficient level that can be converted to voltage with a standard value of external resistor. APDS-9004 is then easily integrated into systems that use ADC input which is available for sampling of the external source, as shown in figure 7 below.

The amount of converted voltage,  $V_{out}$ , is mainly dependant proportionally on the photo current which generated by the brightness of the light shone on the photo sensor and the load resistor used,  $R_L$ . Increasing the brightness of the light or/and the load resistor will increase the output voltage.

Brightness is measured as "LUX" unit, which describes how intense a light source that our eyes perceive. LUX meter is the equipment for "LUX" measurement. Light sources with the same LUX level appear at the same brightness to the human eyes.

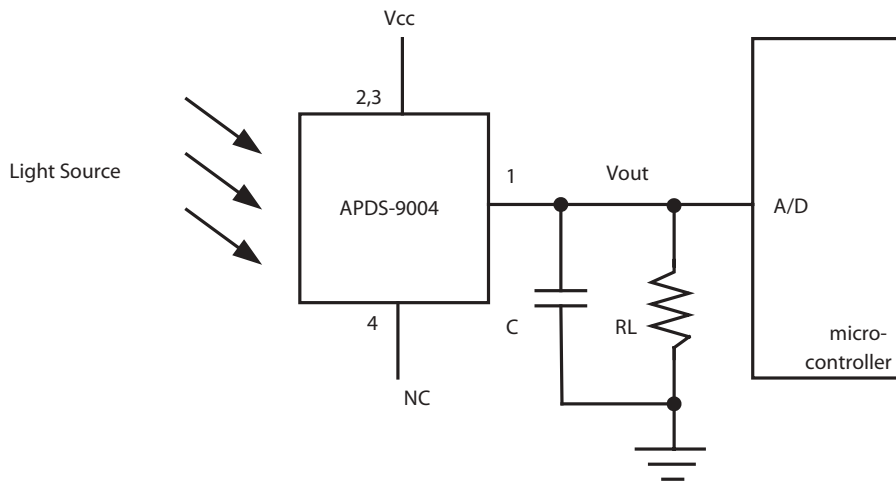

**Figure 7. Configuration of APDS-9004 being used directly**

Selection of the load resistor  $R_L$  will determine the amount of current-to-voltage conversion in the circuit.

Light source e.g. fluorescent light consists of ac noise about 100Hz frequency. A capacitor of 10 $\mu$ F, which acting as a low-pass filter, is recommended to add in parallel with the load resistor to by-pass this ripples.

For product information and a complete list of distributors, please go to our web site: [www.avagotech.com](http://www.avagotech.com)

Avago, Avago Technologies, and the A logo are trademarks of Avago Technologies, Limited in the United States and other countries. Data subject to change. Copyright © 2006 Avago Technologies Pte. All rights reserved. AV01-0184EN - September 14, 2006

**Avago**  
TECHNOLOGIES