

REV.	DESCRIPTION	DATE	APPROVED
D	Engineering Update w/o Changes	02/24/04	M. C.
E	Tolerance Update.	09/28/06	M. C.
F	Updated Material.	10/28/08	T. Y.
G	Added Ordering Information.	06/06/11	T. Y.
H	Removed Part Numbers from Part Offering List.	05/06/15	J. C.

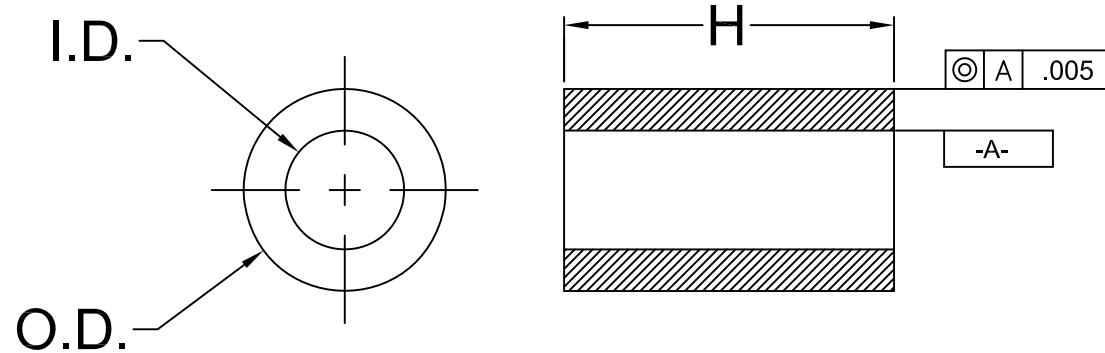

SERIES	"H" DIMENSION	I.D.	O.D.
901	.030-1.250 (.76-31.8)	.028 (.71)	.085 (2.2)
902	.030-1.250 (.76-31.8)	.032 (.81)	.125 (3.2)
903	.030-1.250 (.76-31.8)	.047 (1.2)	.156 (4.0)
904	.030-1.250 (.76-31.8)	.063 (1.6)	.187 (4.7)
905	.030-1.250 (.76-31.8)	.147 (3.7)	.250 (6.4)
906	.030-1.250 (.76-31.8)	.085 (2.2)	.148 (3.8)
907	.030-1.250 (.76-31.8)	.105 (2.7)	.167 (4.2)
908	.030-1.250 (.76-31.8)	.125 (3.2)	.187 (4.7)
911	.030-1.250 (.76-31.8)	.125 (3.2)	.250 (6.4)
912	.030-1.250 (.76-31.8)	.171 (4.3)	.250 (6.4)
913	.030-1.250 (.76-31.8)	.091 (2.3)	.187 (4.7)
937	.030-1.250 (.76-31.8)	.090 (2.3)	.125 (3.2)
938	.030-1.250 (.76-31.8)	.032 (.81)	.085 (2.2)
939	.030-1.250 (.76-31.8)	.047 (1.2)	.125 (3.2)
940	.030-1.250 (.76-31.8)	.063 (1.6)	.156 (4.0)

ORDERING INFORMATION:

**9XX-XXX**

SERIES — LENGTH  
 INCHES, MULTIPLES OF .005"  
 .030" = 030  
 .100" = 100  
 1.250" = 1.250  
 WHOLE MILLIMETERS  
 2mm = 2MM  
 5mm = 5MM

3. TOLERANCE "H" DIMENSION:

0.030 - 0.500 (1.0 - 12.7mm)±0.005(0.1mm)  
 0.505 - 0.750 (12.8 - 19.1mm)±0.008(0.2mm)  
 0.755 - 1.250 (19.2 - 31.8mm)±0.015(0.4mm)

2. MATERIAL: NYLON 6, ULTRAMID 8270 HS, NATURAL. BIVAR MATERIAL CODE 01-NL-WE.

1. GENERAL SPECIFICATIONS: BIVAR EXTRUDED PRODUCT SPECIFICATION BV00-E103.

STANDARD TOLERANCE ( UNLESS OTHERWISE SPECIFIED )		BIVAR®	
DECIMALS	ANGULAR	4 THOMAS, IRVINE, CA. 92618 TEL: (949) 951-8808 FAX: (949) 951-3974	
.X ±.1	X° ± 1°	TITLE: NYLON TUBE SPACERS	
.XX ±.01		DESIGNED: <b>Michael Chen</b>	DATE: <b>01/13/03</b>
.XXX ±.005		CHECKED: <b>D. Green</b>	DATE: <b>01/13/03</b>
		PART NO: <b>9XX-XXX</b>	REVISION: <b>H</b>
		CAGE CODE : <b>32559</b>	SHEET # <b>1</b> OF <b>1</b>
CAD GENERATED DOCUMENT, DO NOT MEASURE DRAWING.			