



MeshConnect™ Module Series

Module and Extended Range Module

Integrated Transceiver Modules for IEEE 802.15.4

Development Kits available: ZICM2410P0-KIT2-1, ZICM2410P2-KIT1-1

DESCRIPTION

CEL's MeshConnect™ Module Series provides high performance and low cost 2.4 GHz IEEE 802.15.4 modules for a broad range of wireless networks. The MeshConnect certified and qualified modules, enable customer to accelerate time to market by greatly reducing design and certification phases of development.

CEL's MeshConnect™ radio modules leverage the advanced features of the MeshConnect™ Integrated Circuit (IC). The IC is a true single-chip solution, compliant with IEEE 802.15.4 specifications, a complete wireless solution for all applications. The IC consists of an RF transceiver with baseband modem, a hardwired MAC and an embedded 8051 microcontroller with internal Flash memory. The device provides numerous general-purpose I/O pins, peripheral functions such as timers and UARTs and is one of the first devices to provide an embedded Voice CODEC. This device is also ideal for low power applications.

The original MeshConnect module delivers excellent performance at a surprisingly low cost. The module's +6dBm output power means better range, more reliable transmission and fewer nodes in your network. It also makes these modules ideal for applications where cost and power constraints do not allow for external power amplifiers or peripheral range extension components.

The MeshConnect Extended Range module adds a power amplifier (PA) and low noise amplifier (LNA) to increase range to over two miles - plus more reliable transmission and fewer nodes in your network. It is especially useful for open outdoor applications where the nodes are physically far apart, or for indoor use where the nodes have to operate in a noisy RF environment. The Extended Range Module's outstanding +123 dB budget link ensures high quality connection even in such harsh environments.

CEL MeshConnect™ Module Series



- 96 kB FLASH Memory
- 8 kB SRAM
- 8051 MCU core
- up to 22 GPIO Pins
- SPI (Master/Slave) + UARTs
- I²S/PCM Interface with two 128-byte FIFOs
- μ -law/a-law/ADPCM Voice Codec
- 4-channel 8-bit ADC

FEATURES

- High RF performance:
 - Up to 123 dB RF Link Budget
 - RX Sensitivity: -97 dBm and -103.0 dBm
 - RF TX Power: +6 dBm and +20 dBm
- Scalable Data Rate: 250 kbps, 500 kbps and 1 Mbps
- Small footprint: 1" x 1.413" (25.4 mm x 35.9 mm)
- Voice Codec Support: μ -law/a-law/ADPCM
- 4 Level Power Management Scheme w/ Deep Sleep Mode (0.3 μ A)
- Integrated PCB trace antenna
- 16 RF channels
- Range:
 - ZICM2410P0: 2000+ feet (609+ meters)
 - ZICM2410P2: 16000+ feet (4876+ meters)
- AES 128-bit encryption
- Extended software support:
 - SNAP™
 - SMAC, MAC
 - Audio
- FCC, CE and IC certifications
- ROHS compliant

APPLICATIONS

Industrial Controls

- Food processing controls
- Traffic Management
- Sensor Networks
- Asset Management
- Barcode reader
- Patient Monitoring
- Glucose monitor

Home & Building Automation

- Security
- HVAC control
- Lighting control
- Thermostats

ORDERING INFORMATION

Part Number	Order Number	Description	Mins/Mults
MeshConnect™ Module	ZICM2410P0-1	+6 dBm Output power, PCB Trace antenna	140/140
	ZICM2410P0-1-SN	+6 dBm Output power, PCB Trace antenna, SNAP OS with MAC address	140/140
	ZICM2410P0-1C	+6 dBm Output power, with u.FL Connector for external antenna	140/140
	ZICM2410P0-1C-SN	+6 dBm Output power, with u.FL Connector for external antenna, SNAP OS with MAC address	140/140
	ZICM2410P0-KIT2-1	+6 dBm Engineering Development Kit	1/1
MeshConnect™ Extended Range Module	ZICM2410P2-2	+20 dBm Output power, PCB Trace antenna	140/140
	ZICM2410P2-2-SN	+20 dBm Output power, PCB Trace antenna, SNAP OS with MAC address	140/140
	ZICM2410P2-2C	+20 dBm Output power, with u.FL Connector for external antenna	140/140
	ZICM2410P2-2C-SN	+20 dBm Output power, with u.FL Connector for external antenna, SNAP OS with MAC address	140/140
	ZICM2410P2-KIT1-1	Evaluation board for +20 dBm module	1/1

The information in this document is subject to change without notice, please confirm data is current

Document No: 0007-00-07-00-000 (Issue E)

Date Published: June 14, 2012

MODULE BLOCK DIAGRAM

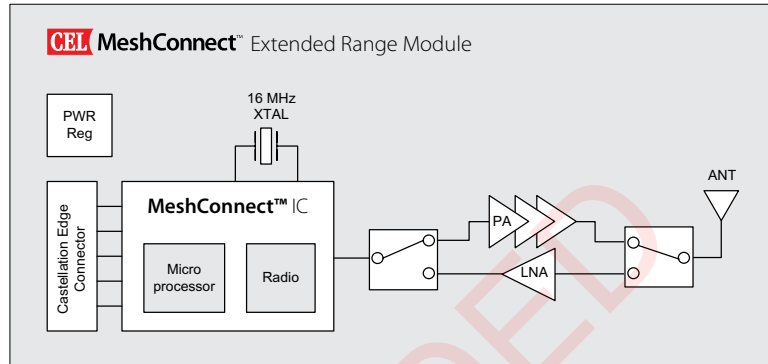
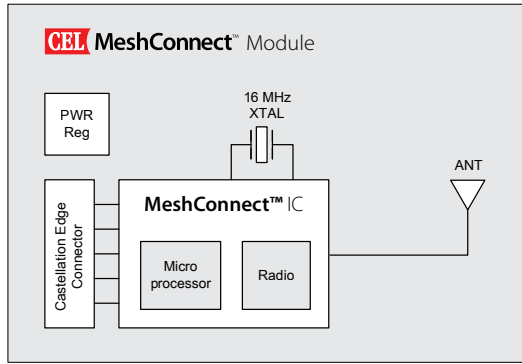

DEVELOPMENT KIT

CEL's MeshConnect Development Kit assist users in both evaluation and development. As a stand-alone radio system, the kit allows users to place the modules in to the target environment and evaluate performance on-site. The MeshConnect Development Kit also serves as an invaluable aid in application development. Through the many interface headers on the board, the user has access to all the MeshConnect module pins enabling easy connection to target systems for application development. The key components of the MeshConnect Development Kits are the CEL's MeshConnect radio module and the interface board.

The MeshConnect module contains the CEL transceiver IC, Crystals, Power Regulator and an integrated PCB antenna or connector for an external antenna (optional). The interface board features a serial communication interface, a power management module, and peripherals such as potentiometers, LEDs, and GPIO headers.

For more detail information regarding MeshConnect Development Kits, refer to the respective development kit user guides documents. (Available at CEL's website <http://www.cel.com>)

Order Number	Description
ZICM2410P0-KIT2-1	+6dBm Engineering Development Kit
ZICM2410P2-KIT1-1	Evaluation board for +20 dBm module

MeshConnect™ Module Development Kit



Kit Contents:

- Evaluation Boards w/Module (3)
- AA Batteries (4)
- USB Cables (1)
- Universal AC/DC Power Supply (2)
- Jumpers (10)
- Software & Technical Information CD (2)
- USB/WNA w/Cable (1)

MeshConnect™ Extended Range Module Development Kit



Kit Contents:

- Evaluation Boards w/Module (1)
- Jumpers (2)
- USB Cables (1)
- Software & Technical Information CD (2)

TABLE OF CONTENTS

Introduction and Overview

Description.....	1
Features.....	1
Applications.....	1
Ordering Information.....	1
Module Block Diagram.....	2
Development Kit.....	2

System Level Function

Transceiver IC.....	4
Modes of Operation (TX, RX, Sleep).....	5
Power Amplifier.....	6
Interface.....	6
Software Tools.....	6

Electrical Specification

Absolute Maximum Ratings.....	8
Recommended (Operating Condition).....	8
DC Characteristics.....	8
RF Characteristics.....	8

Pin Signal & Interfaces

Pin Signals I/O Configuration.....	9
I/O Pin Assignment.....	9
Module Dimensions.....	11

Processing

13

Agency Certifications

14

Shipment, Storage & Handling

15

References & Revision History

16

NOT RECOMMENDED FOR NEW DESIGN

TRANSCEIVER IC

A true monolithic solution, the MeshConnect IC incorporates the RF transceiver with baseband modem, a hardwired MAC, and an embedded 8051 microcontroller, offering an excellent low cost high performance solution for all IEEE 802.15.4 applications.

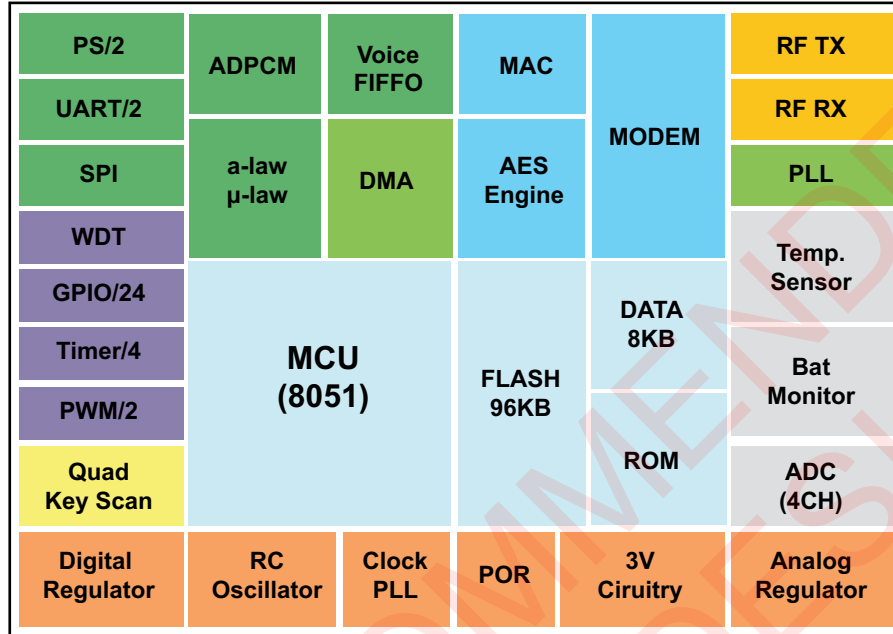

With an industry best +6 dBm output power, the MeshConnect IC will support a wide variety of applications without the need for external amplification. Combined with a highly sensitive -97 dBm receiver the MeshConnect IC leads the industry with 103 dB link budget.

In addition to excellent RF performance at 250 kbps data rates, the IC adds high speed modes, Turbo (500 kbps) and Premium (1 Mbps), for networks looking for increased throughput. The device provides numerous general-purpose I/O pins, peripheral functions such as timers and UARTs and is one of the first devices to provide an embedded Voice CODEC.

CEL provides its customers with the IEEE 802.15.4 stack as part of the software library. Also available are the hardware & software tools required to develop custom applications.

The combination of industry leading link budget, high speed RF, and integrate voice CODEC make the IC a truly distinct single chip solution.

The Extended Range module adds both an PA and LNA to maximize RF performance. The PA enable the Extended Range module to output up to +20 dBm transmit power. In the receive path the addition of the LNA boosts the already sensitive receiver up to -103 dBm. The Extended Range link budget boasts a very robust 123 dB enabling a line of sight range over 3 miles.

ANTENNA

CEL's MeshConnect modules include an integrated Printed Circuit Board (PCB) trace antenna. An optional u.FL connector can be specified, providing connection to a 50-ohm external antenna of the user's choice. See Ordering Information on page 1.

The PCB antenna employs an F-Antenna topology that is compact and supports an omni-directional radiation pattern. To maximize antenna efficiency, an adequate ground plane must be provided on the host PCB. Correctly positioned, the ground plane on the host PCB will contribute significantly to the antenna performance (it should not be directly under the F-Antenna). The position of the module on the host board and overall design of the product enclosure contribute to antenna performance. Poor design affects radiation patterns and can result in reflection, diffraction, and/or scattering of the transmitted signal.

Here are some design guidelines to help ensure antenna performance:

- Never place the ground plane or route copper traces directly underneath the antenna portion of the module.
- Never place the antenna close to metallic objects.
- In the overall design, ensure that wiring and other components are not placed near the antenna.
- Do not place the antenna in a metallic or metalized plastic enclosure.
- Keep plastic enclosures 1 cm or more from the antenna in any direction.

For optimum antenna performance, the MeshConnect modules should be mounted with the PCB trace antenna overhanging the edge of the host board. To further improve performance, a ground plane may be placed on the host board under the module, up to the antenna. The installation of an uninterrupted ground plane on a layer directly beneath the module will also allow you to run traces under this layer. CEL can provide assistance with your PCB layout.

MODES OF OPERATION

There are three power down modes in the IC. Each mode can be set using the PDMODE [1:0] bits in the PDCON register and power down modes can be started by setting the PDSTART bit to 1. Each mode has a different current consumption and wake-up sources, please refer to the IC datasheet for further information on the available power down modes. Table 8 describes the three power down modes.

Table 8 – Power Down Modes

PDMODE [1:0]	Description	Wake-Up Source	Regulator for Digital block
0	Active (Normal Operation)	-	-
1	PM1 mode	Hardware Reset, Sleep Timer interrupt, External interrupt	ON
2	PM2 mode	Hardware Reset, Sleep Timer interrupt, External interrupt	OFF (After wake-up, register configuration is required)
3	PM3 mode	Hardware Reset, External interrupt	OFF (After wake-up, register configuration is required)

POWER AMPLIFIER

The ZICM2410P0 MeshConnect module does not incorporate an external Power Amplifier and therefore the RF output port is connected directly (through matching components) to the RF antenna. As CEL's IC IEEE 802.15.4 transceiver already offers the industry's best link budget at 103 dB, even without an external PA the MeshConnect can maintain wireless connection over long distance (2,000 ft line-of-sight).

The Extended Range module adds both an PA and LNA to maximize RF performance. The PA enable the Extended Range module to output up to +20 dBm transmit power. In the receive path the addition of the LNA boosts the already sensitive receiver up to -103 dBm. The Extended Range link budget boasts a very robust 123 dB enabling a line of sight range over 3 miles.

INTERFACE

The MeshConnect has all major communication interfaces routed from the IC to the module edge connectors:

- UART1 & UART 2
- I²S
- SPI

VOICE CODEC

The MeshConnect IC includes three voice codec algorithms: μ -law, a-law and ADPCM.

The μ -law algorithm is a companding algorithm primarily used in the digital telecommunication systems of North America and Japan. As with other companding algorithms, its purpose is to reduce the dynamic range of an audio signal. In the analog domain this can increase the signal-to-noise ratio (SNR) achieved during transmission and in the digital domain, it can reduce the quantization error (hence increasing signal to quantization noise ratio). These SNR improvements can be traded for reduced bandwidth and equivalent SNR instead. The a-law algorithm is a standard companding algorithm used in European digital communications systems to optimize/modify the dynamic range of an analog signal for digitizing.

The a-law algorithm provides a slightly larger dynamic range than the μ -law at the cost of worse proportional distortion for small signals.

Adaptive DPCM (ADPCM) is a variant of DPCM [Differential (or Delta) pulse-code modulation] that varies the size of the quantization step, allowing further reduction of the required bandwidth for a given signal-to-noise ratio. DPCM encodes the PCM values as differences between the current and the previous value. For audio applications this type of encoding reduces the number of bits required per sample by about 25% compared to PCM.

SOFTWARE TOOLS

CEL offers complete SW tools for MeshConnect that customers need to create their application.

DEVICE PROGRAMMER

- Device Programmer is used to program the application firmware to the on-chip Flash program memory of the IC device.
- Device Programmer supports:
 - **ISP Mode:** Download the firmware from the host PC via serial communication through the IC's UART1 interface.
 - The evaluation boards utilize a USB -> Serial converter.
 - **OTA Mode:** Download the firmware from the host PC using wireless communication (Over-The-Air).
 - This requires two nodes, the host (connected to a PC) and the target device to be programmed.

Device Programmer can read/write hardware information (i.e. IEEE Address, Channel #, etc) directly via the aforementioned communication modes.

SOFTWARE TOOLS (Continued)**PACKET ANALYZER AND WIRELESS NETWORK ANALYZER**

- Packet Analyzer monitors traffic over a wireless network channel by capturing RF packet data in real-time.
- Packet Analyzer requires the Wireless Network Analyzer to “sniff” the RF packets.
- Packet Analyzer also includes diagnostic tools:
 - Energy Scan: Evaluates the received signal power within the bandwidth of an IEEE 802.15.4 channel yielding available channels.
 - Active Scan: Scanning for active Coordinators and Routers broadcasting a Beacon frame.
- Can be used in conjunction with any IEEE 802.15.4 or network.

KEIL 8051 DEVELOPMENT TOOLS (Evaluation version provided in development kit).

- Supports all 8051 derivatives and variants.
- Easy-to-Use μ Vision Integrated Development Environment (IDE) supports the complete development cycle.
- Supports memory banking for CODE and variables beyond the 64 kbyte threshold.

Numerous optimization levels yield the ability to place more features into less memory providing the utmost code density.

ABSOLUTE MAXIMUM RATINGS

Description	MeshConnect™ Module		MeshConnect™ Extended Range Module		Unit
	Min	Max	Min	Max	
Power Supply Voltage (Vcc)	-0.3	3.3	-0.3	3.3	VDC
Voltage on any digital pin	-0.3	3.3	-0.3	3.3	VDC
Input RF Level		10		-6	dBm
Storage Temperature	-55	125	-55	125	°C
Reflow Soldering Temperature		250		250	°C

Note: Exceeding the maximum ratings may cause permanent damage to the module or devices.

RECOMMENDED (OPERATING CONDITIONS)

Description	MeshConnect™ Module MeshConnect™ Extended Range Module			Unit
	Min	Typ	Max	
Operating ambient temperature range, T _A	-40	25	85	°C
Operating Supply Voltage	2.1	3.0	3.3	VDC
Input Frequency	2.405		2.48	GHz

DC CHARACTERISTICS (@ 25°C, VCC = 3.0V unless otherwise noted)

Description	MeshConnect™ Module			MeshConnect™ Extended Range Module			Unit
	Min	Typ	Max	Min	Typ	Max	
Vcc Supply (Vcc)	2.1		3.3	2.1		3.3	VDC
Rx mode Current (Vcc=3.0V)		35	38		38	42	mA
Tx mode Current (Vcc=3.0V, Pout Max)		44	48		200		mA
Tx mode Current (Vcc=2.1V, Pout Max)		44	48		295		mA
Tx mode Current (Vcc=3.0V, 0 dBm)		31			75		mA
Sleep Mode (Deep) Current		1			1		µA

RF CHARACTERISTICS (@ 25°C, VCC = 3.0V unless otherwise noted)

Description	MeshConnect™ Module			MeshConnect™ Extended Range Module			Unit
	Min	Typ	Max	Min	Typ	Max	
Frequency Band (16–5MHz wide channels)	2.405		2.480	2.405		2.480	GHz
Rx Sensitivity for 1%PER		-97	-85		-103.0	-85	dBm
Saturation (maximum input level)		5			-11		dBm
Tx Output Power (Vcc=3.0V)	4.5	6.0			20		dBm
TX Output Power (Vcc=2.1V)	4.5	6.0			19.6		dBm
Error Vector Magnitude		17	35		15	35	%
Adjacent Channel Rejection +/- 5 MHz	35	47		35	47		dB
+/- 10 MHz	35	51		35	51		
Frequency Error Tolerance	-96.2		96.2	-96.2		96.2	kHz
Output Power Control Range		55			55		dB
Over the Air Data Rate		250	1000		250	1000	kbps
Harmonics (2 nd & 3 rd)			-41.2			-41.2	dBm/MHz

PIN SIGNALS I/O PORT CONFIGURATION

MeshConnect module has 56 edge I/O interfaces for connection to the user’s host board. The MeshConnect Module Dimensions shows the layout of the 56 edge castellations.

MeshConnect I/O PIN ASSIGNMENTS

Pin #	MeshConnect™ Module	MeshConnect™ Extended Range Module	Type	Description	Functionality	IC Pin #
1	GND	GND	GND-RF	Ground	Ground	N/A
2	GND	GND	GND-RF	Ground	Ground	N/A
3	MS1	NC	static control line	Mode Select, Bit #1. Active Low Internal Voltage Regulator Enable: 0: Internal Voltage Regulator Enabled 1: Internal Voltage Regulator Disabled, Supply Analog and Digital Supply Voltages Externally	No connect	14
4	GND	GND	GND-RF	Ground	Ground	N/A
5	GND	NC	GND	GND	Ground	13
6	NC	NC	NC	no connect	No connect	N/A
7	GND	GND	GND-Logic	Ground	Ground	49
8	GND	GND	GND-Logic	Ground	Ground	49
9	GND	GND	GND-Logic	Ground	Ground	49
10	GND	GND	GND-Logic	Ground	Ground	49
11	GND	GND	GND-Logic	Ground	Ground	49
12	ACH0	ACH0	Analog Input	1.5V Level Analog ADC0 Input	ADC input	8
13	ACH1	ACH1	Analog Input	1.5V Level Analog ADC1 Input	ADC input	9
14	ACH2	ACH2	Analog Input	1.5V Level Analog ADC2 Input	ADC input	10
15	ACH3	ACH3	Analog Input	1.5V Level Analog ADC3 Input	ADC input	11
16	P1_7	NC	digital I/O	Port P1.7	Digital I/O	20
17	P1_6	NC	digital I/O	Port P1.6	Digital I/O	21
18	P1_4	P1_4	digital I/O	Port P1.4/ QUADZB/ Sleep Timer OSC Buffer Input	digital I/O or dedicated function port	22
19	P1_3	P1_3	digital I/O	Port P1.3/ QUADZA/ Sleep Timer OSC Buffer Output/ RTCLKOUT	digital I/O or dedicated function port	23
20	GND	GND	GND-Logic	Ground	Ground	49
21	GND	GND	GND-Logic	Ground	Ground	49
22	GND	GND	GND-Logic	Ground	Ground	49
23	P1_1	P1_1	digital I/O	Port P1.1/ TXD1	digital I/O or dedicated function port	24
24	VCC_3V	VCC_3V	Power	3.0V Power supply for Analog Internal Voltage Regulator	Power Input	7
25	P1_0	P1_0	digital I/O	Port P1.0/ RXD1	digital I/O or dedicated function port	26
26	P3_7	P3_7	digital I/O	Port P3.7/ 12mA Drive capability/ PWM3/ CTS1/ SPICSN	digital I/O with high current capability	27
27	P3_6	P3_6	digital I/O	Port P3.6/ 12mA Drive capability/ PWM2/ RTS1/ SPICLK	digital I/O with high current capability	28

Note:

1. Digital 1.5V regulator output. Sources little current. If it is used by the host board, care must be taken to ensure noise is not introduced as it could degrade RF performance.

MeshConnect I/O PIN ASSIGNMENTS (Continued)

Pin #	MeshConnect™ Module	MeshConnect™ Extended Range Module	Type	Description	Functionality	IC Pin #
28	P3_5	P3_5	digital I/O	Port P3.5/T1/CTS0/QUADYB/SPIDO	digital I/O or dedicated function port	29
29	P3_4	P3_4	digital I/O	Port P3.4/T0/RTS0/QUADYA/SPIDI	digital I/O or dedicated function port	30
30	GND	GND	GND-Logic	Ground	Ground	49
31	P3_3	P3_3	digital I/O	Port P3.3/INT1 (active low)	digital I/O or dedicated function port	31
32	P3_2	P3_2	digital I/O	Port P3.2/INT0 (active low)	digital I/O or dedicated function port	32
33	GND	GND	GND-Logic	Ground	Ground	49
34	P3_1	P3_1	digital I/O	Port P3.1/TXD0/QUADXB	digital I/O or dedicated function port	33
35	P3_0	P3_0	digital I/O	Port P3.0/RXD0/QUADXA	digital I/O or dedicated function port	35
36	GND	GND	GND-Logic	Ground	Ground	49
37	P0_7	P0_7	digital I/O	GPIO8051 Port P0.7/I2STX_MCLK	digital I/O	36
38	P0_6	P0_6	digital I/O	GPIO8051 Port P0.6/I2STX_BCLK	digital I/O	37
39	P0_5	P0_5	digital I/O	GPIO8051 Port P0.5/I2STX_LRCLK	digital I/O	38
40	P0_4	P0_4	digital I/O	GPIO8051 Port P0.4/I2STX_DO	digital I/O	39
41	P0_3	P0_3	digital I/O	GPIO8051 Port P0.3/I2SRX_MCLK	digital I/O	40
42	P0_2	P0_2	digital I/O	GPIO8051 Port P0.2/I2SRX_BCLK	digital I/O	41
43	P0_1	P0_1	digital I/O	GPIO8051 Port P0.1/I2SRX_LRCK	digital I/O	42
44	P0_0	P0_0	digital I/O	GPIO8051 Port P0.0/I2SRX_DI	digital I/O	43
45	DVDD_1_5 ⁽¹⁾	NC	Power	Output of Digital Internal Voltage Regulator (1.5V) / 1.5V Power supply for Digital Core (input mode @ No REG)	Selected as Internal Regulator output or Regulated Voltage supply Input	19
46	ISP	ISP	Digital Input	Mode Select, Bit #2. Active High In-System Programming (ISP) Input: 0: Normal Mode 1: ISP Mode	Programming	15
47	RESET	RESET	Control	Reset (Active Low)	Hardware Reset	17
48	AVDD_1_5 ⁽¹⁾	NC	Power	Output of Analog Internal Voltage Regulator (1.5V) / 1.5V Power supply for Mixer, VGA, and LPF (input mode @ No REG)	Selected as Internal Regulator output or Regulated Voltage supply Input	6
49	GND	GND	GND-Logic	Ground	Ground	49
50	GND	GND	GND-Logic	Ground	Ground	49
51	GND	GND	GND-Logic	Ground	Ground	49
52	GND	GND	GND-Logic	Ground	Ground	49
53	GND	GND	GND-Logic	Ground	Ground	49
54	NC	NC	NC	No Connect	No connect	N/A
55	GND	GND	GND-RF	Ground	Ground	N/A
56	GND	GND	GND-RF	Ground	Ground	N/A

Note:

1. Digital 1.5V regulator output. Sources little current. If it is used by the host board, care must be taken to ensure noise is not introduced as it could degrade RF performance.

MODULE DIMENSIONS

MeshConnect™ Module / **MeshConnect™** Extended Range Module
w/U.FL Connector for external antenna

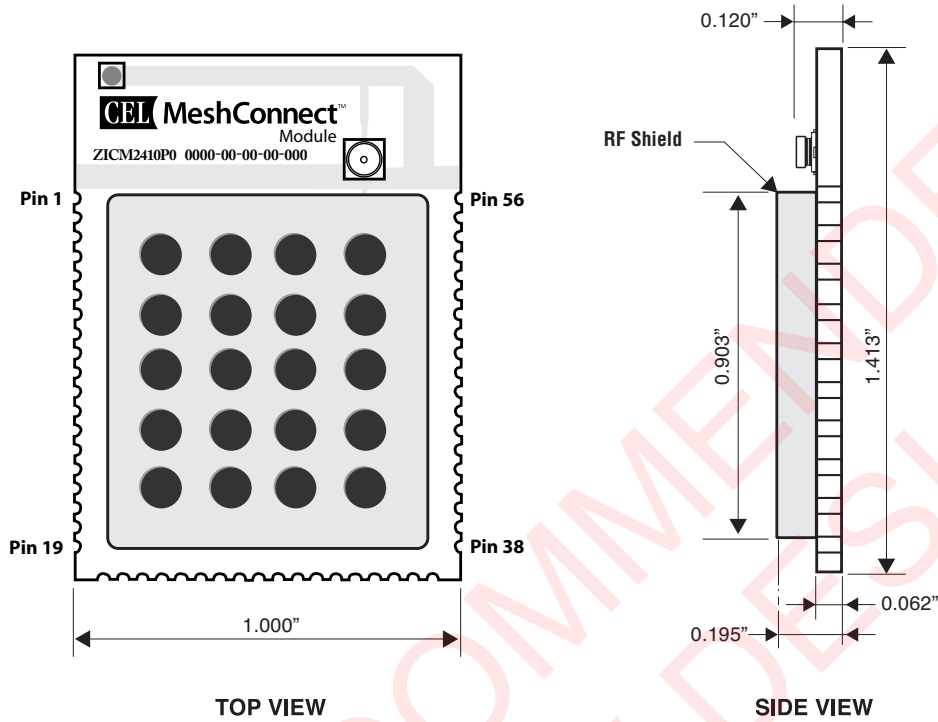

MeshConnect™ Module / **MeshConnect™** Extended Range Module
w/PCB Trace Antenna

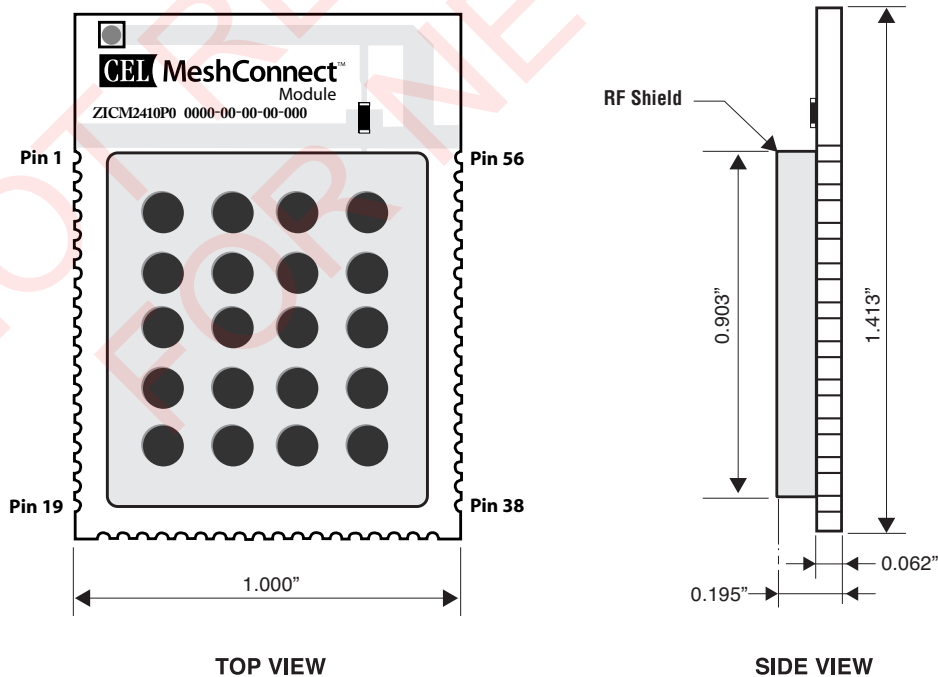

For layout recommendation for optimum antenna performance, refer to Antenna section in this document.

MODULE LAND FOOTPRINT

Note: Unless otherwise specified. Dimensions are in Inches [mm].

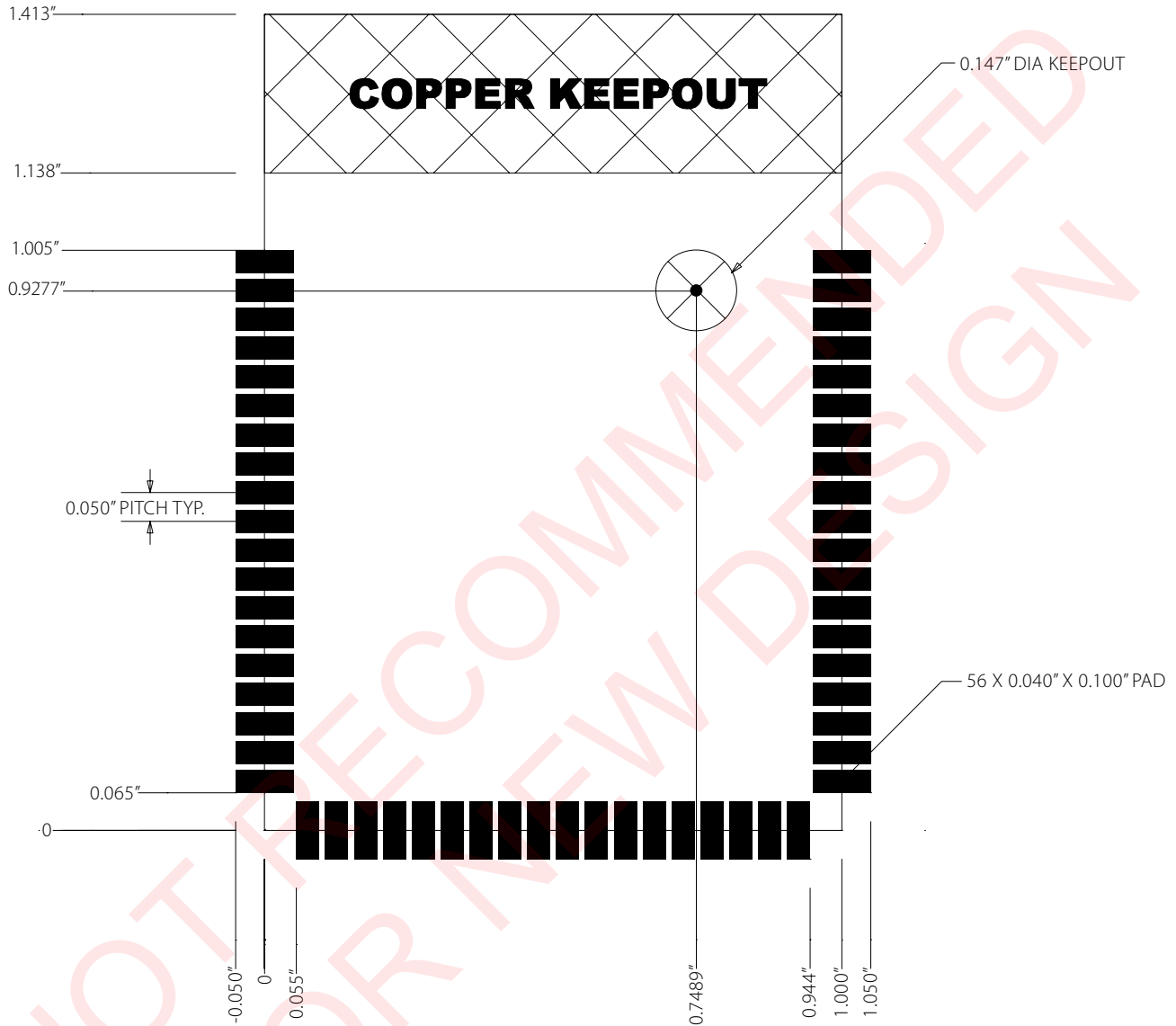

PROCESSING

Recommended Reflow Profile

Parameters Values	
Ramp up rate (from Tsoakmax to Tpeak)	3°/sec max
Minimum Soak Temperature	150°C
Maximum Soak Temperature	200°C
Soak Time	60-120 sec
TLiquidus	217°C
Time above TL	60-150 sec
Tpeak	250°C
Time within 5° of Tpeak	20-30 sec
Time from 25° to Tpeak	8 min max
Ramp down rate	6°C/sec max

Achieve the brightest possible solder fillets with a good shape and low contact angle.

Pb-Free Soldering Paste

Use of “No Clean” soldering paste is strongly recommended, as it does not require cleaning after the soldering process.

Note: The quality of solder joints on the castellations (‘half vias’) where they contact the host board should meet the appropriate IPC Specification. See **IPC-A-610** “Acceptability of Electronic Assemblies, section 8.2.4 Castellated Terminations.”

Cleaning

In general, cleaning the populated modules is strongly discouraged. Residuals under the module cannot be easily removed with any cleaning process.

- Cleaning with water can lead to capillary effects where water is absorbed into the gap between the host board and the module. The combination of soldering flux residuals and encapsulated water could lead to short circuits between neighboring pads. Water could also damage any stickers or labels.
- Cleaning with alcohol or a similar organic solvent will likely flood soldering flux residuals into the two housings, which is not accessible for post-washing inspection. The solvent could also damage any stickers or labels.
- Ultrasonic cleaning could damage the module permanently.

The best approach is to consider using a “no clean” soldering paste and eliminate the post-soldering cleaning step.

Optical Inspection

After soldering the Module to the host board, consider optical inspection to check the following:

- Proper alignment and centering of the module over the pads.
- Proper solder joints on all pads.
- Excessive solder or contacts to neighboring pads, or vias.

Repeating Reflow Soldering

Only a single reflow soldering process is encouraged for host boards.

Wave Soldering

If a wave soldering process is required on the host boards due to the presence of leaded components, only a single wave soldering process is encouraged.

PROCESSING *(Continued)*

Hand Soldering

Hand soldering is possible. Use a soldering iron temperature setting equivalent to 350°C, follow IPC recommendations/ reference document IPC-7711.

Rework

The MeshConnect Module can be unsoldered from the host board. Use of a hot air rework tool and hot plate for pre-heating from underneath is recommended. Avoid overheating.

Warning Never attempt a rework on the module itself, e.g. replacing individual components. Such actions will terminate warranty coverage.

Additional Grounding

Attempts to improve module or system grounding by soldering braids, wires, or cables onto the module RF shield cover is done at the customer's own risk. The numerous ground pins at the module perimeter should be sufficient for optimum immunity to external RF interference.

AGENCY CERTIFICATIONS

FCC Compliance Statement (Part 15.19) Section 7.15 of RSS-GEN

This device complies with Part 15 of the FCC Rules. Operation is subject to the following two conditions:

1. This device may not cause harmful interference.
2. This device must accept any interference received, including interference that may cause undesired operation.

Warning (Part 15.21)

Changes or modifications not expressly approved by CEL could void the user's authority to operate the equipment.

20 cm Separation Distance

To comply with FCC/IC RF exposure limits for general population / uncontrolled exposure, the antenna(s) used for this transmitter must be installed to provide a separation distance of at least 20 cm from all persons and must not be co-located or operating in conjunction with any other antenna or transmitter.

OEM Responsibility to the FCC Rules and Regulations

The MeshConnect Module has been certified per FCC Part 15 rules for integration into products without further testing or certification. To fulfill the FCC certification requirements, the OEM of the MeshConnect Module must ensure that the information provided on the MeshConnect Label is placed on the outside of the final product. The MeshConnect Module is labeled with its own FCC ID Number. If the FCC ID is not visible when the module is installed inside another device, then the outside of the device into which the module is installed must also display a label referring to the enclosed module. This exterior label can use wording such as the following: "Contains Transmitter Module FCC ID: W7Z-ICP0" or "Contains FCC ID: W7Z-ICP0"

The OEM of the MeshConnect Module must only use the approved antenna, (PCB Trace Antenna) that has been certified with this module. The OEM of the MeshConnect Module must test their final product configuration to comply with Unintentional Radiator Limits before declaring FCC compliance per Part 15 of the FCC rules.

AGENCY CERTIFICATIONS *(Continued)*

IC Certification — Industry Canada Statement

The term "IC" before the certification / registration number only signifies that the Industry Canada technical specifications were met.

Section 14 of RSS-210

The installer of this radio equipment must ensure that the antenna is located or pointed such that it does not emit RF field in excess of Health Canada limits for the general population. Consult Safety Code 6, obtainable from Health Canada's website: <http://www.hc-sc.gc.ca/ewh-semt/pubs/radiation/99ehd-dhm237/index-eng.php>

CE Certification — Europe

The MeshConnect RF module has been tested and certified for use in the European Union.

OEM Responsibility to the European Union Compliance Rules

If the MeshConnect module is to be incorporated into a product, the OEM must verify compliance of the final product to the European Harmonized EMC and Low-Voltage / Safety Standards. A Declaration of Conformity must be issued for each of these standards and kept on file as described in Annex II of the R&TTE Directive.

The manufacturer must maintain the user's guide and adhere to the settings described in the manual for maintaining European Union Compliance. If any of the specifications are exceeded in the final product, the OEM is required to make a submission to the notified body for compliance testing.

OEM Labeling Requirements

The 'CE' mark must be placed on the OEM product in a visible location.

The CE mark shall consist of the initials "CE" with the following form:

- If the CE marking is reduced or enlarged, the proportions given in the above graduated drawing must be adhered to.
- The CE mark must be a minimum of 5mm in height
- The CE marking must be affixed visibly, legibly, and indelibly. Since the 2400 - 2483.5 MHz band is not harmonized by a few countries throughout Europe, the Restriction sign must be placed to the right of the "CE" marking as shown in the picture



SHIPMENT, HANDLING, AND STORAGE

Shipment

The MeshConnect Modules are delivered in trays of 28.

Handling

The MeshConnect Modules are designed and packaged to be processed in an automated assembly line.

Warning The MeshConnect Modules contain highly sensitive electronic circuitry. Handling without proper ESD protection may destroy or damage the module permanently.

Warning According to JEDEC ISP, the MeshConnect Modules are moisture-sensitive devices. Appropriate handling instructions and precautions are summarized in Section 2.1. Read carefully to prevent permanent damage due to moisture intake.

Moisture Sensitivity Level (MSL)

MSL3, per J-STD-033

Storage

Storage/shelf life in sealed bags is 12 months at <40°C and <90% relative humidity.

REFERENCES & REVISION HISTORY

Previous Versions	Changes to Current Version	Page(s)
0007-00-07-00-000 (Issue A) February 05, 2009	Initial preliminary datasheet.	N/A
0007-00-07-00-000 (Issue B) June 11, 2009	Updated Development Kit and Agency Certification	2, 14, 15
0007-00-07-00-000 (Issue C) October 6, 2009	Added New MeshConnect Extended Range Module	All
0007-00-07-00-000 (Issue C) January 29, 2010	Removed "Preliminary" from datasheet and "Pending" from Agency Certification	All
0007-00-07-00-000 (Issue C) April 7, 2010	Added SNAP enabled modules to Ordering Information, updated module land footprint	1
0007-00-07-00-000 (Issue D) December 22, 2010	MeshConnect Extend Range Module part number change to -2	All
0007-00-07-00-000 (Issue D) February 8, 2011	MeshConnect Extend Range Module W/connector part number change to -1	1
0007-00-07-00-000 (Issue E) June 14, 2012	Changed ZICM2410P2-1C part number to -2C, updated Coaxial Keepout diagram	1, 12

Disclaimer

- The information in this document is current as of the published date. The information is subject to change without notice. For actual design-in, refer to the latest publications of CEL data sheets or data books, etc., for the most up-to-date specifications of CEL products. Not all products and/or types are available in every country. Please check with an CEL sales representative for availability and additional information.
- No part of this document may be copied or reproduced in any form or by any means without the prior written consent of CEL. CEL assumes no responsibility for any errors that may appear in this document.
- CEL does not assume any liability for infringement of patents, copyrights or other intellectual property rights of third parties by or arising from the use of CEL products listed in this document or any other liability arising from the use of such products. No license, express, implied or otherwise, is granted under any patents, copyrights or other intellectual property rights of CEL or others.
- Descriptions of circuits, software and other related information in this document are provided for illustrative purposes in semiconductor product operation and application examples. The incorporation of these circuits, software and information in the design of a customer's equipment shall be done under the full responsibility of the customer. CEL assumes no responsibility for any losses incurred by customers or third parties arising from the use of these circuits, software and information.
- While CEL endeavors to enhance the quality, reliability and safety of CEL products, customers agree and acknowledge that the possibility of defects thereof cannot be eliminated entirely. To minimize risks of damage to property or injury (including death) to persons arising from defects in CEL products, customers must incorporate sufficient safety measures in their design, such as redundancy, fire-containment and anti-failure features.