

# Common Mode Chokes – BU Series

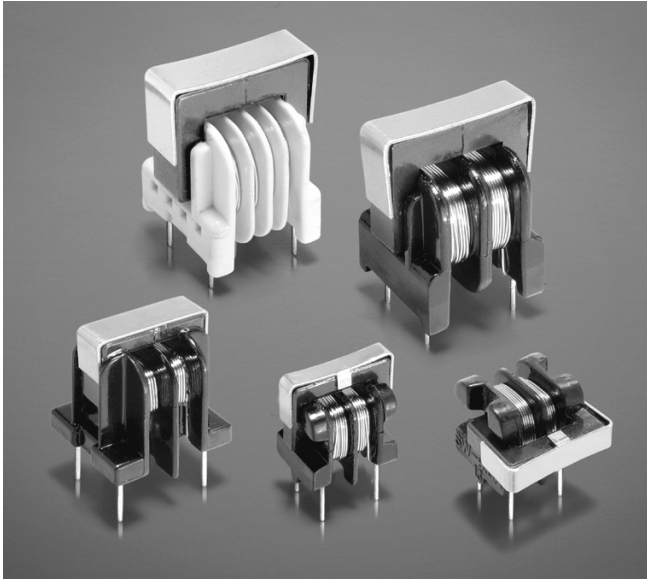

These low cost, high performance choke coils are designed to virtually eliminate line conducted common mode noise.

The BU9S and BU9HS families are ideal for signal line applications; the others can be used in switching power supplies and power supply circuits. All provide significant attenuation of common mode noise across a broad range of frequencies.

For height-restricted applications, the BU9 and BU9S filters are available in a horizontal configuration, which reduces their height to under half an inch (12.5 mm).

For free evaluation samples, contact Coilcraft or request them on-line at [www.coilcraft.com](http://www.coilcraft.com).

**Core material** Ferrite

**Terminations** RoHS compliant tin-silver over copper. Other terminations available at additional cost.

**Weight** BU9: 3.1 – 4.1 g  
 BU9H: 3.1 – 4.1 g  
 BU9HS: 3.1 – 3.8 g  
 BU9S: 3.1 – 3.8 g  
 BU10: 6.3 – 6.9 g  
 BU15: 14.6 – 16.1 g  
 BU16: 15.1 – 18.0 g

**Ambient temperature** –40°C to +125°C

**Storage temperature** Component: –40°C to +125°C.  
 Tray packaging: –40°C to +80°C

**Moisture Sensitivity Level (MSL)** 1 (unlimited floor life at <30°C / 85% relative humidity)

**Failures in Time (FIT) / Mean Time Between Failures (MTBF)**  
 38 per billion hours / 26,315,789 hours, calculated per Telcordia SR-332

**Packaging** BU9: 100 per tray  
 BU9H: 100 per tray  
 BU9HS: 100 per tray  
 BU9S: 100 per tray  
 BU10: 100 per tray  
 BU15: 80 per tray  
 BU16: 80 per tray

**PCB washing** Tested to MIL-STD-202 Method 215 plus an additional aqueous wash. See [Doc787\\_PCB\\_Washing.pdf](#).



[www.coilcraft.com](http://www.coilcraft.com)

**US** +1-847-639-6400 [sales@coilcraft.com](mailto:sales@coilcraft.com)  
**UK** +44-1236-730595 [sales@coilcraft-europe.com](mailto:sales@coilcraft-europe.com)  
**Taiwan** +886-2-2264 3646 [sales@coilcraft.com.tw](mailto:sales@coilcraft.com.tw)  
**China** +86-21-6218 8074 [sales@coilcraft.com.cn](mailto:sales@coilcraft.com.cn)  
**Singapore** + 65-6484 8412 [sales@coilcraft.com.sg](mailto:sales@coilcraft.com.sg)

Document 260-1 Revised 09/12/17

© Coilcraft Inc. 2017

This product may not be used in medical or high risk applications without prior Coilcraft approval. Specification subject to change without notice. Please check web site for latest information.



# Common Mode Chokes - BU9S, BU9HS Series

Part number	Common mode peak impedance (kOhms)	Inductance <sup>1</sup> min (mH)	DCR <sup>2</sup> (Ohms)	Isolation <sup>3</sup> (Vrms)	Current max (A)
BU9S-153R15BL	105.7 @ 200 kHz	15.0	5.0	1000	0.15
BU9S-7020R3BL	59.8 @ 370 kHz	7.0	2.5	1000	0.30
BU9HS-153R15BL	146.5 @ 220 kHz	15.0	5.0	1000	0.15
BU9HS-7020R3BL	61.9 @ 380 kHz	7.0	2.5	1000	0.30

1. Inductance tested at 1 kHz, 1 Vrms, 0 Adc on an Agilent/HP 4284A LCR-meter or equivalent.
2. DCR is per winding
3. Interwinding isolation (hipot) tested for one minute.
4. Electrical specifications at 25°C.

## BU9S

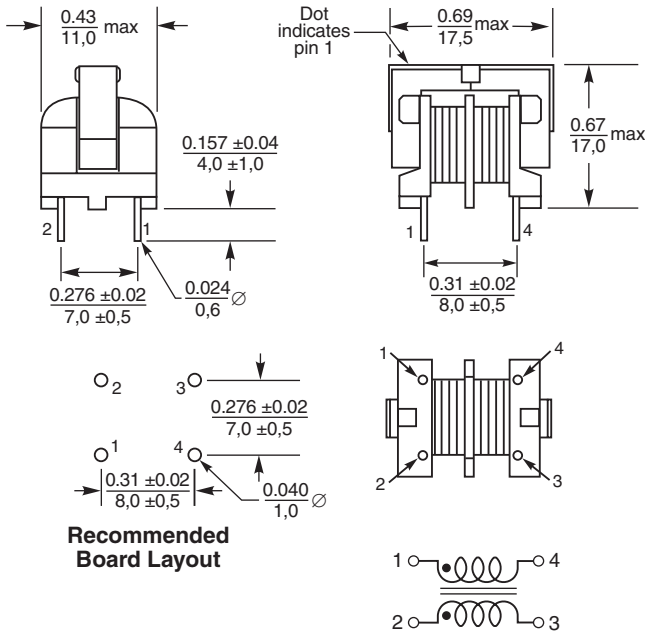

## BU9HS

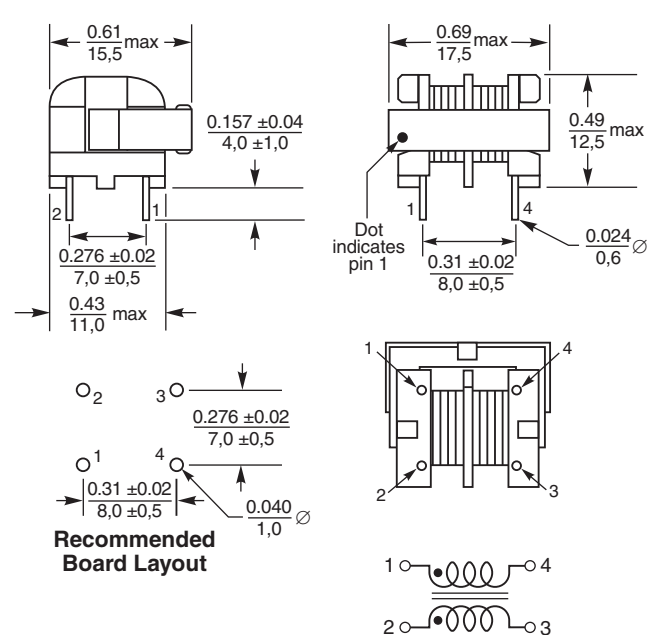



# Common Mode Chokes - BU9, BU9H Series

Part number	Common mode peak impedance (kOhms)	Inductance <sup>1</sup> min (mH)	DCR <sup>2</sup> (Ohms)	Isolation <sup>3</sup> (Vrms)	Current max (A)
BU9-103R25BL	123.5 @ 250 kHz	10.0	3.5	1000	0.25
BU9-2820R5BL	25.12 @ 660 kHz	2.8	1.0	1000	0.50
BU9-1320R7BL	17.33 @ 910 kHz	1.3	0.5	1000	0.70
BU9-6011R0BL	5.43 @ 2100 kHz	0.6	0.2	1000	1.00
BU9-2011R6BL	3.62 @ 4000 kHz	0.2	0.1	1000	1.60
BU9H-103R25BL	148.2 @ 230 kHz	10.0	3.5	1000	0.25
BU9H-2820R5BL	29.76 @ 600 kHz	2.8	1.0	1000	0.50
BU9H-1320R7BL	12.31 @ 980 kHz	1.3	0.5	1000	0.70
BU9H-6011R0BL	5.47 @ 2000 kHz	0.6	0.2	1000	1.00
BU9H-2011R6BL	4.43 @ 2700 kHz	0.2	0.1	1000	1.60

1. Inductance tested at 1 kHz, 1 Vrms, 0 Adc on an Agilent/HP 4284A LCR-meter or equivalent.
2. DCR is per winding
3. Interwinding isolation (hipot) tested for one minute.
4. Electrical specifications at 25°C.

## BU9

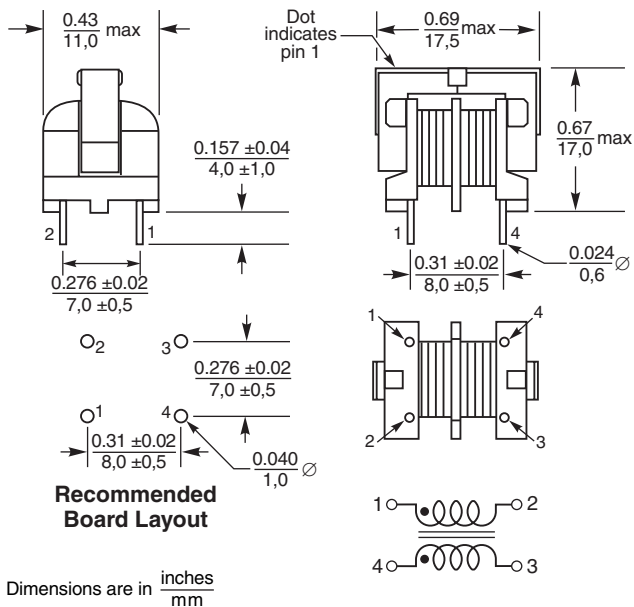

## BU9H

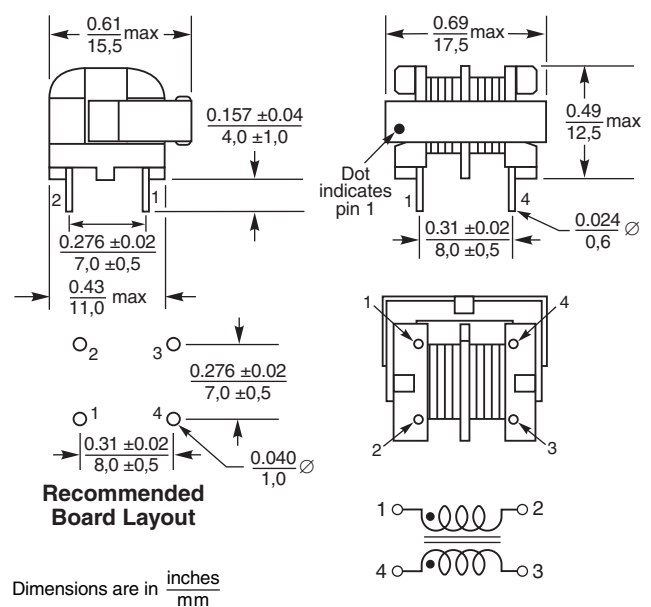



# Common Mode Chokes - BU10 Series

Part number	Common mode peak impedance (kOhms)	Inductance <sup>1</sup> min (mH)	DCR <sup>2</sup> (Ohms)	Isolation <sup>3</sup> (Vrms)	Current max (A)
BU10-1811R2BL	5.27 @ 1200 MHz	0.18	0.20	1000	1.20
BU10-1311R6BL	3.60 @ 1200 MHz	0.13	0.12	1000	1.60
BU10-1012R2BL	1.88 @ 1500 MHz	0.10	0.08	1000	2.20
BU10-6003R0BL	1.15 @ 2100 MHz	0.06	0.04	1000	3.00

1. Inductance tested at 1 kHz, 1 Vrms, 0 Adc on an Agilent/HP 4284A LCR-meter or equivalent.
2. DCR is per winding
3. Interwinding isolation (hipot) tested for one minute.
4. Electrical specifications at 25°C.

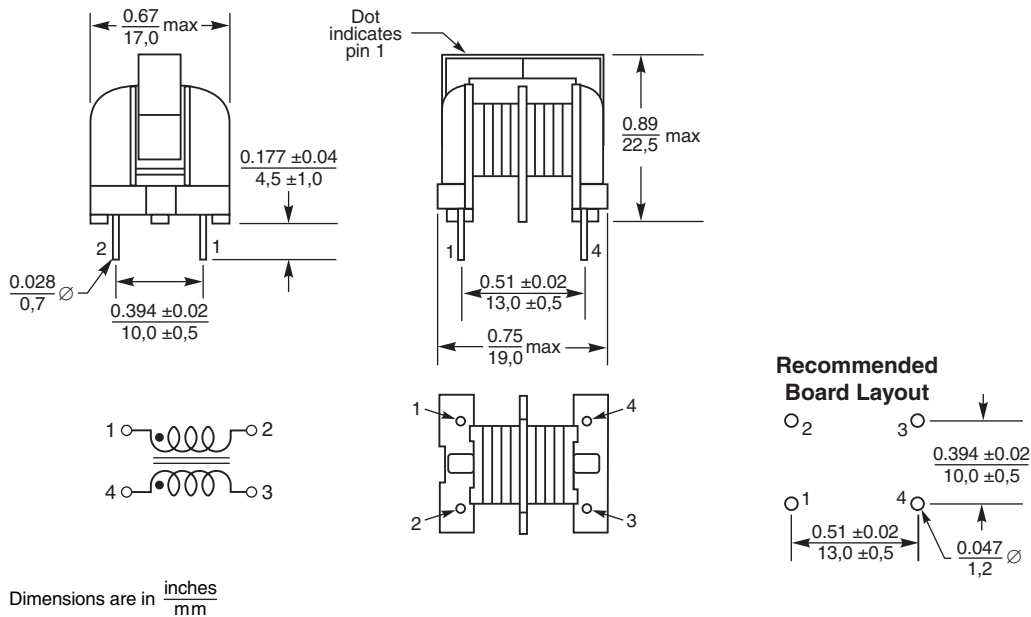



# Common Mode Chokes - BU15 Series

Part number	Common mode peak impedance (kOhms)	Inductance <sup>1</sup> min (mH)	DCR <sup>2</sup> (Ohms)	Isolation <sup>3</sup> (Vrms)	Current max (A)
BU15-4530R4BL	398.7 @ 130 kHz	45.0	3.0	1000	0.40
BU15-1430R7BL	70.58 @ 240 kHz	14.0	1.0	1000	0.70
BU15-7521R0BL	43.05 @ 340 kHz	7.5	0.6	1000	1.00
BU15-4421R3BL	41.14 @ 510 kHz	4.4	0.3	1000	1.30
BU15-2721R6BL	32.22 @ 620 kHz	2.7	0.2	1000	1.60

1. Inductance tested at 1 kHz, 1 Vrms, 0 Adc on an Agilent/HP 4284A LCR-meter or equivalent.
2. DCR is per winding
3. Interwinding isolation (hipot) tested for one minute.
4. Electrical specifications at 25°C.

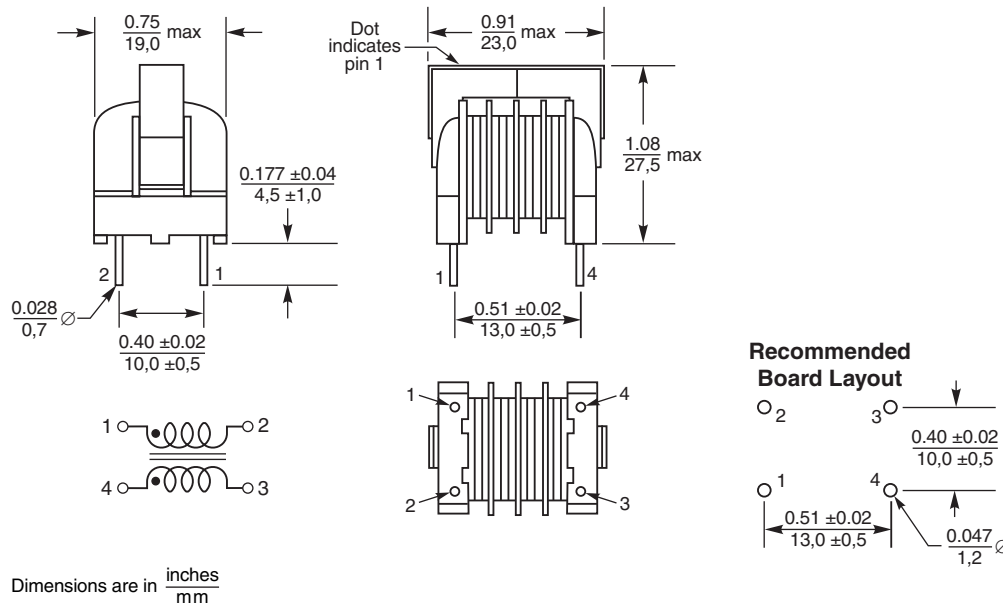



# Common Mode Chokes - BU16 Series

Part number	Common mode peak impedance (kOhms)	Inductance <sup>1</sup> min (mH)	DCR <sup>2</sup> (Ohms)	Isolation <sup>3</sup> (Vrms)	Current max (A)
BU16-4530R5BL	269.6 @ 130 kHz	45.0	2.3	1000	0.50
BU16-2530R7BL	208.3 @ 190 kHz	25.0	1.3	1000	0.70
BU16-1031R0BL	57.14 @ 310 kHz	10.0	0.5	1000	1.00
BU16-4021R5BL	26.26 @ 470 kHz	4.0	0.3	1000	1.50
BU16-2022R0BL	14.47 @ 720 kHz	2.0	0.2	1000	2.00

1. Inductance tested at 1 kHz, 1 Vrms, 0 Adc on an Agilent/HP 4284A LCR-meter or equivalent.
2. DCR is per winding
3. Interwinding isolation (hipot) tested for one minute.
4. Electrical specifications at 25°C.

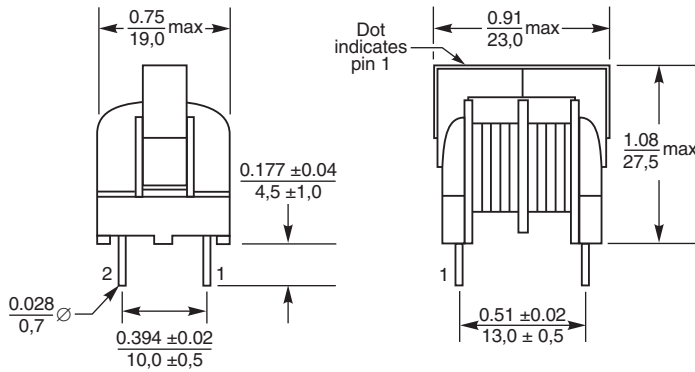

### Recommended Board Layout

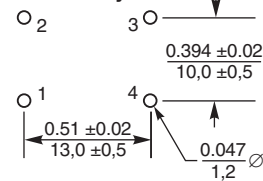

Dimensions are in  $\frac{\text{inches}}{\text{mm}}$



**US** +1-847-639-6400 sales@coilcraft.com  
**UK** +44-1236-730595 sales@coilcraft-europe.com  
**Taiwan** +886-2-2264 3646 sales@coilcraft.com.tw  
**China** +86-21-6218 8074 sales@coilcraft.com.cn  
**Singapore** + 65-6484 8412 sales@coilcraft.com.sg

Document 260-6 Revised 09/12/17

© Coilcraft Inc. 2017  
 This product may not be used in medical or high risk applications without prior Coilcraft approval. Specification subject to change without notice. Please check web site for latest information.