

# Spread Aware™, Ten/Eleven Output Zero Delay Buffer

## Features

- Spread Aware™ designed to work with spread spectrum frequency timing generator (SSFTG) reference signals
- Well suited to both 100- and 133-MHz designs  
Ten (CY2509) or eleven (CY2510) low-voltage complementary metal oxide semiconductor (LVCMOS) / low-voltage transistor-transistor logic (LVTTTL) outputs.
- 50 ps typical peak cycle-to-cycle jitter
- Single output enable pin for CY2510 version, dual pins on CY2509 devices allow shutting down a portion of the outputs
- 3.3 V power supply
- On-chip 25 Ω damping resistors
- Available in 24-pin thin shrunk small outline package (TSSOP) package
- Improved tracking skew, but narrower frequency support limit when compared to W132-09B/10B

## Key Specifications

- Operating voltage: .....3.3 V ± 10%
- Operating range: .....40 MHz < f<sub>OUT</sub> < 140 MHz
- Cycle-to-cycle jitter: .....<100 ps
- Output to output skew: .....<100 ps
- Phase error jitter: .....<100 ps

For a complete list of related documentation, click [here](#).

## Logic Block Diagram

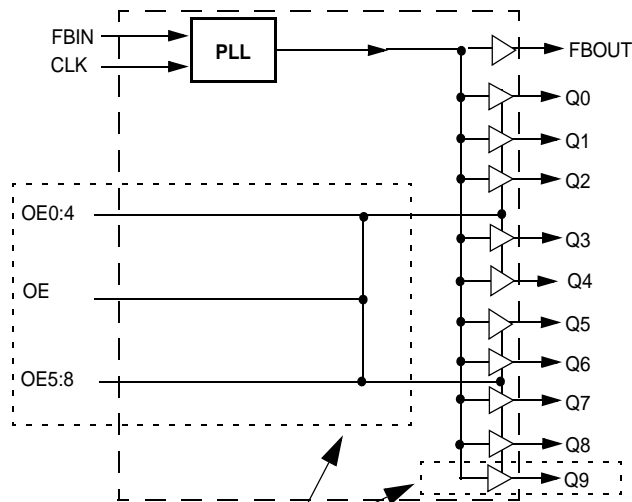

Configuration of these blocks dependent upon specific option being used

## Contents

<b>Pin Configurations</b> .....	<b>3</b>	<b>Package Diagram</b> .....	<b>9</b>
<b>Pin Definitions</b> .....	<b>4</b>	<b>Acronyms</b> .....	<b>10</b>
<b>Functional Overview</b> .....	<b>4</b>	<b>Document Conventions</b> .....	<b>10</b>
Spread Aware™ .....	5	Units of Measure .....	10
How to Implement Zero Delay .....	5	<b>Document History Page</b> .....	<b>11</b>
Inserting Other Devices in Feedback Path .....	5	<b>Sales, Solutions, and Legal Information</b> .....	<b>12</b>
<b>Absolute Maximum Ratings</b> .....	<b>6</b>	Worldwide Sales and Design Support .....	12
<b>DC Electrical Characteristics</b> .....	<b>6</b>	Products .....	12
<b>AC Electrical Characteristics</b> .....	<b>7</b>	PSoC® Solutions .....	12
<b>Ordering Information</b> .....	<b>8</b>	Cypress Developer Community .....	12
Ordering Code Definitions .....	8	Technical Support .....	12

### Pin Configurations

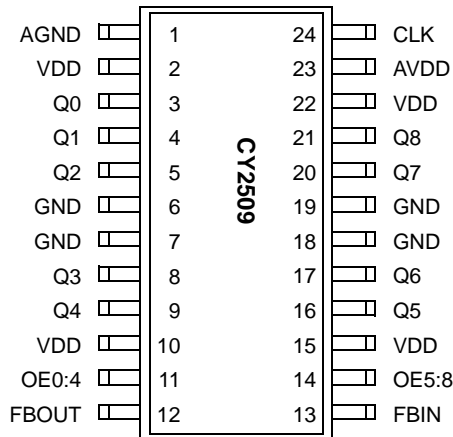
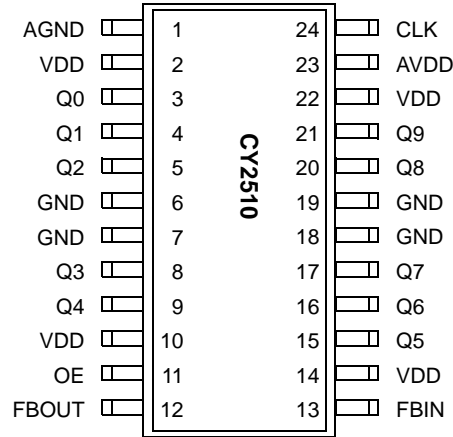

## Pin Definitions

Pin Name	Pin No. (2509)	Pin No. (2510)	Pin Type	Pin Description
CLK	24	24	I	<b>Reference input:</b> Output signals Q0:9 will be synchronized to this signal.
FBIN	13	13	I	<b>Feedback input:</b> This input must be fed by one of the outputs (typically FBOUT) to ensure proper functionality. If the trace between FBIN and FBOUT is equal in length to the traces between the outputs and the signal destinations, then the signals received at the destinations will be synchronized to the CLK signal input.
Q0:8	3, 4, 5, 8, 9, 16, 17, 20, 21	3, 4, 5, 8, 9, 15, 16, 17, 20	O	<b>Integrated series resistor outputs:</b> The frequency and phase of the signals provided by these pins will be equal to the reference signal if properly laid out. Each output has a 25 $\Omega$ series damping resistor integrated.
Q9	n/a	21	O	<b>Integrated series resistor output:</b> The frequency and phase of the signal provided by this pin will be equal to the reference signal if properly laid out. This output has a 25 $\Omega$ series damping resistor integrated.
FBOUT	12	12	O	<b>Feedback output:</b> This output has a 25 $\Omega$ series resistor integrated on chip. Typically it is connected directly to the FBIN input with a trace equal in length to the traces between outputs Q0:9 and the destination points of these output signals.
AVDD	23	23	P	<b>Analog power connection:</b> Connect to 3.3 V. Use ferrite beads to help reduce noise for optimal jitter performance.
AGND	1	1	G	<b>Analog ground connection:</b> Connect to common system ground plane.
VDD	2, 10, 15, 22	2, 10, 14, 22	P	<b>Power connections:</b> Connect to 3.3 V. Use ferrite beads to help reduce noise for optimal jitter performance.
GND	6, 7, 18, 19	6, 7, 18, 19	G	<b>Ground connections:</b> Connect to common system ground plane.
OE	n/a	11	I	<b>Output enable input:</b> Tie to $V_{DD}$ (HIGH, 1) for normal operation. When brought to GND (LOW, 0) all outputs are disabled to a LOW state.
OE0:4	11	n/a	I	<b>Output enable input:</b> Tie to $V_{DD}$ (HIGH, 1) for normal operation. When brought to GND (LOW, 0) outputs Q0:4 are disabled to a LOW state.
OE5:8	14	n/a	I	<b>Output enable input:</b> Tie to $V_{DD}$ (HIGH, 1) for normal operation. When brought to GND (LOW, 0) outputs Q5:8 are disabled to a LOW state.

## Functional Overview

The CY2509/10 is a PLL-based clock driver designed for use in dual inline memory modules. The clock driver has output frequencies of up to 133 MHz and output to output skews of less than 250 ps. The CY2509/10 provides minimum cycle-to-cycle and long-term jitter, which is of significant importance to meet the tight input-to-input skew budget in DIMM applications.

The current generation of 256- and 512-megabyte memory modules needs to support 100-MHz clocking speeds. Especially for cards configured in 16x4 or 8x8 format, the clock signal provided from the motherboard is generally not strong enough to meet all the requirements of the memory and logic on the DIMM.

The CY2509/10 takes in the signal from the motherboard and buffers out clock signals with enough drive to support all the DIMM board clocking needs. The CY2509/10 is also designed to meet the needs of new PC133 SDRAM designs, operating to 133 MHz.

The CY2509/10 was specifically designed to accept SSFTG signals currently being used in motherboard designs to reduce EMI. Zero delay buffers which are not designed to pass this feature through may cause skewing failures.

Output enable pins allow for shutdown of output when they are not being used. This reduces EMI and power consumption.

Figure 1. CY2510 Example Schematic

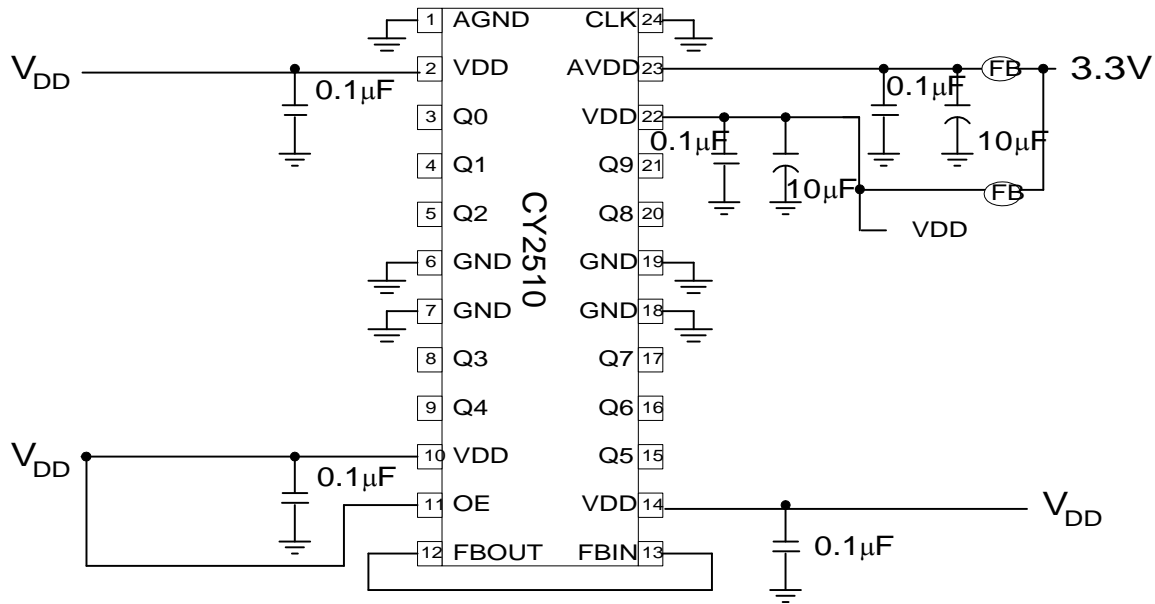

**Spread Aware™**

Many systems being designed now utilize a technology called Spread Spectrum Frequency Timing Generation. Cypress has been one of the pioneers of SSFTG development, and we designed this product so as not to filter off the Spread Spectrum feature of the Reference input, assuming it exists. When a zero delay buffer is not designed to pass the SS feature through, the result is a significant amount of tracking skew which may cause problems in systems requiring synchronization.

For more details on Spread Spectrum timing technology, please see the Cypress application note titled, "EMI Suppression Techniques with SSFTG ICs."

**How to Implement Zero Delay**

Typically, Zero Delay Buffers (ZDBs) are used because a designer wants to provide multiple copies of a clock signal in phase with each other. The whole concept behind ZDBs is that the signals at the destination chips are all going HIGH at the same time as the input to the ZDB. In order to achieve this, layout must compensate for trace length between the ZDB and the target devices. The method of compensation is described below.

External feedback is the trait that allows for this compensation. Since the PLL on the ZDB will cause the feedback signal to be in phase with the reference signal. When laying out the board, match the trace lengths between the output being used for feedback and the FBIN input to the PLL.

If it is desirable to either add a little delay, or slightly precede the input signal, this may also be affected by either making the trace to the FBIN pin a little shorter or a little longer than the traces to the devices being clocked.

**Inserting Other Devices in Feedback Path**

Another nice feature available due to the external feedback is the ability to synchronize signals up to the signal coming from some other device. This implementation can be applied to any device (ASIC, multiple output clock buffer/driver, etc.) which is put into the feedback path.

Referring to Figure 2, if the traces between the ASIC/buffer and the destination of the clock signal(s) (A) are equal in length to the trace between the buffer and the FBIN pin, the signals at the destination(s) device will be driven HIGH at the same time the Reference clock provided to the ZDB goes HIGH. Synchronizing the other outputs of the ZDB to the outputs from the ASIC/Buffer is more complex however, as any propagation delay in the ASIC/Buffer must be accounted for.

Figure 2. Additional Buffering Feedback Path Example Schematic

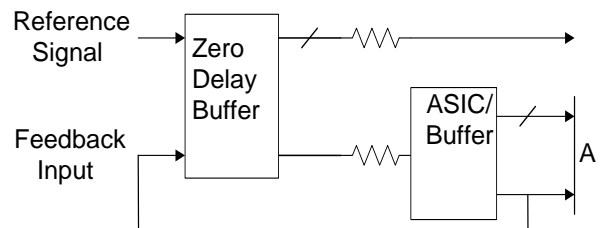

## Absolute Maximum Ratings

Stresses greater than those listed in Absolute Maximum Ratings <sup>[1]</sup> table may cause permanent damage to the device. These represent a stress rating only. Operation of the device at these or any other conditions above those specified in the operating sections of this specification is not implied. Maximum conditions for extended periods may affect reliability.

Parameter	Description	Min	Max	Unit
$V_{DD}, V_{IN}$	Voltage on any pin with respect to GND	-0.5	+7.0	V
$T_{STG}$	Storage temperature	-65	+150	°C
$T_A$	Operating temperature	0	+70	°C
$T_B$	Ambient temperature under bias	-55	+125	°C
$P_D$	Power dissipation	0.5	-	W

## DC Electrical Characteristics

$T_A = 0\text{ °C to }70\text{ °C}$ ,  $V_{DD} = 3.3\text{ V } \pm 10\%$

Parameter	Description	Test Condition	Min	Typ	Max	Unit
$I_{DD}$	Supply current	Unloaded, 100 MHz	-	-	200	mA
$V_{IL}$	Input low voltage		-	-	0.8	V
$V_{IH}$	Input high voltage		2.0	-	$V_{DD} + 0.3$	V
$V_{OL}$	Output low voltage	$I_{OL} = 12\text{ mA}$	-	-	0.8	V
$V_{OH}$	Output high voltage	$I_{OH} = -12\text{ mA}$	2.1	-	-	V
$I_{IL}$	Input low current	$V_{IN} = 0\text{ V}$	-	-	50	μA
$I_{IH}$	Input high current	$V_{IN} = V_{DD}$	-	-	50	μA

### Note

1. **Multiple Supplies:** The voltage on any input or I/O pin cannot exceed the power pin during power-up. Power supply sequencing is NOT required.

## AC Electrical Characteristics

$T_A = 0\text{ }^{\circ}\text{C}$  to  $+70\text{ }^{\circ}\text{C}$ ,  $V_{DD} = 3.3\text{ V} \pm 10\%$

Parameter	Description	Test Condition	Min	Typ	Max	Unit
$f_{OUT}$	Output frequency	30-pF load <sup>[2]</sup>	40	–	140	MHz
$t_R$	Output rise time	0.8 V to 2.0 V, 30-pF load	–	–	2.1	ns
$t_F$	Output fall time	2.0 V to 0.8 V, 30-pF load	–	–	2.5	ns
$t_{iCLKR}$	Input clock rise time <sup>[3]</sup>		–	–	4.5	ns
$t_{iCLKF}$	Input clock fall time <sup>[3]</sup>		–	–	4.5	ns
$t_{PEJ}$	CLK to FBIN Skew Variation <sup>[4, 5]</sup>	Measured at $V_{DD}/2$	–350	0	350	ps
$t_{SK}$	Output to output skew	All outputs loaded equally	–100	0	100	ps
$t_D$	Duty cycle	30-pF load	43	50	58	%
$t_{LOCK}$	PLL lock time	Power supply stable	–	–	1.0	ms
$t_{JC}$	Jitter, Cycle-to-cycle		–	50	100	ps

### Notes

2. Production tests are run at 133 MHz.
3. Longer input rise and fall time will degrade skew and jitter performance.
4. Skew is measured at  $V_{DD}/2$  on rising edges.
5. Duty cycle is measured at  $V_{DD}/2$ .

### Ordering Information

Ordering Code	Package Type	Temperature Range
<b>Pb-free</b>		
CY2510ZXC-1	24-pin TSSOP	Commercial
CY2510ZXC-1T	24-pin TSSOP - Tape and Reel	Commercial

### Ordering Code Definitions

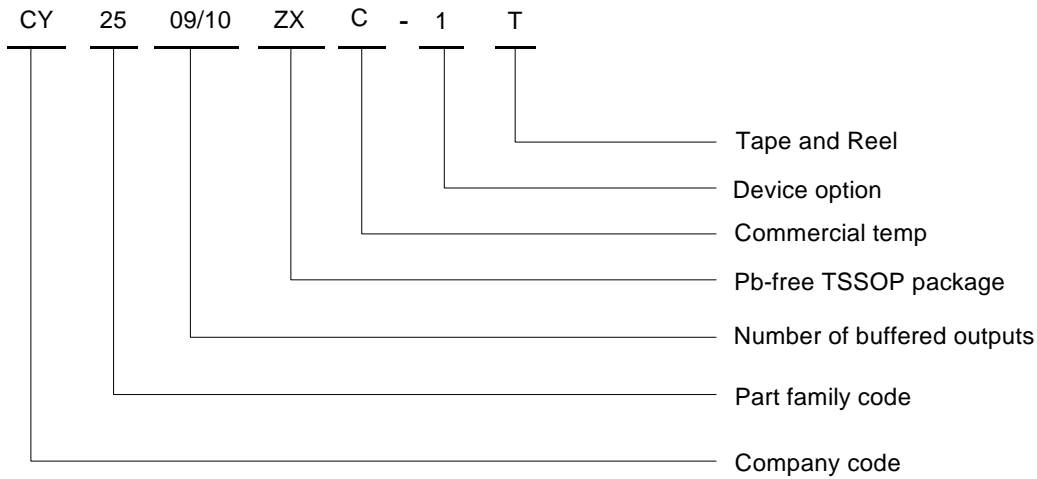



Package Diagram

Figure 3. 24-pin TSSOP (4.40 mm Body) Z24.173/ZZ24.173 Package Outline, 51-85119

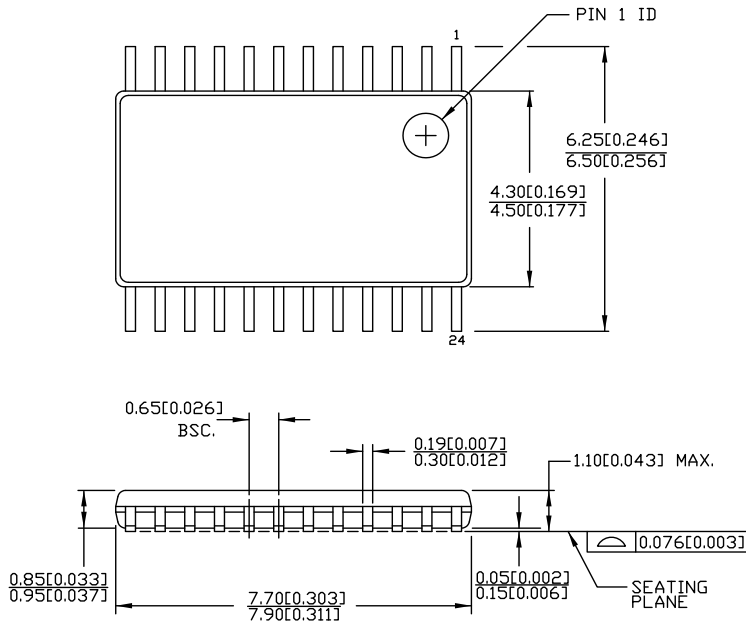

DIMENSIONS IN MM[INCHES] MIN. MAX.

REFERENCE JEDEC MO-153

PART #	
Z24.173	STANDARD PKG.
ZZ24.173	LEAD FREE PKG.

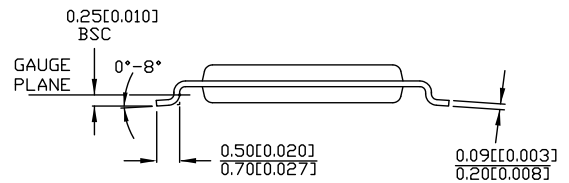

51-85119 \*E

**Acronyms**

Acronym	Description
EMI	Electromagnetic Interference
LVC MOS	Low-Voltage Complementary Metal Oxide Semiconductor
LV TTL	Low-Voltage Transistor-Transistor Logic
PLL	Phase-Locked Loop
SSFTG	Spread Spectrum Frequency Timing Generator
TSSOP	Thin Shrunk Small Outline Package
ZDB	Zero Delay Buffer

**Document Conventions**

**Units of Measure**

Symbol	Unit of Measure
°C	degree Celsius
Hz	hertz
kHz	kilohertz
MHz	megahertz
µA	microampere
mA	milliampere
ms	millisecond
mV	millivolt
ns	nanosecond
Ω	ohm
ppm	parts per million
%	percent
V	volt

**Document History Page**

Document Title: CY2509/10, Spread Aware™, Ten/Eleven Output Zero Delay Buffer Document Number: 38-07230				
Rev.	ECN No.	Issue Date	Orig. of Change	Description of Change
**	110495	01/07/02	SZV	Change from Spec number: 38-00914 to 38-07230
*A	122844	12/14/02	RBI	Power up requirements added to Operating Conditions Information
*B	352015	See ECN	RGL	Added typical jitter and max. V <sub>IH</sub> numbers Added Lead-free devices
*C	385383	See ECN	RGL	Minor Change: Replaced the wrong package drawing
*D	2897373	03/22/10	CXQ	Updated ordering information table. Removed part numbers CY2509ZC-1, CY2510ZC-1, CY2509ZC-1T, CY2510ZC-1T Updated package diagram Updated copyright section
*E	3302008	07/05/11	CXQ	Updated <a href="#">Functional Overview</a> : Updated <a href="#">Figure 1</a> caption. Updated <a href="#">Figure 2</a> caption. Added <a href="#">Ordering Code Definitions</a> . Updated <a href="#">Package Diagram</a> . Added <a href="#">Acronyms and Units of Measure</a> . Updated to latest template
*F	4399665	06/05/2014	AJU	Updated <a href="#">Package Diagram</a> : spec 51-85119 – Changed revision from *C to *D. Updated in new template. Completing Sunset Review.
*G	4581659	11/28/2014	TAVA	Added related documentation hyperlink in page 1. Updated package diagram.

## Sales, Solutions, and Legal Information

### Worldwide Sales and Design Support

Cypress maintains a worldwide network of offices, solution centers, manufacturer's representatives, and distributors. To find the office closest to you, visit us at [Cypress Locations](#).

#### Products

<a href="#">Automotive</a>	<a href="#">cypress.com/go/automotive</a>
<a href="#">Clocks &amp; Buffers</a>	<a href="#">cypress.com/go/clocks</a>
<a href="#">Interface</a>	<a href="#">cypress.com/go/interface</a>
<a href="#">Lighting &amp; Power Control</a>	<a href="#">cypress.com/go/powerpsoc</a> <a href="#">cypress.com/go/plc</a>
<a href="#">Memory</a>	<a href="#">cypress.com/go/memory</a>
<a href="#">PSoC</a>	<a href="#">cypress.com/go/psoc</a>
<a href="#">Touch Sensing</a>	<a href="#">cypress.com/go/touch</a>
<a href="#">USB Controllers</a>	<a href="#">cypress.com/go/USB</a>
<a href="#">Wireless/RF</a>	<a href="#">cypress.com/go/wireless</a>

#### PSoC<sup>®</sup> Solutions

[psoc.cypress.com/solutions](#)  
[PSoC 1](#) | [PSoC 3](#) | [PSoC 4](#) | [PSoC 5LP](#)

#### Cypress Developer Community

[Community](#) | [Forums](#) | [Blogs](#) | [Video](#) | [Training](#)

#### Technical Support

[cypress.com/go/support](#)

---

© Cypress Semiconductor Corporation, 2010-2014. The information contained herein is subject to change without notice. Cypress Semiconductor Corporation assumes no responsibility for the use of any circuitry other than circuitry embodied in a Cypress product. Nor does it convey or imply any license under patent or other rights. Cypress products are not warranted nor intended to be used for medical, life support, life saving, critical control or safety applications, unless pursuant to an express written agreement with Cypress. Furthermore, Cypress does not authorize its products for use as critical components in life-support systems where a malfunction or failure may reasonably be expected to result in significant injury to the user. The inclusion of Cypress products in life-support systems application implies that the manufacturer assumes all risk of such use and in doing so indemnifies Cypress against all charges.

Any Source Code (software and/or firmware) is owned by Cypress Semiconductor Corporation (Cypress) and is protected by and subject to worldwide patent protection (United States and foreign), United States copyright laws and international treaty provisions. Cypress hereby grants to licensee a personal, non-exclusive, non-transferable license to copy, use, modify, create derivative works of, and compile the Cypress Source Code and derivative works for the sole purpose of creating custom software and or firmware in support of licensee product to be used only in conjunction with a Cypress integrated circuit as specified in the applicable agreement. Any reproduction, modification, translation, compilation, or representation of this Source Code except as specified above is prohibited without the express written permission of Cypress.

Disclaimer: CYPRESS MAKES NO WARRANTY OF ANY KIND, EXPRESS OR IMPLIED, WITH REGARD TO THIS MATERIAL, INCLUDING, BUT NOT LIMITED TO, THE IMPLIED WARRANTIES OF MERCHANTABILITY AND FITNESS FOR A PARTICULAR PURPOSE. Cypress reserves the right to make changes without further notice to the materials described herein. Cypress does not assume any liability arising out of the application or use of any product or circuit described herein. Cypress does not authorize its products for use as critical components in life-support systems where a malfunction or failure may reasonably be expected to result in significant injury to the user. The inclusion of Cypress' product in a life-support systems application implies that the manufacturer assumes all risk of such use and in doing so indemnifies Cypress against all charges.

Use may be limited by and subject to the applicable Cypress software license agreement.