

# Automotive PSoC<sup>®</sup> Programmable System-on-Chip<sup>™</sup>

## Features

- Automotive Electronics Council (AEC) qualified
- Powerful Harvard-architecture processor
  - M8C processor speeds up to 24 MHz
  - Two 8 × 8 multiply, 32-bit accumulate
  - Low power at high speed
  - Operating voltage: 3.0 V to 5.25 V
  - Automotive temperature range: -40 °C to +85 °C
- Advanced peripherals (PSoC<sup>®</sup> blocks)
  - Six rail-to-rail analog PSoC blocks provide:
    - Up to 14-bit analog-to-digital converters (ADCs)
    - Up to 9-bit digital-to-analog converters (DACs)
    - Programmable gain amplifiers (PGAs)
    - Programmable filters and comparators
  - Four digital PSoC blocks provide:
    - 8- to 32-bit timers, counters, and pulse-width modulators (PWMs)
    - Cyclic redundancy check (CRC) and pseudo-random sequence (PRS) modules
    - Full- or half-duplex UART
    - SPI master or slave
    - Connectable to all general purpose I/O (GPIO) pins
  - Complex peripherals by combining blocks
    - Capacitive sensing application capability
- Flexible on-chip memory
  - 16-KB flash program storage, 1000 erase/write cycles
  - 1-KB SRAM data storage
  - In-system serial programming (ISSP)
  - Partial flash updates
  - Flexible protection modes
  - EEPROM emulation in flash
- Programmable pin configurations
  - 25-mA sink, 10-mA drive on all GPIOs
  - Pull-up, pull-down, high Z, strong, or open-drain drive modes on all GPIOs
  - Up to 47 analog inputs on GPIOs
  - Two 30-mA analog outputs on GPIOs
  - Configurable interrupt on all GPIOs
- Precision, programmable clocking
  - Internal ±4% 24/48 MHz oscillator
  - Internal low-speed, low-power oscillator for watchdog and sleep functionality
  - Optional external oscillator, up to 24 MHz
- Additional system resources
  - I<sup>2</sup>C<sup>™</sup> slave, master, or multimaster operation up to 400 kHz
  - Watchdog and sleep timers
  - User-configurable LVD
  - Integrated supervisory circuit
  - On-chip precision voltage reference
- Complete development tools
  - Free development software (PSoC Designer<sup>™</sup>)
  - Full-featured in-circuit emulator (ICE) and programmer
  - Full-speed emulation
  - Complex breakpoint structure
  - 128-KB trace memory

## Logic Block Diagram

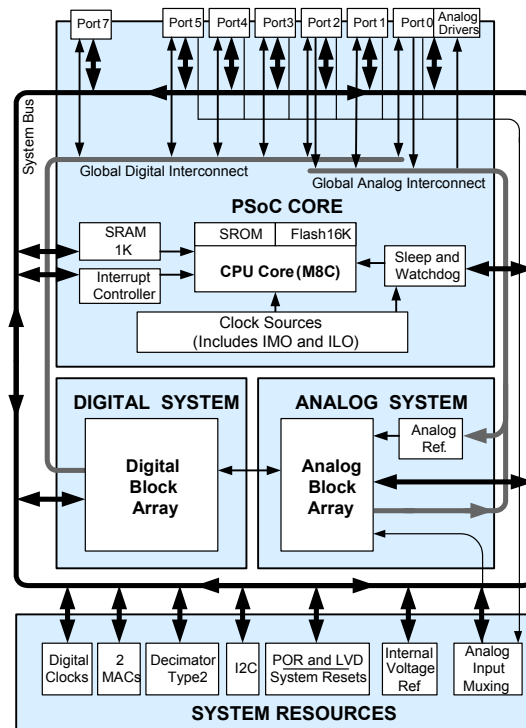

**Errata:** For information on silicon errata, see "Errata" on page 46. Details include trigger conditions, devices affected, and proposed workaround.

## Contents

<b>PSoC Functional Overview</b> .....	<b>3</b>	DC Electrical Characteristics .....	14
The PSoC Core .....	3	AC Electrical Characteristics .....	27
The Digital System .....	3	<b>Packaging Information</b> .....	<b>35</b>
The Analog System .....	4	Thermal Impedances .....	35
Additional System Resources .....	5	Solder Reflow Specifications .....	35
PSoC Device Characteristics .....	5	Tape and Reel Information .....	36
<b>Getting Started</b> .....	<b>6</b>	<b>Development Tool Selection</b> .....	<b>37</b>
Application Notes .....	6	Software .....	37
Development Kits .....	6	Development Kits .....	37
Training .....	6	Evaluation Tools .....	37
CYPros Consultants .....	6	Device Programmers .....	38
Solutions Library .....	6	Accessories (Emulation and Programming) .....	38
Technical Support .....	6	<b>Ordering Information</b> .....	<b>39</b>
<b>Development Tools</b> .....	<b>6</b>	Ordering Code Definitions .....	39
PSoC Designer Software Subsystems .....	6	<b>Acronyms</b> .....	<b>40</b>
<b>Designing with PSoC Designer</b> .....	<b>7</b>	<b>Reference Documents</b> .....	<b>40</b>
Select User Modules .....	7	<b>Document Conventions</b> .....	<b>41</b>
Configure User Modules .....	7	Units of Measure .....	41
Organize and Connect .....	7	Numeric Conventions .....	41
Generate, Verify, and Debug .....	7	<b>Glossary</b> .....	<b>41</b>
<b>Pinouts</b> .....	<b>8</b>	<b>Errata</b> .....	<b>46</b>
56-Pin Part Pinout (with XRES pin) .....	8	Part Numbers Affected .....	46
<b>Registers</b> .....	<b>9</b>	CY8C24x94 Errata Summary .....	46
Register Conventions .....	9	<b>Document History Page</b> .....	<b>50</b>
Register Mapping Tables .....	9	<b>Sales, Solutions, and Legal Information</b> .....	<b>52</b>
Register Map Bank 0 Table: User Space .....	10	Worldwide Sales and Design Support .....	52
Register Map Bank 1 Table: Configuration Space .....	11	Products .....	52
<b>Electrical Specifications</b> .....	<b>12</b>	PSoC® Solutions .....	52
Absolute Maximum Ratings .....	13	Cypress Developer Community .....	52
Operating Temperature .....	13	Technical Support .....	52

## PSoC Functional Overview

The PSoC family consists of many programmable system-on-chips with on-chip controller devices. All PSoC family devices are designed to replace traditional microcontroller units (MCUs), system ICs, and the numerous discrete components that surround them. Configurable analog, digital, and interconnect circuitry enable a high level of integration in a host of industrial, consumer, and communication applications.

This architecture allows the user to create customized peripheral configurations that match the requirements of each individual application. Additionally, a fast CPU, Flash program memory, SRAM data memory, and configurable I/O are included in a range of convenient pinouts and packages.

The PSoC architecture, as illustrated in the [Logic Block Diagram on page 1](#), is comprised of four main areas: PSoc Core, digital system, analog system, and system resources. Configurable global busing allows all the device resources to be combined into a complete custom system. The PSoC CY8C24x94 devices can have up to seven I/O ports that connect to the global digital and analog interconnects, providing access to four digital blocks and six analog blocks.

### The PSoC Core

The PSoC Core is a powerful engine that supports a rich feature set. The core includes a CPU, memory, clocks, and configurable GPIOs.

The M8C CPU core is a powerful processor with speeds up to 24 MHz, providing a four-MIPS 8-bit Harvard architecture micro-processor. The CPU uses an interrupt controller with up to 20 vectors, to simplify programming of real-time embedded events. Program execution is timed and protected using the included sleep timer and watchdog timer (WDT).

Memory encompasses 16 KB of flash for program storage, 1 KB of SRAM for data storage, and up to 2 KB of emulated EEPROM using the flash. Program flash has four protection levels on blocks of 64 bytes, allowing customized software IP protection.

The PSoC device incorporates flexible internal clock generators, including a 24-MHz internal main oscillator (IMO) accurate to  $\pm 4\%$  over temperature and voltage. The 24-MHz IMO can also be doubled to 48 MHz for use by the digital system. A low power 32-kHz internal low-speed oscillator (ILO) is provided for the sleep timer and WDT. The clocks, together with programmable clock dividers (as system resources), provide the flexibility to integrate almost any timing requirement into the PSoC device.

PSoc GPIOs provide connection to the CPU, digital resources, and analog resources of the device. Each pin's drive mode may be selected from eight options, allowing great flexibility in external interfacing. Every pin is also capable of generating a system interrupt.

## The Digital System

The digital system is composed of four digital PSoC blocks. Each block is an 8-bit resource used alone or combined with other blocks to form 8-, 16-, 24-, and 32-bit peripherals, which are called user modules.

**Figure 1. Digital System Block Diagram**

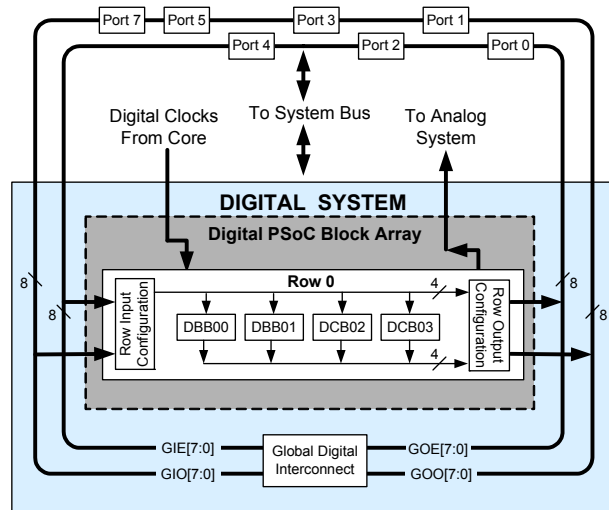

Digital peripheral configurations include those listed below.

- PWMs (8- to 32-bit)
- PWMs with Dead band (8- to 24-bit)
- Counters (8- to 32-bit)
- Timers (8- to 32-bit)
- Full- or half-duplex 8-bit UART with selectable parity
- SPI master and slave
- I<sup>2</sup>C master, slave, or multimaster (implemented in a dedicated I<sup>2</sup>C block)
- Cyclic redundancy checker/generator (16-bit)
- Infrared Data Association (IrDA)
- PRS generators (8- to 32-bit)

The digital blocks can be connected to any GPIO through a series of global buses that can route any signal to any pin. The buses also allow signal multiplexing and performing logic operations. This configurability frees your designs from the constraints of a fixed peripheral controller.

Digital blocks are provided in rows of four, where the number of blocks varies by PSoC device family. This allows you the optimum choice of system resources for your application. Family resources are shown in [Table 1 on page 5](#).

### The Analog System

The analog system is composed of six configurable blocks, each comprised of an opamp circuit allowing the creation of complex analog signal flows. Analog peripherals are very flexible and can be customized to support specific application requirements. Some of the more common PSoC analog functions (most available as user modules) are listed below.

- ADCs (up to two, with 6- to 14-bit resolution, selectable as incremental, delta-sigma, or successive approximation register (SAR))
- Filters (Two- and Four-pole band pass, low pass, and notch)
- Amplifiers (up to two, with selectable gain to 48x)
- Instrumentation amplifiers (one with selectable gain to 93x)
- Comparators (up to two, with 16 selectable thresholds)
- DACs (up to two, with 6- to 9-bit resolution)
- Multiplying DACs (up to two, with 6- to 9-bit resolution)
- High current output drivers (two with 30 mA drive)
- 1.3-V reference (as a system resource)
- DTMF Dialer
- Modulators
- Correlators
- Peak Detectors
- Many other topologies possible

Analog blocks are arranged in a column of three, which includes one continuous time (CT) and two switched capacitor (SC) blocks, as shown in Figure 2.

Figure 2. Analog System Block Diagram

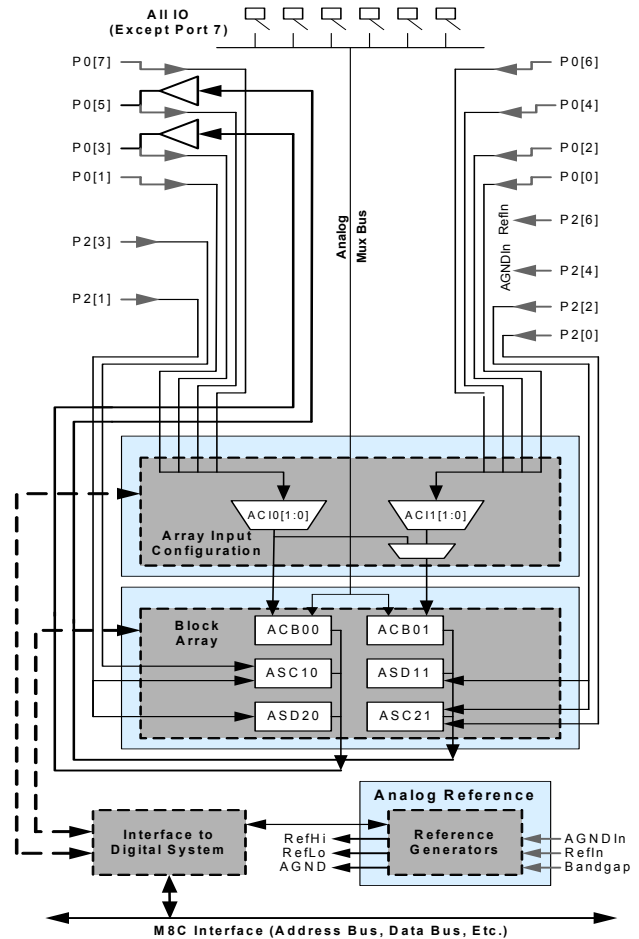

### The Analog Multiplexer System

The analog mux bus can connect to every GPIO pin in ports 0-5. Pins are connected to the bus individually or in any combination. The bus also connects to the analog system for analysis with comparators and ADCs. It can be split into two sections for simultaneous dual-channel processing. An additional 8:1 analog input multiplexer provides a second path to bring Port 0 pins to the analog array.

Switch control logic enables selected pins to precharge continuously under hardware control. This enables capacitive measurement for applications such as touch sensing. Other multiplexer applications include:

- Track pad, finger sensing.
- Chip-wide mux that allows analog input from up to 47 I/O pins.
- Crosspoint connection between any I/O pin combination.

## Additional System Resources

System resources provide additional capability useful for complete systems. Additional resources include a multiplier, decimator, LVD, and power-on reset (POR). Brief statements describing the merits of each resource follow.

- Digital clock dividers provide three customizable clock frequencies for use in applications. The clocks can be routed to both the digital and analog systems. Additional clocks are generated using digital PSoC blocks as clock dividers.
- Two multiply accumulates (MACs) provide fast 8-bit multipliers with 32-bit accumulate, to assist in both general math and digital filters.
- The decimator provides a custom hardware filter for digital signal processing applications including creation of Delta-Sigma ADCs.
- The I<sup>2</sup>C module provides 0 to 400 kHz communication over two wires. Slave, master, and multi-master modes are all supported.
- LVD interrupts can signal the application of falling voltage levels, while the advanced POR circuit eliminates the need for a system supervisor.
- An internal 1.3-V voltage reference provides an absolute reference for the analog system, including ADCs and DACs.
- Versatile analog multiplexer system.

## PSoC Device Characteristics

Depending on your PSoC device characteristics, the digital and analog systems can have varying numbers of digital and analog blocks. The following table lists the resources available for specific PSoC device groups. The device covered by this datasheet is shown in the highlighted row of the table.

**Table 1. PSoC Device Characteristics**

PSoC Part Number	Digital I/O	Digital Rows	Digital Blocks	Analog Inputs	Analog Outputs	Analog Columns	Analog Blocks	SRAM Size	Flash Size
CY8C29x66 <sup>[1]</sup>	up to 64	4	16	up to 12	4	4	12	2 K	32 K
CY8C28xxx	up to 44	up to 3	up to 12	up to 44	up to 4	up to 6	up to 12 + 4 <sup>[2]</sup>	1 K	16 K
CY8C27x43	up to 44	2	8	up to 12	4	4	12	256	16 K
CY8C24x94 <sup>[1]</sup>	up to 56	1	4	up to 48	2	2	6	1 K	16 K
CY8C24x23A <sup>[1]</sup>	up to 24	1	4	up to 12	2	2	6	256	4 K
CY8C23x33	up to 26	1	4	up to 12	2	2	4	256	8 K
CY8C22x45 <sup>[1]</sup>	up to 38	2	8	up to 38	0	4	6 <sup>[2]</sup>	1 K	16 K
CY8C21x45 <sup>[1]</sup>	up to 24	1	4	up to 24	0	4	6 <sup>[2]</sup>	512	8 K
CY8C21x34 <sup>[1]</sup>	up to 28	1	4	up to 28	0	2	4 <sup>[2]</sup>	512	8 K
CY8C21x23	up to 16	1	4	up to 8	0	2	4 <sup>[2]</sup>	256	4 K
CY8C20x34 <sup>[1]</sup>	up to 28	0	0	up to 28	0	0	3 <sup>[2,3]</sup>	512	8 K
CY8C20xx6	up to 36	0	0	up to 36	0	0	3 <sup>[2,3]</sup>	up to 2 K	up to 32 K

### Notes

1. Automotive qualified devices available in this group.
2. Limited analog functionality.
3. Two analog blocks and one CapSense<sup>®</sup> block.

## Getting Started

For in depth information, along with detailed programming details, see the *PSoC<sup>®</sup> Technical Reference Manual*.

For up-to-date ordering, packaging, and electrical specification information, see the latest *PSoC device datasheets* on the web.

## Application Notes

[Cypress application notes](#) are an excellent introduction to the wide variety of possible PSoC designs.

## Development Kits

[PSoC Development Kits](#) are available online from and through a growing number of regional and global distributors, which include Arrow, Avnet, Digi-Key, Farnell, Future Electronics, and Newark.

## Training

[Free PSoC technical training](#) (on demand, webinars, and workshops), which is available online via [www.cypress.com](http://www.cypress.com), covers a wide variety of topics and skill levels to assist you in your designs.

## CYPros Consultants

Certified PSoC consultants offer everything from technical assistance to completed PSoC designs. To contact or become a PSoC consultant go to the [CYPros Consultants](#) web site.

## Solutions Library

Visit our growing [library of solution focused designs](#). Here you can find various application designs that include firmware and hardware design files that enable you to complete your designs quickly.

## Technical Support

[Technical support](#) – including a searchable Knowledge Base articles and technical forums – is also available online. If you cannot find an answer to your question, call our Technical Support hotline at 1-800-541-4736.

## Development Tools

PSoC Designer™ is the revolutionary Integrated Design Environment (IDE) that you can use to customize PSoC to meet your specific application requirements. PSoC Designer software accelerates system design and time to market. Develop your applications using a library of precharacterized analog and digital peripherals (called user modules) in a drag-and-drop design environment. Then, customize your design by leveraging the dynamically generated application programming interface (API) libraries of code. Finally, debug and test your designs with the integrated debug environment, including in-circuit emulation and standard software debug features. PSoC Designer includes:

- Application editor graphical user interface (GUI) for device and user module configuration and dynamic reconfiguration
- Extensive user module catalog
- Integrated source-code editor (C and assembly)

- Free C compiler with no size restrictions or time limits
- Built-in debugger
- In-circuit emulation
- Built-in support for communication interfaces:
  - Hardware and software I<sup>2</sup>C slaves and masters
  - Full-speed USB 2.0
  - Up to four full-duplex universal asynchronous receiver/transmitters (UARTs), SPI master and slave, and wireless

PSoC Designer supports the entire library of PSoC 1 devices and runs on Windows XP, Windows Vista, and Windows 7.

## PSoC Designer Software Subsystems

### Design Entry

In the chip-level view, choose a base device to work with. Then select different onboard analog and digital components that use the PSoC blocks, which are called user modules. Examples of user modules are analog-to-digital converters (ADCs), digital-to-analog converters (DACs), amplifiers, and filters. Configure the user modules for your chosen application and connect them to each other and to the proper pins. Then generate your project. This prepopulates your project with APIs and libraries that you can use to program your application.

The tool also supports easy development of multiple configurations and dynamic reconfiguration. Dynamic reconfiguration makes it possible to change configurations at run time. In essence, this allows you to use more than 100 percent of PSoC's resources for a given application.

### Code Generation Tools

The code generation tools work seamlessly within the PSoC Designer interface and have been tested with a full range of debugging tools. You can develop your design in C, assembly, or a combination of the two.

**Assemblers.** The assemblers allow you to merge assembly code seamlessly with C code. Link libraries automatically use absolute addressing or are compiled in relative mode, and linked with other software modules to get absolute addressing.

**C Language Compilers.** C language compilers are available that support the PSoC family of devices. The products allow you to create complete C programs for the PSoC family devices. The optimizing C compilers provide all of the features of C, tailored to the PSoC architecture. They come complete with embedded libraries providing port and bus operations, standard keypad and display support, and extended math functionality.

### Debugger

PSoC Designer has a debug environment that provides hardware in-circuit emulation, allowing you to test the program in a physical system while providing an internal view of the PSoC device. Debugger commands allow you to read and program and read and write data memory, and read and write I/O registers. You can read and write CPU registers, set and clear breakpoints, and provide program run, halt, and step control. The debugger also allows you to create a trace buffer of registers and memory locations of interest.

### Online Help System

The online help system displays online, context-sensitive help. Designed for procedural and quick reference, each functional subsystem has its own context-sensitive help. This system also provides tutorials and links to FAQs and an Online Support Forum to aid the designer.

### In-Circuit Emulator

A low-cost, high-functionality In-Circuit Emulator (ICE) is available for development support. This hardware can program single devices.

The emulator consists of a base unit that connects to the PC using a USB port. The base unit is universal and operates with all PSoC devices. Emulation pods for each device family are available separately. The emulation pod takes the place of the PSoC device in the target board and performs full-speed (24-MHz) operation.

## Designing with PSoC Designer

The development process for the PSoC<sup>®</sup> device differs from that of a traditional fixed function microprocessor. The configurable analog and digital hardware blocks give the PSoC architecture a unique flexibility that pays dividends in managing specification change during development and by lowering inventory costs. These configurable resources, called PSoC Blocks, have the ability to implement a wide variety of user-selectable functions. The PSoC development process is summarized in four steps:

1. Select [User Modules](#).
2. Configure user modules.
3. Organize and connect.
4. Generate, verify, and debug.

### Select User Modules

PSoC Designer provides a library of prebuilt, pretested hardware peripheral components called “user modules.” User modules make selecting and implementing peripheral devices, both analog and digital, simple.

### Configure User Modules

Each user module that you select establishes the basic register settings that implement the selected function. They also provide parameters and properties that allow you to tailor their precise

configuration to your particular application. For example, a pulse width modulator (PWM) User Module configures one or more digital PSoC blocks, one for each 8 bits of resolution. The user module parameters permit you to establish the pulse width and duty cycle. Configure the parameters and properties to correspond to your chosen application. Enter values directly or by selecting values from drop-down menus. All the user modules are documented in datasheets that may be viewed directly in PSoC Designer or on the Cypress website. These [user module datasheets](#) explain the internal operation of the user module and provide performance specifications. Each datasheet describes the use of each user module parameter, and other information you may need to successfully implement your design.

### Organize and Connect

You build signal chains at the chip level by interconnecting user modules to each other and the I/O pins. You perform the selection, configuration, and routing so that you have complete control over all on-chip resources.

### Generate, Verify, and Debug

When you are ready to test the hardware configuration or move on to developing code for the project, you perform the “Generate Configuration Files” step. This causes PSoC Designer to generate source code that automatically configures the device to your specification and provides the software for the system. The generated code provides application programming interfaces (APIs) with high-level functions to control and respond to hardware events at run time and interrupt service routines that you can adapt as needed.

A complete code development environment allows you to develop and customize your applications in either C, assembly language, or both.

The last step in the development process takes place inside PSoC Designer’s debugger (access by clicking the Connect icon). PSoC Designer downloads the HEX image to the ICE where it runs at full speed. PSoC Designer debugging capabilities rival those of systems costing many times more. In addition to traditional single-step, run-to-breakpoint and watch-variable features, the debug interface provides a large trace buffer and allows you to define complex breakpoint events that include monitoring address and data bus values, memory locations and external signals.

## Pinouts

The automotive CY8C24x94 PSoC device is available in a variety of packages which are listed and illustrated in the following tables. Every port pin (labeled with a “P”) is capable of digital I/O. However, V<sub>SS</sub>, V<sub>DD</sub>, and XRES are not capable of digital I/O.

### 56-Pin Part Pinout (with XRES pin)

Table 2. 56-Pin Part Pinout (QFN)

Pin No.	Type		Name	Description
	Digital	Analog		
1	I/O	I, M	P2[3]	Direct switched capacitor block input
2	I/O	I, M	P2[1]	Direct switched capacitor block input
3	I/O	M	P4[7]	
4	I/O	M	P4[5]	
5	I/O	M	P4[3]	
6	I/O	M	P4[1]	
7	I/O	M	P3[7]	
8	I/O	M	P3[5]	
9	I/O	M	P3[3]	
10	I/O	M	P3[1]	
11	I/O	M	P5[7]	
12	I/O	M	P5[5]	
13	I/O	M	P5[3]	
14	I/O	M	P5[1]	
15	I/O	M	P1[7]	I <sup>2</sup> C serial clock (SCL)
16	I/O	M	P1[5]	I <sup>2</sup> C serial data (SDA)
17	I/O	M	P1[3]	
18	I/O	M	P1[1]	I <sup>2</sup> C SCL, ISSP SCLK <sup>[4]</sup>
19	Power		V <sub>SS</sub>	Ground connection
20	DNC			Do not connect anything to this pin
21	DNC			Do not connect anything to this pin
22	Power		V <sub>DD</sub>	Supply voltage
23	I/O		P7[7]	
24	I/O		P7[0]	
25	I/O	M	P1[0]	I <sup>2</sup> C SDA, ISSP SDATA <sup>[4]</sup>
26	I/O	M	P1[2]	
27	I/O	M	P1[4]	Optional external clock (EXTCLK) input
28	I/O	M	P1[6]	
29	I/O	M	P5[0]	
30	I/O	M	P5[2]	
31	I/O	M	P5[4]	
32	I/O	M	P5[6]	
33	I/O	M	P3[0]	
34	I/O	M	P3[2]	
35	I/O	M	P3[4]	
36	Input		XRES	Active high external reset with internal pull-down
37	I/O	M	P4[0]	
38	I/O	M	P4[2]	
39	I/O	M	P4[4]	
40	I/O	M	P4[6]	
41	I/O	I, M	P2[0]	Direct switched capacitor block input
42	I/O	I, M	P2[2]	Direct switched capacitor block input
43	I/O	M	P2[4]	External analog ground (AGND) input
44	I/O	M	P2[6]	External voltage reference (VREF) input
45	I/O	I, M	P0[0]	Analog column mux input
46	I/O	I, M	P0[2]	Analog column mux input
47	I/O	I, M	P0[4]	Analog column mux input
48	I/O	I, M	P0[6]	Analog column mux input
49	Power		V <sub>DD</sub>	Supply voltage
50	Power		V <sub>SS</sub>	Ground connection
51	I/O	I, M	P0[7]	Analog column mux input
52	I/O	I/O, M	P0[5]	Analog column mux input and column output
53	I/O	I/O, M	P0[3]	Analog column mux input and column output
54	I/O	I, M	P0[1]	Analog column mux input
55	I/O	M	P2[7]	
56	I/O	M	P2[5]	
EP	Power		V <sub>SS</sub>	Exposed pad is not connected internally. Connect to circuit ground for best performance

Figure 3. CY8C24894 56-Pin PSoC Device

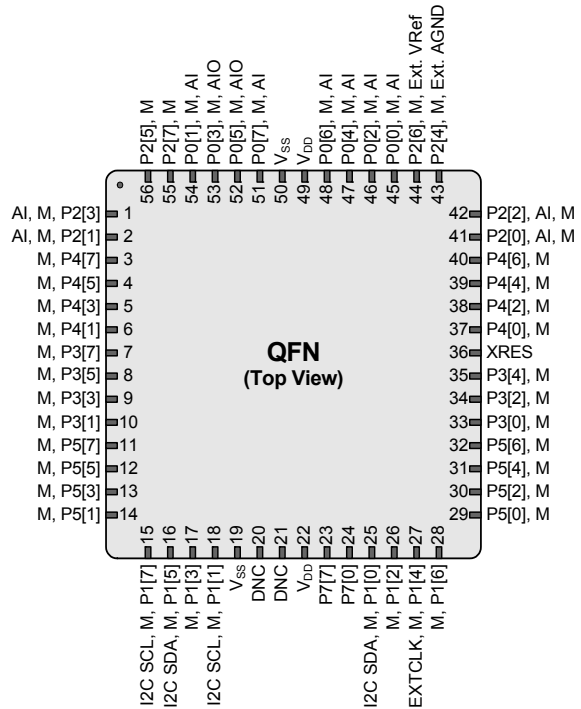

LEGEND A = Analog, I = Input, O = Output, and M = Analog Mux Input.

**Note**

4. These are the ISSP pins, which are not high Z when coming out of reset state. See the *PSoc Technical Reference Manual* for details.



## Registers

This section lists the registers of the automotive CY8C24x94 PSoC device family. For detailed register information, refer to the [PSoC Technical Reference Manual](#).

### Register Conventions

The register conventions specific to this section are listed in the following table.

Convention	Description
R	Read register or bit(s)
W	Write register or bit(s)
L	Logical register or bit(s)
C	Clearable register or bit(s)
#	Access is bit specific

### Register Mapping Tables

The PSoC device has a total register address space of 512 bytes. The register space is referred to as I/O space and is divided into two banks. The XIO bit in the Flag register (CPU\_F) determines which bank the user is currently in. When the XIO bit is set the user is in Bank 1.

**Note** In the following register mapping tables, blank fields are Reserved and should not be accessed.

Register Map Bank 0 Table: User Space

Name	Addr (0,Hex)	Access	Name	Addr (0,Hex)	Access	Name	Addr (0,Hex)	Access	Name	Addr (0,Hex)	Access
PRT0DR	00	RW		40		ASC10CR0	80	RW		C0	
PRT0IE	01	RW		41		ASC10CR1	81	RW		C1	
PRT0GS	02	RW		42		ASC10CR2	82	RW		C2	
PRT0DM2	03	RW		43		ASC10CR3	83	RW		C3	
PRT1DR	04	RW		44		ASD11CR0	84	RW		C4	
PRT1IE	05	RW		45		ASD11CR1	85	RW		C5	
PRT1GS	06	RW		46		ASD11CR2	86	RW		C6	
PRT1DM2	07	RW		47		ASD11CR3	87	RW		C7	
PRT2DR	08	RW		48			88			C8	
PRT2IE	09	RW		49			89			C9	
PRT2GS	0A	RW		4A			8A			CA	
PRT2DM2	0B	RW		4B			8B			CB	
PRT3DR	0C	RW		4C			8C			CC	
PRT3IE	0D	RW		4D			8D			CD	
PRT3GS	0E	RW		4E			8E			CE	
PRT3DM2	0F	RW		4F			8F			CF	
PRT4DR	10	RW		50		ASD20CR0	90	RW	CUR_PP	D0	RW
PRT4IE	11	RW		51		ASD20CR1	91	RW	STK_PP	D1	RW
PRT4GS	12	RW		52		ASD20CR2	92	RW		D2	
PRT4DM2	13	RW		53		ASD20CR3	93	RW	IDX_PP	D3	RW
PRT5DR	14	RW		54		ASC21CR0	94	RW	MVR_PP	D4	RW
PRT5IE	15	RW		55		ASC21CR1	95	RW	MVV_PP	D5	RW
PRT5GS	16	RW		56		ASC21CR2	96	RW	I2C_CFG	D6	RW
PRT5DM2	17	RW		57		ASC21CR3	97	RW	I2C_SCR	D7	#
	18			58			98		I2C_DR	D8	RW
	19			59			99		I2C_MSCR	D9	#
	1A			5A			9A		INT_CLR0	DA	RW
	1B			5B			9B		INT_CLR1	DB	RW
PRT7DR	1C	RW		5C			9C		INT_CLR2	DC	RW
PRT7IE	1D	RW		5D			9D		INT_CLR3	DD	RW
PRT7GS	1E	RW		5E			9E		INT_MSK3	DE	RW
PRT7DM2	1F	RW		5F			9F		INT_MSK2	DF	RW
DBB00DR0	20	#	AMX_IN	60	RW		A0		INT_MSK0	E0	RW
DBB00DR1	21	W	AMUXCFG	61	RW		A1		INT_MSK1	E1	RW
DBB00DR2	22	RW		62			A2		INT_VC	E2	RC
DBB00CR0	23	#	ARF_CR	63	RW		A3		RES_WDT	E3	W
DBB01DR0	24	#	CMP_CR0	64	#		A4		DEC_DH	E4	RC
DBB01DR1	25	W	ASY_CR	65	#		A5		DEC_DL	E5	RC
DBB01DR2	26	RW	CMP_CR1	66	RW		A6		DEC_CR0	E6	RW
DBB01CR0	27	#		67			A7		DEC_CR1	E7	RW
DCB02DR0	28	#		68		MUL1_X	A8	W	MUL0_X	E8	W
DCB02DR1	29	W		69		MUL1_Y	A9	W	MUL0_Y	E9	W
DCB02DR2	2A	RW		6A		MUL1_DH	AA	R	MUL0_DH	EA	R
DCB02CR0	2B	#		6B		MUL1_DL	AB	R	MUL0_DL	EB	R
DCB03DR0	2C	#	TMP_DR0	6C	RW	ACC1_DR1	AC	RW	ACC0_DR1	EC	RW
DCB03DR1	2D	W	TMP_DR1	6D	RW	ACC1_DR0	AD	RW	ACC0_DR0	ED	RW
DCB03DR2	2E	RW	TMP_DR2	6E	RW	ACC1_DR3	AE	RW	ACC0_DR3	EE	RW
DCB03CR0	2F	#	TMP_DR3	6F	RW	ACC1_DR2	AF	RW	ACC0_DR2	EF	RW
	30		ACB00CR3	70	RW	RDI0RI	B0	RW		F0	
	31		ACB00CR0	71	RW	RDI0SYN	B1	RW		F1	
	32		ACB00CR1	72	RW	RDI0IS	B2	RW		F2	
	33		ACB00CR2	73	RW	RDI0LTO	B3	RW		F3	
	34		ACB01CR3	74	RW	RDI0LT1	B4	RW		F4	
	35		ACB01CR0	75	RW	RDI0RO0	B5	RW		F5	
	36		ACB01CR1	76	RW	RDI0RO1	B6	RW		F6	
	37		ACB01CR2	77	RW		B7		CPU_F	F7	RL
	38			78			B8			F8	
	39			79			B9			F9	
	3A			7A			BA			FA	
	3B			7B			BB			FB	
	3C			7C			BC			FC	
	3D			7D			BD		DAC_D	FD	RW
	3E			7E			BE		CPU_SCR1	FE	#
	3F			7F			BF		CPU_SCR0	FF	#

Blank fields are Reserved and should not be accessed.

# Access is bit specific.

Register Map Bank 1 Table: Configuration Space

Name	Addr (1,Hex)	Access	Name	Addr (1,Hex)	Access	Name	Addr (1,Hex)	Access	Name	Addr (1,Hex)	Access
PRT0DM0	00	RW		40		ASC10CR0	80	RW		C0	
PRT0DM1	01	RW		41		ASC10CR1	81	RW		C1	
PRT0IC0	02	RW		42		ASC10CR2	82	RW		C2	
PRT0IC1	03	RW		43		ASC10CR3	83	RW		C3	
PRT1DM0	04	RW		44		ASD11CR0	84	RW		C4	
PRT1DM1	05	RW		45		ASD11CR1	85	RW		C5	
PRT1IC0	06	RW		46		ASD11CR2	86	RW		C6	
PRT1IC1	07	RW		47		ASD11CR3	87	RW		C7	
PRT2DM0	08	RW		48			88			C8	
PRT2DM1	09	RW		49			89			C9	
PRT2IC0	0A	RW		4A			8A			CA	
PRT2IC1	0B	RW		4B			8B			CB	
PRT3DM0	0C	RW		4C			8C			CC	
PRT3DM1	0D	RW		4D			8D			CD	
PRT3IC0	0E	RW		4E			8E			CE	
PRT3IC1	0F	RW		4F			8F			CF	
PRT4DM0	10	RW		50			90		GDI_O_IN	D0	RW
PRT4DM1	11	RW		51		ASD20CR1	91	RW	GDI_E_IN	D1	RW
PRT4IC0	12	RW		52		ASD20CR2	92	RW	GDI_O_OU	D2	RW
PRT4IC1	13	RW		53		ASD20CR3	93	RW	GDI_E_OU	D3	RW
PRT5DM0	14	RW		54		ASC21CR0	94	RW		D4	
PRT5DM1	15	RW		55		ASC21CR1	95	RW		D5	
PRT5IC0	16	RW		56		ASC21CR2	96	RW		D6	
PRT5IC1	17	RW		57		ASC21CR3	97	RW		D7	
	18			58			98		MUX_CR0	D8	RW
	19			59			99		MUX_CR1	D9	RW
	1A			5A			9A		MUX_CR2	DA	RW
	1B			5B			9B		MUX_CR3	DB	RW
PRT7DM0	1C	RW		5C			9C			DC	
PRT7DM1	1D	RW		5D			9D		OSC_GO_EN	DD	RW
PRT7IC0	1E	RW		5E			9E		OSC_CR4	DE	RW
PRT7IC1	1F	RW		5F			9F		OSC_CR3	DF	RW
DBB00FN	20	RW	CLK_CR0	60	RW		A0		OSC_CR0	E0	RW
DBB00IN	21	RW	CLK_CR1	61	RW		A1		OSC_CR1	E1	RW
DBB00OU	22	RW	ABF_CR0	62	RW		A2		OSC_CR2	E2	RW
	23		AMD_CR0	63	RW		A3		VLT_CR	E3	RW
DBB01FN	24	RW	CMP_GO_EN	64	RW		A4		VLT_CMP	E4	R
DBB01IN	25	RW		65			A5			E5	
DBB01OU	26	RW	AMD_CR1	66	RW		A6			E6	
	27		ALT_CR0	67	RW		A7			E7	
DCB02FN	28	RW		68			A8		IMO_TR	E8	W
DCB02IN	29	RW		69			A9		ILO_TR	E9	W
DCB02OU	2A	RW		6A			AA		BDG_TR	EA	RW
	2B			6B			AB		ECO_TR	EB	W
DCB03FN	2C	RW	TMP_DR0	6C	RW		AC		MUX_CR4	EC	RW
DCB03IN	2D	RW	TMP_DR1	6D	RW		AD		MUX_CR5	ED	RW
DCB03OU	2E	RW	TMP_DR2	6E	RW		AE			EE	
	2F		TMP_DR3	6F	RW		AF			EF	
	30		ACB00CR3	70	RW	RDI0RI	B0	RW		F0	
	31		ACB00CR0	71	RW	RDI0SYN	B1	RW		F1	
	32		ACB00CR1	72	RW	RDI0IS	B2	RW		F2	
	33		ACB00CR2	73	RW	RDI0LTO	B3	RW		F3	
	34		ACB01CR3	74	RW	RDI0LT1	B4	RW		F4	
	35		ACB01CR0	75	RW	RDI0RO0	B5	RW		F5	
	36		ACB01CR1	76	RW	RDI0RO1	B6	RW		F6	
	37		ACB01CR2	77	RW		B7		CPU_F	F7	RL
	38			78			B8			F8	
	39			79			B9			F9	
	3A			7A			BA			FA	
	3B			7B			BB			FB	
	3C			7C			BC			FC	
	3D			7D			BD		DAC_CR	FD	RW
	3E			7E			BE		CPU_SCR1	FE	#
	3F			7F			BF		CPU_SCR0	FF	#

Blank fields are Reserved and should not be accessed.

# Access is bit specific.

## Electrical Specifications

This section presents the DC and AC electrical specifications of the automotive CY8C24x94 PSoC device family. For the most up to date electrical specifications, confirm that you have the most recent datasheet by visiting <http://www.cypress.com>.

Specifications are valid for  $-40\text{ }^{\circ}\text{C} \leq T_A \leq 85\text{ }^{\circ}\text{C}$  and  $T_J \leq 100\text{ }^{\circ}\text{C}$ , except where noted.

**Figure 4. Voltage versus CPU Frequency**

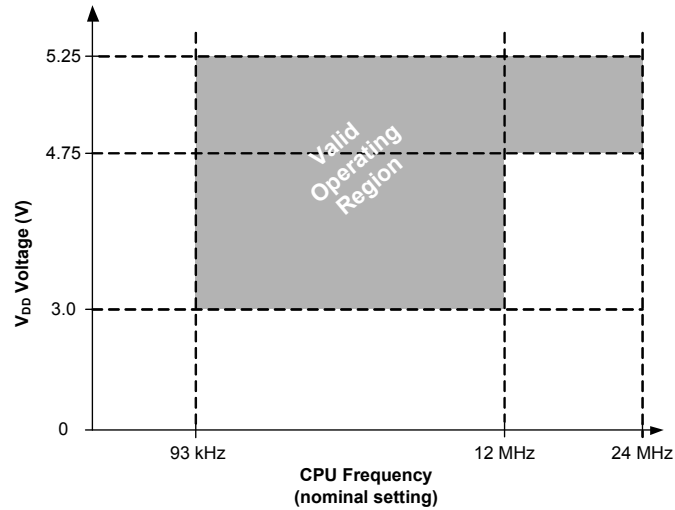

### Absolute Maximum Ratings

Exceeding maximum ratings may shorten the useful life of the device. User guidelines are not tested.

**Table 3. Absolute Maximum Ratings**

Symbol	Description	Min	Typ	Max	Units	Notes
T <sub>STG</sub>	Storage temperature	-55	25	+100	°C	Higher storage temperatures reduce data retention time. Recommended storage temperature is +25 °C ± 25 °C. Time spent in storage at a temperature greater than 65 °C counts toward the Flash <sub>DR</sub> electrical specification in <a href="#">Table 16 on page 26</a> .
T <sub>BAKETEMP</sub>	Bake temperature	-	125	See package label	°C	
t <sub>BAKETIME</sub>	Bake time	See package label	-	72	Hours	
T <sub>A</sub>	Ambient temperature with power applied	-40	-	+85	°C	
V <sub>DD</sub>	Supply voltage on V <sub>DD</sub> relative to V <sub>SS</sub>	-0.5	-	+6.0	V	
V <sub>IO</sub>	DC input voltage	V <sub>SS</sub> - 0.5	-	V <sub>DD</sub> + 0.5	V	
V <sub>IO2</sub>	DC voltage applied to tri-state	V <sub>SS</sub> - 0.5	-	V <sub>DD</sub> + 0.5	V	
I <sub>MIO</sub>	Maximum current into any port pin	-25	-	+50	mA	
I <sub>MAIO</sub>	Maximum current into any port pin configured as analog driver	-50	-	+50	mA	
ESD	Electro static discharge voltage	2000	-	-	V	Human Body Model ESD.
LU	Latch-up current	-	-	200	mA	

### Operating Temperature

**Table 4. Operating Temperature**

Symbol	Description	Min	Typ	Max	Units	Notes
T <sub>A</sub>	Ambient temperature	-40	-	+85	°C	
T <sub>J</sub>	Junction temperature	-40	-	+100	°C	The temperature rise from ambient to junction is package specific. See <a href="#">Table 28 on page 35</a> . The user must limit the power consumption to comply with this requirement.

## DC Electrical Characteristics

### DC Chip Level Specifications

Table 5 lists guaranteed maximum and minimum specifications for the voltage and temperature ranges: 4.75 V to 5.25 V and  $-40\text{ }^{\circ}\text{C} \leq T_A \leq 85\text{ }^{\circ}\text{C}$ , or 3.0 V to 3.6 V and  $-40\text{ }^{\circ}\text{C} \leq T_A \leq 85\text{ }^{\circ}\text{C}$ , respectively. Typical parameters apply to 5 V and 3.3 V at 25 °C and are for design guidance only.

**Table 5. DC Chip-Level Specifications**

Symbol	Description	Min	Typ	Max	Units	Notes
V <sub>DD</sub>	Supply voltage	3.0	–	5.25	V	See DC POR and LVD specifications, <a href="#">Table 15 on page 25</a> .
I <sub>DD5</sub>	Supply current, IMO = 24 MHz, V <sub>DD</sub> = 5 V	–	14	27	mA	Conditions are V <sub>DD</sub> = 5.0 V, T <sub>A</sub> = 25 °C, CPU = 3 MHz, 48 MHz disabled, VC1 = 1.5 MHz, VC2 = 93.75 kHz, VC3 = 93.75 kHz, Analog power = off.
I <sub>DD3</sub>	Supply current, IMO = 24 MHz, V <sub>DD</sub> = 3.3 V	–	8	14	mA	Conditions are V <sub>DD</sub> = 3.3 V, T <sub>A</sub> = 25 °C, CPU = 3 MHz, 48 MHz disabled, VC1 = 1.5 MHz, VC2 = 93.75 kHz, VC3 = 0.367 kHz, Analog power = off.
I <sub>SB</sub>	Sleep <sup>[5]</sup> (mode) current with POR, LVD, sleep timer, and WDT. <sup>[6]</sup>	–	3	6.5	μA	Conditions are with ILO active, V <sub>DD</sub> = 3.3 V, $-40\text{ }^{\circ}\text{C} \leq T_A \leq 55\text{ }^{\circ}\text{C}$ , Analog power = off.
I <sub>SBH</sub>	Sleep (mode) current with POR, LVD, sleep timer, and WDT at high temperature. <sup>[6]</sup>	–	4	25	μA	Conditions are with ILO active, V <sub>DD</sub> = 3.3 V, $55\text{ }^{\circ}\text{C} < T_A \leq 85\text{ }^{\circ}\text{C}$ , Analog power = off.

### Notes

5. **Errata:** When the device is operating at 4.75 V to 5.25 V and the 3.3 V regulator is enabled, a short low pulse may be created on the DP signal line during device wake-up. The 15-20 μs low pulse of the DP line may be interpreted by the host computer as a deattach or the beginning of a wake-up. More details in "Errata" on page 46.
6. Standby current includes all functions (POR, LVD, WDT, sleep timer) needed for reliable system operation. This should be compared with devices that have similar functions enabled.

**DC GPIO Specifications**

The following table lists guaranteed maximum and minimum specifications for the voltage and temperature ranges: 4.75 V to 5.25 V and  $-40\text{ }^{\circ}\text{C} \leq T_A \leq 85\text{ }^{\circ}\text{C}$ , or 3.0 V to 3.6 V and  $-40\text{ }^{\circ}\text{C} \leq T_A \leq 85\text{ }^{\circ}\text{C}$ , respectively. Typical parameters apply to 5 V and 3.3 V at 25 °C and are for design guidance only.

**Table 6. DC GPIO Specifications**

Symbol	Description	Min	Typ	Max	Units	Notes
R <sub>PU</sub>	Pull-up resistor	4	5.6	8	kΩ	
R <sub>PD</sub>	Pull-down resistor	4	5.6	8	kΩ	Also applies to the internal pull-down resistor on the XRES pin
V <sub>OH</sub>	High output level	V <sub>DD</sub> - 1.0	–	–	V	I <sub>OH</sub> = 10 mA, V <sub>DD</sub> = 4.75 V to 5.25 V (8 total loads, 4 on even port pins (for example, P0[2], P1[4]), 4 on odd port pins (for example, P0[3], P1[5])). 80 mA maximum combined I <sub>OH</sub> budget.
V <sub>OL</sub>	Low output level	–	–	0.75	V	I <sub>OL</sub> = 25 mA, V <sub>DD</sub> = 4.75 V to 5.25 V (8 total loads, 4 on even port pins (for example, P0[2], P1[4]), 4 on odd port pins (for example, P0[3], P1[5])). 200 mA maximum combined I <sub>OL</sub> budget.
I <sub>OH</sub>	High level source current	10	–	–	mA	V <sub>OH</sub> ≥ V <sub>DD</sub> - 1.0 V, see the limitations of the total current in the note for V <sub>OH</sub> .
I <sub>OL</sub>	Low level sink current	25	–	–	mA	V <sub>OL</sub> ≤ 0.75 V, see the limitations of the total current in the note for V <sub>OL</sub> .
V <sub>IL</sub>	Input low level	–	–	0.8	V	V <sub>DD</sub> = 3.0 V to 5.25 V.
V <sub>IH</sub>	Input high level	2.1	–	–	V	V <sub>DD</sub> = 3.0 V to 5.25 V.
V <sub>H</sub>	Input hysteresis	–	60	–	mV	
I <sub>IL</sub>	Input leakage (absolute value)	–	1	–	nA	Gross tested to 1 μA.
C <sub>IN</sub>	Capacitive load on pins as input	–	3.5	10	pF	Package and pin dependent. T <sub>A</sub> = 25 °C.
C <sub>OUT</sub>	Capacitive load on pins as output	–	3.5	10	pF	Package and pin dependent. T <sub>A</sub> = 25 °C.

DC Operational Amplifier Specifications

Table 7 and Table 8 on page 17 list the guaranteed maximum and minimum specifications for the voltage and temperature ranges: 4.75 V to 5.25 V and  $-40\text{ }^{\circ}\text{C} \leq T_A \leq 85\text{ }^{\circ}\text{C}$ , or 3.0 V to 3.6 V and  $-40\text{ }^{\circ}\text{C} \leq T_A \leq 85\text{ }^{\circ}\text{C}$ , respectively. Typical parameters apply to 5 V and 3.3 V at 25 °C and are for design guidance only.

The Operational Amplifier is a component of both the Analog Continuous Time (CT) PSoC blocks and the Analog Switched Capacitor (SC) PSoC blocks. The guaranteed specifications are measured in the Analog Continuous Time PSoC block.

Table 7. 5-V DC Operational Amplifier Specifications

Symbol	Description	Min	Typ	Max	Units	Notes
V <sub>OSOA</sub>	Input offset voltage (absolute value)	–	1.6	10	mV	
	Power = low, Opamp bias = high	–	1.3	8	mV	
	Power = medium, Opamp bias = high	–	1.2	7.5	mV	
TCV <sub>OSOA</sub>	Average input offset voltage Drift	–	7.0	35.0	μV/°C	
I <sub>EBOA</sub>	Input leakage current (Port 0 Analog Pins)	–	20	–	pA	Gross tested to 1 μA.
C <sub>INOA</sub>	Input capacitance (Port 0 Analog Pins)	–	4.5	9.5	pF	Package and pin dependent. T <sub>A</sub> = 25 °C.
V <sub>CMOA</sub>	Common Mode Voltage Range	0.0	–	V <sub>DD</sub>	V	The common-mode input voltage range is measured through an analog output buffer. The specification includes the limitations imposed by the characteristics of the analog output buffer.
	All cases, except highest	0.5	–	V <sub>DD</sub> – 0.5	V	
G <sub>OLOA</sub>	Open loop gain	60	–	–	dB	Specification is applicable at high power. For all other bias modes (except high power, high Opamp bias), minimum is 60 dB.
	Power = low, Opamp bias = high	60	–	–	dB	
	Power = medium, Opamp bias = high	80	–	–	dB	
V <sub>OHIGHOA</sub>	High output voltage swing (internal signals)	V <sub>DD</sub> – 0.2	–	–	V	
	Power = low, Opamp bias = high	V <sub>DD</sub> – 0.2	–	–	V	
	Power = medium, Opamp bias = high	V <sub>DD</sub> – 0.5	–	–	V	
V <sub>OLOWOA</sub>	Low output voltage swing (internal signals)	–	–	0.2	V	
	Power = low, Opamp bias = high	–	–	0.2	V	
	Power = medium, Opamp bias = high	–	–	0.5	V	
I <sub>SOA</sub>	Supply current (including associated AGND buffer)	–	400	800	μA	
	Power = low, Opamp bias = low	–	500	900	μA	
	Power = low, Opamp bias = high	–	800	1000	μA	
	Power = medium, Opamp bias = low	–	1200	1600	μA	
	Power = medium, Opamp bias = high	–	2400	3200	μA	
	Power = high, Opamp bias = low	–	4600	6400	μA	
PSRR <sub>OA</sub>	Supply voltage rejection ratio	65	80	–	dB	V <sub>SS</sub> ≤ V <sub>IN</sub> ≤ (V <sub>DD</sub> – 2.25 V) or (V <sub>DD</sub> – 1.25 V) ≤ V <sub>IN</sub> ≤ V <sub>DD</sub> .



**Table 8. 3.3-V DC Operational Amplifier Specifications**

Symbol	Description	Min	Typ	Max	Units	Notes
$V_{OSO A}$	Input offset voltage (absolute value)					Power = high, Opamp bias = high setting is not allowed for 3.3 V $V_{DD}$ operation
	Power = low, Opamp bias = high	–	1.65	10	mV	
	Power = medium, Opamp bias = high	–	1.32	8	mV	
	Power = high, Opamp bias = high	–	–	–	mV	
$TCV_{OSO A}$	Average input offset voltage drift	–	7.0	35.0	$\mu V/^\circ C$	
$I_{EBO A}$	Input leakage current (Port 0 analog pins)	–	20	–	pA	Gross tested to 1 $\mu A$ .
$C_{INO A}$	Input capacitance (Port 0 analog pins)	–	4.5	9.5	pF	Package and pin dependent. $T_A = 25^\circ C$ .
$V_{CMO A}$	Common mode voltage range	0.2	–	$V_{DD} - 0.2$	V	The common-mode input voltage range is measured through an analog output buffer. The specification includes the limitations imposed by the characteristics of the analog output buffer.
$G_{OLO A}$	Open loop gain					Specification is applicable at low Opamp bias. For high Opamp bias mode (except high power, high Opamp bias), minimum is 60 dB.
	Power = low, Opamp bias = low	60	–	–	dB	
	Power = medium, Opamp bias = low	60	–	–	dB	
$V_{OHIGHO A}$	High output voltage swing (internal signals)					
	Power = low, Opamp bias = low	$V_{DD} - 0.2$	–	–	V	
	Power = medium, Opamp bias = low	$V_{DD} - 0.2$	–	–	V	
$V_{OLOWO A}$	Low output voltage swing (internal signals)					
	Power = low, Opamp bias = low	–	–	0.2	V	
	Power = medium, Opamp bias = low	–	–	0.2	V	
$I_{SO A}$	Supply current (including associated AGND buffer)					Power = high, Opamp bias = high setting is not allowed for 3.3 V $V_{DD}$ operation
	Power = low, Opamp bias = low	–	400	800	$\mu A$	
	Power = low, Opamp bias = high	–	500	900	$\mu A$	
	Power = medium, Opamp bias = low	–	800	1000	$\mu A$	
	Power = medium, Opamp bias = high	–	1200	1600	$\mu A$	
	Power = high, Opamp bias = low	–	2400	3200	$\mu A$	
Power = high, Opamp bias = high	–	–	–	$\mu A$		
$PSRR_{O A}$	Supply voltage rejection ratio	65	80	–	dB	$V_{SS} \leq V_{IN} \leq (V_{DD} - 2.25)$ or $(V_{DD} - 1.25 V) \leq V_{IN} \leq V_{DD}$

**DC Low Power Comparator Specifications**

Table 9 lists guaranteed maximum and minimum specifications for the voltage and temperature ranges: 4.75 V to 5.25 V and  $-40^\circ C \leq T_A \leq 85^\circ C$ , or 3.0 V to 3.6 V and  $-40^\circ C \leq T_A \leq 85^\circ C$ , respectively. Typical parameters apply to 5 V at  $25^\circ C$  and are for design guidance only.

**Table 9. DC Low Power Comparator Specifications**

Symbol	Description	Min	Typ	Max	Units	Notes
$V_{REFLPC}$	Low power comparator (LPC) reference voltage range	0.2	–	$V_{DD} - 1.0$	V	
$I_{SLPC}$	LPC supply current	–	10	55	$\mu A$	
$V_{OSLPC}$	LPC voltage offset	–	2.5	55	mV	

**DC Analog Output Buffer Specifications**

Table 10 and Table 11 on page 19 list the guaranteed maximum and minimum specifications for the voltage and temperature ranges: 4.75 V to 5.25 V and  $-40\text{ }^{\circ}\text{C} \leq T_A \leq 85\text{ }^{\circ}\text{C}$ , or 3.0 V to 3.6 V and  $-40\text{ }^{\circ}\text{C} \leq T_A \leq 85\text{ }^{\circ}\text{C}$ , respectively. Typical parameters apply to 5 V and 3.3 V at 25 °C and are for design guidance only.

**Table 10. 5-V DC Analog Output Buffer Specifications**

Symbol	Description	Min	Typ	Max	Units	Notes
$V_{OSOB}$	Input offset voltage (absolute value)	–	3	12	mV	
$TCV_{OSOB}$	Average input offset voltage drift	–	+6	–	$\mu\text{V}/^{\circ}\text{C}$	
$V_{CMOB}$	Common mode input voltage range	0.5	–	$V_{DD} - 1.0$	V	
$R_{OUTOB}$	Output resistance					
	Power = low Power = high	– –	0.6 0.6	– –	$\Omega$ $\Omega$	
$V_{OHIGHOB}$	High output voltage swing (load = 32 $\Omega$ to $V_{DD}/2$ )					
	Power = low	$0.5 \times V_{DD} + 1.1$	–	–	V	
	Power = high	$0.5 \times V_{DD} + 1.1$	–	–	V	
$V_{OLOWOB}$	Low output voltage swing (load = 32 $\Omega$ to $V_{DD}/2$ )					
	Power = low	–	–	$0.5 \times V_{DD} - 1.3$	V	
	Power = high	–	–	$0.5 \times V_{DD} - 1.3$	V	
$I_{SOB}$	Supply current including opamp bias cell (no load)					
	Power = low	–	1.1	5.1	mA	
	Power = high	–	2.6	8.8	mA	
$PSRR_{OB}$	Supply voltage rejection ratio	53	64	–	dB	$(0.5 \times V_{DD} - 1.3) \leq V_{OUT} \leq (V_{DD} - 2.3)$ .
$C_L$	Load capacitance	–	–	200	pF	This specification applies to the external circuit that is being driven by the analog output buffer.

**Table 11. 3.3-V DC Analog Output Buffer Specifications**

Symbol	Description	Min	Typ	Max	Units	Notes
$V_{OSOB}$	Input offset voltage (absolute value)	–	3	12	mV	
$TCV_{OSOB}$	Average input offset voltage drift	–	+6	–	$\mu V/^{\circ}C$	
$V_{CMOB}$	Common mode input voltage range	0.5	–	$V_{DD} - 1.0$	V	
$R_{OUTOB}$	Output resistance					
	Power = low	–	1	–	$\Omega$	
	Power = high	–	1	–	$\Omega$	
$V_{OHIGHOB}$	High output voltage swing (load = 1 K $\Omega$ to $V_{DD}/2$ )					
	Power = low	$0.5 \times V_{DD} + 1.0$	–	–	V	
	Power = high	$0.5 \times V_{DD} + 1.0$	–	–	V	
$V_{OLOWOB}$	Low output voltage swing (load = 1 K $\Omega$ to $V_{DD}/2$ )					
	Power = low	–	–	$0.5 \times V_{DD} - 1.0$	V	
	Power = high	–	–	$0.5 \times V_{DD} - 1.0$	V	
$I_{SOB}$	Supply current including opamp bias cell (no load)					
	Power = low	–	0.8	2.0	mA	
	Power = high	–	2.0	4.3	mA	
$PSRR_{OB}$	Supply voltage rejection ratio	34	64	–	dB	$(0.5 \times V_{DD} - 1.0) \leq V_{OUT} \leq (0.5 \times V_{DD} + 0.9)$ .
$C_L$	Load capacitance	–	–	200	pF	This specification applies to the external circuit that is being driven by the analog output buffer.

DC Analog Reference Specifications

Table 12 and Table 13 on page 23 list the guaranteed maximum and minimum specifications for the voltage and temperature ranges: 4.75 V to 5.25 V and  $-40\text{ }^{\circ}\text{C} \leq T_A \leq 85\text{ }^{\circ}\text{C}$ , or 3.0 V to 3.6 V and  $-40\text{ }^{\circ}\text{C} \leq T_A \leq 85\text{ }^{\circ}\text{C}$ , respectively. Typical parameters apply to 5 V and 3.3 V at 25 °C. These are for design guidance only.

The guaranteed specifications are measured through the analog CT PSoC blocks. The power levels for AGND refer to the power of the analog CT PSoC block. The power levels for RefHi and RefLo refer to the Analog Reference Control register. The limits stated for AGND include the offset error of the AGND buffer local to the analog CT PSoC block. Reference control power is high.

**Note** Avoid using P2[4] for digital signaling when using an analog resource that depends on the analog reference. Some coupling of the digital signal may appear on the AGND.

Table 12. 5-V DC Analog Reference Specifications

Reference ARF_CR [5:3]	Reference Power Settings	Symbol	Reference	Description	Min	Typ	Max	Units
0b000	RefPower = high Opamp bias = high	V <sub>REFHI</sub>	Ref High	V <sub>DD</sub> /2 + Bandgap	V <sub>DD</sub> /2 + 1.229	V <sub>DD</sub> /2 + 1.290	V <sub>DD</sub> /2 + 1.346	V
		V <sub>AGND</sub>	AGND	V <sub>DD</sub> /2	V <sub>DD</sub> /2 - 0.038	V <sub>DD</sub> /2	V <sub>DD</sub> /2 + 0.040	V
		V <sub>REFLO</sub>	Ref Low	V <sub>DD</sub> /2 - Bandgap	V <sub>DD</sub> /2 - 1.356	V <sub>DD</sub> /2 - 1.295	V <sub>DD</sub> /2 - 1.218	V
	RefPower = high Opamp bias = low	V <sub>REFHI</sub>	Ref High	V <sub>DD</sub> /2 + Bandgap	V <sub>DD</sub> /2 + 1.220	V <sub>DD</sub> /2 + 1.292	V <sub>DD</sub> /2 + 1.348	V
		V <sub>AGND</sub>	AGND	V <sub>DD</sub> /2	V <sub>DD</sub> /2 - 0.036	V <sub>DD</sub> /2	V <sub>DD</sub> /2 + 0.036	V
		V <sub>REFLO</sub>	Ref Low	V <sub>DD</sub> /2 - Bandgap	V <sub>DD</sub> /2 - 1.357	V <sub>DD</sub> /2 - 1.297	V <sub>DD</sub> /2 - 1.225	V
	RefPower = medium Opamp bias = high	V <sub>REFHI</sub>	Ref High	V <sub>DD</sub> /2 + Bandgap	V <sub>DD</sub> /2 + 1.221	V <sub>DD</sub> /2 + 1.293	V <sub>DD</sub> /2 + 1.351	V
		V <sub>AGND</sub>	AGND	V <sub>DD</sub> /2	V <sub>DD</sub> /2 - 0.036	V <sub>DD</sub> /2	V <sub>DD</sub> /2 + 0.036	V
		V <sub>REFLO</sub>	Ref Low	V <sub>DD</sub> /2 - Bandgap	V <sub>DD</sub> /2 - 1.357	V <sub>DD</sub> /2 - 1.298	V <sub>DD</sub> /2 - 1.228	V
	RefPower = medium Opamp bias = low	V <sub>REFHI</sub>	Ref High	V <sub>DD</sub> /2 + Bandgap	V <sub>DD</sub> /2 + 1.219	V <sub>DD</sub> /2 + 1.293	V <sub>DD</sub> /2 + 1.353	V
		V <sub>AGND</sub>	AGND	V <sub>DD</sub> /2	V <sub>DD</sub> /2 - 0.037	V <sub>DD</sub> /2 - 0.001	V <sub>DD</sub> /2 + 0.036	V
		V <sub>REFLO</sub>	Ref Low	V <sub>DD</sub> /2 - Bandgap	V <sub>DD</sub> /2 - 1.359	V <sub>DD</sub> /2 - 1.299	V <sub>DD</sub> /2 - 1.229	V
0b001	RefPower = high Opamp bias = high	V <sub>REFHI</sub>	Ref High	P2[4]+P2[6] (P2[4] = V <sub>DD</sub> /2, P2[6] = 1.3 V)	P2[4] + P2[6] - 0.092	P2[4] + P2[6] - 0.011	P2[4] + P2[6] + 0.064	V
		V <sub>AGND</sub>	AGND	P2[4]	P2[4]	P2[4]	P2[4]	-
		V <sub>REFLO</sub>	Ref Low	P2[4]-P2[6] (P2[4] = V <sub>DD</sub> /2, P2[6] = 1.3 V)	P2[4] - P2[6] - 0.031	P2[4] - P2[6] + 0.007	P2[4] - P2[6] + 0.056	V
	RefPower = high Opamp bias = low	V <sub>REFHI</sub>	Ref High	P2[4]+P2[6] (P2[4] = V <sub>DD</sub> /2, P2[6] = 1.3 V)	P2[4] + P2[6] - 0.078	P2[4] + P2[6] - 0.008	P2[4] + P2[6] + 0.063	V
		V <sub>AGND</sub>	AGND	P2[4]	P2[4]	P2[4]	P2[4]	-
		V <sub>REFLO</sub>	Ref Low	P2[4]-P2[6] (P2[4] = V <sub>DD</sub> /2, P2[6] = 1.3 V)	P2[4] - P2[6] - 0.031	P2[4] - P2[6] + 0.004	P2[4] - P2[6] + 0.043	V
	RefPower = medium Opamp bias = high	V <sub>REFHI</sub>	Ref High	P2[4]+P2[6] (P2[4] = V <sub>DD</sub> /2, P2[6] = 1.3 V)	P2[4] + P2[6] - 0.073	P2[4] + P2[6] - 0.006	P2[4] + P2[6] + 0.062	V
		V <sub>AGND</sub>	AGND	P2[4]	P2[4]	P2[4]	P2[4]	-
		V <sub>REFLO</sub>	Ref Low	P2[4]-P2[6] (P2[4] = V <sub>DD</sub> /2, P2[6] = 1.3 V)	P2[4] - P2[6] - 0.032	P2[4] - P2[6] + 0.003	P2[4] - P2[6] + 0.038	V
	RefPower = medium Opamp bias = low	V <sub>REFHI</sub>	Ref High	P2[4]+P2[6] (P2[4] = V <sub>DD</sub> /2, P2[6] = 1.3 V)	P2[4] + P2[6] - 0.073	P2[4] + P2[6] - 0.006	P2[4] + P2[6] + 0.062	V
		V <sub>AGND</sub>	AGND	P2[4]	P2[4]	P2[4]	P2[4]	-
		V <sub>REFLO</sub>	Ref Low	P2[4]-P2[6] (P2[4] = V <sub>DD</sub> /2, P2[6] = 1.3 V)	P2[4] - P2[6] - 0.034	P2[4] - P2[6] + 0.002	P2[4] - P2[6] + 0.037	V

Table 12. 5-V DC Analog Reference Specifications (continued)

Reference ARF_CR [5:3]	Reference Power Settings	Symbol	Reference	Description	Min	Typ	Max	Units
0b010	RefPower = high Opamp bias = high	V <sub>REFHI</sub>	Ref High	V <sub>DD</sub>	V <sub>DD</sub> - 0.037	V <sub>DD</sub> - 0.007	V <sub>DD</sub>	V
		V <sub>AGND</sub>	AGND	V <sub>DD</sub> /2	V <sub>DD</sub> /2 - 0.036	V <sub>DD</sub> /2 - 0.001	V <sub>DD</sub> /2 + 0.036	V
		V <sub>REFLO</sub>	Ref Low	V <sub>SS</sub>	V <sub>SS</sub>	V <sub>SS</sub> + 0.005	V <sub>SS</sub> + 0.029	V
	RefPower = high Opamp bias = low	V <sub>REFHI</sub>	Ref High	V <sub>DD</sub>	V <sub>DD</sub> - 0.034	V <sub>DD</sub> - 0.006	V <sub>DD</sub>	V
		V <sub>AGND</sub>	AGND	V <sub>DD</sub> /2	V <sub>DD</sub> /2 - 0.036	V <sub>DD</sub> /2 - 0.001	V <sub>DD</sub> /2 + 0.035	V
		V <sub>REFLO</sub>	Ref Low	V <sub>SS</sub>	V <sub>SS</sub>	V <sub>SS</sub> + 0.004	V <sub>SS</sub> + 0.024	V
	RefPower = medium Opamp bias = high	V <sub>REFHI</sub>	Ref High	V <sub>DD</sub>	V <sub>DD</sub> - 0.032	V <sub>DD</sub> - 0.005	V <sub>DD</sub>	V
		V <sub>AGND</sub>	AGND	V <sub>DD</sub> /2	V <sub>DD</sub> /2 - 0.036	V <sub>DD</sub> /2 - 0.001	V <sub>DD</sub> /2 + 0.035	V
		V <sub>REFLO</sub>	Ref Low	V <sub>SS</sub>	V <sub>SS</sub>	V <sub>SS</sub> + 0.003	V <sub>SS</sub> + 0.022	V
RefPower = medium Opamp bias = low	V <sub>REFHI</sub>	Ref High	V <sub>DD</sub>	V <sub>DD</sub> - 0.031	V <sub>DD</sub> - 0.005	V <sub>DD</sub>	V	
	V <sub>AGND</sub>	AGND	V <sub>DD</sub> /2	V <sub>DD</sub> /2 - 0.037	V <sub>DD</sub> /2 - 0.001	V <sub>DD</sub> /2 + 0.035	V	
	V <sub>REFLO</sub>	Ref Low	V <sub>SS</sub>	V <sub>SS</sub>	V <sub>SS</sub> + 0.003	V <sub>SS</sub> + 0.020	V	
0b011	RefPower = high Opamp bias = high	V <sub>REFHI</sub>	Ref High	3 × Bandgap	3.760	3.884	4.006	V
		V <sub>AGND</sub>	AGND	2 × Bandgap	2.522	2.593	2.669	V
		V <sub>REFLO</sub>	Ref Low	Bandgap	1.252	1.299	1.342	V
	RefPower = high Opamp bias = low	V <sub>REFHI</sub>	Ref High	3 × Bandgap	3.766	3.887	4.010	V
		V <sub>AGND</sub>	AGND	2 × Bandgap	2.523	2.594	2.670	V
		V <sub>REFLO</sub>	Ref Low	Bandgap	1.252	1.297	1.342	V
	RefPower = medium Opamp bias = high	V <sub>REFHI</sub>	Ref High	3 × Bandgap	3.769	3.888	4.013	V
		V <sub>AGND</sub>	AGND	2 × Bandgap	2.523	2.594	2.671	V
		V <sub>REFLO</sub>	Ref Low	Bandgap	1.251	1.296	1.343	V
RefPower = medium Opamp bias = low	V <sub>REFHI</sub>	Ref High	3 × Bandgap	3.769	3.889	4.015	V	
	V <sub>AGND</sub>	AGND	2 × Bandgap	2.523	2.595	2.671	V	
	V <sub>REFLO</sub>	Ref Low	Bandgap	1.251	1.296	1.344	V	
0b100	RefPower = high Opamp bias = high	V <sub>REFHI</sub>	Ref High	2 × Bandgap + P2[6] (P2[6] = 1.3 V)	2.483 - P2[6]	2.582 - P2[6]	2.674 - P2[6]	V
		V <sub>AGND</sub>	AGND	2 × Bandgap	2.522	2.593	2.669	V
		V <sub>REFLO</sub>	Ref Low	2 × Bandgap - P2[6] (P2[6] = 1.3 V)	2.524 - P2[6]	2.600 - P2[6]	2.676 - P2[6]	V
	RefPower = high Opamp bias = low	V <sub>REFHI</sub>	Ref High	2 × Bandgap + P2[6] (P2[6] = 1.3 V)	2.490 - P2[6]	2.586 - P2[6]	2.679 - P2[6]	V
		V <sub>AGND</sub>	AGND	2 × Bandgap	2.523	2.594	2.669	V
		V <sub>REFLO</sub>	Ref Low	2 × Bandgap - P2[6] (P2[6] = 1.3 V)	2.523 - P2[6]	2.598 - P2[6]	2.675 - P2[6]	V
	RefPower = medium Opamp bias = high	V <sub>REFHI</sub>	Ref High	2 × Bandgap + P2[6] (P2[6] = 1.3 V)	2.493 - P2[6]	2.588 - P2[6]	2.682 - P2[6]	V
		V <sub>AGND</sub>	AGND	2 × Bandgap	2.523	2.594	2.670	V
		V <sub>REFLO</sub>	Ref Low	2 × Bandgap - P2[6] (P2[6] = 1.3 V)	2.523 - P2[6]	2.597 - P2[6]	2.675 - P2[6]	V
RefPower = medium Opamp bias = low	V <sub>REFHI</sub>	Ref High	2 × Bandgap + P2[6] (P2[6] = 1.3 V)	2.494 - P2[6]	2.589 - P2[6]	2.685 - P2[6]	V	
	V <sub>AGND</sub>	AGND	2 × Bandgap	2.523	2.595	2.671	V	
	V <sub>REFLO</sub>	Ref Low	2 × Bandgap - P2[6] (P2[6] = 1.3 V)	2.522 - P2[6]	2.596 - P2[6]	2.676 - P2[6]	V	

Table 12. 5-V DC Analog Reference Specifications (continued)

Reference ARF_CR [5:3]	Reference Power Settings	Symbol	Reference	Description	Min	Typ	Max	Units
0b101	RefPower = high Opamp bias = high	V <sub>REFHI</sub>	Ref High	P2[4] + Bandgap (P2[4] = V <sub>DD</sub> /2)	P2[4] + 1.218	P2[4] + 1.291	P2[4] + 1.354	V
		V <sub>AGND</sub>	AGND	P2[4]	P2[4]	P2[4]	P2[4]	–
		V <sub>REFLO</sub>	Ref Low	P2[4] – Bandgap (P2[4] = V <sub>DD</sub> /2)	P2[4] – 1.335	P2[4] – 1.294	P2[4] – 1.237	V
	RefPower = high Opamp bias = low	V <sub>REFHI</sub>	Ref High	P2[4] + Bandgap (P2[4] = V <sub>DD</sub> /2)	P2[4] + 1.221	P2[4] + 1.293	P2[4] + 1.358	V
		V <sub>AGND</sub>	AGND	P2[4]	P2[4]	P2[4]	P2[4]	–
		V <sub>REFLO</sub>	Ref Low	P2[4] – Bandgap (P2[4] = V <sub>DD</sub> /2)	P2[4] – 1.337	P2[4] – 1.297	P2[4] – 1.243	V
	RefPower = medium Opamp bias = high	V <sub>REFHI</sub>	Ref High	P2[4] + Bandgap (P2[4] = V <sub>DD</sub> /2)	P2[4] + 1.222	P2[4] + 1.294	P2[4] + 1.360	V
		V <sub>AGND</sub>	AGND	P2[4]	P2[4]	P2[4]	P2[4]	–
		V <sub>REFLO</sub>	Ref Low	P2[4] – Bandgap (P2[4] = V <sub>DD</sub> /2)	P2[4] – 1.338	P2[4] – 1.298	P2[4] – 1.245	V
	RefPower = medium Opamp bias = low	V <sub>REFHI</sub>	Ref High	P2[4] + Bandgap (P2[4] = V <sub>DD</sub> /2)	P2[4] + 1.221	P2[4] + 1.294	P2[4] + 1.362	V
		V <sub>AGND</sub>	AGND	P2[4]	P2[4]	P2[4]	P2[4]	–
		V <sub>REFLO</sub>	Ref Low	P2[4] – Bandgap (P2[4] = V <sub>DD</sub> /2)	P2[4] – 1.340	P2[4] – 1.298	P2[4] – 1.245	V
0b110	RefPower = high Opamp bias = high	V <sub>REFHI</sub>	Ref High	2 × Bandgap	2.513	2.593	2.672	V
		V <sub>AGND</sub>	AGND	Bandgap	1.264	1.302	1.340	V
		V <sub>REFLO</sub>	Ref Low	V <sub>SS</sub>	V <sub>SS</sub>	V <sub>SS</sub> + 0.008	V <sub>SS</sub> + 0.038	V
	RefPower = high Opamp bias = low	V <sub>REFHI</sub>	Ref High	2 × Bandgap	2.514	2.593	2.674	V
		V <sub>AGND</sub>	AGND	Bandgap	1.264	1.301	1.340	V
		V <sub>REFLO</sub>	Ref Low	V <sub>SS</sub>	V <sub>SS</sub>	V <sub>SS</sub> + 0.005	V <sub>SS</sub> + 0.028	V
	RefPower = medium Opamp bias = high	V <sub>REFHI</sub>	Ref High	2 × Bandgap	2.514	2.593	2.676	V
		V <sub>AGND</sub>	AGND	Bandgap	1.264	1.301	1.340	V
		V <sub>REFLO</sub>	Ref Low	V <sub>SS</sub>	V <sub>SS</sub>	V <sub>SS</sub> + 0.004	V <sub>SS</sub> + 0.024	V
	RefPower = medium Opamp bias = low	V <sub>REFHI</sub>	Ref High	2 × Bandgap	2.514	2.593	2.677	V
		V <sub>AGND</sub>	AGND	Bandgap	1.264	1.300	1.340	V
		V <sub>REFLO</sub>	Ref Low	V <sub>SS</sub>	V <sub>SS</sub>	V <sub>SS</sub> + 0.003	V <sub>SS</sub> + 0.021	V
0b111	RefPower = high Opamp bias = high	V <sub>REFHI</sub>	Ref High	3.2 × Bandgap	4.028	4.144	4.242	V
		V <sub>AGND</sub>	AGND	1.6 × Bandgap	2.028	2.076	2.125	V
		V <sub>REFLO</sub>	Ref Low	V <sub>SS</sub>	V <sub>SS</sub>	V <sub>SS</sub> + 0.008	V <sub>SS</sub> + 0.034	V
	RefPower = high Opamp bias = low	V <sub>REFHI</sub>	Ref High	3.2 × Bandgap	4.032	4.142	4.245	V
		V <sub>AGND</sub>	AGND	1.6 × Bandgap	2.029	2.076	2.126	V
		V <sub>REFLO</sub>	Ref Low	V <sub>SS</sub>	V <sub>SS</sub>	V <sub>SS</sub> + 0.005	V <sub>SS</sub> + 0.025	V
	RefPower = medium Opamp bias = high	V <sub>REFHI</sub>	Ref High	3.2 × Bandgap	4.034	4.143	4.247	V
		V <sub>AGND</sub>	AGND	1.6 × Bandgap	2.029	2.076	2.126	V
		V <sub>REFLO</sub>	Ref Low	V <sub>SS</sub>	V <sub>SS</sub>	V <sub>SS</sub> + 0.004	V <sub>SS</sub> + 0.021	V
	RefPower = medium Opamp bias = low	V <sub>REFHI</sub>	Ref High	3.2 × Bandgap	4.036	4.144	4.249	V
		V <sub>AGND</sub>	AGND	1.6 × Bandgap	2.029	2.076	2.126	V
		V <sub>REFLO</sub>	Ref Low	V <sub>SS</sub>	V <sub>SS</sub>	V <sub>SS</sub> + 0.003	V <sub>SS</sub> + 0.019	V

Table 13. 3.3-V DC Analog Reference Specifications

Reference ARF_CR [5:3]	Reference Power Settings	Symbol	Reference	Description	Min	Typ	Max	Units
0b000	RefPower = high Opamp bias = high	V <sub>REFHI</sub>	Ref High	V <sub>DD</sub> /2 + Bandgap	V <sub>DD</sub> /2 + 1.200	V <sub>DD</sub> /2 + 1.290	V <sub>DD</sub> /2 + 1.365	V
		V <sub>AGND</sub>	AGND	V <sub>DD</sub> /2	V <sub>DD</sub> /2 - 0.030	V <sub>DD</sub> /2	V <sub>DD</sub> /2 + 0.034	V
		V <sub>REFLO</sub>	Ref Low	V <sub>DD</sub> /2 - Bandgap	V <sub>DD</sub> /2 - 1.346	V <sub>DD</sub> /2 - 1.292	V <sub>DD</sub> /2 - 1.208	V
	RefPower = high Opamp bias = low	V <sub>REFHI</sub>	Ref High	V <sub>DD</sub> /2 + Bandgap	V <sub>DD</sub> /2 + 1.196	V <sub>DD</sub> /2 + 1.292	V <sub>DD</sub> /2 + 1.374	V
		V <sub>AGND</sub>	AGND	V <sub>DD</sub> /2	V <sub>DD</sub> /2 - 0.029	V <sub>DD</sub> /2	V <sub>DD</sub> /2 + 0.031	V
		V <sub>REFLO</sub>	Ref Low	V <sub>DD</sub> /2 - Bandgap	V <sub>DD</sub> /2 - 1.349	V <sub>DD</sub> /2 - 1.295	V <sub>DD</sub> /2 - 1.227	V
	RefPower = medium Opamp bias = high	V <sub>REFHI</sub>	Ref High	V <sub>DD</sub> /2 + Bandgap	V <sub>DD</sub> /2 + 1.204	V <sub>DD</sub> /2 + 1.293	V <sub>DD</sub> /2 + 1.369	V
		V <sub>AGND</sub>	AGND	V <sub>DD</sub> /2	V <sub>DD</sub> /2 - 0.030	V <sub>DD</sub> /2	V <sub>DD</sub> /2 + 0.030	V
		V <sub>REFLO</sub>	Ref Low	V <sub>DD</sub> /2 - Bandgap	V <sub>DD</sub> /2 - 1.351	V <sub>DD</sub> /2 - 1.297	V <sub>DD</sub> /2 - 1.229	V
	RefPower = medium Opamp bias = low	V <sub>REFHI</sub>	Ref High	V <sub>DD</sub> /2 + Bandgap	V <sub>DD</sub> /2 + 1.189	V <sub>DD</sub> /2 + 1.294	V <sub>DD</sub> /2 + 1.384	V
		V <sub>AGND</sub>	AGND	V <sub>DD</sub> /2	V <sub>DD</sub> /2 - 0.032	V <sub>DD</sub> /2	V <sub>DD</sub> /2 + 0.029	V
		V <sub>REFLO</sub>	Ref Low	V <sub>DD</sub> /2 - Bandgap	V <sub>DD</sub> /2 - 1.353	V <sub>DD</sub> /2 - 1.297	V <sub>DD</sub> /2 - 1.230	V
0b001	RefPower = high Opamp bias = high	V <sub>REFHI</sub>	Ref High	P2[4]+P2[6] (P2[4] = V <sub>DD</sub> /2, P2[6] = 0.5 V)	P2[4] + P2[6] - 0.105	P2[4] + P2[6] - 0.008	P2[4] + P2[6] + 0.095	V
		V <sub>AGND</sub>	AGND	P2[4]	P2[4]	P2[4]	P2[4]	-
		V <sub>REFLO</sub>	Ref Low	P2[4]-P2[6] (P2[4] = V <sub>DD</sub> /2, P2[6] = 0.5 V)	P2[4] - P2[6] - 0.035	P2[4] - P2[6] + 0.006	P2[4] - P2[6] + 0.053	V
	RefPower = high Opamp bias = low	V <sub>REFHI</sub>	Ref High	P2[4]+P2[6] (P2[4] = V <sub>DD</sub> /2, P2[6] = 0.5 V)	P2[4] + P2[6] - 0.094	P2[4] + P2[6] - 0.005	P2[4] + P2[6] + 0.073	V
		V <sub>AGND</sub>	AGND	P2[4]	P2[4]	P2[4]	P2[4]	-
		V <sub>REFLO</sub>	Ref Low	P2[4]-P2[6] (P2[4] = V <sub>DD</sub> /2, P2[6] = 0.5 V)	P2[4] - P2[6] - 0.033	P2[4] - P2[6] + 0.002	P2[4] - P2[6] + 0.042	V
	RefPower = medium Opamp bias = high	V <sub>REFHI</sub>	Ref High	P2[4]+P2[6] (P2[4] = V <sub>DD</sub> /2, P2[6] = 0.5 V)	P2[4] + P2[6] - 0.094	P2[4] + P2[6] - 0.003	P2[4] + P2[6] + 0.075	V
		V <sub>AGND</sub>	AGND	P2[4]	P2[4]	P2[4]	P2[4]	-
		V <sub>REFLO</sub>	Ref Low	P2[4]-P2[6] (P2[4] = V <sub>DD</sub> /2, P2[6] = 0.5 V)	P2[4] - P2[6] - 0.035	P2[4] - P2[6]	P2[4] - P2[6] + 0.038	V
	RefPower = medium Opamp bias = low	V <sub>REFHI</sub>	Ref High	P2[4]+P2[6] (P2[4] = V <sub>DD</sub> /2, P2[6] = 0.5 V)	P2[4] + P2[6] - 0.095	P2[4] + P2[6] - 0.003	P2[4] + P2[6] + 0.080	V
		V <sub>AGND</sub>	AGND	P2[4]	P2[4]	P2[4]	P2[4]	-
		V <sub>REFLO</sub>	Ref Low	P2[4]-P2[6] (P2[4] = V <sub>DD</sub> /2, P2[6] = 0.5 V)	P2[4] - P2[6] - 0.038	P2[4] - P2[6]	P2[4] - P2[6] + 0.038	V
0b010	RefPower = high Opamp bias = high	V <sub>REFHI</sub>	Ref High	V <sub>DD</sub>	V <sub>DD</sub> - 0.119	V <sub>DD</sub> - 0.005	V <sub>DD</sub>	V
		V <sub>AGND</sub>	AGND	V <sub>DD</sub> /2	V <sub>DD</sub> /2 - 0.028	V <sub>DD</sub> /2	V <sub>DD</sub> /2 + 0.029	V
		V <sub>REFLO</sub>	Ref Low	V <sub>SS</sub>	V <sub>SS</sub>	V <sub>SS</sub> + 0.004	V <sub>SS</sub> + 0.022	V
	RefPower = high Opamp bias = low	V <sub>REFHI</sub>	Ref High	V <sub>DD</sub>	V <sub>DD</sub> - 0.131	V <sub>DD</sub> - 0.004	V <sub>DD</sub>	V
		V <sub>AGND</sub>	AGND	V <sub>DD</sub> /2	V <sub>DD</sub> /2 - 0.028	V <sub>DD</sub> /2	V <sub>DD</sub> /2 + 0.028	V
		V <sub>REFLO</sub>	Ref Low	V <sub>SS</sub>	V <sub>SS</sub>	V <sub>SS</sub> + 0.003	V <sub>SS</sub> + 0.021	V
	RefPower = medium Opamp bias = high	V <sub>REFHI</sub>	Ref High	V <sub>DD</sub>	V <sub>DD</sub> - 0.111	V <sub>DD</sub> - 0.003	V <sub>DD</sub>	V
		V <sub>AGND</sub>	AGND	V <sub>DD</sub> /2	V <sub>DD</sub> /2 - 0.029	V <sub>DD</sub> /2	V <sub>DD</sub> /2 + 0.028	V
		V <sub>REFLO</sub>	Ref Low	V <sub>SS</sub>	V <sub>SS</sub>	V <sub>SS</sub> + 0.002	V <sub>SS</sub> + 0.017	V
	RefPower = medium Opamp bias = low	V <sub>REFHI</sub>	Ref High	V <sub>DD</sub>	V <sub>DD</sub> - 0.128	V <sub>DD</sub> - 0.003	V <sub>DD</sub>	V
		V <sub>AGND</sub>	AGND	V <sub>DD</sub> /2	V <sub>DD</sub> /2 - 0.029	V <sub>DD</sub> /2	V <sub>DD</sub> /2 + 0.029	V
		V <sub>REFLO</sub>	Ref Low	V <sub>SS</sub>	V <sub>SS</sub>	V <sub>SS</sub> + 0.002	V <sub>SS</sub> + 0.019	V

Table 13. 3.3-V DC Analog Reference Specifications (continued)

Reference ARF_CR [5:3]	Reference Power Settings	Symbol	Reference	Description	Min	Typ	Max	Units
0b011	All power settings. Not allowed for 3.3 V.	–	–	–	–	–	–	–
0b100	All power settings. Not allowed for 3.3 V.	–	–	–	–	–	–	–
0b101	RefPower = high Opamp bias = high	V <sub>REFHI</sub>	Ref High	P2[4] + Bandgap (P2[4] = V <sub>DD</sub> /2)	P2[4] + 1.214	P2[4] + 1.291	P2[4] + 1.359	V
		V <sub>AGND</sub>	AGND	P2[4]	P2[4]	P2[4]	P2[4]	–
		V <sub>REFLO</sub>	Ref Low	P2[4] – Bandgap (P2[4] = V <sub>DD</sub> /2)	P2[4] – 1.335	P2[4] – 1.292	P2[4] – 1.200	V
	RefPower = high Opamp bias = low	V <sub>REFHI</sub>	Ref High	P2[4] + Bandgap (P2[4] = V <sub>DD</sub> /2)	P2[4] + 1.219	P2[4] + 1.293	P2[4] + 1.357	V
		V <sub>AGND</sub>	AGND	P2[4]	P2[4]	P2[4]	P2[4]	–
		V <sub>REFLO</sub>	Ref Low	P2[4] – Bandgap (P2[4] = V <sub>DD</sub> /2)	P2[4] – 1.335	P2[4] – 1.295	P2[4] – 1.243	V
	RefPower = medium Opamp bias = high	V <sub>REFHI</sub>	Ref High	P2[4] + Bandgap (P2[4] = V <sub>DD</sub> /2)	P2[4] + 1.222	P2[4] + 1.294	P2[4] + 1.356	V
		V <sub>AGND</sub>	AGND	P2[4]	P2[4]	P2[4]	P2[4]	–
		V <sub>REFLO</sub>	Ref Low	P2[4] – Bandgap (P2[4] = V <sub>DD</sub> /2)	P2[4] – 1.337	P2[4] – 1.296	P2[4] – 1.244	V
	RefPower = medium Opamp bias = low	V <sub>REFHI</sub>	Ref High	P2[4] + Bandgap (P2[4] = V <sub>DD</sub> /2)	P2[4] + 1.224	P2[4] + 1.295	P2[4] + 1.355	V
		V <sub>AGND</sub>	AGND	P2[4]	P2[4]	P2[4]	P2[4]	–
		V <sub>REFLO</sub>	Ref Low	P2[4] – Bandgap (P2[4] = V <sub>DD</sub> /2)	P2[4] – 1.339	P2[4] – 1.297	P2[4] – 1.244	V
0b110	RefPower = high Opamp bias = high	V <sub>REFHI</sub>	Ref High	2 × Bandgap	2.510	2.595	2.655	V
		V <sub>AGND</sub>	AGND	Bandgap	1.276	1.301	1.332	V
		V <sub>REFLO</sub>	Ref Low	V <sub>SS</sub>	V <sub>SS</sub>	V <sub>SS</sub> + 0.006	V <sub>SS</sub> + 0.031	V
	RefPower = high Opamp bias = low	V <sub>REFHI</sub>	Ref High	2 × Bandgap	2.513	2.594	2.656	V
		V <sub>AGND</sub>	AGND	Bandgap	1.275	1.301	1.331	V
		V <sub>REFLO</sub>	Ref Low	V <sub>SS</sub>	V <sub>SS</sub>	V <sub>SS</sub> + 0.004	V <sub>SS</sub> + 0.021	V
	RefPower = medium Opamp bias = high	V <sub>REFHI</sub>	Ref High	2 × Bandgap	2.516	2.595	2.657	V
		V <sub>AGND</sub>	AGND	Bandgap	1.275	1.301	1.331	V
		V <sub>REFLO</sub>	Ref Low	V <sub>SS</sub>	V <sub>SS</sub>	V <sub>SS</sub> + 0.003	V <sub>SS</sub> + 0.017	V
	RefPower = medium Opamp bias = low	V <sub>REFHI</sub>	Ref High	2 × Bandgap	2.520	2.595	2.658	V
		V <sub>AGND</sub>	AGND	Bandgap	1.275	1.300	1.331	V
		V <sub>REFLO</sub>	Ref Low	V <sub>SS</sub>	V <sub>SS</sub>	V <sub>SS</sub> + 0.002	V <sub>SS</sub> + 0.015	V
0b111	All power settings. Not allowed for 3.3 V.	–	–	–	–	–	–	



**DC Analog PSoC Block Specifications**

**Table 14** lists guaranteed maximum and minimum specifications for the voltage and temperature ranges: 4.75 V to 5.25 V and  $-40\text{ }^{\circ}\text{C} \leq T_A \leq 85\text{ }^{\circ}\text{C}$ , or 3.0 V to 3.6 V and  $-40\text{ }^{\circ}\text{C} \leq T_A \leq 85\text{ }^{\circ}\text{C}$ , respectively. Typical parameters apply to 5 V and 3.3 V at 25 °C and are for design guidance only.

**Table 14. DC Analog PSoC Block Specifications**

Symbol	Description	Min	Typ	Max	Units	Notes
R <sub>CT</sub>	Resistor unit value (continuous time)	–	12.2	–	kΩ	
C <sub>SC</sub>	Capacitor unit value (switched capacitor)	–	80	–	fF	

**DC POR and LVD Specifications**

**Table 15** lists guaranteed maximum and minimum specifications for the voltage and temperature ranges: 4.75 V to 5.25 V and  $-40\text{ }^{\circ}\text{C} \leq T_A \leq 85\text{ }^{\circ}\text{C}$ , or 3.0 V to 3.6 V and  $-40\text{ }^{\circ}\text{C} \leq T_A \leq 85\text{ }^{\circ}\text{C}$ , respectively. Typical parameters apply to 5 V or 3.3 V at 25 °C and are for design guidance only.

**Note** The bits PORLEV and VM in the table below refer to bits in the VLT\_CR register. See the *PSoC Technical Reference Manual* for more information on the VLT\_CR register.

**Table 15. DC POR and LVD Specifications**

Symbol	Description	Min	Typ	Max	Units	Notes
V <sub>PPOR0</sub> <sup>[7]</sup>	V <sub>DD</sub> Value for PPOR Trip (negative ramp) PORLEV[1:0] = 00b	–	2.82	–	V	V <sub>DD</sub> must be greater than or equal to 2.5 V during startup, reset from the XRES pin, or reset from watchdog.
V <sub>PPOR1</sub> <sup>[7]</sup>	PORLEV[1:0] = 01b	–	4.39	–	V	
V <sub>PPOR2</sub> <sup>[7]</sup>	PORLEV[1:0] = 10b	–	4.55	–	V	
V <sub>PH0</sub>	PPOR Hysteresis PORLEV[1:0] = 00b	–	92	–	mV	
V <sub>PH1</sub>	PORLEV[1:0] = 01b	–	0	–	mV	
V <sub>PH2</sub>	PORLEV[1:0] = 10b	–	0	–	mV	
V <sub>LVD0</sub>	V <sub>DD</sub> Value for LVD Trip VM[2:0] = 000b	2.86	2.92	3.02 <sup>[8]</sup>	V	
V <sub>LVD1</sub>	VM[2:0] = 001b	2.96	3.02	3.12	V	
V <sub>LVD2</sub>	VM[2:0] = 010b	3.07	3.13	3.24	V	
V <sub>LVD3</sub>	VM[2:0] = 011b	3.92	4.00	4.12	V	
V <sub>LVD4</sub>	VM[2:0] = 100b	4.39	4.48	4.62	V	
V <sub>LVD5</sub>	VM[2:0] = 101b	4.55	4.64	4.78 <sup>[9]</sup>	V	
V <sub>LVD6</sub>	VM[2:0] = 110b	4.63	4.73	4.87	V	
V <sub>LVD7</sub>	VM[2:0] = 111b	4.72	4.81	4.96	V	

**Notes**

7. **Errata:** When V<sub>DD</sub> of the device is pulled below ground just before power on, the first read from each 8K Flash page may be corrupted. This issue does not affect Flash page 0 because it is the selected page upon reset. More details in "Errata" on page 46.
8. Always greater than 50 mV above PPOR (PORLEV = 00) for falling supply.
9. Always greater than 50 mV above PPOR (PORLEV = 10) for falling supply.

### DC Programming Specifications

Table 16 lists guaranteed maximum and minimum specifications for the voltage and temperature ranges: 4.75 V to 5.25 V and  $-40\text{ }^{\circ}\text{C} \leq T_A \leq 85\text{ }^{\circ}\text{C}$ , or 3.0 V to 3.6 V and  $-40\text{ }^{\circ}\text{C} \leq T_A \leq 85\text{ }^{\circ}\text{C}$ , respectively. Typical parameters apply to 5 V and 3.3 V at 25 °C and are for design guidance only.

**Table 16. DC Programming Specifications**

Symbol	Description	Min	Typ	Max	Units	Notes
V <sub>DDP</sub>	V <sub>DD</sub> for programming and erase	4.5	5.0	5.5	V	This specification applies to the functional requirements of external programmer tools
V <sub>DDL</sub>	Low V <sub>DD</sub> for verify	3.0	3.1	3.2	V	This specification applies to the functional requirements of external programmer tools
V <sub>DDH</sub>	High V <sub>DD</sub> for verify	5.1	5.2	5.3	V	This specification applies to the functional requirements of external programmer tools
V <sub>DDIWRITE</sub>	Supply voltage for flash write operation	3.0	–	5.25	V	This specification applies to this device when it is executing internal flash writes
I <sub>DDP</sub>	Supply current during programming or verify	–	15	30	mA	
V <sub>ILP</sub>	Input low voltage during programming or verify	–	–	0.8	V	
V <sub>IHP</sub>	Input high voltage during programming or verify	2.1	–	–	V	
I <sub>ILP</sub>	Input current when applying V <sub>ILP</sub> to P1[0] or P1[1] during programming or verify	–	–	0.2	mA	Driving internal pull-down resistor.
I <sub>IHP</sub>	Input current when applying V <sub>IHP</sub> to P1[0] or P1[1] during programming or verify	–	–	1.5	mA	Driving internal pull-down resistor.
V <sub>OLV</sub>	Output low voltage during programming or verify	–	–	0.75	V	
V <sub>OHV</sub>	Output high voltage during programming or verify	V <sub>DD</sub> – 1.0	–	V <sub>DD</sub>	V	
Flash <sub>ENPB</sub>	Flash endurance (per block) <sup>[10, 11]</sup>	1,000	–	–	–	Erase/write cycles per block.
Flash <sub>ENT</sub>	Flash endurance (total) <sup>[11, 12]</sup>	256,000	–	–	–	Erase/write cycles.
Flash <sub>DR</sub>	Flash data retention <sup>[11]</sup>	10	–	–	Years	

#### Notes

10. The erase/write cycle limit per block (Flash<sub>ENPB</sub>) is only guaranteed if the device operates within one voltage range. Voltage ranges are 3.0 V to 3.6 V and 4.75 V to 5.25 V.
11. For the full temperature range, the user must employ a temperature sensor user module (FlashTemp) or other temperature sensor, and feed the result to the temperature argument before writing. Refer to the Flash APIs Application Note AN2015 for more information.
12. The maximum total number of allowed erase/write cycles is the minimum Flash<sub>ENPB</sub> value multiplied by the number of flash blocks in the device.

## AC Electrical Characteristics

### AC Chip-Level Specifications

Table 17 lists guaranteed maximum and minimum specifications for the voltage and temperature ranges: 4.75 V to 5.25 V and  $-40\text{ }^{\circ}\text{C} \leq T_A \leq 85\text{ }^{\circ}\text{C}$ , or 3.0 V to 3.6 V and  $-40\text{ }^{\circ}\text{C} \leq T_A \leq 85\text{ }^{\circ}\text{C}$ , respectively. Typical parameters apply to 5 V and 3.3 V at 25 °C and are for design guidance only.

**Table 17. AC Chip-Level Specifications**

Symbol	Description	Min	Typ	Max	Units	Notes
F <sub>IMO245V</sub>	IMO frequency for 24 MHz (5 V nominal)	23.04 <sup>[13]</sup>	24	24.96 <sup>[13]</sup>	MHz	Trimmed for 5 V operation using factory trim values.
F <sub>IMO243V</sub>	IMO frequency for 24 MHz (3.3 V nominal)	22.08 <sup>[13]</sup>	24	25.92 <sup>[13]</sup>	MHz	Trimmed for 3.3 V operation using factory trim values.
F <sub>CPU1</sub>	CPU frequency (5 V nominal)	0.090 <sup>[13]</sup>	24	24.96 <sup>[13]</sup>	MHz	SLIMO mode = 0.
F <sub>CPU2</sub>	CPU frequency (3.3 V nominal)	0.086 <sup>[13]</sup>	12	12.96 <sup>[13]</sup>	MHz	SLIMO mode = 0.
F <sub>BLK5</sub>	Digital PSoC block frequency (5 V nominal)	0	48	49.92 <sup>[13,14]</sup>	MHz	Refer to the <a href="#">AC Digital Block Specifications</a> .
F <sub>BLK3</sub>	Digital PSoC block frequency (3.3 V nominal)	0	24	25.92 <sup>[13,14]</sup>	MHz	Refer to the <a href="#">AC Digital Block Specifications</a> .
F <sub>32K1</sub>	ILO frequency	15	32	64	kHz	This specification applies when the ILO has been trimmed.
F <sub>32KU</sub>	ILO untrimmed frequency	5	–	100	kHz	After a reset and before the M8C processor starts to execute, the ILO is not trimmed.
t <sub>XRST</sub>	External reset pulse width	10	–	–	μs	
DC <sub>24M</sub>	24 MHz duty cycle	40	50	60	%	
DC <sub>ILO</sub>	ILO duty cycle	20	50	80	%	
Step <sub>24M</sub>	24 MHz trim step size	–	50	–	kHz	
F <sub>out48M</sub>	48 MHz output frequency	46.08 <sup>[13]</sup>	48	49.92 <sup>[13]</sup>	MHz	4.75 V ≤ V <sub>DD</sub> ≤ 5.25 V
F <sub>MAX</sub>	Maximum frequency of signal on row input or row output.	–	–	12.96 <sup>[13]</sup>	MHz	
SR <sub>POWERUP</sub>	Power supply slew rate	–	–	250	V/ms	V <sub>DD</sub> slew rate during power-up.
t <sub>POWERUP</sub>	Time between end of POR state and CPU code execution	–	16	100	ms	Power-up from 0 V.
t <sub>JIT_IMO</sub> <sup>[15]</sup>	24 MHz IMO cycle-to-cycle jitter (RMS)	–	200	1200	ps	
	24 MHz IMO long term N cycle-to-cycle jitter (RMS)	–	900	6000	ps	N = 32
	24 MHz IMO period jitter (RMS)	–	200	900	ps	

#### Notes

13. Accuracy derived from IMO with appropriate trim for V<sub>DD</sub> range.

14. See the individual user module datasheets for information on maximum frequencies for user modules.

15. Refer to Cypress Jitter Specifications application note, [Understanding Datasheet Jitter Specifications for Cypress Timing Products – AN5054](#) for more information.

### AC GPIO Specifications

Table 18 lists guaranteed maximum and minimum specifications for the voltage and temperature ranges: 4.75 V to 5.25 V and  $-40\text{ }^{\circ}\text{C} \leq T_A \leq 85\text{ }^{\circ}\text{C}$ , or 3.0 V to 3.6 V and  $-40\text{ }^{\circ}\text{C} \leq T_A \leq 85\text{ }^{\circ}\text{C}$ , respectively. Typical parameters apply to 5 V and 3.3 V at 25  $^{\circ}\text{C}$  and are for design guidance only.

**Table 18. AC GPIO Specifications**

Symbol	Description	Min	Typ	Max	Units	Notes
$F_{\text{GPIO}}$	GPIO operating frequency	0	–	12.96 <sup>[16]</sup>	MHz	Normal Strong Mode
$t_{\text{RISEF}}$	Rise time, normal strong mode, Clload = 50 pF	3	–	18	ns	$V_{\text{DD}} = 4.5$ to 5.25 V, 10% to 90%
$t_{\text{FALLF}}$	Fall time, normal strong mode, Clload = 50 pF	2	–	18	ns	$V_{\text{DD}} = 4.5$ to 5.25 V, 10% to 90%
$t_{\text{RISES}}$	Rise time, slow strong mode, Clload = 50 pF	10	27	–	ns	$V_{\text{DD}} = 3$ to 5.25 V, 10% to 90%
$t_{\text{FALLS}}$	Fall time, slow strong mode, Clload = 50 pF	10	22	–	ns	$V_{\text{DD}} = 3$ to 5.25 V, 10% to 90%

**Figure 5. GPIO Timing Diagram**

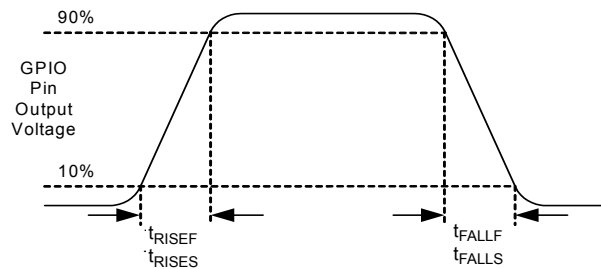

**Note**

16. Specification derived from the accuracy of the Internal Main Oscillator (IMO) with appropriate trim for  $V_{\text{DD}}$  range.

**AC Operational Amplifier Specifications**

Table 19 and Table 20 list the guaranteed maximum and minimum specifications for the voltage and temperature ranges: 4.75 V to 5.25 V and  $-40\text{ }^{\circ}\text{C} \leq T_A \leq 85\text{ }^{\circ}\text{C}$ , or 3.0 V to 3.6 V and  $-40\text{ }^{\circ}\text{C} \leq T_A \leq 85\text{ }^{\circ}\text{C}$ , respectively. Typical parameters apply to 5 V and 3.3 V at 25 °C and are for design guidance only.

Settling times, slew rates, and gain bandwidth are based on the Analog Continuous Time PSoC block.

Power = high and Opamp bias = high is not supported at 3.3 V.

**Table 19. 5-V AC Operational Amplifier Specifications**

Symbol	Description	Min	Typ	Max	Units
$t_{ROA}$	Rising settling time from 80% of $\Delta V$ to 0.1% of $\Delta V$ (10 pF load, unity gain)				
	Power = low, Opamp bias = low	–	–	3.9	$\mu\text{s}$
	Power = medium, Opamp bias = high	–	–	0.72	$\mu\text{s}$
	Power = high, Opamp bias = high	–	–	0.62	$\mu\text{s}$
$t_{SOA}$	Falling settling time from 20% of $\Delta V$ to 0.1% of $\Delta V$ (10 pF load, unity gain)				
	Power = low, Opamp bias = low	–	–	5.9	$\mu\text{s}$
	Power = medium, Opamp bias = high	–	–	0.92	$\mu\text{s}$
	Power = high, Opamp bias = high	–	–	0.72	$\mu\text{s}$
$SR_{ROA}$	Rising slew rate (20% to 80%) (10 pF load, unity gain)				
	Power = low, Opamp bias = low	0.15	–	–	V/ $\mu\text{s}$
	Power = medium, Opamp bias = high	1.7	–	–	V/ $\mu\text{s}$
	Power = high, Opamp bias = high	6.5	–	–	V/ $\mu\text{s}$
$SR_{FOA}$	Falling slew rate (20% to 80%) (10 pF load, unity gain)				
	Power = low, Opamp bias = low	0.01	–	–	V/ $\mu\text{s}$
	Power = medium, Opamp bias = high	0.5	–	–	V/ $\mu\text{s}$
	Power = high, Opamp bias = high	4.0	–	–	V/ $\mu\text{s}$
$BW_{OA}$	Gain bandwidth product				
	Power = low, Opamp bias = low	0.75	–	–	MHz
	Power = medium, Opamp bias = high	3.1	–	–	MHz
	Power = high, Opamp bias = high	5.4	–	–	MHz
$E_{NOA}$	Noise at 1 kHz (Power = medium, Opamp bias = high)	–	100	–	nV/rt-Hz

**Table 20. 3.3-V AC Operational Amplifier Specifications**

Symbol	Description	Min	Typ	Max	Units
$t_{ROA}$	Rising settling time from 80% of $\Delta V$ to 0.1% of $\Delta V$ (10 pF load, unity gain)				
	Power = low, Opamp bias = low	–	–	3.92	$\mu\text{s}$
	Power = medium, Opamp bias = high	–	–	0.72	$\mu\text{s}$
$t_{SOA}$	Falling settling time from 20% of $\Delta V$ to 0.1% of $\Delta V$ (10 pF load, unity gain)				
	Power = low, Opamp bias = low	–	–	5.41	$\mu\text{s}$
	Power = medium, Opamp bias = high	–	–	0.72	$\mu\text{s}$
$SR_{ROA}$	Rising slew rate (20% to 80%) (10 pF load, unity gain)				
	Power = low, Opamp bias = low	0.31	–	–	V/ $\mu\text{s}$
	Power = medium, Opamp bias = high	2.7	–	–	V/ $\mu\text{s}$
$SR_{FOA}$	Falling slew rate (20% to 80%) (10 pF load, Unity Gain)				
	Power = low, Opamp bias = low	0.24	–	–	V/ $\mu\text{s}$
	Power = medium, Opamp bias = high	1.8	–	–	V/ $\mu\text{s}$
$BW_{OA}$	Gain bandwidth product				
	Power = low, Opamp bias = low	0.67	–	–	MHz
	Power = medium, Opamp bias = high	2.8	–	–	MHz
$E_{NOA}$	Noise at 1 kHz (Power = medium, Opamp bias = high)	–	100	–	nV/rt-Hz

When bypassed by a capacitor on P2[4], the noise of the analog ground signal distributed to each block is reduced by a factor of up to 5 (14 dB). This is at frequencies above the corner frequency defined by the on-chip 8.1 kΩ resistance and the external capacitor.

**Figure 6. Typical AGND Noise with P2[4] Bypass**

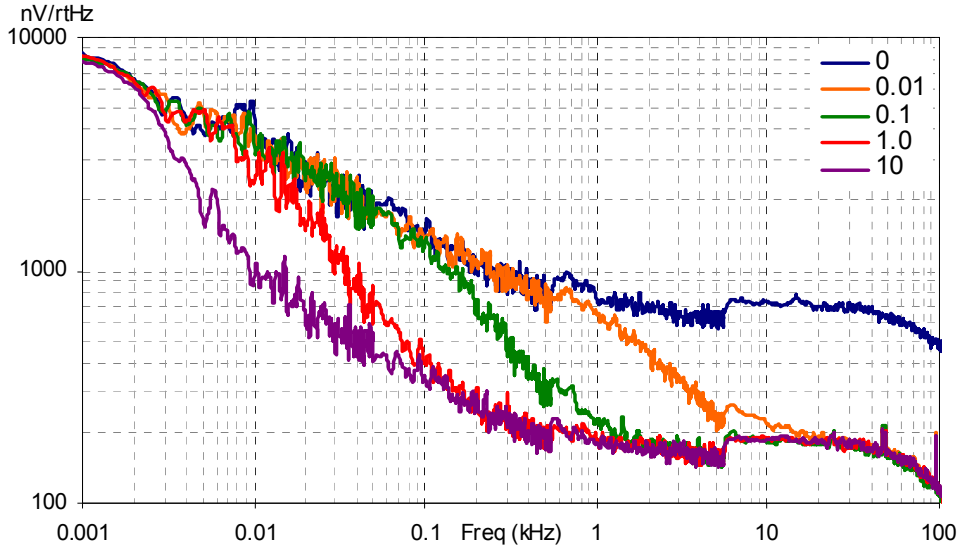

At low frequencies, the opamp noise is proportional to 1/f, power independent, and determined by device geometry. At high frequencies, increased power level reduces the noise spectrum level.

**Figure 7. Typical Opamp Noise**

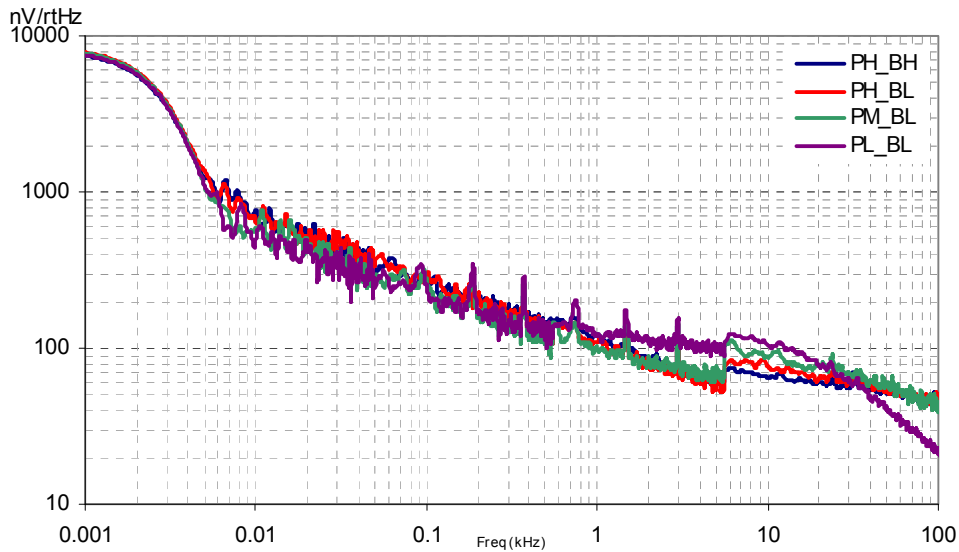

AC Low Power Comparator Specifications

Table 21 lists guaranteed maximum and minimum specifications for the voltage and temperature ranges: 4.75 V to 5.25 V and  $-40\text{ }^{\circ}\text{C} \leq T_A \leq 85\text{ }^{\circ}\text{C}$ , or 3.0 V to 3.6 V and  $-40\text{ }^{\circ}\text{C} \leq T_A \leq 85\text{ }^{\circ}\text{C}$ , respectively. Typical parameters apply to 5 V at 25 °C and are for design guidance only.

Table 21. AC Low Power Comparator Specifications

Symbol	Description	Min	Typ	Max	Units	Notes
$t_{RLPC}$	LPC response time	–	–	50	$\mu\text{s}$	$\geq 50\text{ mV}$ overdrive comparator reference set within $V_{REFLPC}$ .

AC Digital Block Specifications

Table 22 lists guaranteed maximum and minimum specifications for the voltage and temperature ranges: 4.75 V to 5.25 V and  $-40\text{ }^{\circ}\text{C} \leq T_A \leq 85\text{ }^{\circ}\text{C}$ , or 3.0 V to 3.6 V and  $-40\text{ }^{\circ}\text{C} \leq T_A \leq 85\text{ }^{\circ}\text{C}$ , respectively. Typical parameters apply to 5 V and 3.3 V at 25 °C and are for design guidance only.

Table 22. AC Digital Block Specifications

Function	Description	Min	Typ	Max	Units	Notes
All functions	Block input clock frequency					
	$V_{DD} \geq 4.75\text{ V}$	–	–	49.92 <sup>[17]</sup>	MHz	
	$V_{DD} < 4.75\text{ V}$	–	–	25.92 <sup>[17]</sup>	MHz	
Timer	Input clock frequency					
	No capture, $V_{DD} \geq 4.75\text{ V}$	–	–	49.92 <sup>[17]</sup>	MHz	
	No capture, $V_{DD} < 4.75\text{ V}$	–	–	25.92 <sup>[17]</sup>	MHz	
	With capture	–	–	25.92 <sup>[17]</sup>	MHz	
	Capture pulse width	50 <sup>[18]</sup>	–	–	ns	
Counter	Input clock frequency					
	No enable input, $V_{DD} \geq 4.75\text{ V}$	–	–	49.92 <sup>[17]</sup>	MHz	
	No enable input, $V_{DD} < 4.75\text{ V}$	–	–	25.92 <sup>[17]</sup>	MHz	
	With enable input	–	–	25.92 <sup>[17]</sup>	MHz	
	Enable input pulse width	50 <sup>[18]</sup>	–	–	ns	
Dead Band	Kill pulse width					
	Asynchronous restart mode	20	–	–	ns	
	Synchronous restart mode	50 <sup>[18]</sup>	–	–	ns	
	Disable mode	50 <sup>[18]</sup>	–	–	ns	
	Input clock frequency					
	$V_{DD} \geq 4.75\text{ V}$	–	–	49.92 <sup>[17]</sup>	MHz	
$V_{DD} < 4.75\text{ V}$	–	–	25.92 <sup>[17]</sup>	MHz		
CRCPRS (PRS Mode)	Input clock frequency					
	$V_{DD} \geq 4.75\text{ V}$	–	–	49.92 <sup>[17]</sup>	MHz	
	$V_{DD} < 4.75\text{ V}$	–	–	25.92 <sup>[17]</sup>	MHz	
CRCPRS (CRC Mode)	Input clock frequency	–	–	25.92 <sup>[17]</sup>	MHz	
SPIM	Input clock frequency	–	–	8.64 <sup>[17]</sup>	MHz	The SPI serial clock (SCLK) frequency is equal to the input clock frequency divided by 2.
SPIS	Input clock (SCLK) frequency	–	–	4.32 <sup>[17]</sup>	MHz	The input clock is the SPI SCLK in SPIS mode.
	Width of SS_Negated between transmissions	50 <sup>[18]</sup>	–	–	ns	
Transmitter	Input Clock Frequency					The baud rate is equal to the input clock frequency divided by 8.
	$V_{DD} \geq 4.75\text{ V}$ , 2 stop bits	–	–	49.92 <sup>[17]</sup>	MHz	
	$V_{DD} \geq 4.75\text{ V}$ , 1 stop bit	–	–	25.92 <sup>[17]</sup>	MHz	
	$V_{DD} < 4.75\text{ V}$	–	–	25.92 <sup>[17]</sup>	MHz	

Notes

17. Accuracy derived from IMO with appropriate trim for  $V_{DD}$  range.

18. 50 ns minimum input pulse width is based on the input synchronizers running at 24 MHz (42 ns nominal period).

**Table 22. AC Digital Block Specifications (continued)**

Function	Description	Min	Typ	Max	Units	Notes
Receiver	Input clock frequency					The baud rate is equal to the input clock frequency divided by 8.
	$V_{DD} \geq 4.75$ V, 2 stop bits	–	–	49.92 <sup>[17]</sup>	MHz	
	$V_{DD} \geq 4.75$ V, 1 stop bit	–	–	25.92 <sup>[17]</sup>	MHz	
	$V_{DD} < 4.75$ V	–	–	25.92 <sup>[17]</sup>	MHz	

**AC External Clock Specifications**

Table 23 list guaranteed maximum and minimum specifications for the voltage and temperature ranges: 4.75 V to 5.25 V and  $-40\text{ }^{\circ}\text{C} \leq T_A \leq 85\text{ }^{\circ}\text{C}$ , or 3.0 V to 3.6 V and  $-40\text{ }^{\circ}\text{C} \leq T_A \leq 85\text{ }^{\circ}\text{C}$ , respectively. Typical parameters apply to 5 V and 3.3 V at 25 °C and are for design guidance only.

**Table 23. AC External Clock Specifications**

Symbol	Description	Min	Typ	Max	Units	Notes
$F_{OSCEXT}$	Frequency	0	–	24.24	MHz	
–	High period	20.5	–	–	ns	
–	Low period	20.5	–	–	ns	
–	Power-up IMO to switch	150	–	–	$\mu\text{s}$	

**AC Analog Output Buffer Specifications**

Table 24 and Table 25 on page 33 list the guaranteed maximum and minimum specifications for the voltage and temperature ranges: 4.75 V to 5.25 V and  $-40\text{ }^{\circ}\text{C} \leq T_A \leq 85\text{ }^{\circ}\text{C}$ , or 3.0 V to 3.6 V and  $-40\text{ }^{\circ}\text{C} \leq T_A \leq 85\text{ }^{\circ}\text{C}$ , respectively. Typical parameters apply to 5 V and 3.3 V at 25 °C and are for design guidance only.

**Table 24. 5-V AC Analog Output Buffer Specifications**

Symbol	Description	Min	Typ	Max	Units	Notes
$t_{ROB}$	Rising settling time to 0.1%, 1 V step, 100pF load Power = low Power = high	–	–	2.5	$\mu\text{s}$	
		–	–	2.5	$\mu\text{s}$	
$t_{SOB}$	Falling settling time to 0.1%, 1 V step, 100pF load Power = low Power = high	–	–	2.2	$\mu\text{s}$	
		–	–	2.2	$\mu\text{s}$	
$SR_{ROB}$	Rising slew rate (20% to 80%), 1 V step, 100 pF load Power = low Power = high	0.65	–	–	V/ $\mu\text{s}$	
		0.65	–	–	V/ $\mu\text{s}$	
$SR_{FOB}$	Falling slew rate (80% to 20%), 1 V step, 100 pF load Power = low Power = high	0.65	–	–	V/ $\mu\text{s}$	
		0.65	–	–	V/ $\mu\text{s}$	
$BW_{OBSS}$	Small signal bandwidth, 20 mV <sub>pp</sub> , 3 dB BW, 100 pF load Power = low Power = high	0.8	–	–	MHz	
		0.8	–	–	MHz	
$BW_{OBLs}$	Large signal bandwidth, 1 V <sub>pp</sub> , 3 dB BW, 100 pF load Power = low Power = high	300	–	–	kHz	
		300	–	–	kHz	



**Table 25. 3.3-V AC Analog Output Buffer Specifications**

Symbol	Description	Min	Typ	Max	Units	Notes
$t_{ROB}$	Rising settling time to 0.1%, 1 V step, 100 pF load Power = low Power = high	–	–	3.8	$\mu\text{s}$	
		–	–	3.8	$\mu\text{s}$	
$t_{SOB}$	Falling settling time to 0.1%, 1 V step, 100 pF load Power = low Power = high	–	–	2.6	$\mu\text{s}$	
		–	–	2.6	$\mu\text{s}$	
$SR_{ROB}$	Rising slew rate (20% to 80%), 1 V step, 100 pF load Power = low Power = high	0.5	–	–	$\text{V}/\mu\text{s}$	
		0.5	–	–	$\text{V}/\mu\text{s}$	
$SR_{FOB}$	Falling slew rate (80% to 20%), 1 V step, 100 pF load Power = low Power = high	0.5	–	–	$\text{V}/\mu\text{s}$	
		0.5	–	–	$\text{V}/\mu\text{s}$	
$BW_{OBSS}$	Small signal bandwidth, 20 mV <sub>pp</sub> , 3 dB BW, 100 pF load Power = low Power = high	0.7	–	–	MHz	
		0.7	–	–	MHz	
$BW_{OBSL}$	Large signal bandwidth, 1 V <sub>pp</sub> , 3 dB BW, 100 pF load Power = low Power = high	200	–	–	kHz	
		200	–	–	kHz	

**AC Programming Specifications**

Table 26 lists guaranteed maximum and minimum specifications for the voltage and temperature ranges: 4.75 V to 5.25 V and  $-40\text{ }^{\circ}\text{C} \leq T_A \leq 85\text{ }^{\circ}\text{C}$ , or 3.0 V to 3.6 V and  $-40\text{ }^{\circ}\text{C} \leq T_A \leq 85\text{ }^{\circ}\text{C}$ , respectively. Typical parameters apply to 5 V and 3.3 V at 25  $^{\circ}\text{C}$  and are for design guidance only.

**Table 26. AC Programming Specifications**

Symbol	Description	Min	Typ	Max	Units	Notes
$t_{RSCLK}$	Rise time of SCLK	1	–	20	ns	
$t_{FSCLK}$	Fall time of SCLK	1	–	20	ns	
$t_{SSCLK}$	Data setup time to falling edge of SCLK	40	–	–	ns	
$t_{HSCLK}$	Data hold time from falling edge of SCLK	40	–	–	ns	
$F_{SCLK}$	Frequency of SCLK	0	–	8	MHz	
$t_{ERASEB}$	Flash erase time (block)	–	10	40 <sup>[19]</sup>	ms	
$t_{WRITE}$	Flash block write time	–	40	160 <sup>[19]</sup>	ms	
$t_{DSCLK}$	Data out delay from falling edge of SCLK	–	–	45	ns	$V_{DD} > 3.6\text{ V}$
$t_{DSCLK3}$	Data out delay from falling edge of SCLK	–	–	50	ns	$3.0\text{ V} \leq V_{DD} \leq 3.6\text{ V}$
$t_{PRGH}$	Total flash block program time ( $t_{ERASEB} + t_{WRITE}$ ), hot	–	–	100 <sup>[19]</sup>	ms	$T_J \geq 0\text{ }^{\circ}\text{C}$
$t_{PRGC}$	Total flash block program time ( $t_{ERASEB} + t_{WRITE}$ ), cold	–	–	200 <sup>[19]</sup>	ms	$T_J < 0\text{ }^{\circ}\text{C}$

**Note**

19. For the full temperature range, the user must employ a temperature sensor user module (FlashTemp) or other temperature sensor, and feed the result to the temperature argument before writing. Refer to the Flash APIs Application Note AN2015 for more information.

AC I<sup>2</sup>C Specifications

Table 27 lists guaranteed maximum and minimum specifications for the voltage and temperature ranges: 4.75 V to 5.25 V and -40 °C ≤ T<sub>A</sub> ≤ 85 °C, or 3.0 V to 3.6 V and -40 °C ≤ T<sub>A</sub> ≤ 85 °C, respectively. Typical parameters apply to 5 V and 3.3 V at 25 °C and are for design guidance only.

Table 27. AC Characteristics of the I<sup>2</sup>C SDA and SCL Pins for V<sub>DD</sub>

Symbol	Description	Standard Mode		Fast Mode		Units	Notes
		Min	Max	Min	Max		
F <sub>SCL I2C</sub>	SCL clock frequency	0	100 <sup>[20]</sup>	0	400 <sup>[20]</sup>	kHz	
t <sub>HDSTAI2C</sub>	Hold time (repeated) START condition. After this period, the first clock pulse is generated.	4.0	–	0.6	–	μs	
t <sub>LOW I2C</sub>	LOW period of the SCL clock	4.7	–	1.3	–	μs	
t <sub>HIGH I2C</sub>	HIGH period of the SCL clock	4.0	–	0.6	–	μs	
t <sub>SUSTA I2C</sub>	Setup time for a repeated START condition	4.7	–	0.6	–	μs	
t <sub>HDDAT I2C</sub>	Data hold time	0	–	0	–	μs	
t <sub>SUDAT I2C</sub>	Data setup time	250	–	100 <sup>[21]</sup>	–	ns	
t <sub>SUSTO I2C</sub>	Setup time for STOP condition	4.0	–	0.6	–	μs	
t <sub>BUFI2C</sub>	Bus free time between a stop and start condition	4.7	–	1.3	–	μs	
t <sub>SPI2C</sub>	Pulse width of spikes are suppressed by the input filter.	–	–	0	50	ns	

Figure 8. Definition for Timing for Fast/Standard Mode on the I<sup>2</sup>C Bus

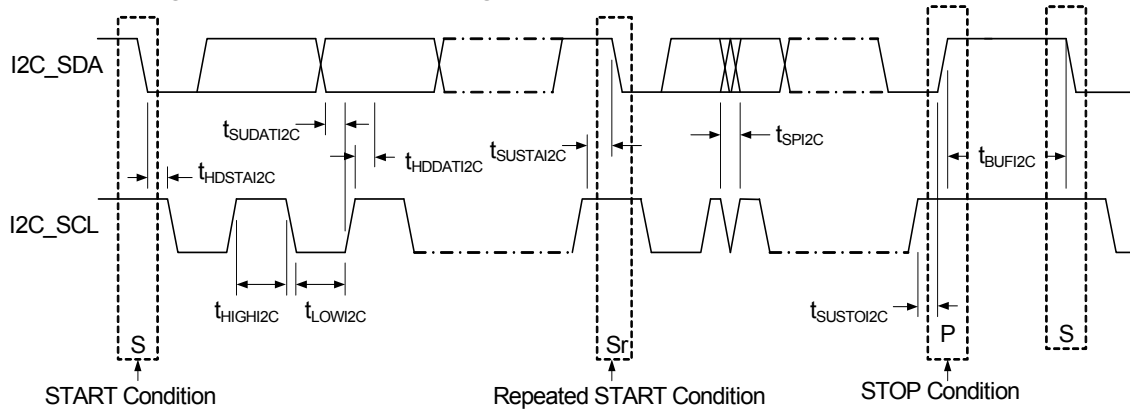

Notes

- 20. F<sub>SCL I2C</sub> is derived from SysClk of the PSoC. This specification assumes that SysClk is operating at 24 MHz, nominal. If SysClk is at a lower frequency, then the F<sub>SCL I2C</sub> specification adjusts accordingly.
- 21. A Fast-Mode I2C-bus device can be used in a Standard-Mode I2C-bus system, but the requirement t<sub>SUDAT I2C</sub> ≥ 250 ns must then be met. This is automatically the case if the device does not stretch the LOW period of the SCL signal. If such device does stretch the LOW period of the SCL signal, it must output the next data bit to the SDA line t<sub>rmax</sub> + t<sub>SUDAT I2C</sub> = 1000 + 250 = 1250 ns (according to the Standard-Mode I2C-bus specification) before the SCL line is released.

## Packaging Information

This section illustrates the package specification for the CY8C24x94 PSoC devices, along with the thermal impedance for the package and solder reflow peak temperatures.

**Note** Emulation tools may require a larger area on the target PCB than the chip's footprint. For a detailed description of the emulation tools' dimensions, refer to the emulator pod drawings at <http://www.cypress.com>.

**Figure 9. 56-Pin (8 × 8 mm) QFN (Punched)**

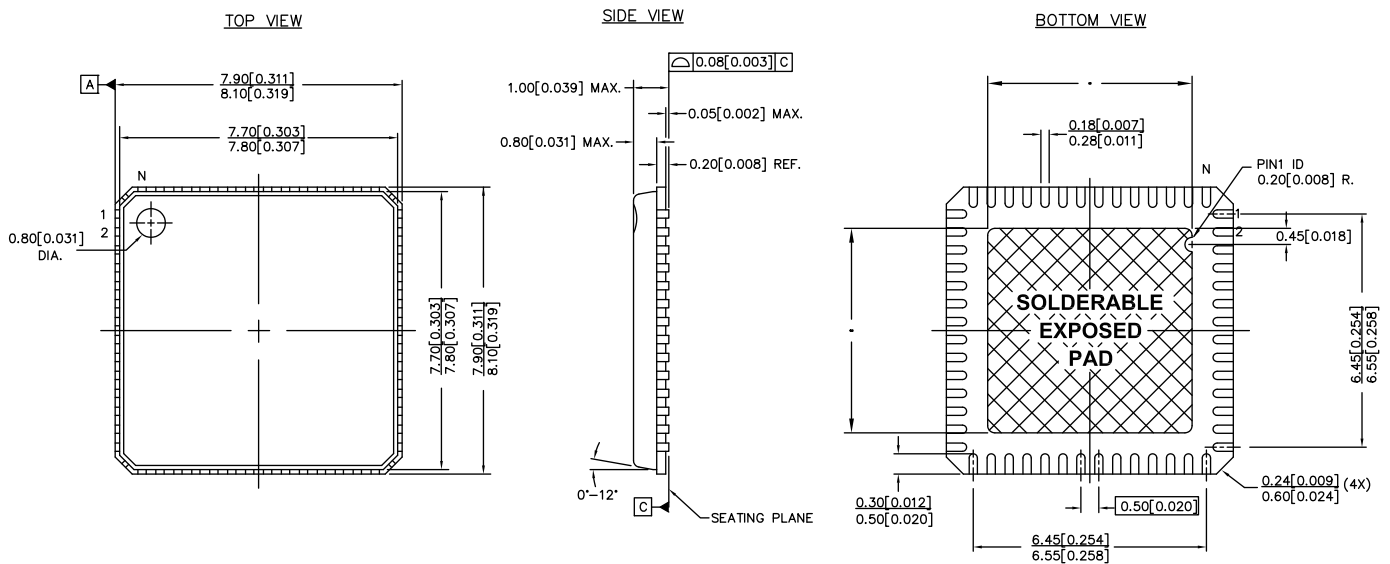

**NOTES:**

1.  HATCH AREA IS SOLDERABLE EXPOSED METAL.
2. REFERENCE JEDEC#: MO-220
3. PACKAGE WEIGHT: 0.162g
4. ALL DIMENSIONS ARE IN MM [MIN/MAX]
5. PACKAGE CODE

PART #	DESCRIPTION
LF56A	STANDARD
LY56A	PB-FREE

001-12921 \*C

### Important Note

- For information on the preferred dimensions for mounting QFN packages, see the following application note, *Application Notes for Surface Mount Assembly of Amkor's MicroLeadFrame (MLF) Packages* available at <http://www.amkor.com>.
- Pinned vias for thermal conduction are not required for the low power PSoC device.

### Thermal Impedances

**Table 28. Thermal Impedance per Package**

Package	Typical $\theta_{JA}$ [22]	Typical $\theta_{JC}$
56-pin QFN [23]	19 °C/W	1.7 °C/W

### Solder Reflow Specifications

Table 29 shows the solder reflow temperature limits that must not be exceeded.

**Table 29. Solder Reflow Specifications**

Package	Maximum Peak Temperature ( $T_C$ )	Maximum Time above $T_C - 5$ °C
56-pin QFN	260 °C	30 seconds

**Notes**

22.  $T_J = T_A + Power \times \theta_{JA}$ .

23. To achieve the thermal impedance specified for the QFN package, refer to the application notes for Surface Mount Assembly of Amkor's MicroLeadFrame (MLF) Packages available at <http://www.amkor.com>.

Tape and Reel Information

Figure 10. 56-Pin (8 × 8 mm) QFN (Punched) Carrier Tape Drawing

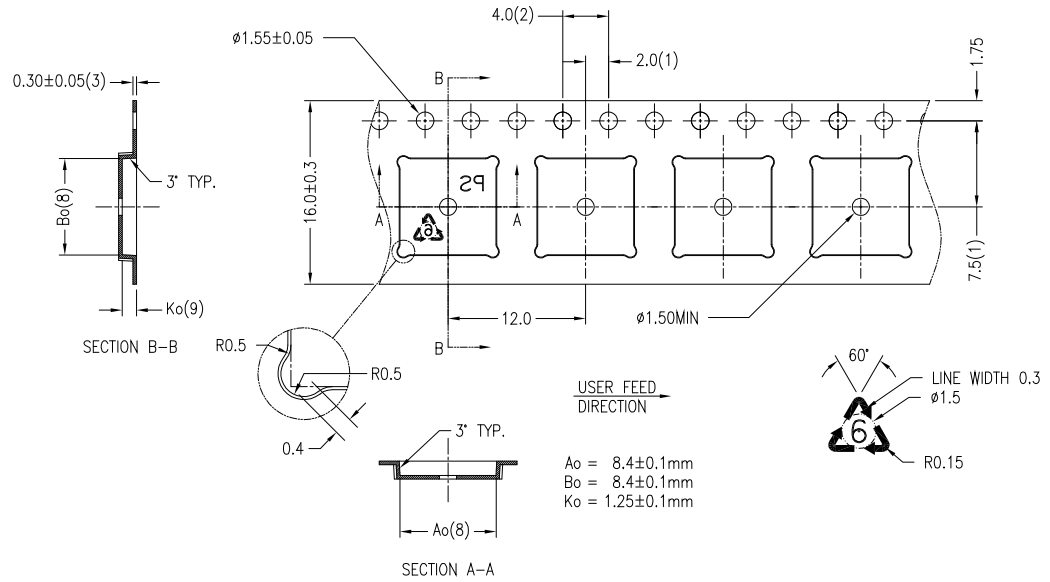

- NOTES:
- (1). MEASURED FROM THE CENTERLINE OF SPROCKET HOLE TO CENTERLINE OF THE POCKET HOLE AND FROM THE CENTERLINE OF SPROCKET HOLE TO CENTERLINE OF THE POCKET.
  - (2). CUMULATIVE TOLERANCE OF 10 SPROCKET HOLES IS  $\pm 0.20$
  - (3). THIS THICKNESS IS APPLICABLE AS MEASURE AT THE EDGE OF THE TAPE.
  4. MATERIAL:BLACK POLYSTYRENE
  5. DIMENSIONS ARE IN MILLIMETERS.
  6. ALLOWABLE CAMBER TO BE 1MM PER 100MM IN LENGTH, NON-CUMULATIVE OVER 250MM.
  7. UNLESS OTHERWISE SPECIFIED TOLERANCE  $\pm 0.10$ .
  - (8). MEASUREMENT POINT TO BE 0.3 FROM BOTTOM POCKET.
  - (9).  $K_o$  MEASUREMENT POINT SHOULD NOT BE REFERRED ON POCKET RIDGE.
  10. SURFACE RESISTIVITY FROM  $10^5$  TO  $10^{11}$  OHMS/SQ

51-51165 \*C

Table 30. Tape and Reel Specifications

Package	Cover Tape Width (mm)	Hub Size (inches)	Minimum Leading Empty Pockets	Minimum Trailing Empty Pockets	Standard Full Reel Quantity
56-Pin QFN	13.1	7	42	25	2000

## Development Tool Selection

### Software

#### *PSoC Designer*

At the core of the PSoC development software suite is PSoC Designer, used to generate PSoC firmware applications. PSoC Designer is available free of charge at <http://www.cypress.com> and includes a free C compiler.

#### *PSoC Programmer*

Flexible enough to be used on the bench in development, yet suitable for factory programming, PSoC Programmer works either as a standalone programming application or it can operate directly from PSoC Designer or PSoC Express. PSoC Programmer software is compatible with both PSoC ICE-Cube In-Circuit Emulator and PSoC MiniProg. PSoC programmer is available free of charge at <http://www.cypress.com>.

### Development Kits

All development kits can be purchased from the [Cypress Online Store](#). The online store also has the most up to date information on kit contents, descriptions, and availability.

#### *CY3215-DK Basic Development Kit*

The **CY3215-DK** is for prototyping and development with PSoC Designer. This kit supports in-circuit emulation and the software interface allows users to run, halt, and single step the processor and view the contents of specific memory locations. Advanced emulation features are also supported through PSoC Designer. The kit includes:

- ICE-Cube unit
- 28-pin PDIP emulation pod for CY8C29466-24PXI
- 28-pin CY8C29466-24PXI PDIP PSoC device samples (two)
- PSoC Designer software CD
- ISSP cable
- MiniEval socket programming and evaluation board
- Backward compatibility cable (for connecting to legacy pods)

- Universal 110/220 power supply (12 V)
- European plug adapter
- USB 2.0 cable
- Getting Started Guide
- Development kit registration form

### Evaluation Tools

All evaluation tools can be purchased from the [Cypress Online Store](#). The online store also has the most up to date information on kit contents, descriptions, and availability.

#### *CY3210-PSoCEval1*

The **CY3210-PSoCEval1** kit features an evaluation board and the MiniProg1 programming unit. The evaluation board includes an LCD module, potentiometer, LEDs, and plenty of bread-boarding space to meet all of your evaluation needs. The kit includes:

- Evaluation board with LCD module
- MiniProg programming unit
- 28-Pin CY8C29466-24PXI PDIP PSoC device sample (2)
- PSoC Designer software CD
- Getting Started Guide
- USB 2.0 cable

#### *CY3210-24X94 Evaluation Pod (EvalPod)*

PSoC EvalPods are pods that connect to the ICE In-Circuit Emulator (CY3215-DK kit) to allow debugging capability. They can also function as a standalone device without debugging capability. The EvalPod has a 28-pin DIP footprint on the bottom for easy connection to development kits or other hardware. The top of the EvalPod has prototyping headers for easy connection to the device's pins. **CY3210-24X94** provides evaluation of the CY8C24x94 PSoC device family.

## Device Programmers

All device programmers can be purchased from the Cypress Online Store.

### CY3210-MiniProg1

The **CY3210-MiniProg1** kit allows a user to program PSoC devices via the MiniProg1 programming unit. The MiniProg is a small, compact prototyping programmer that connects to the PC via a provided USB 2.0 cable. The kit includes:

- MiniProg Programming Unit
- MiniEval Socket Programming and Evaluation Board
- 28-Pin CY8C29466-24PXI PDIP PSoC Device Sample
- 28-Pin CY8C27443-24PXI PDIP PSoC Device Sample
- PSoC Designer Software CD
- Getting Started Guide
- USB 2.0 Cable

## Accessories (Emulation and Programming)

**Table 31. Emulation and Programming Accessories**

Part #	Pin Package	Flex-Pod Kit <sup>[24]</sup>	Foot Kit <sup>[25]</sup>	Adapter <sup>[26]</sup>
CY8C24894-24LFXA	56-pin QFN	<a href="#">CY3250-24X94QFN</a>	<a href="#">CY3250-56QFN-FK</a>	AS-56-28-01ML-6

### CY3207ISSP In-System Serial Programmer (ISSP)

The **CY3207ISSP** is a production programmer. It includes protection circuitry and an industrial case that is more robust than the MiniProg in a production-programming environment.

**Note:** CY3207ISSP needs special software and is not compatible with PSoC Programmer. The kit includes:

- CY3207 Programmer Unit
- PSoC ISSP Software CD
- 110 ~ 240 V Power Supply, Euro-Plug Adapter
- USB 2.0 Cable

### Notes

24. Flex-Pod kit includes a practice flex-pod and a practice PCB, in addition to two flex-pods.

25. Foot kit includes surface mount feet that are soldered to the target PCB.

26. Programming adapter converts non-DIP package to DIP footprint. Specific details and ordering information for each of the adapters are found at <http://www.emulation.com>.

## Ordering Information

**Table 32. CY8C24x94 PSoC Device's Key Features and Ordering Information**

Package	Ordering Code	Flash (Bytes)	SRAM (Bytes)	Temperature Range	Digital Blocks	Analog Blocks	Digital I/O Pins	Analog Inputs	Analog Outputs	XRES Pin
56-pin (8 × 8 mm) QFN, punched	CY8C24894-24LFXA	16 K	1 K	−40 °C to +85 °C	4	6	49	47	2	Yes
56-pin (8 × 8 mm) QFN, punched (tape and reel)	CY8C24894-24LFXAT	16 K	1 K	−40 °C to +85 °C	4	6	49	47	2	Yes

### Ordering Code Definitions

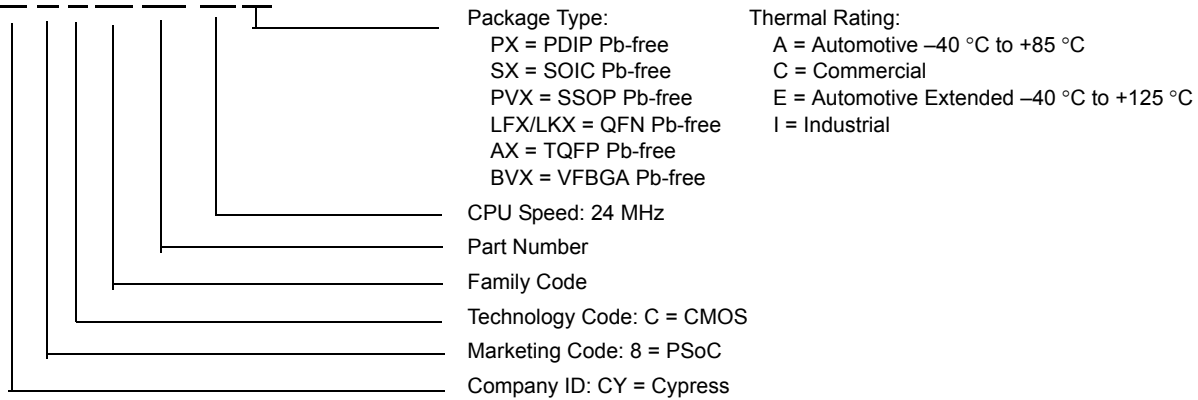
**CY 8 C 24 xxx-SPxx**

## Acronyms

Table 33 lists the acronyms that are used in this document.

**Table 33. Acronyms Used in this Datasheet**

Acronym	Description	Acronym	Description
AC	alternating current	MIPS	million instructions per second
ADC	analog-to-digital converter	PCB	printed circuit board
AEC	Automotive Electronics Council	PDIP	plastic dual in-line package
API	application programming interface	PLL	phase-locked loop
CPU	central processing unit	POR	power-on reset
CRC	cyclic redundancy check	PPOR	precision POR
CT	continuous time	PSoC®	Programmable System-on-Chip
DAC	digital-to-analog converter	PWM	pulse-width modulator
DC	direct current or duty cycle	QFN	quad flat no leads
DTMF	dual-tone multi-frequency	RMS	root mean square
EEPROM	electrically erasable programmable read-only memory	SAR	successive approximation register
EXTCLK	external clock	SC	switched capacitor
GPIO	general purpose I/O	SCL / SCLK	serial clock
I <sup>2</sup> C	inter-integrated circuit	SDA	serial data
ICE	in-circuit emulator	SLIMO	slow IMO
IDE	integrated development environment	SMP	switch mode pump
ILO	internal low-speed oscillator	SOIC	small-outline integrated circuit
IMO	internal main oscillator	SPI	serial peripheral interface
I/O	input/output	SRAM	static random-access memory
IrDA	Infrared Data Association	SROM	supervisory read-only memory
ISSP	in-system serial programming	TQFP	thin quad flat pack
LCD	liquid crystal display	UART	universal asynchronous receiver transmitter
LED	light-emitting diode	USB	universal serial bus
LPC	low power comparator	WDT	watchdog timer
LVD	low voltage detect	XRES	external reset
MCU	microcontroller unit		

## Reference Documents

CY8CPLC20, CY8CLED16P01, CY8C29x66, CY8C27x43, CY8C24x94, CY8C24x23, CY8C24x23A, CY8C22x13, CY8C21x34, CY8C21x23, CY7C64215, CY7C603xx, CY8CNP1xx, and CYWUSB6953 PSoC® Programmable System-on-Chip Technical Reference Manual (TRM) (001-14463)

PSOC(R) 1 - Getting Started With Flash & E2PROM – AN2015 (001-40459)

Application Notes for Surface Mount Assembly of Amkor's MicroLeadFrame (MLF) Packages – available at <http://www.amkor.com>.



## Document Conventions

### Units of Measure

The following table lists the units of measure that are used in this document.

**Table 34. Units of Measure**

Symbol	Unit of Measure	Symbol	Unit of Measure
°C	degree Celsius	mV <sub>PP</sub>	millivolts peak-to-peak
dB	decibel	nA	nanoampere
fF	femtofarad	ns	nanosecond
KB	1024 bytes	nV	nanovolt
kHz	kilohertz	Ω	ohm
kΩ	kilohm	%	percent
MHz	megahertz	pA	picoampere
μA	microampere	pF	picofarad
μs	microsecond	ps	picosecond
μV	microvolt	rt-Hz	root hertz
mA	milliampere	V	volt
ms	millisecond	W	watt
mV	millivolt		

### Numeric Conventions

Hexadecimal numbers are represented with all letters in uppercase with an appended lowercase 'h' (for example, '14h' or '3Ah'). Hexadecimal numbers may also be represented by a '0x' prefix, the C coding convention. Binary numbers have an appended lowercase 'b' (for example, '01010100b' or '01000011b'). Numbers not indicated by an 'h', 'b', or '0x' are in decimal format.

### Glossary

active high	<ol style="list-style-type: none"> <li>1. A logic signal having its asserted state as the logic 1 state.</li> <li>2. A logic signal having the logic 1 state as the higher voltage of the two states.</li> </ol>
analog blocks	The basic programmable opamp circuits. These are SC (switched capacitor) and CT (continuous time) blocks. These blocks can be interconnected to provide ADCs, DACs, multi-pole filters, gain stages, and much more.
analog-to-digital converter (ADC)	A device that changes an analog signal to a digital signal of corresponding magnitude. Typically, an ADC converts a voltage to a digital number. The digital-to-analog converter (DAC) performs the reverse operation.
Application programming interface (API)	A series of software routines that comprise an interface between a computer application and lower level services and functions (for example, user modules and libraries). APIs serve as building blocks for programmers that create software applications.
asynchronous	A signal whose data is acknowledged or acted upon immediately, irrespective of any clock signal.
bandgap reference	A stable voltage reference design that matches the positive temperature coefficient of VT with the negative temperature coefficient of VBE, to produce a zero temperature coefficient (ideally) reference.
bandwidth	<ol style="list-style-type: none"> <li>1. The frequency range of a message or information processing system measured in hertz.</li> <li>2. The width of the spectral region over which an amplifier (or absorber) has substantial gain (or loss); it is sometimes represented more specifically as, for example, full width at half maximum.</li> </ol>

**Glossary** *(continued)*

bias	<ol style="list-style-type: none"> <li>1. A systematic deviation of a value from a reference value.</li> <li>2. The amount by which the average of a set of values departs from a reference value.</li> <li>3. The electrical, mechanical, magnetic, or other force (field) applied to a device to establish a reference level to operate the device.</li> </ol>
block	<ol style="list-style-type: none"> <li>1. A functional unit that performs a single function, such as an oscillator.</li> <li>2. A functional unit that may be configured to perform one of several functions, such as a digital PSoC block or an analog PSoC block.</li> </ol>
buffer	<ol style="list-style-type: none"> <li>1. A storage area for data that is used to compensate for a speed difference, when transferring data from one device to another. Usually refers to an area reserved for I/O operations, into which data is read, or from which data is written.</li> <li>2. A portion of memory set aside to store data, often before it is sent to an external device or as it is received from an external device.</li> <li>3. An amplifier used to lower the output impedance of a system.</li> </ol>
bus	<ol style="list-style-type: none"> <li>1. A named connection of nets. Bundling nets together in a bus makes it easier to route nets with similar routing patterns.</li> <li>2. A set of signals performing a common function and carrying similar data. Typically represented using vector notation; for example, address[7:0].</li> <li>3. One or more conductors that serve as a common connection for a group of related devices.</li> </ol>
clock	The device that generates a periodic signal with a fixed frequency and duty cycle. A clock is sometimes used to synchronize different logic blocks.
comparator	An electronic circuit that produces an output voltage or current whenever two input levels simultaneously satisfy predetermined amplitude requirements.
compiler	A program that translates a high level language, such as C, into machine language.
configuration space	In PSoC devices, the register space accessed when the XIO bit, in the CPU_F register, is set to '1'.
crystal oscillator	An oscillator in which the frequency is controlled by a piezoelectric crystal. Typically a piezoelectric crystal is less sensitive to ambient temperature than other circuit components.
cyclic redundancy check (CRC)	A calculation used to detect errors in data communications, typically performed using a linear feedback shift register. Similar calculations may be used for a variety of other purposes such as data compression.
data bus	A bi-directional set of signals used by a computer to convey information from a memory location to the central processing unit and vice versa. More generally, a set of signals used to convey data between digital functions.
debugger	A hardware and software system that allows you to analyze the operation of the system under development. A debugger usually allows the developer to step through the firmware one step at a time, set break points, and analyze memory.
dead band	A period of time when neither of two or more signals are in their active state or in transition.
digital blocks	The 8-bit logic blocks that can act as a counter, timer, serial receiver, serial transmitter, CRC generator, pseudo-random number generator, or SPI.
digital-to-analog converter (DAC)	A device that changes a digital signal to an analog signal of corresponding magnitude. The analog-to-digital converter (ADC) performs the reverse operation.

## Glossary (continued)

duty cycle	The relationship of a clock period high time to its low time, expressed as a percent.
emulator	Duplicates (provides an emulation of) the functions of one system with a different system, so that the second system appears to behave like the first system.
external reset (XRES)	An active high signal that is driven into the PSoC device. It causes all operation of the CPU and blocks to stop and return to a pre-defined state.
flash	An electrically programmable and erasable, non-volatile technology that provides you the programmability and data storage of EPROMs, plus in-system erasability. Non-volatile means that the data is retained when power is off.
flash block	The smallest amount of flash ROM space that may be programmed at one time and the smallest amount of flash space that may be protected.
frequency	The number of cycles or events per unit of time, for a periodic function.
gain	The ratio of output current, voltage, or power to input current, voltage, or power, respectively. Gain is usually expressed in dB.
I <sup>2</sup> C	A two-wire serial computer bus by Philips Semiconductors (now NXP Semiconductors). It is used to connect low-speed peripherals in an embedded system. The original system was created in the early 1980s as a battery control interface, but it was later used as a simple internal bus system for building control electronics. I <sup>2</sup> C uses only two bi-directional pins, clock and data, both running at the V <sub>DD</sub> supply voltage and pulled high with resistors. The bus operates up to 100 kbits/second in standard mode and 400 kbits/second in fast mode.
ICE	The in-circuit emulator that allows you to test the project in a hardware environment, while viewing the debugging device activity in a software environment (PSoC Designer).
input/output (I/O)	A device that introduces data into or extracts data from a system.
interrupt	A suspension of a process, such as the execution of a computer program, caused by an event external to that process, and performed in such a way that the process can be resumed.
interrupt service routine (ISR)	A block of code that normal code execution is diverted to when the CPU receives a hardware interrupt. Many interrupt sources may each exist with its own priority and individual ISR code block. Each ISR code block ends with the RETI instruction, returning the device to the point in the program where it left normal program execution.
jitter	<ol style="list-style-type: none"> <li>1. A misplacement of the timing of a transition from its ideal position. A typical form of corruption that occurs on serial data streams.</li> <li>2. The abrupt and unwanted variations of one or more signal characteristics, such as the interval between successive pulses, the amplitude of successive cycles, or the frequency or phase of successive cycles.</li> </ol>
low voltage detect (LVD)	A circuit that senses V <sub>DD</sub> and provides an interrupt to the system when V <sub>DD</sub> falls below a selected threshold.
M8C	An 8-bit Harvard-architecture microprocessor. The microprocessor coordinates all activity inside a PSoC by interfacing to the flash, SRAM, and register space.
master device	A device that controls the timing for data exchanges between two devices. Or when devices are cascaded in width, the master device is the one that controls the timing for data exchanges between the cascaded devices and an external interface. The controlled device is called the <i>slave device</i> .

## Glossary (continued)

microcontroller	An integrated circuit chip that is designed primarily for control systems and products. In addition to a CPU, a microcontroller typically includes memory, timing circuits, and I/O circuitry. The reason for this is to permit the realization of a controller with a minimal quantity of chips, thus achieving maximal possible miniaturization. This in turn, reduces the volume and the cost of the controller. The microcontroller is normally not used for general-purpose computation as is a microprocessor.
mixed-signal	The reference to a circuit containing both analog and digital techniques and components.
modulator	A device that imposes a signal on a carrier.
noise	<ol style="list-style-type: none"><li>1. A disturbance that affects a signal and that may distort the information carried by the signal.</li><li>2. The random variations of one or more characteristics of any entity such as voltage, current, or data.</li></ol>
oscillator	A circuit that may be crystal controlled and is used to generate a clock frequency.
parity	A technique for testing transmitted data. Typically, a binary digit is added to the data to make the sum of all the digits of the binary data either always even (even parity) or always odd (odd parity).
phase-locked loop (PLL)	An electronic circuit that controls an <i>oscillator</i> so that it maintains a constant phase angle relative to a reference signal.
pinouts	The pin number assignment: the relation between the logical inputs and outputs of the PSoC device and their physical counterparts in the printed circuit board (PCB) package. Pinouts involve pin numbers as a link between schematic and PCB design (both being computer generated files) and may also involve pin names.
port	A group of pins, usually eight.
power-on reset (POR)	A circuit that forces the PSoC device to reset when the voltage is below a pre-set level. This is one type of hardware reset.
PSoC <sup>®</sup>	Cypress Semiconductor's PSoC <sup>®</sup> is a registered trademark and Programmable System-on-Chip <sup>™</sup> is a trademark of Cypress.
PSoC Designer <sup>™</sup>	The software for Cypress' Programmable System-on-Chip technology.
pulse width modulator (PWM)	An output in the form of duty cycle which varies as a function of the applied value.
RAM	An acronym for random access memory. A data-storage device from which data can be read out and new data can be written in.
register	A storage device with a specific capacity, such as a bit or byte.
reset	A means of bringing a system back to a known state. See hardware reset and software reset.
ROM	An acronym for read only memory. A data-storage device from which data can be read out, but new data cannot be written in.
serial	<ol style="list-style-type: none"><li>1. Pertaining to a process in which all events occur one after the other.</li><li>2. Pertaining to the sequential or consecutive occurrence of two or more related activities in a single device or channel.</li></ol>
settling time	The time it takes for an output signal or value to stabilize after the input has changed from one value to another.

**Glossary** (continued)

shift register	A memory storage device that sequentially shifts a word either left or right to output a stream of serial data.
slave device	A device that allows another device to control the timing for data exchanges between two devices. Or when devices are cascaded in width, the slave device is the one that allows another device to control the timing of data exchanges between the cascaded devices and an external interface. The controlling device is called the master device.
SRAM	An acronym for static random access memory. A memory device where you can store and retrieve data at a high rate of speed. The term static is used because, after a value is loaded into an SRAM cell, it remains unchanged until it is explicitly altered or until power is removed from the device.
SROM	An acronym for supervisory read only memory. The SROM holds code that is used to boot the device, calibrate circuitry, and perform flash operations. The functions of the SROM may be accessed in normal user code, operating from flash.
stop bit	A signal following a character or block that prepares the receiving device to receive the next character or block.
synchronous	<ol style="list-style-type: none"> <li>1. A signal whose data is not acknowledged or acted upon until the next active edge of a clock signal.</li> <li>2. A system whose operation is synchronized by a clock signal.</li> </ol>
tri-state	A function whose output can adopt three states: 0, 1, and Z (high-impedance). The function does not drive any value in the Z state and, in many respects, may be considered to be disconnected from the rest of the circuit, allowing another output to drive the same net.
UART	A UART or universal asynchronous receiver-transmitter translates between parallel bits of data and serial bits.
user modules	Pre-built, pre-tested hardware/firmware peripheral functions that take care of managing and configuring the lower level analog and digital PSoC blocks. User modules also provide high level API ( <i>Application Programming Interface</i> ) for the peripheral function.
user space	The bank 0 space of the register map. The registers in this bank are more likely to be modified during normal program execution and not just during initialization. Registers in bank 1 are most likely to be modified only during the initialization phase of the program.
$V_{DD}$	A name for a power net meaning "voltage drain." The most positive power supply signal. Usually 5 V or 3.3 V.
$V_{SS}$	A name for a power net meaning "voltage source." The most negative power supply signal.
watchdog timer	A timer that must be serviced periodically. If it is not serviced, the CPU resets after a specified period of time.

## Errata

This section describes the errata for the CY8C24x94 device. Details include errata trigger conditions, scope of impact, available workaround, and silicon revision applicability. Contact your local Cypress Sales Representative if you have questions.

### Part Numbers Affected

Part Number
CY8C24x94

### CY8C24x94 Errata Summary

The following table defines the errata applicability to available devices.

Items	Part Number
1. The DP line of the USB interface may pulse low when the PSoC device wakes from sleep causing an unexpected wake-up of the host computer.	CY8C24x94
2. Invalid Flash reads may occur if Vdd is pulled to -0.5 V just before power on.	CY8C24x94
3. PMA Index Register fails to auto-increment with CPU_Clock set to SysClk/1 (24 MHz).	CY8C24x94
4. The Internal Main Oscillator (IMO) frequency parameter (FIMO245V) may increase over a period of time during usage in the field and exceed the maximum spec limit of 24.96 MHz.	CY8C24x94

#### 1. The DP line of the USB interface may pulse low when the PSoC device wakes from sleep causing an unexpected wake-up of the host computer.

##### ■ PROBLEM DEFINITION

When the device is operating at 4.75 V to 5.25 V and the 3.3 V regulator is enabled, a short low pulse may be created on the DP signal line during device wake-up. The 15-20  $\mu$ s low pulse of the DP line may be interpreted by the host computer as a deattach or the beginning of a wake-up.

##### ■ TRIGGER CONDITION(S)

The bandgap reference voltage used by the 3.3 V regulator decreases during sleep due to leakage. Upon device wake up, the bandgap is reenabled and after a delay for settling, the 3.3 V regulator is enabled. On some devices the 3.3 V regulator that is used to generate the USB DP signal may be enabled before the bandgap is fully stabilized. This can cause a low pulse on the regulator output and DP signal line until the bandgap stabilizes. In applications where Vdd is 3.3 V, the regulator is not used and therefore the DP low pulse is not generated.

##### ■ WORKAROUND

To prevent the DP signal from pulsing low, keep the bandgap enabled during sleep. The most efficient method is to set the No Buzz bit in the OSC\_CR0 register. The No Buzz bit keeps the bandgap powered and output stable during sleep. Setting the No Buzz bit results in nominal 100  $\mu$ A increase to sleep current. Leaving the analog reference block enabled during sleep also resolves this issue because it forces the bandgap to remain enabled. An example for disabling the No Buzz bit is listed below.

##### Assembly

```
M8C_SetBank1
or reg[OSC_CR0], 0x20
M8C_SetBank0
```

##### C

```
OSC_CR0 |= 0x20;
```

## 2. Invalid Flash reads may occur if Vdd is pulled to -0.5 V just before power on.

### ■ PROBLEM DEFINITION

When Vdd of the device is pulled below ground just before power on, the first read from each 8K Flash page may be corrupted. This issue does not affect Flash page 0 because it is the selected page upon reset.

### ■ TRIGGER CONDITION(S)

When Vdd is pulled below ground before power on, an internal Flash reference may deviate from its nominal voltage. The reference deviation tends to result in the first Flash read from that page returning 0xFF. During the first read from each page, the reference is reset resulting in all future reads returning the correct value. A short delay of 5  $\mu$ s before the first real read provides time for the reference voltage to stabilize.

### ■ WORKAROUND

To prevent an invalid Flash read, a dummy read from each Flash page must occur before use of the pages. A delay of 5  $\mu$ s must occur after the dummy read and before a real read. The dummy reads occurs as soon as possible and must be located in Flash page 0 before a read from any other Flash page. An example for reading a byte of memory from each Flash page is listed below. Placed it in boot.tpl and boot.asm immediately after the 'start:' label.

```
// dummy read from each 8K Flash page
// page 1
mov  A, 0x20      // MSB
mov  X, 0x00      // LSB
romx
// wait at least 5  $\mu$ s
mov  X, 14
loop1:
dec  X
jnz  loop1
```

**3. PMA Index Register fails to auto-increment with CPU\_Clock set to SysClk/1 (24 MHz).**

**■ PROBLEM DEFINITION**

When the device is operating at 4.75 to 5.25 V and the CPU\_Clock is set to SysClk/1 (24 MHz), the USB PMA Index Register may fail to increment automatically when used in an OUT endpoint configuration at Full-Speed. When the application program attempts to use the bReadOutEP() function the first byte in the PMA buffer is always returned.

**■ TRIGGER CONDITION(S)**

An internal flip-flop hold problem associated with Index Register increment function. All reads of the associated RAM originate from the first byte. The hold problem has no impact on other circuits or functions within the device.

**■ WORKAROUND**

To make certain that the index register properly increments, set the CPU\_Clock to SysClk/2 (12 MHz) during the read of the PMA buffer. An example for the clock adjustment method is listed below.

PSoC Designer™ 4.3 User Module workaround: PSoC Designer Release 4.3 and subsequent releases includes a revised full-speed USB User Module with the revised firmware work-around included (see example below).

```
;;
;; 24 MHz read PMA workaround
;;
M8C_SetBank1
mov A, reg[OSC_CR0]
push A
and A, 0xf8 ;clear the clock bits (briefly chg the cpu_clk to 3 MHz)
or A, 0x02 ;will set clk to 12Mhz

mov reg[OSC_CR0],A ;clk is now set at 12 MHz
M8C_SetBank0
.loop:
  mov A, reg[PMA0_DR] ; Get the data from the PMA space
  mov [X], A ; save it in data array
  inc X ; increment the pointer
  dec [USB_APITemp+1] ; decrement the counter
  jnz .loop ; wait for count to zero out
;;
;; 24MHz read PMA workaround (back to previous clock speed)
;;
pop A ;recover previous reg[OSC_CR0] value
M8C_SetBank1
mov reg[OSC_CR0],A ;clk is now set at previous value
M8C_SetBank0
;;
;; end 24Mhz read PMA workaround
```



**4. The Internal Main Oscillator (IMO) frequency parameter (FIMO245V) may increase over a period of time during usage in the field and exceed the maximum spec limit of 24.96 MHz.**

■ **PROBLEM DEFINITION**

When the device has been operating at 4.75 V to 5.25 V for a cumulatively long duration in the field, the IMO Frequency may slowly increase over the duration of usage in the field and eventually exceed the maximum spec limit of 24.96 MHz. This may affect applications that are sensitive to the max value of IMO frequency, such as those using UART communication and result in a functional failure.

■ **TRIGGER CONDITION(S)**

Very long (cumulative) usage of the device in the operating voltage range of 4.75V to 5.25V, with the IMO clock running continuously, could lead to the degradation. Higher power supply voltage and lower ambient temperature are worst-case conditions for the degradation.

■ **WORKAROUND**

Operating the device with the power supply voltage range of 3.0 V to 3.6 V, would avoid the degradation of IMO Frequency beyond the max spec limit of 24.96 MHz.

■ **FIX STATUS**

A new revision of the silicon, with a fix for this issue, is expected to be available from August 1st 2015.

Document History Page

Document Title: CY8C24894 Automotive PSoC <sup>®</sup> Programmable System-on-Chip <sup>™</sup>				
Document Number: 001-53754				
Revision	ECN	Orig. of Change	Submission Date	Description of Change
**	2715097	MASJ	06/08/09	New data sheet.
*A	2782580	BTK	10/09/09	Updated Features section. Updated text of PSoC Functional Overview section. Updated Getting Started section. Made corrections and minor text edits to Pinouts section. Changed the name of some sections to improve consistency. Improved formatting of the register tables. Added clarifying comments to some electrical specifications. Fixed all AC specifications to conform to a ±4% or ±8% IMO accuracy. Made other miscellaneous minor text edits. Deleted some non-applicable or redundant information. Improved and edited content in Development Tool Selection section. Improved the bookmark structure. Changed Flash <sub>ENT</sub> , V <sub>CMOA</sub> , the DC POR and LVD specifications, and the DC Analog Reference specifications according to MASJ directives. Added T <sub>XRST</sub> , DC24M, and 3.3 V DC Operational Amplifier specifications.
*B	2822792	BTK / AESA	12/07/09	Added T <sub>PRGH</sub> , T <sub>PRGC</sub> , I <sub>OL</sub> , I <sub>OH</sub> , F <sub>32KU</sub> , DC <sub>ILO</sub> , and T <sub>POWERUP</sub> electrical specifications. Updated the footnotes of <a href="#">Table 16, "DC Programming Specifications,"</a> on page 26. Added maximum values and updated typical values for T <sub>ERASEB</sub> and T <sub>WRITE</sub> electrical specifications. Replaced T <sub>RAMP</sub> electrical specification with SR <sub>POWERUP</sub> electrical specification. Added " <a href="#">Contents</a> " on page 2.
*C	2888007	NJF	03/30/10	Updated Cypress website links. Removed reference to PSoC Designer 4.4 in <a href="#">PSoC Designer Software Subsystems</a> Updated <a href="#">The Analog System</a> . Added T <sub>BAKETEMP</sub> and T <sub>BAKETIME</sub> parameters in <a href="#">Absolute Maximum Ratings</a> . Updated <a href="#">AC Chip-Level Specifications</a> . Updated <a href="#">Packaging Information</a> . Removed Third Party Tools and Build a PSoC Emulator into your Board. Updated links in <a href="#">Sales, Solutions, and Legal Information</a> .
*D	3272922	BTK/NJF	06/02/11	Updated <a href="#">Figure 8 on page 34</a> to improve clarity. Updated wording, formatting, and notes of the <a href="#">AC Digital Block Specifications</a> table to improve clarity. Added V <sub>DDP</sub> , V <sub>DDL</sub> , and V <sub>DDHV</sub> electrical specifications to give more information for programming the device. Updated <a href="#">Solder Reflow Specifications</a> to give more clarity. Updated the jitter specifications. Updated <a href="#">PSoC Device Characteristics</a> table. Updated the F <sub>32KU</sub> electrical specification. Updated note for R <sub>PD</sub> electrical specification. Updated note for the T <sub>STG</sub> electrical specification to add more clarity. Added <a href="#">Tape and Reel Specifications</a> section. Added C <sub>L</sub> electrical specification. Updated <a href="#">DC Analog Reference Specifications</a> . Changed "NC" pins on the device to "DNC" pins. Corrected information about the exposed pad to clarify that it is not internally connected.
*E	3990974	STHA	05/06/2013	Added <a href="#">Errata</a> .

**Document History Page** *(continued)*

Document Title: CY8C24894 Automotive PSoC® Programmable System-on-Chip™ Document Number: 001-53754				
Revision	ECN	Orig. of Change	Submission Date	Description of Change
*F	4074455	STHA	07/23/2013	<p>Added Errata footnotes (Note 5, 7).</p> <p>Updated <a href="#">Electrical Specifications</a>:            Updated <a href="#">DC Electrical Characteristics</a>:            Updated <a href="#">DC Chip Level Specifications</a>:            Added Note 5 and referred the same note in "Sleep Mode" in description of I<sub>SB</sub> parameter in <a href="#">Table 5</a>.            Updated <a href="#">DC POR and LVD Specifications</a>:            Added Note 7 and referred the same note in V<sub>PPOR0</sub>, V<sub>PPOR1</sub>, V<sub>PPOR2</sub> parameters in <a href="#">Table 15</a>.</p> <p>Updated to new template.</p>
*G	4398714	KUK	06/05/2014	<p>Removed CY3280-24X94 Universal CapSense Controller Board section.            Removed reference to obsolete spec 001-14503 from <a href="#">Reference Documents</a>.</p>
*H	4684557	PSI	03/12/2015	Updated <a href="#">Errata</a> .

## Sales, Solutions, and Legal Information

### Worldwide Sales and Design Support

Cypress maintains a worldwide network of offices, solution centers, manufacturer’s representatives, and distributors. To find the office closest to you, visit us at [Cypress Locations](#).

#### Products

Automotive	<a href="http://cypress.com/go/automotive">cypress.com/go/automotive</a>
Clocks & Buffers	<a href="http://cypress.com/go/clocks">cypress.com/go/clocks</a>
Interface	<a href="http://cypress.com/go/interface">cypress.com/go/interface</a>
Lighting & Power Control	<a href="http://cypress.com/go/powerpsoc">cypress.com/go/powerpsoc</a> <a href="http://cypress.com/go/plc">cypress.com/go/plc</a>
Memory	<a href="http://cypress.com/go/memory">cypress.com/go/memory</a>
PSoC	<a href="http://cypress.com/go/psoc">cypress.com/go/psoc</a>
Touch Sensing	<a href="http://cypress.com/go/touch">cypress.com/go/touch</a>
USB Controllers	<a href="http://cypress.com/go/USB">cypress.com/go/USB</a>
Wireless/RF	<a href="http://cypress.com/go/wireless">cypress.com/go/wireless</a>

#### PSoC® Solutions

[psoc.cypress.com/solutions](http://psoc.cypress.com/solutions)  
PSoC 1 | PSoC 3 | PSoC 4 | PSoC 5LP

#### Cypress Developer Community

[Community](#) | [Forums](#) | [Blogs](#) | [Video](#) | [Training](#)

#### Technical Support

[cypress.com/go/support](http://cypress.com/go/support)

---

© Cypress Semiconductor Corporation, 2004-2015. The information contained herein is subject to change without notice. Cypress Semiconductor Corporation assumes no responsibility for the use of any circuitry other than circuitry embodied in a Cypress product. Nor does it convey or imply any license under patent or other rights. Cypress products are not warranted nor intended to be used for medical, life support, life saving, critical control or safety applications, unless pursuant to an express written agreement with Cypress. Furthermore, Cypress does not authorize its products for use as critical components in life-support systems where a malfunction or failure may reasonably be expected to result in significant injury to the user. The inclusion of Cypress products in life-support systems application implies that the manufacturer assumes all risk of such use and in doing so indemnifies Cypress against all charges.

Any Source Code (software and/or firmware) is owned by Cypress Semiconductor Corporation (Cypress) and is protected by and subject to worldwide patent protection (United States and foreign), United States copyright laws and international treaty provisions. Cypress hereby grants to licensee a personal, non-exclusive, non-transferable license to copy, use, modify, create derivative works of, and compile the Cypress Source Code and derivative works for the sole purpose of creating custom software and or firmware in support of licensee product to be used only in conjunction with a Cypress integrated circuit as specified in the applicable agreement. Any reproduction, modification, translation, compilation, or representation of this Source Code except as specified above is prohibited without the express written permission of Cypress.

Disclaimer: CYPRESS MAKES NO WARRANTY OF ANY KIND, EXPRESS OR IMPLIED, WITH REGARD TO THIS MATERIAL, INCLUDING, BUT NOT LIMITED TO, THE IMPLIED WARRANTIES OF MERCHANTABILITY AND FITNESS FOR A PARTICULAR PURPOSE. Cypress reserves the right to make changes without further notice to the materials described herein. Cypress does not assume any liability arising out of the application or use of any product or circuit described herein. Cypress does not authorize its products for use as critical components in life-support systems where a malfunction or failure may reasonably be expected to result in significant injury to the user. The inclusion of Cypress’ product in a life-support systems application implies that the manufacturer assumes all risk of such use and in doing so indemnifies Cypress against all charges.

Use may be limited by and subject to the applicable Cypress software license agreement.