

SYMBOL DEFINITION		MISSING SYMBOLS	
A DIMENSION WITHOUT AN INSPECTION REPORT SYMBOL DOES NOT REQUIRE INSPECTION. IT MAY BE CONTROLLED ON THE INDIVIDUAL COMPONENT DRAWING.	TOTAL NO OF INSPECTIONS REQUIRED	NO MISSING SYMBOL NUMBER	
	28		
	LAST NO. USED		
	28		

DWG STATUS				ZONE	REVISION HISTORY	AUTH	DR	APVD1	APVD2
DATE	STG	REV	N/P						
30JUN99	R	01	-	-	WAS PE071022, REVISED AND RELEASED	990005	RGV	RMM	PHA
29MR00	R	02	-	-	REVISED GRAPHICS	199443	CRW	MVA	PHA
16JA01	R	02	AA	-	UPDATED PDM ATTRIBUTES	205846	TLD	TLD	CSD
08MR01	R	02	AB	-	INCREASED RIB HEIGHT (2 PLCS)	207141	JLJ	JLJ	CSD
27JN01	R	02	AC	-	UPDATED PDM ATTRIBUTES	210565	TSH	TSH	CSD
28MR03	R	03	-	-	(11.3) WAS (13.3) & MAT'L SPEC WAS R0071753	237998	FKV	FKV	CSD
13AU04	R	03	AA	-	UPDATED PDM ATTRIBUTES	257950	ADK	ADK	CD
02FE07	R	04	-	-	MAT'L SPEC WAS M3592002	400399	EFV	JVM	GGI
05MY11	R	04	AA	-	INSPECTION SYMBOLS UPDATED & REDRAWN TO TAXI 13885453	414163	CM	CM	MC

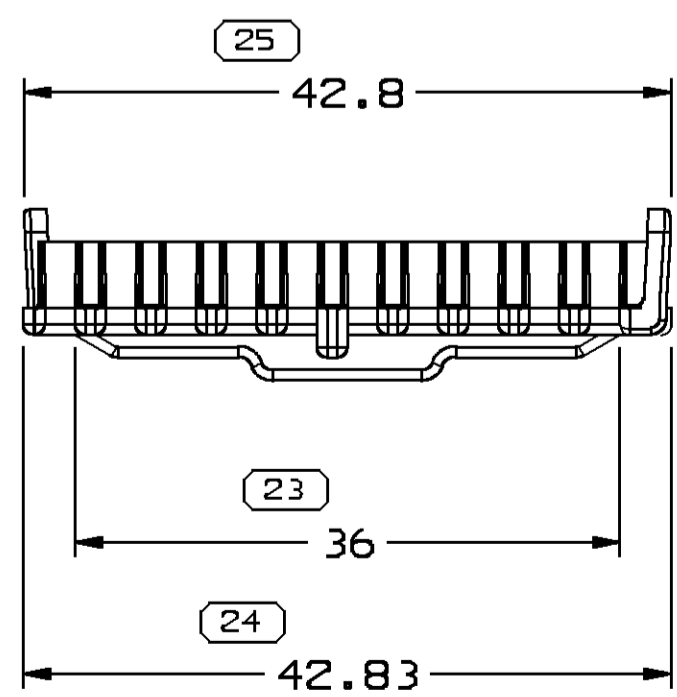
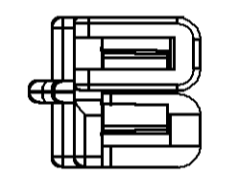
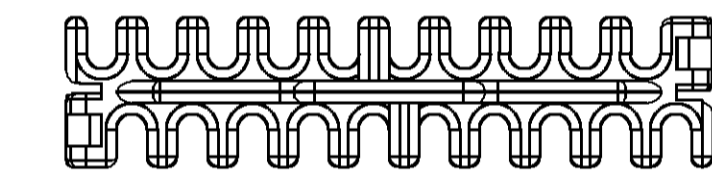
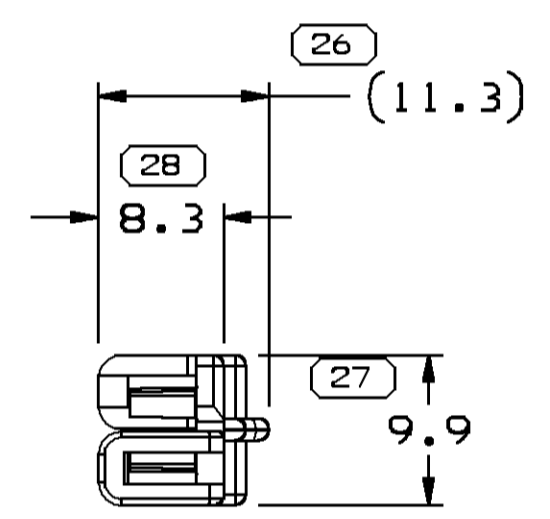
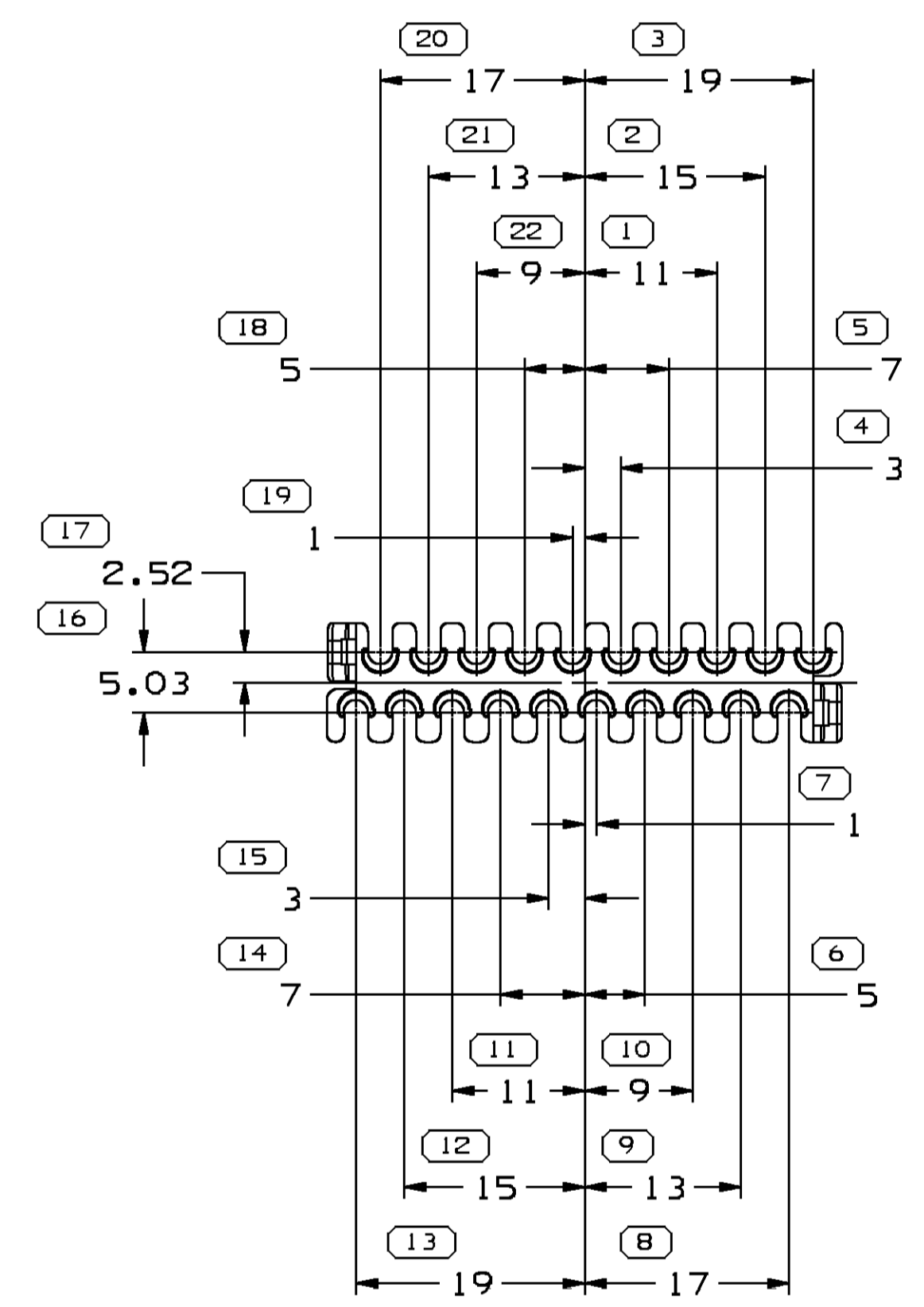
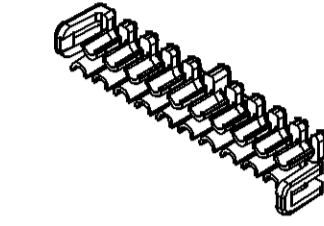
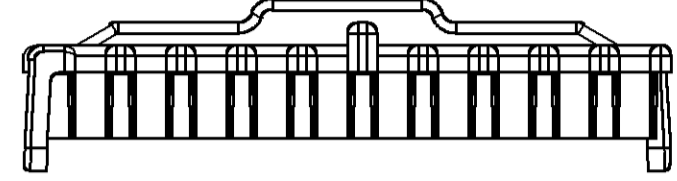

NOTES

- UNLESS OTHERWISE SPECIFIED AND/OR INDICATED:  
DIMENSIONS ARE TO FACE OF VIEW SHOWN AND AUTOMATICALLY ROUNDED BY COMPUTER FOR INSPECTION (SEE MATH MODEL FOR PRECISE DIMENSIONS). FOR ALL OTHER DIMENSIONS NOT SHOWN BUT REQUIRED FOR TOOL BUILD, SEE MATH MODEL FOR PRECISE TOOL PATH DATA.
- MATERIAL RECYCLING CODE PER ISO 11469. (1.5)X(0.1) CHARACTERS AS SHOWN TO BE LOCATED ON ANY EXTERIOR SURFACE. OPTIONAL CONSTRUCTION TO BE NO MATERIAL RECYCLING CODE.
- THIS PART IS NOT CONTROLLED FOR AUTOMATIC FEEDING.
- REFERENCE MATING COMPONENTS OR EQUIVALENT:  
ASM 15355368
- (1.5)X(0.1) RAISED DELPHI CORPORATE BRAND TO BE LOCATED ON ANY EXTERIOR SURFACE, PREFERABLY VISIBLE AT FINAL ASSEMBLY. OPTIONAL CONSTRUCTION TO BE "PED" OR NO LOGO.

(23) PROCESS SENSITIVE DIMENSION	
DIMENSIONS ENCLOSED IN ( ) INDICATE REFERENCE DIMENSIONS AND NO TOLERANCE LIMITS ARE ESTABLISHED	
DIMENSIONAL RANGE (MM)	CHART E1
FROM > 0	> 20
TO > 20	> 30
> 30	> 70
> 70	> 100
> 100	> 150
> 150	> 200
> 200	> 250
> 250	> 300
> 300	> 400
TOLERANCE UNLESS OTHERWISE SPECIFIED	
±0.15	±0.2
±0.3	±0.4
±0.5	±0.6
±0.8	±1
±1	±1.2
ANGULAR TOLERANCE ±2°	

DWG TYPE PART DRAWING	
STYLE	
VOLUME (CPI) 0.869	DISTR CODE D
UNLESS OTHERWISE SPECIFIED THIS DOCUMENT IS IN ACCORDANCE WITH ASME Y14.5M-1994 AS AMENDED BY THE 0M GLOBAL DIMENSIONING AND TOLERANCING ADDENDUM - 1997. ALL GEOMETRIC TOLERANCES AND RELATED DATUMS APPLY RFS. RULE #1 (PERFECT FORM AT MMPI) DOES NOT APPLY WHEN RELATIONSHIP BETWEEN FEATURES IS ESTABLISHED BY ORIENTATION OR LOCATION TOLERANCES. SEPARATE POSITION CALLOUTS MAY BE GAGED SEPARATELY, REGARDLESS OF DATUM REFERENCE. ALL DIMENSIONS ARE IN MILLIMETERS	
REFERENCE	
THIRD ANGLE PROJECTION	DO NOT SCALE
USE MATH DATA	NX

**DELPHI**  
DELPHI PACKARD ELECTRICAL/ELECTRONIC ARCHITECTURE  
WARREN, OH

DR	DATE
APVD1 R. GUERRERO	30JUN99
APVD2 L.R. MOYSEN	01JUL99
APVD3 PAUL ALAKSIN	13AU99
APVD4	
APVD5	

SUBSTANCES OF CONCERN AND RECYCLED CONTENT PER DELPHI 10949001

MATERIAL  
M3592024 PA66 HS IM CRM

DRAWING NAME  
LOCK SECONDARY TPA 6T

DRAWING NUMBER  
15366676

SIZE A1	SCALE 2:1	FRAME NO 1 OF 1	SHEET NO 1 OF 1	STG R	REV 04	N/P AA
------------	--------------	--------------------	--------------------	----------	-----------	-----------