

SYMBOL DEFINITION		MISSING SYMBOLS	
A DIMENSION WITHOUT AN INSPECTION REPORT SYMBOL () DOES NOT REQUIRE INSPECTION. IT MAY BE CONTROLLED ON THE INDIVIDUAL COMPONENT DRAWING.	TOTAL NO OF INSPECTIONS REQUIRED	NO MISSING SYMBOL NUMBER	57
	LAST NO. USED		11

DWG STATUS				REVISION HISTORY				AUTH		DR		APVD	
DATE	STG	REV	N/P	CHG	ZONE								
26APO2	R	01	AA	-		CLEARED REV COL & REVISED TOLERANCE - 3PLCS	224658	CJC	CJC	JM			
01MR06	R	01	AB	-		UPDATED PDM ATTRIBUTES	277619	TS	TS	EJH			

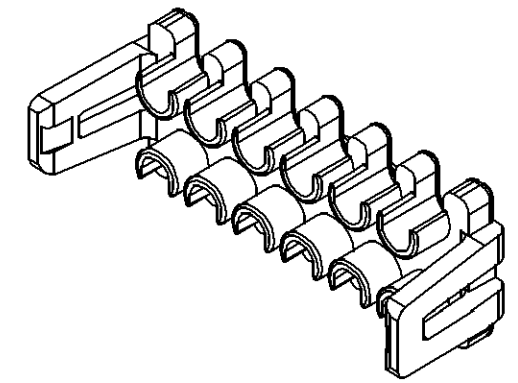
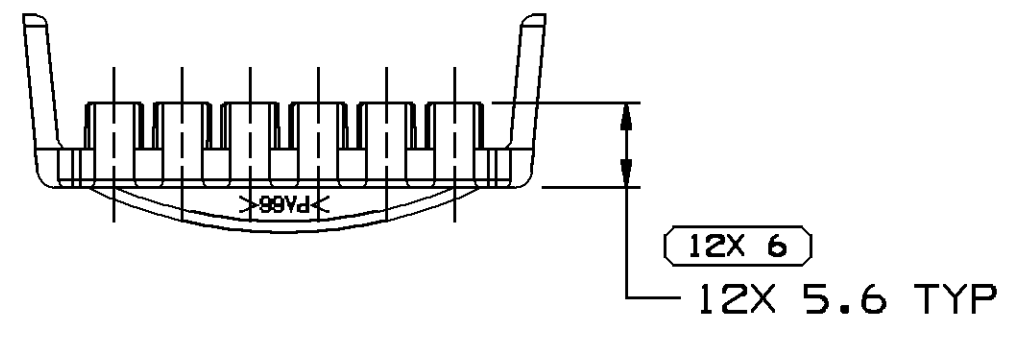
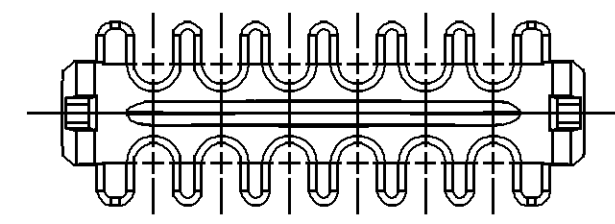
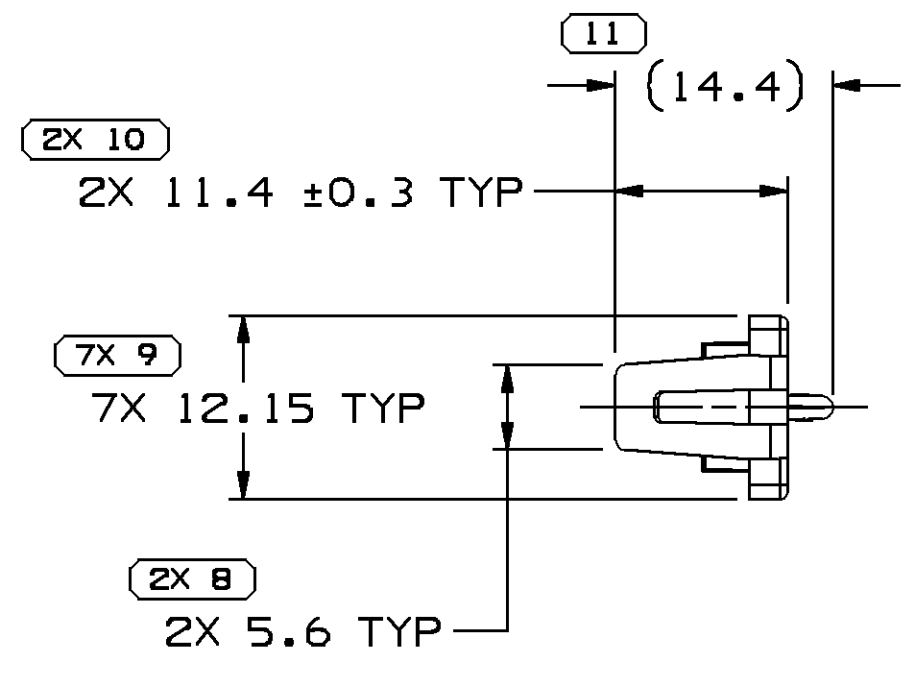
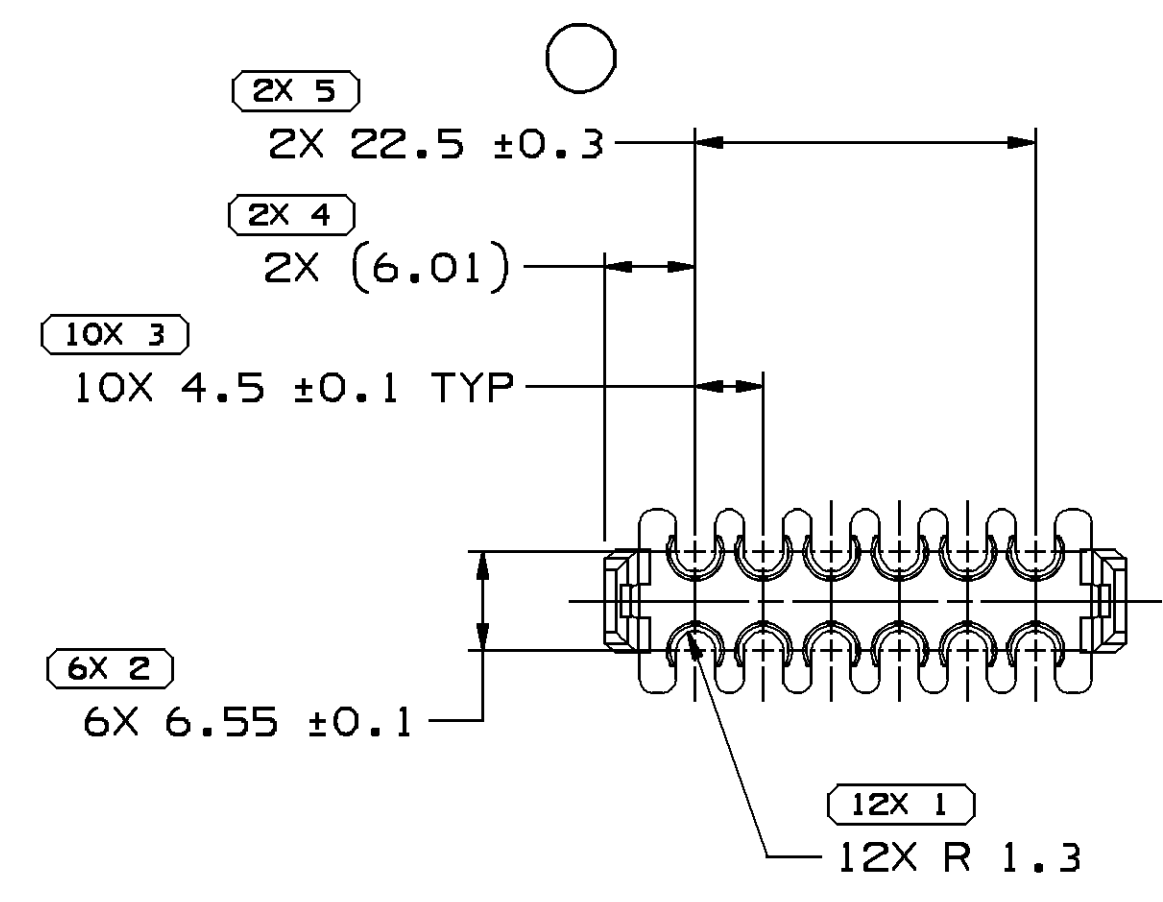
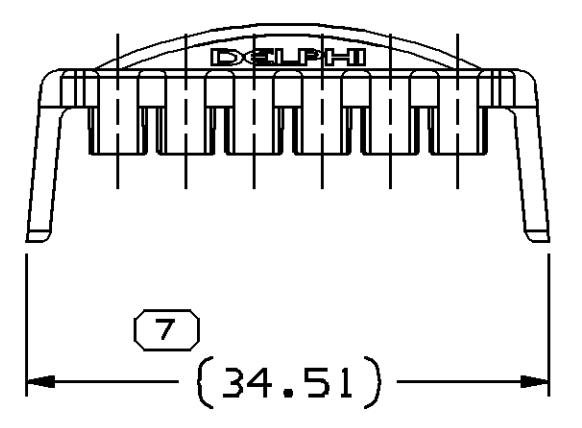

VIEW SCALE DOES NOT REFLECT ACTUAL PART SIZE

- NOTES
- UNLESS OTHERWISE SPECIFIED AND/OR INDICATED: DIMENSIONS ARE TO FACE OF VIEW SHOWN AND AUTOMATICALLY ROUNDED BY COMPUTER FOR INSPECTION (SEE MATH MODEL FOR PRECISE DIMENSIONS). FOR ALL OTHER DIMENSIONS NOT SHOWN BUT REQUIRED FOR TOOL BUILD, SEE MATH MODEL FOR PRECISE TOOL PATH DATA.
 - MATERIAL RECYCLING CODE >PA66< PER SAE J1344. (1)X(0.1) RAISED CHARACTERS AS SHOWN TO BE LOCATED ON ANY EXTERIOR SURFACE. OPTIONAL CONSTRUCTION TO BE NO MATERIAL RECYCLING CODE.
 - THIS PART IS NOT CONTROLLED FOR AUTOMATIC FEEDING.
 - MATING COMPONENTS OR EQUIVALENT: 15326849 & 15326854
 - (1)X(0.1) RAISED DELPHI CORPORATE BRAND TO BE LOCATED ON ANY EXTERIOR SURFACE, PREFERABLY VISIBLE AT FINAL ASSEMBLY. OPTIONAL CONSTRUCTION TO BE "PED" OR NO LOGO.

(6) PROCESS SENSITIVE DIMENSION
DIMENSIONS ENCLOSED IN () INDICATE REFERENCE DIMENSIONS AND NO TOLERANCE LIMITS ARE ESTABLISHED

DIMENSIONAL RANGE (MM)		CHART E1	
FROM	TO	>	>
0	20	20	30
20	30	30	70
30	70	70	100
70	100	100	150
100	150	150	200
150	200	200	250
200	250	250	300
250	300	300	400

TOLERANCE UNLESS OTHERWISE SPECIFIED
±0.15 | ±0.2 | ±0.3 | ±0.4 | ±0.5 | ±0.6 | ±0.8 | ±1 | ±1.2
ANGULAR TOLERANCE ±2°

DWG TYPE PART DRAWING	
STYLE	
VOLUME (CM³) 0.859	DISTR CODE D
UNLESS OTHERWISE SPECIFIED THIS DOCUMENT IS IN ACCORDANCE WITH ASME Y14.5M-1994 AS AMENDED BY THE 3M GLOBAL DIMENSIONING AND TOLERANCING ADDENDUM - 1997. ALL GEOMETRIC TOLERANCES AND RELATED DATUMS APPLY RFS. RULE #1 (PERFECT FORM AT MMC) DOES NOT APPLY WHEN RELATIONSHIP BETWEEN FEATURES IS ESTABLISHED BY ORIENTATION OR LOCATION TOLERANCES. SEPARATE POSITION CALLOUTS MAY BE GAGED SEPARATELY, REGARDLESS OF DATUM REFERENCE. ALL DIMENSIONS ARE IN MILLIMETERS	
REFERENCE	
THIRD ANGLE PROJECTION	DO NOT SCALE USE MATH DATA
UNIGRAPHICS	

DELPHI	
DELPHI PACKARD ELECTRIC SYSTEMS WARREN, OH	
DR	DATE
APVD1 ELIAS VAZQUEZ V.	07MR02
APVD2 ELIAS VAZQUEZ V.	07MR02
APVD3 J. S. MENDENHALL	08MR02
APVD4	
APVD5	
SUBSTANCES OF CONCERN AND RECYCLED CONTENT PER DELPHI-A 10949001	
MATERIAL M3592009 PA66 HS 1M-PPL	
DRAWING NAME LOCK TPA GT 150 PPL	
DRAWING NUMBER 15430903	
SIZE A1	SCALE 2:1
FRAME NO 1 OF 1	SHEET NO 1 OF 1
STG R	REV 01
N/P AB	APVD AB