

SYMBOL DEFINITION	
A DIMENSION WITHOUT AN INSPECTION REPORT SYMBOL  DOES NOT REQUIRE INSPECTION. IT MAY BE CONTROLLED ON THE INDIVIDUAL COMPONENT DRAWING.	TOTAL NO OF INSPECTIONS REQUIRED
	32
	LAST NO. USED
	11

MISSING SYMBOLS	
NO MISSING SYMBOL NUMBER	

DWG STATUS					ZONE	REVISION HISTORY	AUTH	DR	APVD 1	APVD 2
DATE	STG	REV	N/P	CHG						
280C03	R	01	-	-		WAS PE106161 AND RELEASED	248097	MAC	MAC	CD
22DE03	R	01	AA	-		PROCESS SENSITIVE DIM WAS DIM 4; UPDATED PDM ATTRIBUTES	250228	ADK	ADK	CD
11FE04	R	01	AB	-		REVISED TOL (1 PLC)	251133	JTZ	FKV	CD

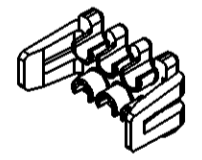
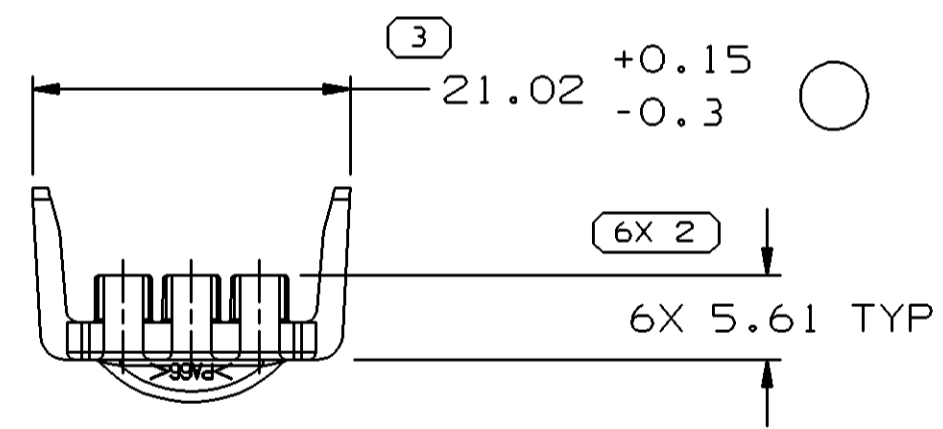
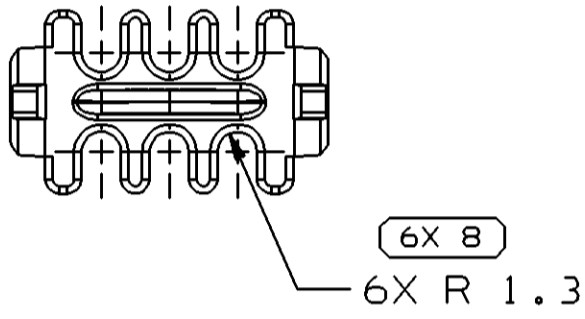
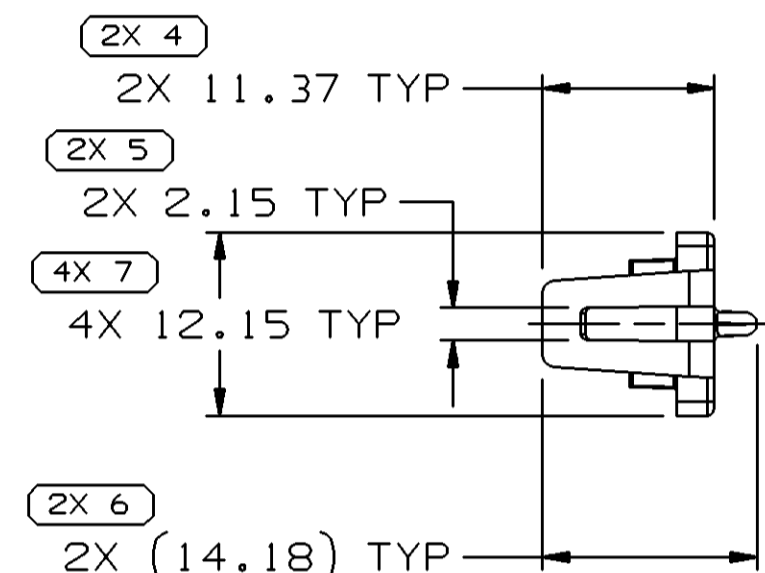
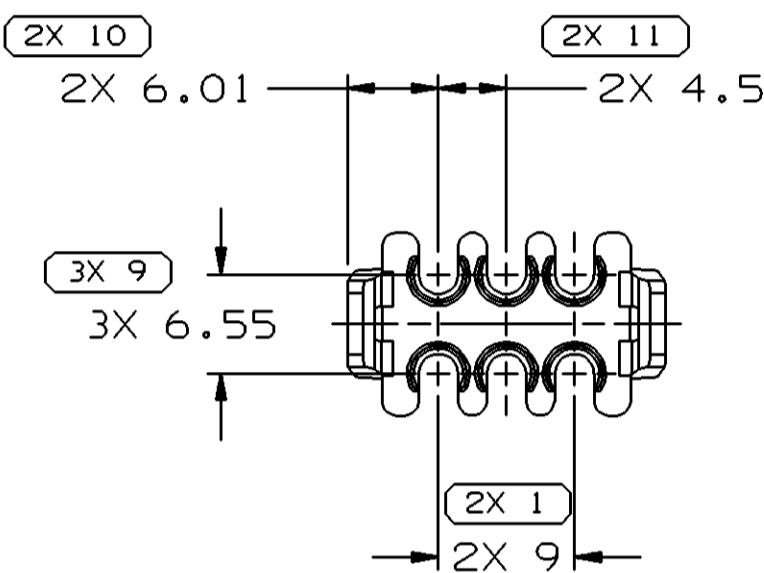
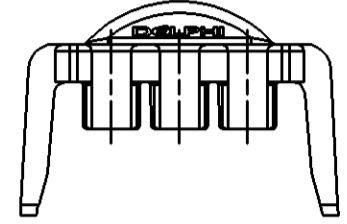

NOTES

- UNLESS OTHERWISE SPECIFIED AND/OR INDICATED: DIMENSIONS ARE TO FACE OF VIEW SHOWN AND AUTOMATICALLY ROUNDED BY COMPUTER FOR INSPECTION (SEE MATH MODEL FOR PRECISE DIMENSIONS). FOR ALL OTHER DIMENSIONS NOT SHOWN BUT REQUIRED FOR TOOL BUILD, SEE MATH MODEL FOR PRECISE TOOL PATH DATA.
- THIS PART USED ON CONN ASSEMBLY 15355297.
- MATERIAL RECYCLING CODE PER ISO 11469. (1)X(0.1) RAISED CHARACTERS AS SHOWN TO BE LOCATED ON ANY EXTERIOR SURFACE. OPTIONAL CONSTRUCTION TO BE NO MATERIAL RECYCLING CODE.
- THIS PART IS NOT CONTROLLED FOR AUTOMATIC FEEDING.
- (0.6)X(0.1) RAISED DELPHI CORPORATE BRAND TO BE LOCATED ON ANY EXTERIOR SURFACE, PREFERABLY VISIBLE AT FINAL ASSEMBLY. OPTIONAL CONSTRUCTION TO BE "PED" OR NO LOGO.

DWG TYPE		PART DRAWING	
STYLE			
VOLUME (CM <sup>3</sup> )	0.613	DISTR CODE	D
ROUTING	6900		
UNLESS OTHERWISE SPECIFIED			
THIS DOCUMENT IS IN ACCORDANCE WITH ASME Y14.5M-1994 AS AMENDED BY THE GM GLOBAL DIMENSIONING AND TOLERANCING ADDENDUM - 1997. ALL GEOMETRIC TOLERANCES AND RELATED DATUMS APPLY RFS. RULE #1 (PERFECT FORM AT MMC) DOES NOT APPLY WHEN RELATIONSHIP BETWEEN FEATURES IS ESTABLISHED BY ORIENTATION OR LOCATION TOLERANCES. SEPARATE POSITION CALLOUTS MAY BE GAGED SEPARATELY, REGARDLESS OF DATUM REFERENCE.			
ALL DIMENSIONS ARE IN MILLIMETERS			
REFERENCE			

**DELPHI**

DELPHI PACKARD ELECTRIC SYSTEMS  
WARREN, OH

DATE	
DR	
APVD1	M. CHRESTAY 280C03
APVD2	M. CHRESTAY 280C03
APVD3	CHRIS DEPROFIO 300C03
APVD4	
APVD5	

SUBSTANCES OF CONCERN AND RECYCLED CONTENT PER DELPHI 10949001

MATERIAL M3592009 PA66 HS 1M PPL

DRAWING NAME  
LOCK TPA GT 150 6 PPL

DRAWING NUMBER  
**15483798**

SIZE	SCALE	FRAME NO	SHEET NO	STG	REV	N/P
A2	2:1	1 OF 1	1 OF 1	R	01	AB

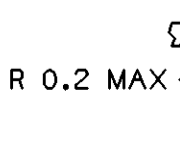
 R 0.2 MAX R 0.1 MAX SHARP CORNER TOLERANCE	DIMENSIONAL RANGE (MM)										CHART E1
	FROM	> 0	> 20	> 30	> 70	> 100	> 150	> 200	> 250	> 300	> 400
TO	20	30	70	100	150	200	250	300	400		
TOLERANCE UNLESS OTHERWISE SPECIFIED											
±0.15 ±0.2 ±0.3 ±0.4 ±0.5 ±0.6 ±0.8 ±1 ±1.2											
ANGULAR TOLERANCE ±2°											

THIRD ANGLE PROJECTION

DO NOT SCALE

USE MATH DATA

