

D

THIS DRAWING AND/OR ELECTRONIC FILE, AND THE DESIGN HEREON, CONSTITUTES A PROPRIETARY DESIGN OF DELPHI PACKARD ELECTRIC SYSTEMS.  
DO NOT SCALE

PART NO  
1203 4147

DATE	SYM	REVISION RECORD	AUTH	DR	CK
17AP97	A2	REDRAWN & REMOVED CAVITY			
		LETTERS	175483	EML	RFC
17AP97	A3	12034146 CONN REVISED	179650	EML	RFC

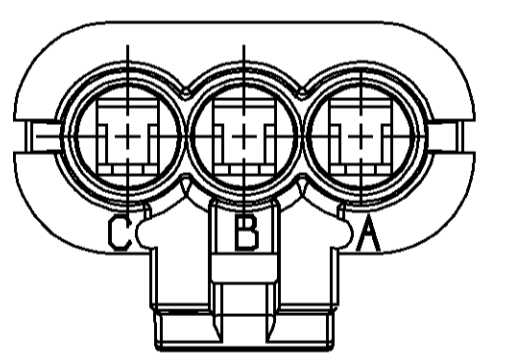
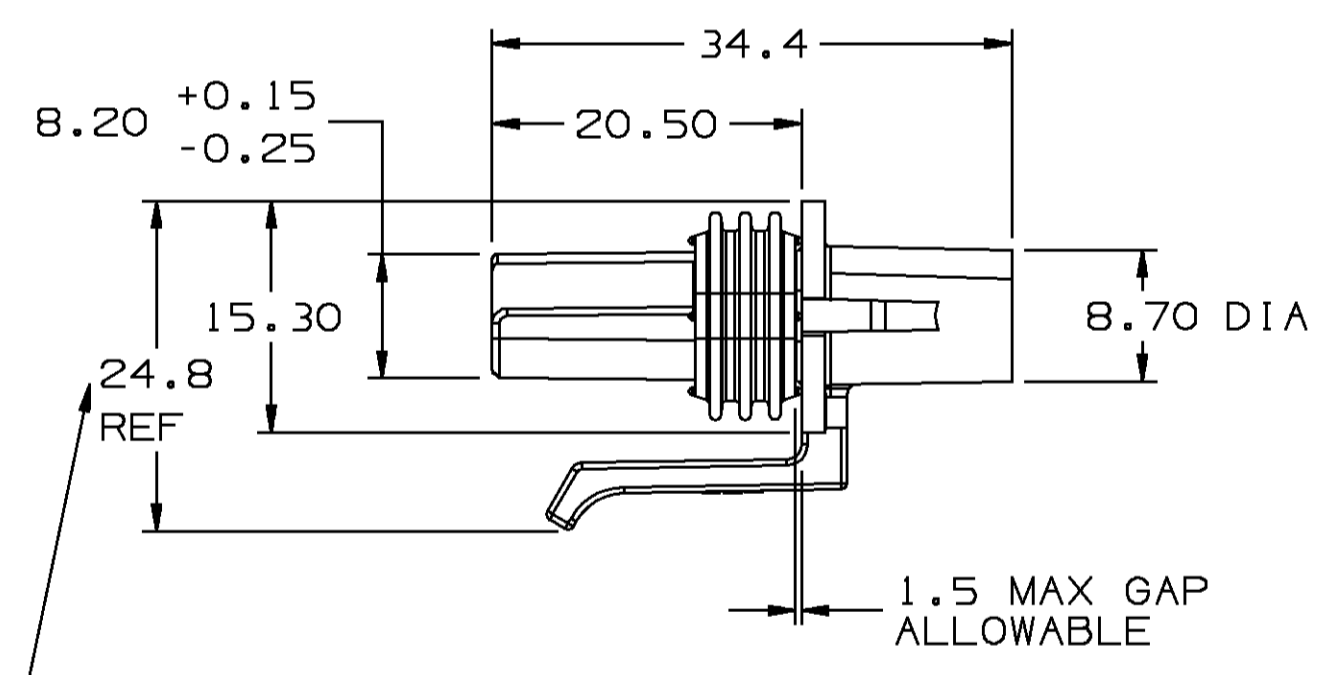
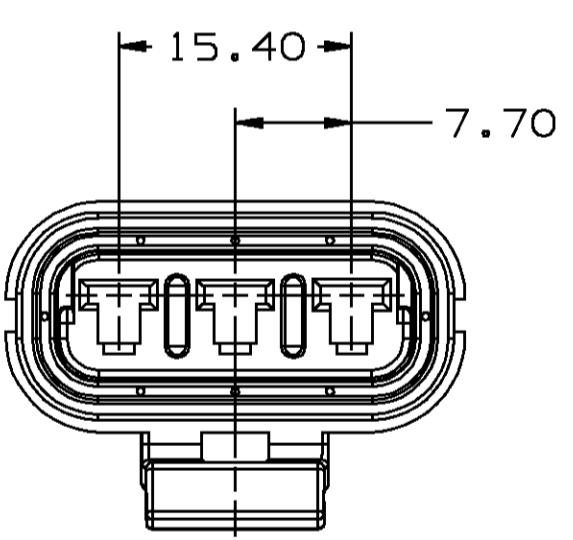
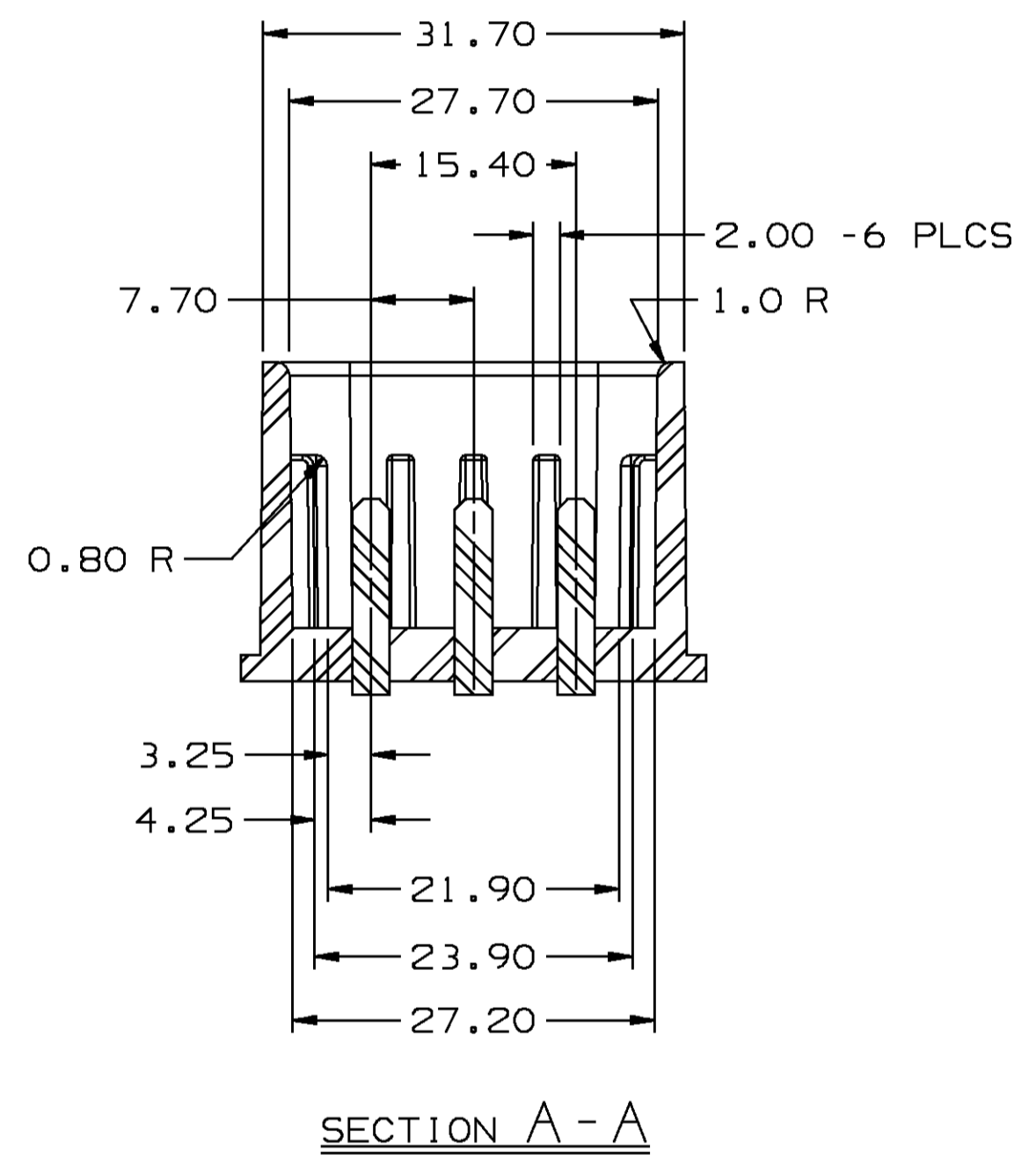
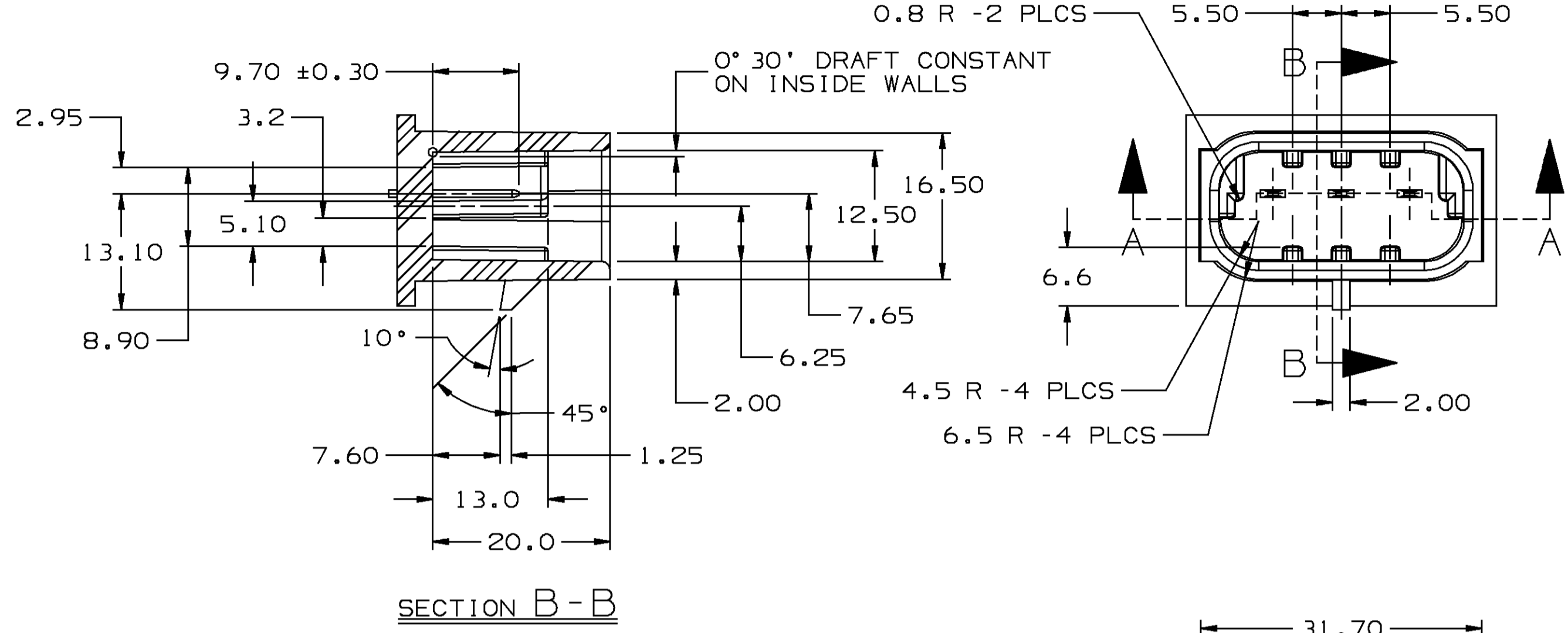
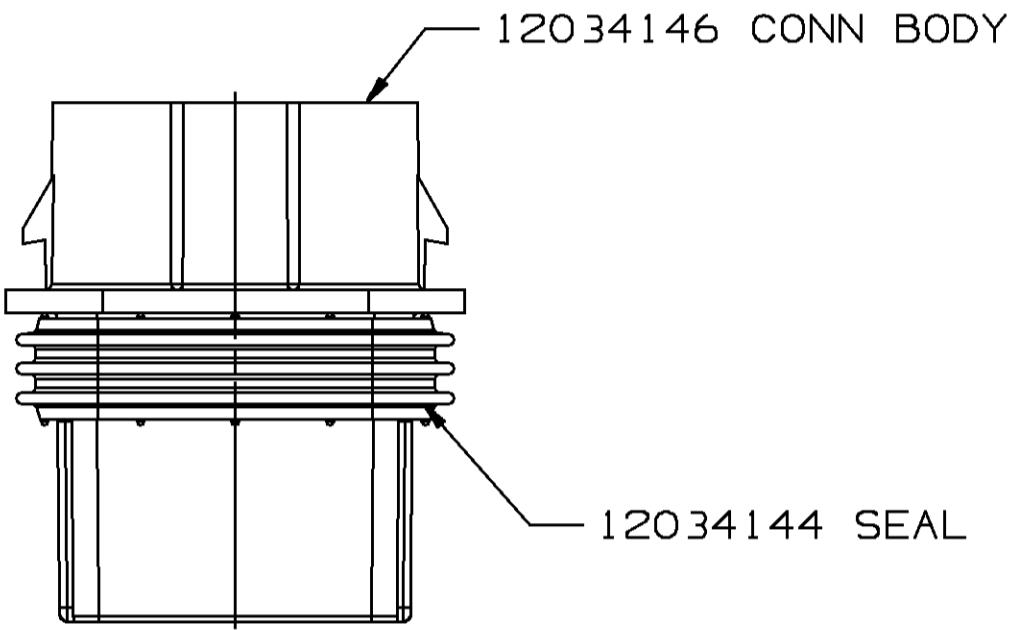
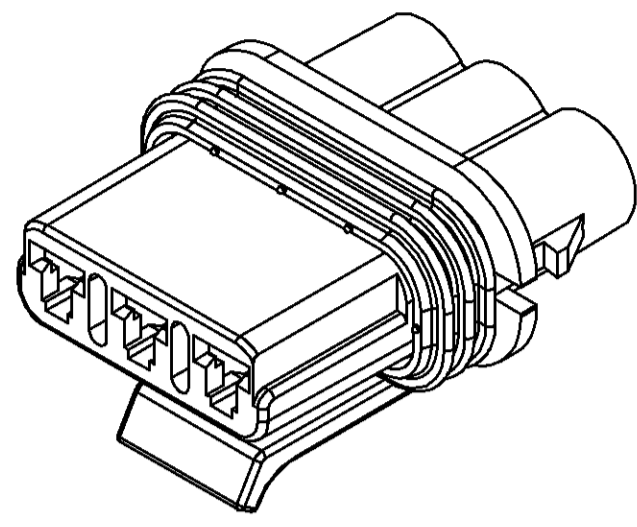

THIS DIMENSION CAN INCREASE TO 30.0 MAX, WHEN BEING ASSEMBLED TO MATING PART

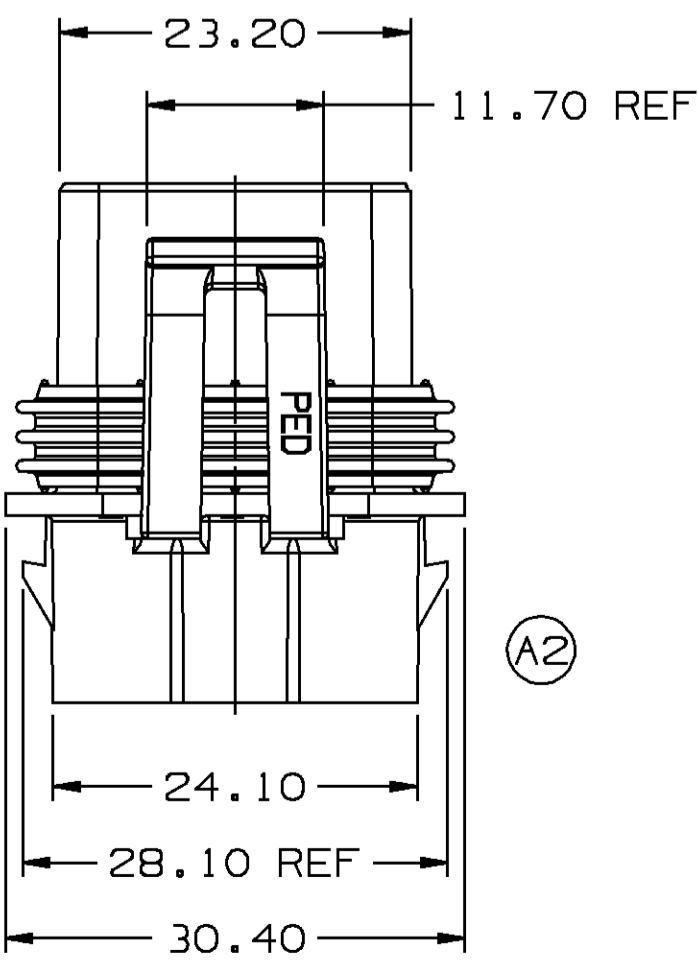

- NOTES:
- CAVITIES TO ACCEPT 12077411 TERMINAL OR EQUIVALENT
  - USE CABLE SEAL 12015323 OR EQUIVALENT
  - CONNECTOR TO ACCEPT 12034145 SECONDARY LOCK (TPA) OR EQUIVALENT.
  - THIS CONNECTOR TO MATE WITH AC6456 SENSOR
  - WHEN PARTS ARE SHIPPED THEY MUST BE PACKED IN PLASTIC BAGS OR SHIPPING CONTAINERS MUST BE LINED WITH PLASTIC LINERS. BAGS OR LINERS MUST BE SEALED TO AVOID ENTRY OF FOREIGN MATTER.
  - SEALING CODE 3.
- DESIGN WILL PASS SALT FOG AND IMMERSION TEST AFTER CONDITIONING AS SPECIFIED IN ESA-644 (WEATHER-PACK), ESA-710 (METRI-PACK), ESA-650 (UNDERHOOD MICRO-PACK), C-4006 (WORLD CONNECTOR), ETC. - WHEN MATED TO MATING PART OR EQUIVALENT.
- DIMENSIONS ARE TO FACE OF VIEW SHOWN AND AUTOMATICALLY ROUNDED BY COMPUTER FOR INSPECTION. (SEE MATH MODEL FOR PRECISE DIMENSION) FOR ALL OTHER DIMENSIONS NOT SHOWN BUT REQUIRED FOR TOOL BUILD, SEE MATH MODEL FOR PRECISE TOOL PATH DATA.
  - DIMENSIONS MARKED "REF" ARE FOR REFERENCE ONLY AND NO TOLERANCE LIMITS ARE ESTABLISHED.

PART NO  
1203 4147

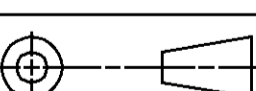
DRAWING TYPE <b>DETAIL</b>		OTHER DRAWINGS AVAILABLE	
<b>UtiGraphics II</b>		<b>METRIC</b>	
THIRD ANGLE PROJECTION		DIMENSIONS ARE IN MILLIMETERS UNLESS OTHERWISE SPECIFIED	
		TOLERANCE UNLESS OTHERWISE SPECIFIED DECIMAL: ANGULAR: ± 2° ONE PLACE ± 0.3 TWO PLACE ± 0.15	
CODE NO	QC	DES	
6900	-C-5110		
DWG DATE	29JN82	DR	DAVE BOCK 20AUB2
SCALE	2:1	CK	R.W GLEASON 07SE82
REFERENCE NO		APPR	J.C GRIFFIN 08SE82
MATERIAL SPEC		VOL CM <sup>3</sup>	
SEE DRAWING			
NAME ASM CONN 3F M/P 280 SLD			
PART NUMBER		SIZE	
1203 4147		A1	

DELPHI PACKARD ELECTRIC SYSTEMS  
WARREN, OHIO 44466