

SYMBOL DEFINITION		MISSING SYMBOLS	
A DIMENSION WITHOUT AN INSPECTION REPORT SYMBOL DOES NOT REQUIRE INSPECTION. IT MAY BE CONTROLLED ON THE INDIVIDUAL COMPONENT DRAWING.	TOTAL NO OF INSPECTIONS REQUIRED	NO MISSING SYMBOL NUMBER	
	29		
	LAST NO. USED	14	

DWG STATUS				REVISION HISTORY				AUTH	DR	APVD	APVD
DATE	STG	REV	W/P	CHG	ZONE						
13JUN02	R	A6	-	-		CREATED PD, ADDED OPTIONAL LOGO & MATERIAL RECYCLING CODE NOTES AND REVISED MATERIAL SPEC	226742	EOV	EOV	ET	ET
15JAO3	R	Q2	-	-		MAT'L SPEC WAS M3596002 PA6 BLK	235588	RVP	RVP	RC	RC

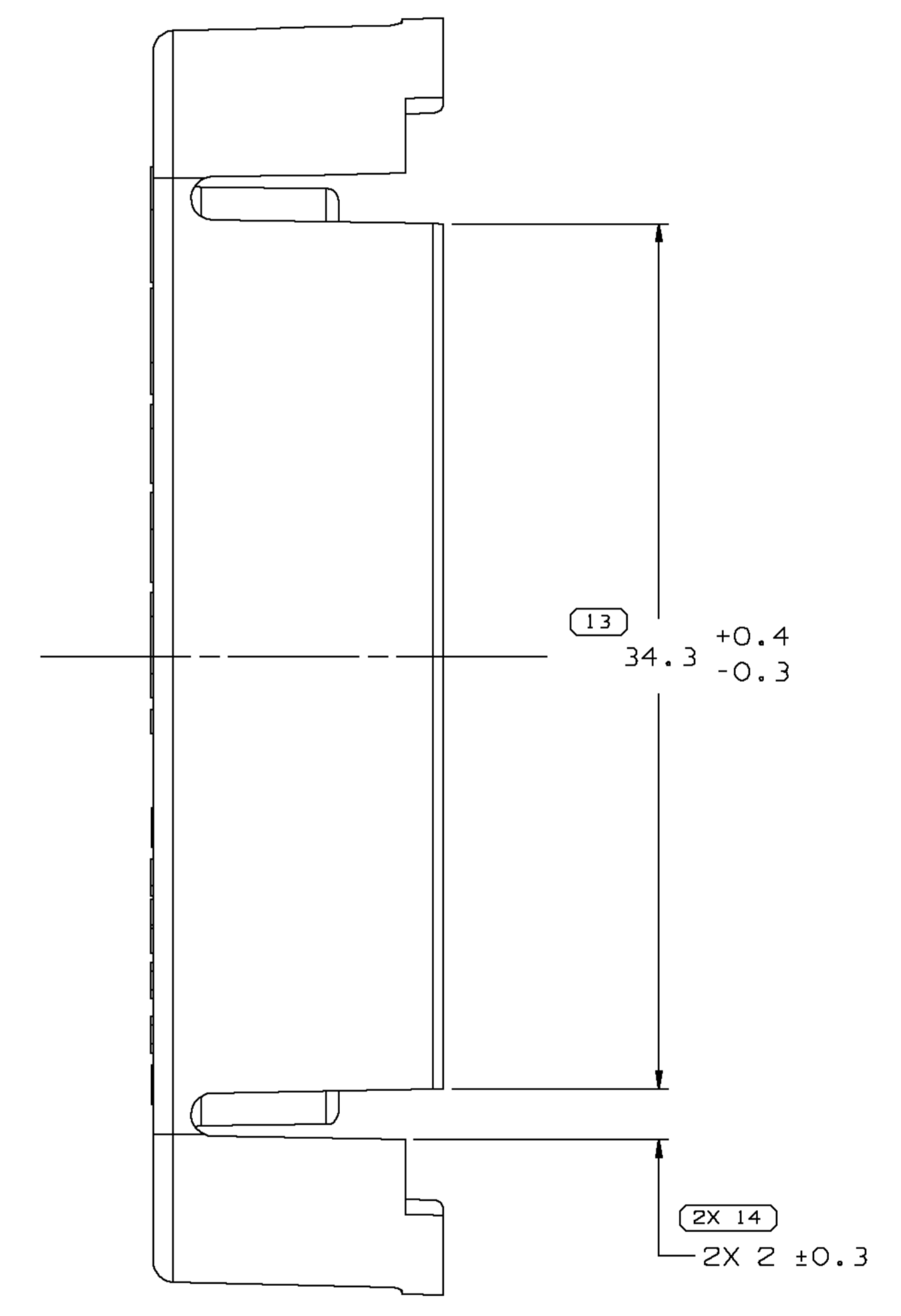
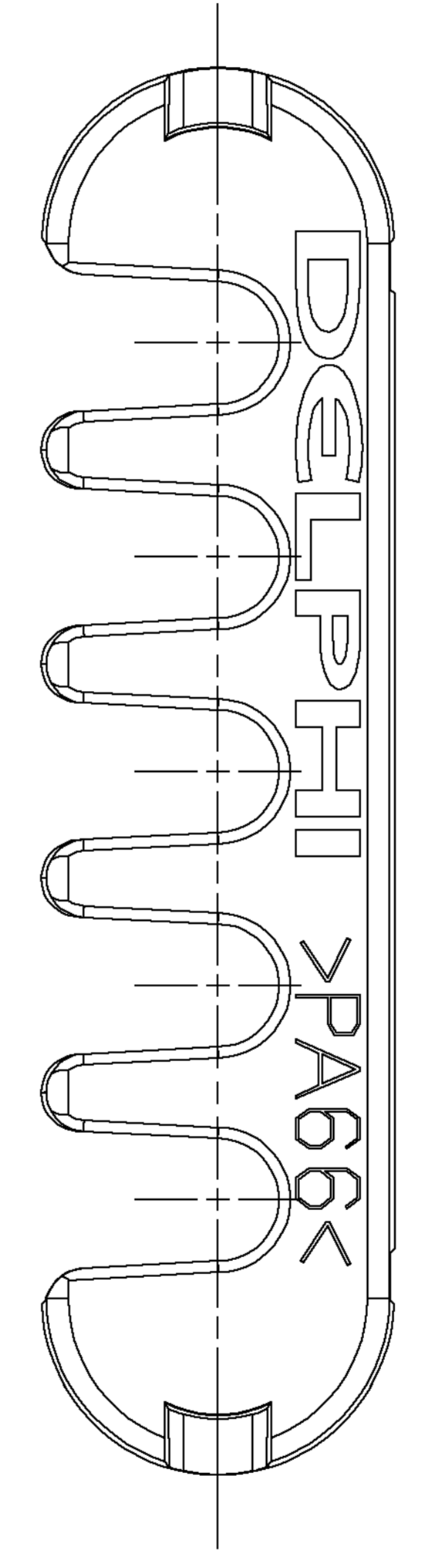
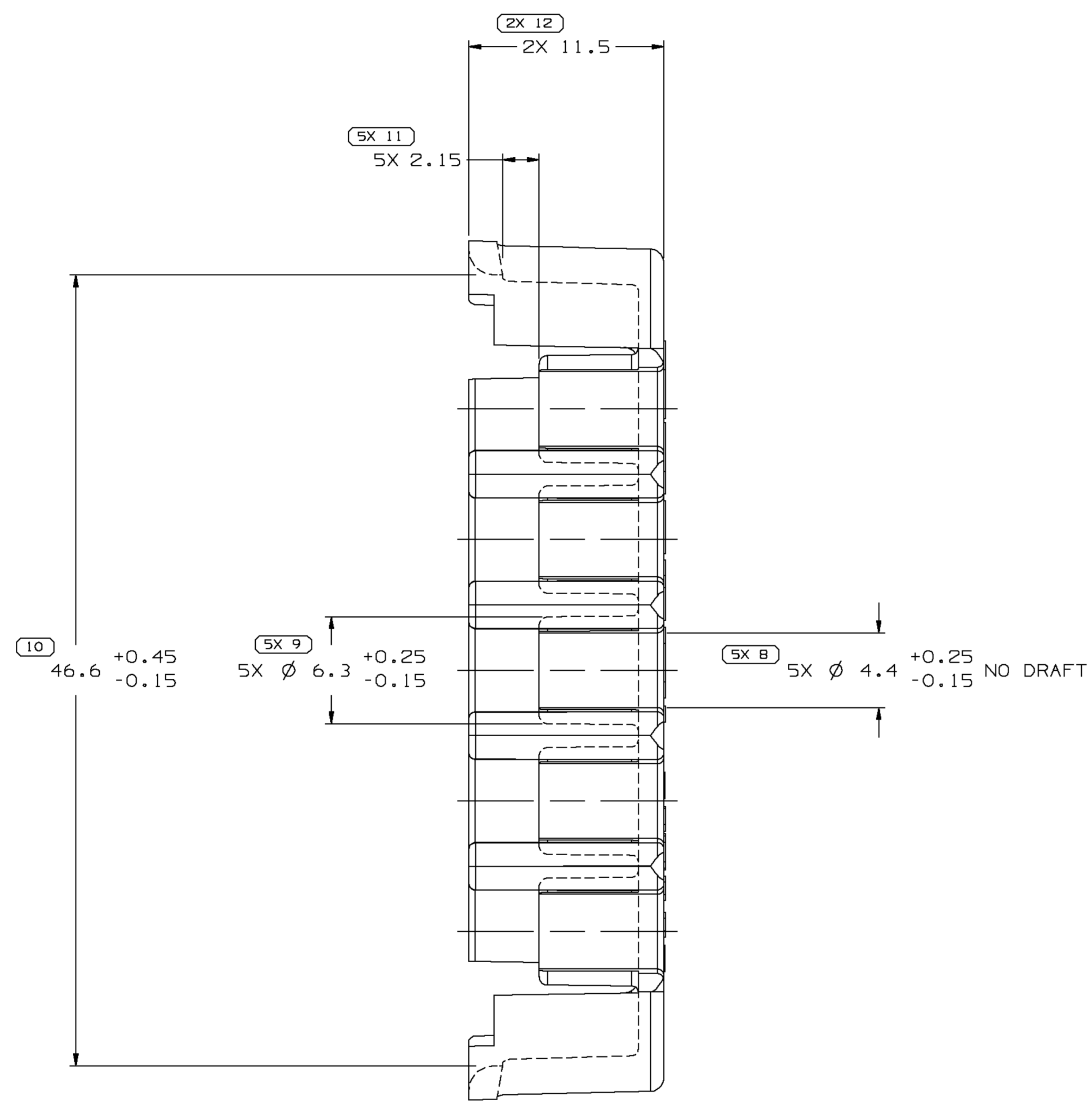
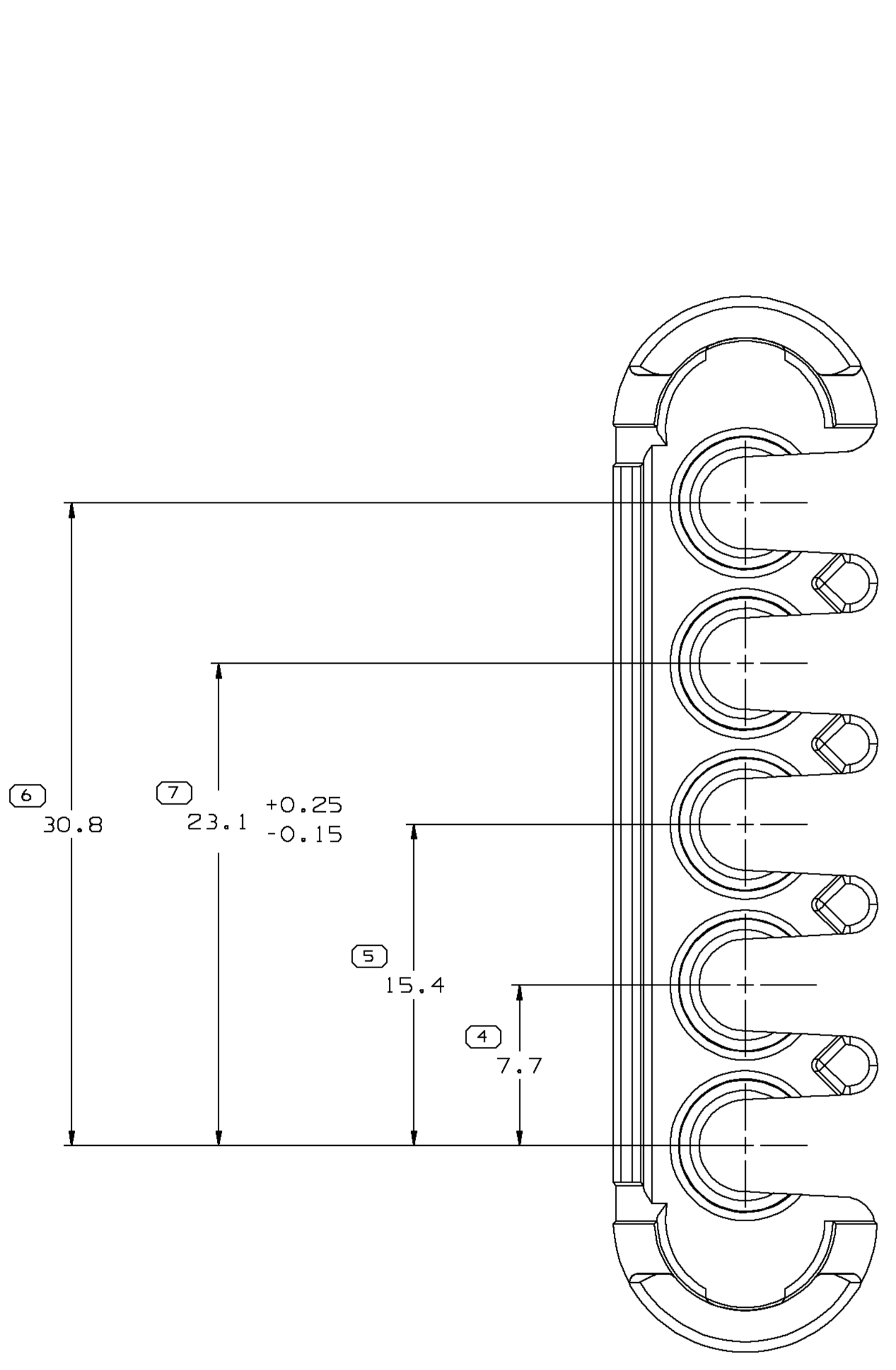
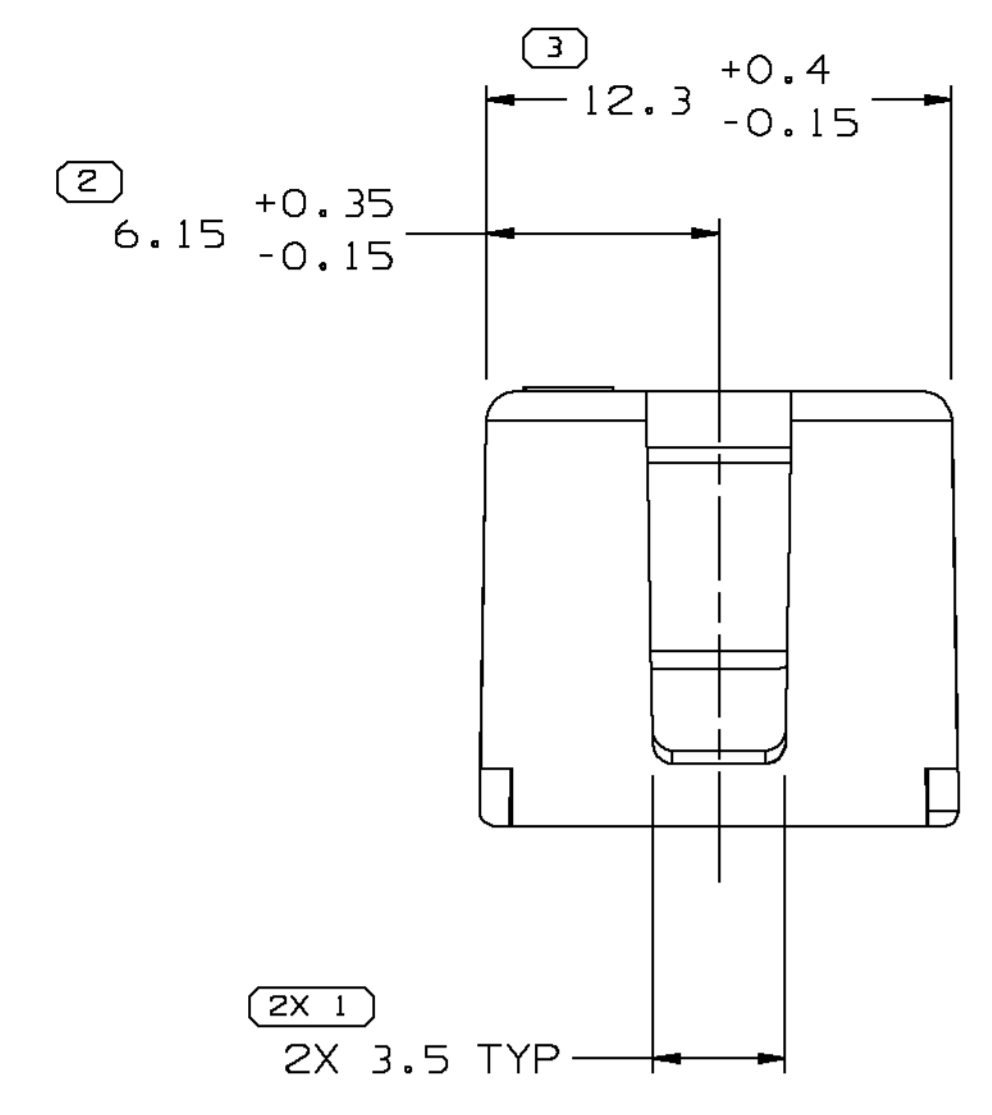

NOTES

- UNLESS OTHERWISE SPECIFIED AND/OR INDICATED: DIMENSIONS ARE TO FACE OF VIEW SHOWN AND AUTOMATICALLY ROUNDED BY COMPUTER FOR INSPECTION (SEE MATH MODEL FOR PRECISE DIMENSIONS). FOR ALL OTHER DIMENSIONS NOT SHOWN BUT REQUIRED FOR TOOL BUILD, SEE MATH MODEL FOR PRECISE TOOL PATH DATA.
- MATERIAL RECYCLING CODE >PA66< PER SAE J1344. (2.31X(0.1) RAISED CHARACTERS AS SHOWN TO BE LOCATED ON ANY EXTERIOR SURFACE. OPTIONAL CONSTRUCTION TO BE NO MATERIAL RECYCLING CODE.
- THIS PART IS NOT CONTROLLED FOR AUTOMATIC FEEDING.
- MATING COMPONENTS OR EQUIVALENT: CONNECTOR 12084672
- (2.31X(0.1) RAISED DELPHI CORPORATE BRAND TO BE LOCATED ON ANY EXTERIOR SURFACE, PREFERABLY VISIBLE AT FINAL ASSEMBLY. OPTIONAL CONSTRUCTION TO BE "PED" OR NO LOGO.
- MAXIMUM CABLE O.D. THAT WILL FIT THIS PART IS 4.2.

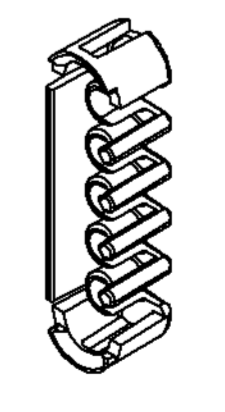

R 0.2 MAX SHARP CORNER TOLERANCE	R 0.1 MAX	DIMENSIONAL RANGE (MM)		CHART ET
		FROM	TO	
		0	20	30
		20	30	70
		30	70	100
		70	100	150
		100	150	200
		150	200	250
		200	250	300
		250	300	400
		TOLERANCE UNLESS OTHERWISE SPECIFIED		
		±0.15	±0.2	±0.3
		±0.4	±0.5	±0.6
		±0.8	±1	±1.2
		ANGULAR TOLERANCE ±2°		

DWO TYPE		PART DRAWING	
STYLE	2,065	DISTR CODE	D
VOLUME (CPI)	6901		
UNLESS OTHERWISE SPECIFIED			
THIS DOCUMENT IS IN ACCORDANCE WITH ASME Y14.5M-1994 AS AMENDED BY THE 2003 DIMENSIONING AND TOLERANCING ADDENDUM - 1997. ALL GEOMETRIC TOLERANCES AND RELATED DATUMS APPLY TO ALL DIMENSIONS UNLESS OTHERWISE SPECIFIED. DIMENSIONS ARE TO FACE UNLESS OTHERWISE SPECIFIED. DIMENSIONS ARE IN MILLIMETERS.			
REFERENCE		THIRD ANGLE PROJECTION	
		DO NOT SCALE	
		USE MATH DATA	

**DELPHI**  
DELPHI PACKARD ELECTRIC SYSTEMS  
WARREN, OH

DR	DATE
APVD1 E. VAZQUEZ	13JUN02
APVD2 E. VAZQUEZ	13JUN02
APVD3 E. TRACEY	14JUN02
APVD4	
APVD5	

MATERIAL: M3592001 PA66 HS 1M BLK

DRAWING NAME: LOCK TERM LK TPA 4 BLK

DRAWING NUMBER: 12084673

SIZE: A0 SCALE: 5:1 FRAME NO: 1 SHEET NO: 1 OF 1 STG: REV: W/P: R: Q2