

**MATERIAL SPECIFICATIONS**

**RECOMMENDED**  
 BASE METAL P-1546-(CA-210), BRASS-EXTRA SPRING TEMPER  
 PLATING - 0.004±0.001 MM THICK TIN

**MINIMUMS**  
 ELECTRICAL CONDUCTIVITY - ≥20% IACS AT 20°C. USE OF A MATERIAL WITH CONDUCTIVITY < 20% IACS MUST BE APPROVED BY PACKARD ELECTRIC MATERIALS ENGINEERING.  
 TENSILE STRENGTH - 430 MPa

**MATING BLADE INFORMATION**  
 SCALE 8:1

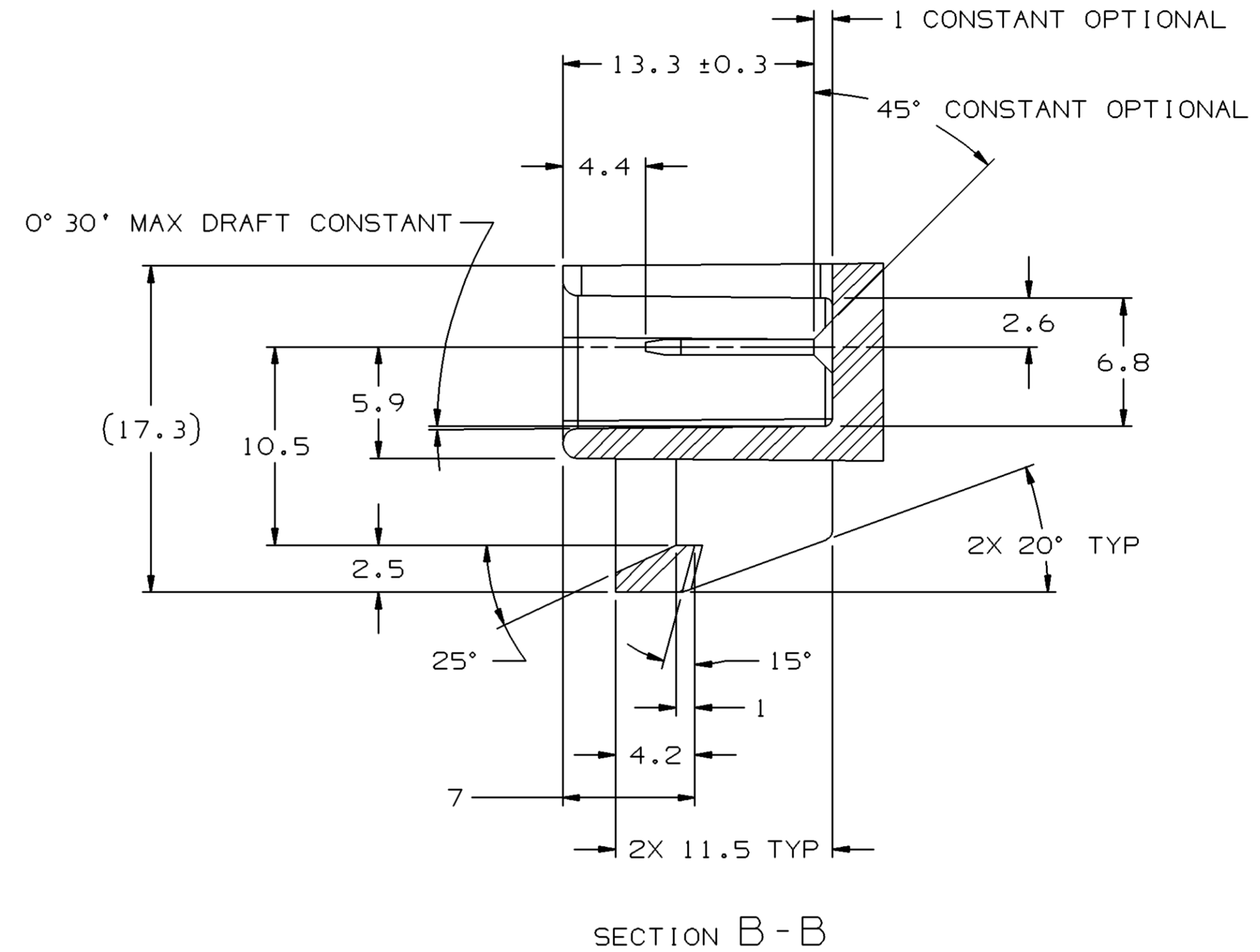
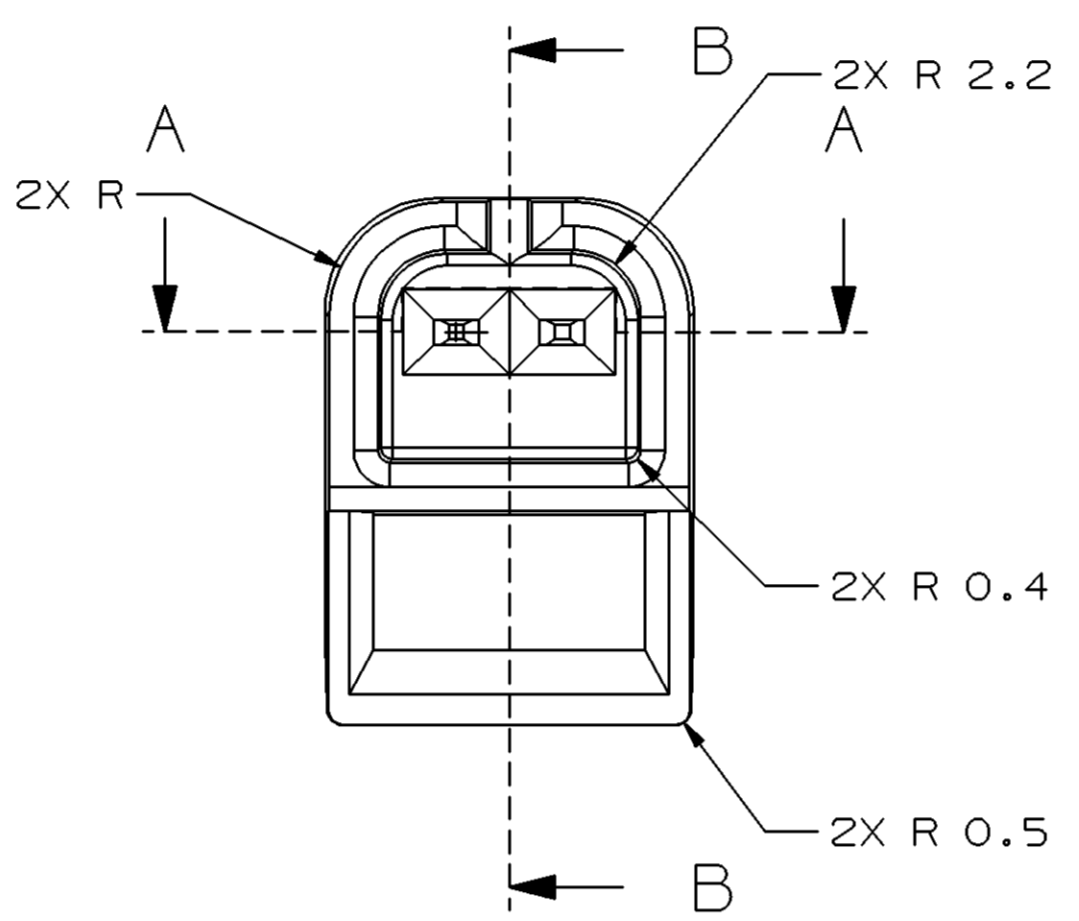
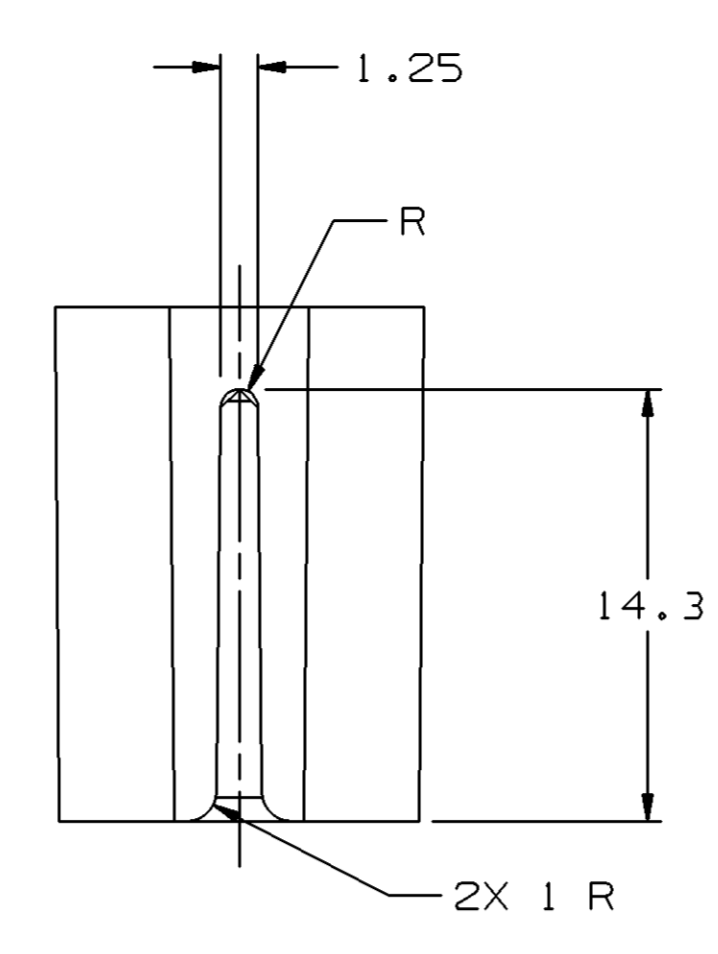
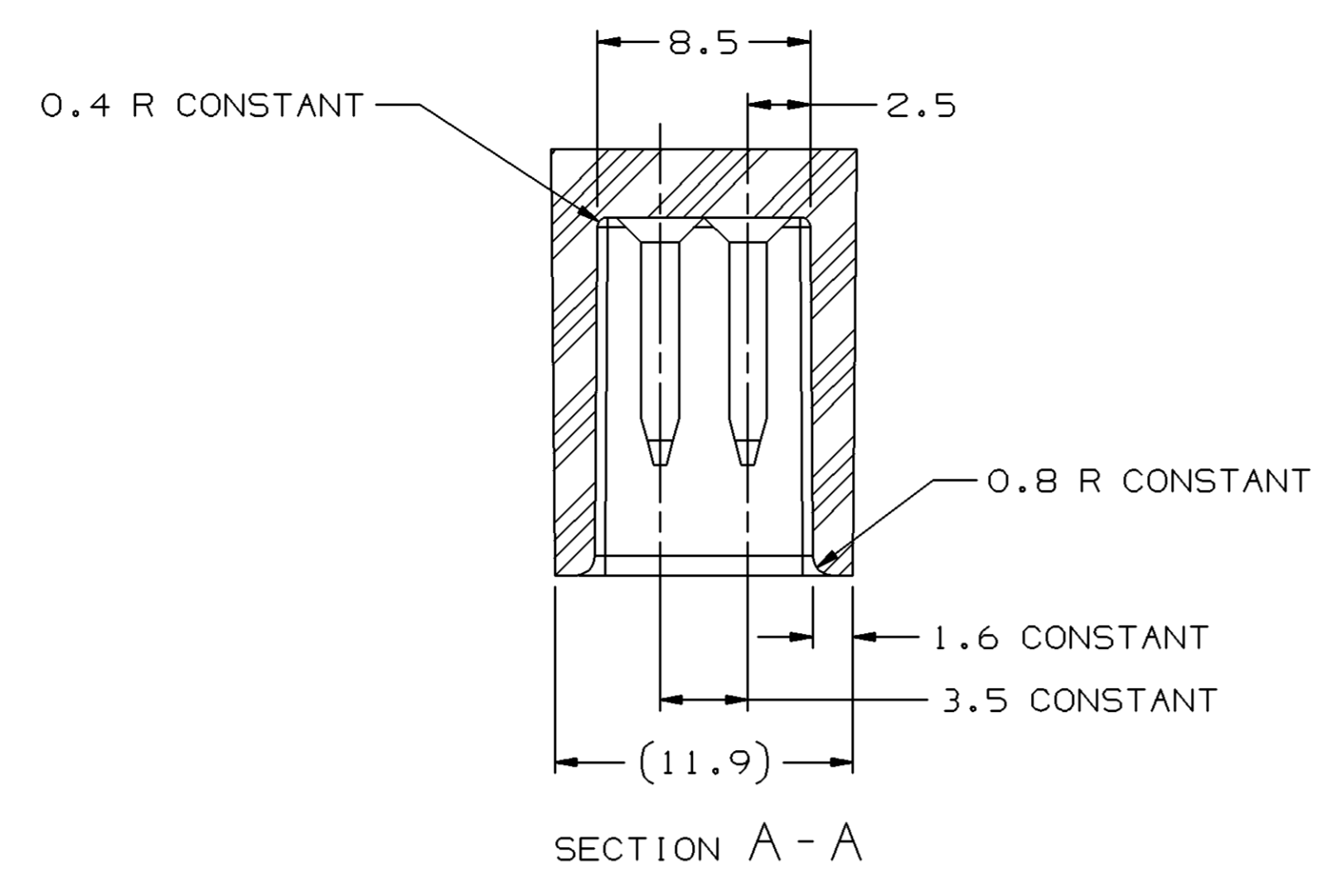
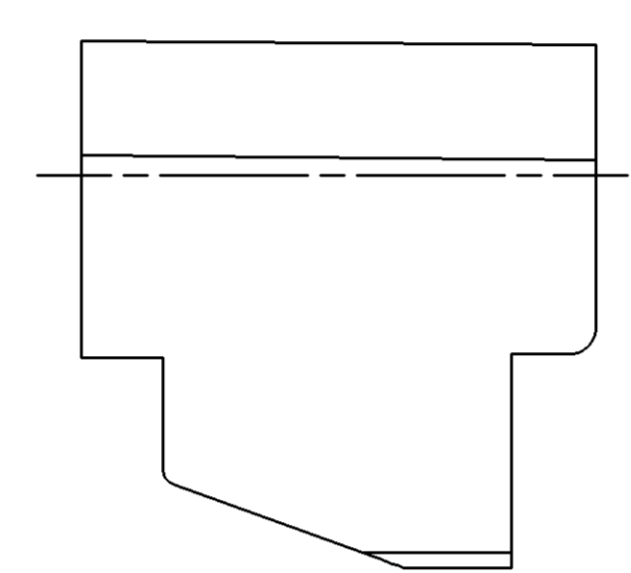

**MATING CONNECTOR INFORMATION**  
 SCALE 4:1

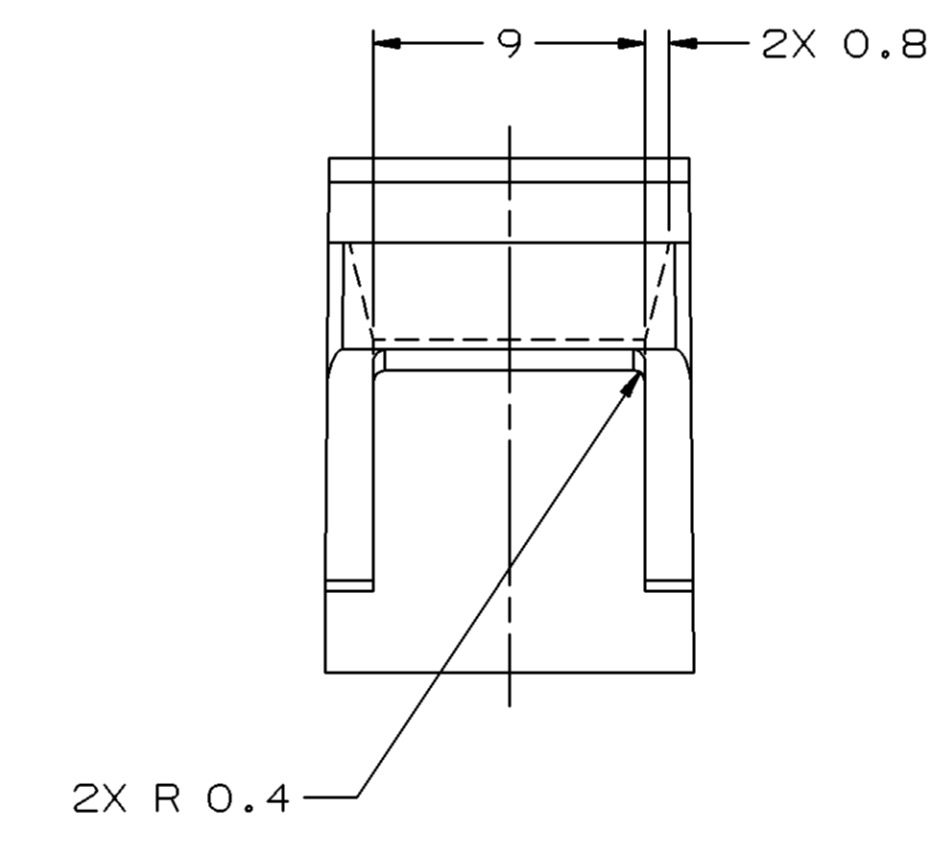

**NOTES**

- UNLESS OTHERWISE SPECIFIED AND/OR INDICATED: DIMENSIONS ARE TO FACE OF VIEW SHOWN AND AUTOMATICALLY ROUNDED BY COMPUTER FOR INSPECTION (SEE MATH MODEL FOR PRECISE DIMENSIONS). FOR ALL OTHER DIMENSIONS NOT SHOWN BUT REQUIRED FOR TOOL BUILD, SEE MATH MODEL FOR PRECISE TOOL PATH DATA. ALL RADII 0.5. DRAFT 15 0°30' MAX ON ALL OUTSIDE SURFACES.
- MATING COMPONENTS OR EQUIVALENT: CONNECTOR 12052832
- TERMINALS MUST WITHSTAND A MINIMUM PUSHOUT FORCE OF 89N (20LBS).
- RECOMMENDED BODY MATERIAL: POLYESTER OR EQUIVALENT THERMOPLASTIC.

**NOTES**

- UNLESS OTHERWISE SPECIFIED AND/OR INDICATED: DIMENSIONS ARE TO FACE OF VIEW SHOWN AND AUTOMATICALLY ROUNDED BY COMPUTER FOR INSPECTION (SEE MATH MODEL FOR PRECISE DIMENSIONS). FOR ALL OTHER DIMENSIONS NOT SHOWN BUT REQUIRED FOR TOOL BUILD, SEE MATH MODEL FOR PRECISE TOOL PATH DATA.
- MATERIAL RECYCLING CODE PER ISO 11469. (2,31X10.1) RAISED CHARACTERS AS SHOWN TO BE LOCATED ON ANY EXTERIOR SURFACE. OPTIONAL CONSTRUCTION TO BE NO MATERIAL RECYCLING CODE.
- REFERENCE MATING COMPONENTS OR EQUIVALENT: CONNECTOR 12052833
- THIS PART ACCEPTS THE FOLLOWING COMPONENTS OR EQUIVALENT: TERMINAL 12047893 MAX INSULATION CRIMP MUST BE LESS THAN 2.65 HIGH AND 2.7 WIDE. SECONDARY TERMINAL LOCK 15324070 CONNECTOR POSITION ASSURANCE LOCK 12052834
- (2.3)X(0.1) RAISED DELPHI CORPORATE BRAND TO BE LOCATED ON ANY EXTERIOR SURFACE, PREFERABLY VISIBLE AT FINAL ASSEMBLY. OPTIONAL CONSTRUCTION TO BE "PED" OR NO LOGO.
- THIS CONNECTOR WILL PASS THROUGH A Ø19 MIN HOLE.

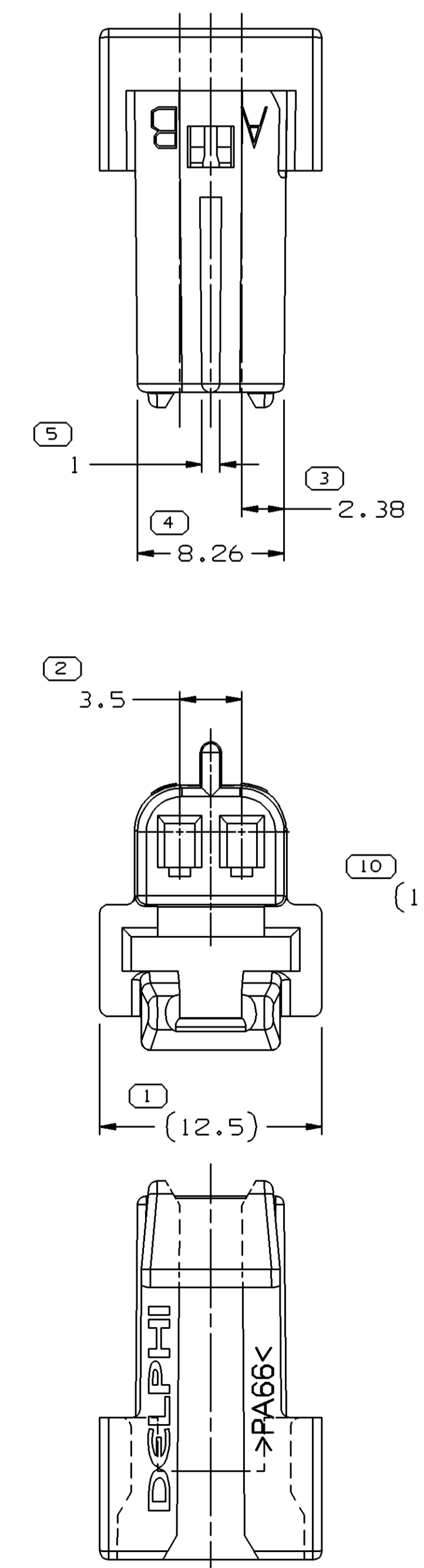

PART NO	REV	N/P	STATUS	MATERIAL SPECIFICATION AND COLOR	VOL CM <sup>3</sup>
15434358	01	AA		M3592008 PA66 HS IM BLU	1.103
15433787	01	AA		M3592012 PA66 HS IM GRA LT	1.103
12186847	02	-		M3592024 PA66 HS IM CRM	1.103
12052832	D3	-		M3592001 PA66 HS IM BLK	1.103

SYMBOL DEFINITION	TOTAL NO OF INSPECTIONS REQUIRED	MISSING SYMBOL NUMBER
A DIMENSION WITHOUT AN INSPECTION REPORT SYMBOL DOES NOT REQUIRE INSPECTION. IT MAY BE CONTROLLED ON THE INDIVIDUAL COMPONENT DRAWING.	15	
	LAST NO. USED	15

DATE	STG	REV	N/P	CHG	ZONE	REVISION HISTORY	AUTH	DR	APVD	1	2
15MR02	R	01	-	-		CLEARED REV COLUMN: ALL PARTS - ADDED LOGO NOTE & RECYCLING CODE NOTE AND REVISED MAT'L SPEC: 15433787 - RELEASED	222661	RH	RH	GM	GM
02MY02	R	02	-	-		15434358 - RELEASED	224278	RH	RH	GM	GM
04SE02	R	03	-	-		ALL PARTS - SECONDARY TERMINAL LOCK NOTE WAS 12047664	230019	RVP	RVP	GM	GM
16AU05	R	04	-	-		12186847 - MATERIAL SPEC WAS M3592002 PA66 HS IM NAT	271092	EES	EES	ET	ET

DIMENSIONAL RANGE (MM)	CHART ET
FROM > 0	> 20
TO 20	30
	70
	100
	150
	200
	250
	300
	400
	10,15
	±0.2
	±0.3
	±0.4
	±0.5
	±0.6
	±0.8
	±1
	±1.2
	ANGULAR TOLERANCE 12'

**DELPHI**  
 DELPHI PACKARD ELECTRIC SYSTEMS  
 WARREN, OH

DR	DATE
APVD1 MIKE ROMERO	10E96
APVD2 RICARDO PINA	11E96
APVD3 S. HEFFERNAN	21AP97
APVD4	
APVD5	

UNLESS OTHERWISE SPECIFIED  
 THIS DOCUMENT IS IN ACCORDANCE WITH ASME Y14.5M-1994  
 AS MODIFIED BY THE 2003 DIMENSIONING AND TOLERANCING ADDENDUM - 1997. ALL GEOMETRIC TOLERANCES AND RELATED DATUMS APPLY TO ALL FEATURES UNLESS OTHERWISE SPECIFIED.  
 MDCI DOES NOT APPLY WHEN RELATIONSHIP BETWEEN FEATURES IS ESTABLISHED BY ORIENTATION OR LOCATION TOLERANCES. SEPARATE POSITION DATUMS MAY BE OBTAINED SEPARATELY, REGARDLESS OF DATUM REFERENCE.  
 ALL DIMENSIONS ARE IN MILLIMETERS.

DRAWING NAME: TAXI CONN 2 F M/P 150  
 DRAWING NUMBER: 12186848

SIZE: A0  
 SCALE: 4:1  
 FRAME NO: 1 OF 1  
 SHEET NO: 1 OF 1  
 STG: R  
 REV: 04