

THIS DRAWING AND DESIGN HEREON CONSTITUTE A PROPRIETARY SIGN OF PACKARD ELECTRIC DIVISION AND IS NOT TO BE DUPLICATED OR REPRODUCED WITHOUT AUTHORITY OF PACKARD ELECTRIC DIVISION.
DO NOT SCALE

MATING TERMINAL INFORMATION

PART NO. 1208 9588

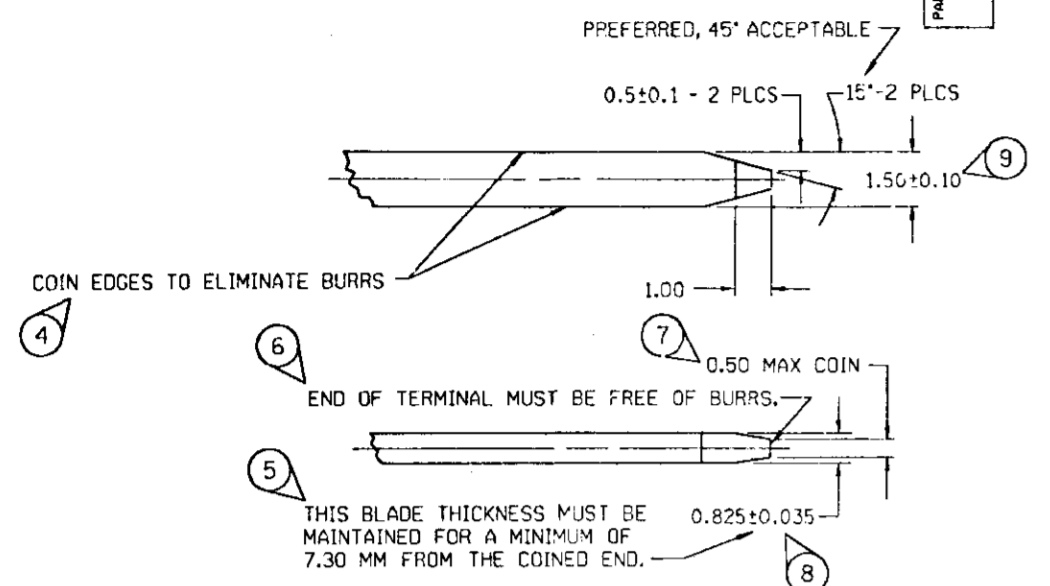

NOTE — TERMINALS ARE IDENTICAL.

MATERIAL — RECOMMENDED MATERIAL IS P-1545 (CDA 210) - EXTRA SPRING TEMPER - TIN PLATED BRASS
PLATING THICKNESS: 0.0026 - 0.0076 MM
TENSILE STRENGTH: 430 - 480 MPa
(MATERIAL SHOULD HAVE AN ELECTRICAL CONDUCTIVITY $\geq 20\%$ IACS AT 68°F. USE OF MATERIAL WITH CONDUCTIVITY $< 20\%$ IACS SHOULD BE APPROVED BY PACKARD ELECTRIC.)

MATING CONNECTOR

PART NO. 1208 9588

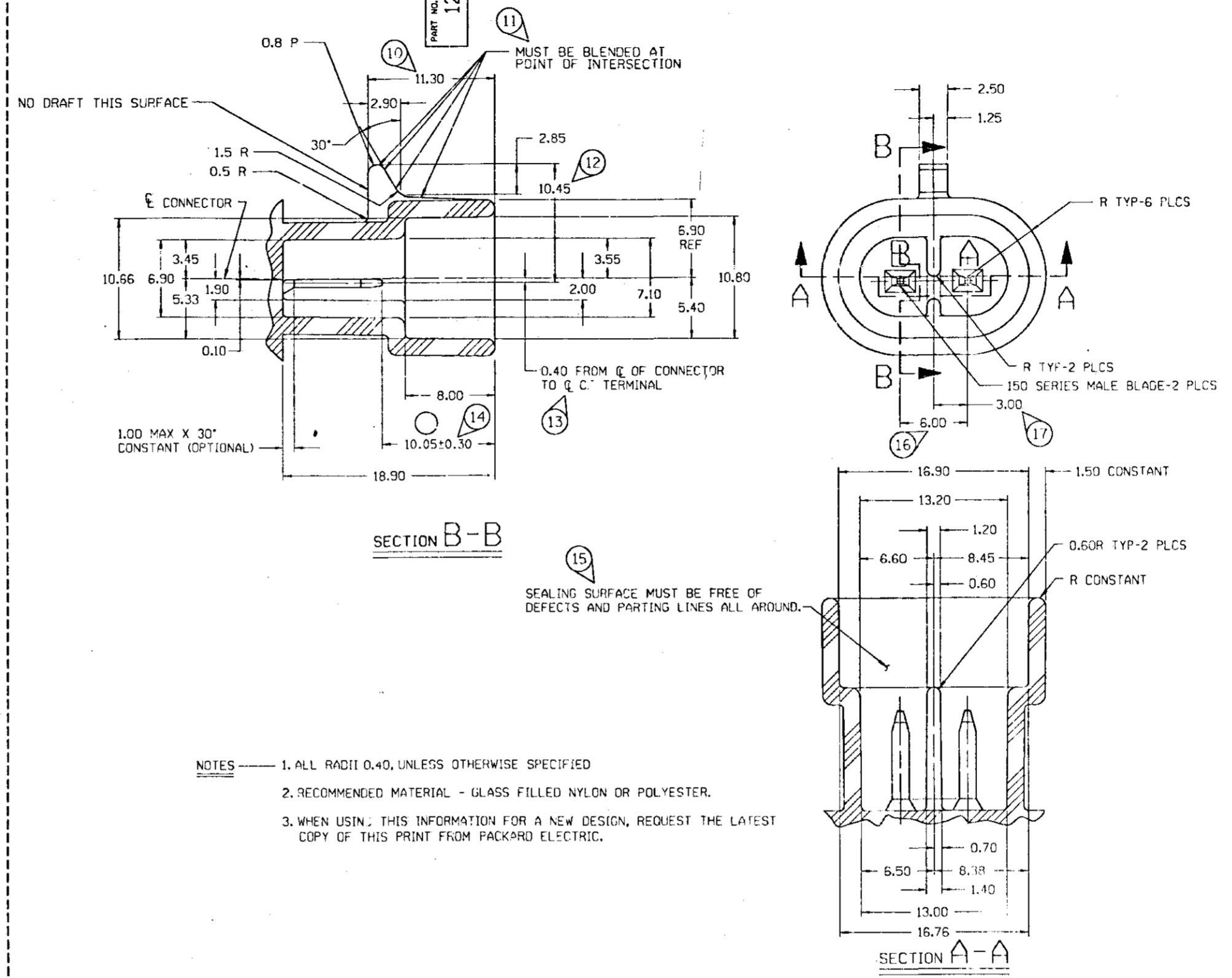

- NOTES** — 1. ALL RADII 0.40, UNLESS OTHERWISE SPECIFIED
2. RECOMMENDED MATERIAL - GLASS FILLED NYLON OR POLYESTER.
3. WHEN USING THIS INFORMATION FOR A NEW DESIGN, REQUEST THE LATEST COPY OF THIS PRINT FROM PACKARD ELECTRIC.

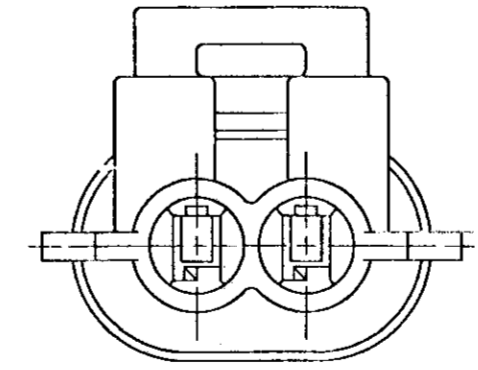
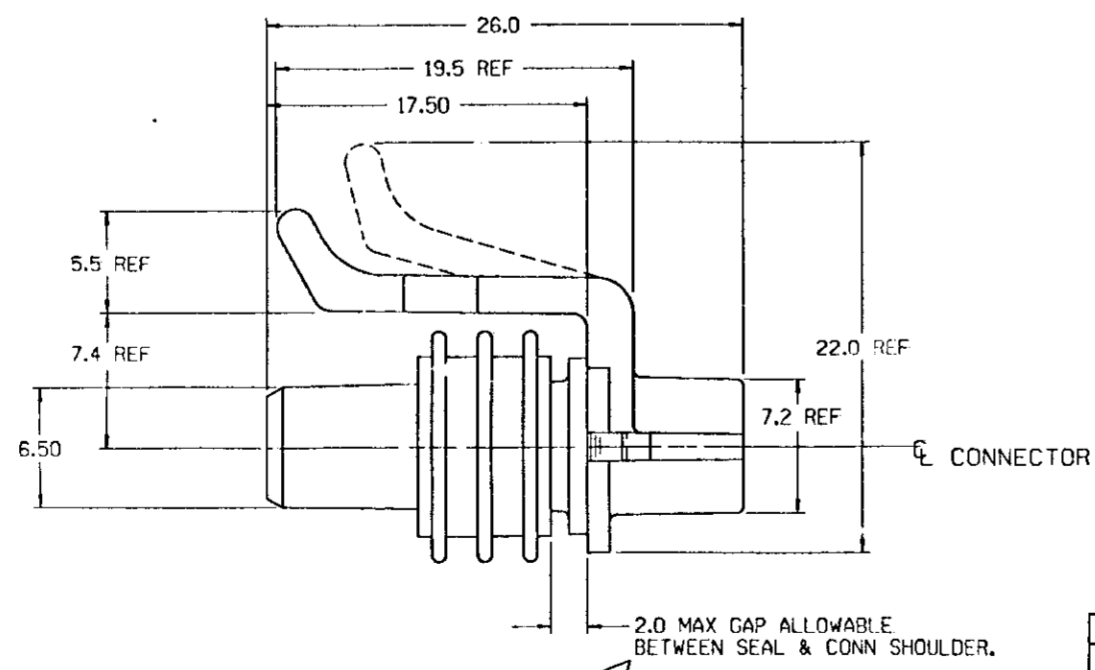
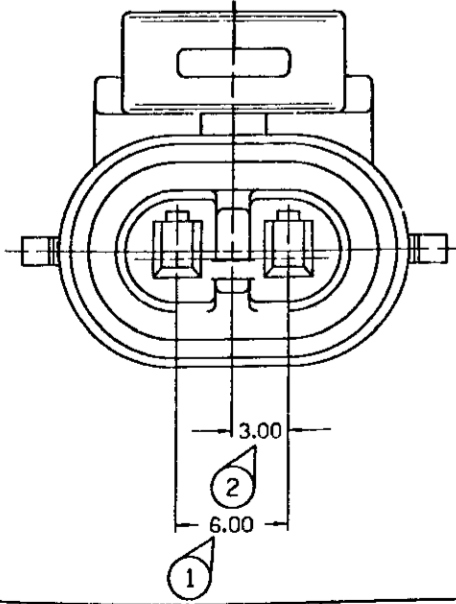
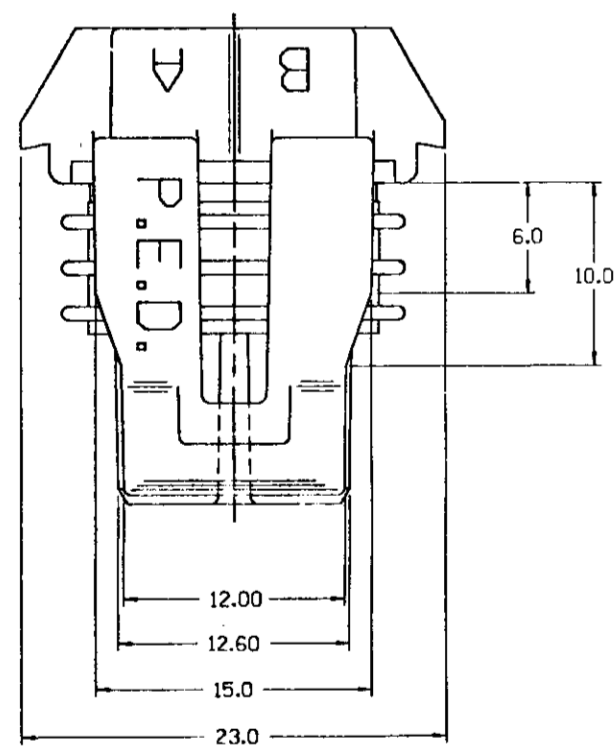

- NOTES** — 1. CAVITIES TO ACCEPT 12045074 TERMINAL OR EQUIVALENT.
2. THIS CONNECTOR TO ACCEPT CABLE SEAL 12048086 OR EQUIVALENT.
3. THIS CONNECTOR TO ACCEPT SECONDARY LOCK 12052634 OR EQUIVALENT.
4. THIS CONNECTOR IS TO MATE WITH DR AIR SWITCH SOLENOID OR EQUIVALENT.
5. MAXIMUM CABLE DIAMETER - 2.80 MM
6. WHEN PARTS ARE SHIPPED, THEY MUST BE PACKED IN PLASTIC BAGS OR SHIPPING CONTAINERS MUST BE LINED WITH PLASTIC LINERS. BAGS OR LINERS MUST BE SEALED TO AVOID ENTRY OF FOREIGN MATTER.
7. SEALING CODE 3.
8. *C* DENOTES DIMENSIONS AND CHARACTERISTICS THAT ARE IMPORTANT TO THE FUNCTION AND/OR PROCESSING OF THE PART. IT DOES NOT NECESSARILY INDICATE AN S.P.C. DIMENSION. THIS DRAWING HAS 17 SNOWCONES.

12052642	C	2	NONE	12052636	12103067	SEE NOTE #4	LT GRN
PART NO.	REV	STATUS	NUMBER OF CAVITIES	CAVITIES BLOCKED	CONNECTOR BODY	CONNECTOR SEAL	MATING CONNECTOR COLOR

DATE	SYM	REVISION RECORD	AUTHORITY	CHK	CK
11AP91		12052642 - WAS SEPARATE "D" SIZE			
		DWG & REMOVED "ASM DIMENSIONING"			
		POINT - REV LEVEL REMAINS AT "C"	141309	JC	JC
06JL92		ALL PARTS - REVISED MATING CONN.			
		10.05±0.30 WAS 9.3 - NO REV			
		UPDATE REQ'D	150014	TS	TS

FILE: STEELE T
SPEC: 2F06115,27712089588A.D031
Tue Jul 07 02:47:07 1992

THIRD ANGLE PROJECTION

METRIC
DIMENSIONS ARE IN MILLIMETERS UNLESS OTHERWISE SPECIFIED.

CODE NO. 6900
TOLERANCE UNLESS OTHERWISE SPECIFIED
DECIMALS ANGULAR ±2°
ONE PLACE ±0.3
TWO PLACE ±0.15

DWG. DATE 14MR89 SCALE 4:1
DR. J. COLDSNOW 11AP91

EST. NO. DR. J. COLDSNOW
REFERENCE NO. APPR. R. LANDRIES DATE 16AP91
APPR. DATE

MATERIAL SPEC. SEE CHART

NAME ASM CONN F/M/P 150

PART NO. 1208 9588 SIZE D
SHEET 3 1 PACKARD ELECTRIC