



# Inductors

## RF chokes, BC series

**Series/Type:** B78108S, B78148S

**Date:** June 2012

© EPCOS AG 2015. Reproduction, publication and dissemination of this publication, enclosures hereto and the information contained therein without EPCOS' prior express consent is prohibited.

EPCOS AG is a TDK Group Company.

**BC chokes (Bobbin Core)**  
**Rated inductance 1 ... 4700  $\mu$ H**  
**Rated current 55 ... 1200 mA**

### Construction

- Ferrite drum core
- Winding: enamel copper wire
- Flame-retardant lacquer coating

### Features

- Wide inductance range
- Suitable for general-purpose application
- Special versions available
- Suitable for wave soldering
- RoHS-compatible

### Applications

- RF blocking and filtering
- Decoupling and interference suppression
- For antenna systems, automotive electronics, energy-saving lamps, entertainment electronics

### Terminals

- Central axial leads (B78108S)
- Radially bent to 5 mm lead spacing (B78148S)
- Base material Cu
- Electroplated with nickel and pure tin

### Marking

Inductance indicated by color bands to IEC 60062

### Delivery mode and packing units

- Taped, Ammo and reel packing
- Packing units:

	Ammo (pcs./pack.)	Reel (pcs./reel)
Axial	2500	5000
Radial	2500	2000



B78108S



B78148S

**Dimensional drawings**

B78108S (axial leads, taped)

Dimensions in mm



Minimum lead spacing 12.5 mm

B78148S (central radial leads, taped)

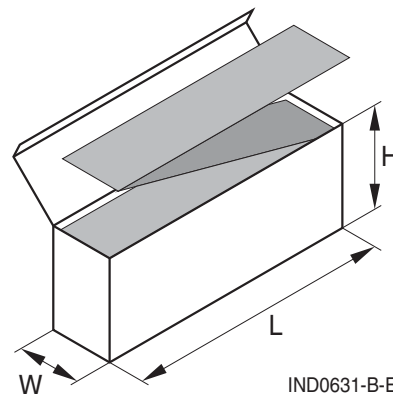
**Packing**

n (mm): Axial 72 +1, radial 42 +1  
 w (mm): Axial 84 max., radial 54 max.

L × W × H (max. mm):  
 Axial: 275 × 80 × 140, radial: 340 × 50 × 210

**Technical data and measuring conditions**

Rated inductance $L_R$	Measured with LCR meter Agilent 4284A or impedance analyzer Agilent 4294A Measuring frequency: $L_R \leq 10 \mu\text{H}$ = 1 MHz $10 \mu\text{H} < L_R \leq 4700 \mu\text{H}$ = 100 kHz Measuring current: $\leq 1 \text{ mA}$ Measuring temperature: +20 °C
Q factor $Q_{\min}$	Measured with precision impedance analyzer Agilent 4294A, +20 °C
Rated temperature $T_R$	+40 °C
Rated current $I_R$	Maximum permissible DC current at rated temperature
Inductance decrease $\Delta L/L_0$	$\leq 10\%$ (referred to initial value) at $I_R$ , +20 °C
DC resistance $R_{\max}$	Measured at 20 °C
Resonance frequency $f_{\text{res},\min}$	Measured with Agilent 4294A or 8753ES, +20 °C
Solderability (lead-free)	Sn95.5Ag3.8Cu0.7: +(245 ±5) °C, (3 ±0.3) s Wetting of soldering area $\geq 90\%$ (to IEC 60068-2-20, test Ta)
Resistance to soldering heat	+(260 ±5) °C, 10 s (to IEC 60068-2-20, test Tb)
Tensile strength of leads	$\geq 20 \text{ N}$ (to IEC 60068-2-21, test Ua)
Climatic category	55/125/56 (to IEC 60068-1)
Storage conditions	Mounted: -55 °C ... +125 °C Packaged: -25 °C ... +40 °C, $\leq 75\%$ RH
Weight	Approx. 0.38 g

 **Mounting information**

When bending the leads, take care that the start-of-winding areas at the face ends (protected by glue and lacquer) are not subjected to any mechanical stress.

**Characteristics and ordering codes**

$L_R$ $\mu\text{H}$	Tolerance <sup>1)</sup>	$Q_{\min}$	$f_Q$ MHz	$I_R$ mA	$R_{\max}$ $\Omega$	$f_{\text{res, min}}$ MHz	Ordering code <sup>2)</sup> (reel packing) <sup>3)</sup>
1.0	$\pm 10\% \triangleq K$	55	7.96	1200	0.16	205	B781*8S1102K000
1.2		55	7.96	1150	0.18	185	B781*8S1122K000
1.5		55	7.96	1100	0.20	165	B781*8S1152K000
1.8		55	7.96	1030	0.22	155	B781*8S1182K000
2.2		55	7.96	1000	0.25	140	B781*8S1222K000
2.7		60	7.96	940	0.26	125	B781*8S1272K000
3.3		60	7.96	900	0.29	115	B781*8S1332K000
3.9		60	7.96	850	0.31	105	B781*8S1392K000
4.7		60	7.96	820	0.34	95	B781*8S1472K000
5.6		60	7.96	780	0.38	85	B781*8S1562K000
6.8		65	7.96	670	0.51	75	B781*8S1682K000
8.2		65	7.96	690	0.48	50	B781*8S1822K000
10		70	2.52	680	0.49	35	B781*8S1103K000
12		70	2.52	650	0.55	30	B781*8S1123K000
15		60	2.52	610	0.60	20	B781*8S1153K000
18		60	2.52	580	0.67	17	B781*8S1183K000
22		55	2.52	560	0.74	13	B781*8S1223K000
27		55	2.52	530	0.83	10	B781*8S1273K000
33		55	2.52	500	0.92	9.0	B781*8S1333K000
39	50	2.52	470	1.02	8.0	B781*8S1393K000	

BC chokes with temperature range up to +140 °C on request.

BC chokes up to 33  $\mu\text{H}$  with higher resonance frequency on request.

1) Closer tolerances on request.

2) Replace the \* by code number »0« for axial taping or by »4« for radial taping.

3) For Ammo pack the last digit has to be a »9«. Example: B78108S1102K009

**Characteristics and ordering codes**

$L_R$ $\mu\text{H}$	Tolerance <sup>1)</sup>	$Q_{\min}$	$f_Q$ MHz	$I_R$ mA	$R_{\max}$ $\Omega$	$f_{\text{res, min}}$ MHz	Ordering code <sup>2)</sup> (reel packing) <sup>3)</sup>
47	$\pm 5\% \triangleq J$	45	2.52	450	1.10	7.5	B781*8S1473J000
56		40	2.52	430	1.23	7.0	B781*8S1563J000
68		40	2.52	410	1.35	6.5	B781*8S1683J000
82		35	2.52	390	1.54	6.0	B781*8S1823J000
100		70	0.796	370	1.70	5.0	B781*8S1104J000
120		70	0.796	300	2.40	4.5	B781*8S1124J000
150		70	0.796	280	2.80	4.2	B781*8S1154J000
180		70	0.796	270	3.00	3.9	B781*8S1184J000
220		70	0.796	250	3.30	3.7	B781*8S1224J000
270		70	0.796	200	5.70	2.8	B781*8S1274J000
330		70	0.796	190	6.40	2.7	B781*8S1334J000
390		70	0.796	180	7.00	2.4	B781*8S1394J000
470		70	0.796	170	7.90	2.2	B781*8S1474J000
560		60	0.796	160	8.80	2.0	B781*8S1564J000
680		55	0.796	150	10.0	1.9	B781*8S1684J000
820		50	0.796	140	12.0	1.6	B781*8S1824J000
1000		50	0.252	130	14.0	1.6	B781*8S1105J000
1200		50	0.252	115	17.5	1.3	B781*8S1125J000
1500		50	0.252	100	23.0	1.25	B781*8S1155J000
1800		50	0.252	95	26.0	1.2	B781*8S1185J000
2200		40	0.252	80	34.7	1.1	B781*8S1225J000
2700	40	0.252	75	40.0	1.0	B781*8S1275J000	
3300	40	0.252	62	59.5	0.9	B781*8S1335J000	
3900	40	0.252	59	66.0	0.8	B781*8S1395J000	
4700	35	0.252	55	78.0	0.7	B781*8S1475J000	

BC chokes with temperature range up to +140 °C on request.

1) Closer tolerances on request.

2) Replace the \* by code number »0« for axial taping or by »4« for radial taping.

3) For Ammo pack the last digit has to be a »9«. Example: B78108S1473J009

**Impedance  $|Z|$  versus frequency  $f$**   
 measured with impedance analyzer Agilent 4294A or S-parameter network analyzer Agilent 8753ES, typical values at +20 °C



**Inductance  $L$  versus DC load current  $I_{DC}$**   
 measured with LCR meter Agilent 4284A, typical values at +20 °C



**Q factor versus frequency  $f$**   
 measured with impedance analyzer Agilent 4294A, typical values at +20 °C



**Current derating  $I_{op}/I_R$  versus ambient temperature  $T_A$**   
 (rated temperature  $T_R = +40$  °C)

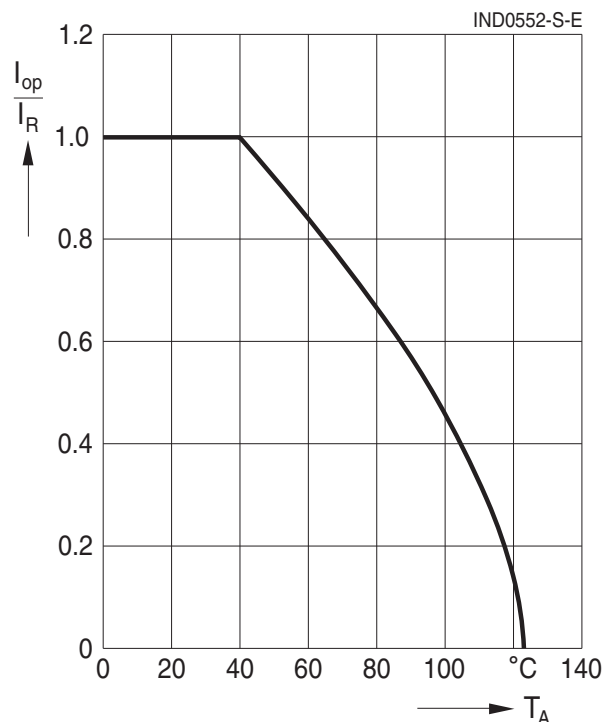

## Cautions and warnings

- Please note the recommendations in our Inductors data book (latest edition) and in the data sheets.
  - Particular attention should be paid to the derating curves given there.
  - The soldering conditions should also be observed. Temperatures quoted in relation to wave soldering refer to the pin, not the housing.
- If the components are to be washed varnished it is necessary to check whether the washing varnish agent that is used has a negative effect on the wire insulation, any plastics that are used, or on glued joints. In particular, it is possible for washing varnish agent residues to have a negative effect in the long-term on wire insulation.  
Washing processes may damage the product due to the possible static or cyclic mechanical loads (e.g. ultrasonic cleaning). They may cause cracks to develop on the product and its parts, which might lead to reduced reliability or lifetime.
- The following points must be observed if the components are potted in customer applications:
  - Many potting materials shrink as they harden. They therefore exert a pressure on the plastic housing or core. This pressure can have a deleterious effect on electrical properties, and in extreme cases can damage the core or plastic housing mechanically.
  - It is necessary to check whether the potting material used attacks or destroys the wire insulation, plastics or glue.
  - The effect of the potting material can change the high-frequency behaviour of the components.
- Ferrites are sensitive to direct impact. This can cause the core material to flake, or lead to breakage of the core.
- Even for customer-specific products, conclusive validation of the component in the circuit can only be carried out by the customer.



## Important notes

The following applies to all products named in this publication:

1. Some parts of this publication contain **statements about the suitability of our products for certain areas of application**. These statements are based on our knowledge of typical requirements that are often placed on our products in the areas of application concerned. We nevertheless expressly point out **that such statements cannot be regarded as binding statements about the suitability of our products for a particular customer application**. As a rule, EPCOS is either unfamiliar with individual customer applications or less familiar with them than the customers themselves. For these reasons, it is always ultimately incumbent on the customer to check and decide whether an EPCOS product with the properties described in the product specification is suitable for use in a particular customer application.
2. We also point out that **in individual cases, a malfunction of electronic components or failure before the end of their usual service life cannot be completely ruled out in the current state of the art, even if they are operated as specified**. In customer applications requiring a very high level of operational safety and especially in customer applications in which the malfunction or failure of an electronic component could endanger human life or health (e.g. in accident prevention or life-saving systems), it must therefore be ensured by means of suitable design of the customer application or other action taken by the customer (e.g. installation of protective circuitry or redundancy) that no injury or damage is sustained by third parties in the event of malfunction or failure of an electronic component.
3. **The warnings, cautions and product-specific notes must be observed.**
4. In order to satisfy certain technical requirements, **some of the products described in this publication may contain substances subject to restrictions in certain jurisdictions (e.g. because they are classed as hazardous)**. Useful information on this will be found in our Material Data Sheets on the Internet ([www.epcos.com/material](http://www.epcos.com/material)). Should you have any more detailed questions, please contact our sales offices.
5. We constantly strive to improve our products. Consequently, **the products described in this publication may change from time to time**. The same is true of the corresponding product specifications. Please check therefore to what extent product descriptions and specifications contained in this publication are still applicable before or when you place an order.

We also **reserve the right to discontinue production and delivery of products**. Consequently, we cannot guarantee that all products named in this publication will always be available. The aforementioned does not apply in the case of individual agreements deviating from the foregoing for customer-specific products.

6. Unless otherwise agreed in individual contracts, **all orders are subject to the current version of the “General Terms of Delivery for Products and Services in the Electrical Industry” published by the German Electrical and Electronics Industry Association (ZVEI)**.
7. The trade names EPCOS, BAOKE, Alu-X, CeraDiode, CeraLink, CSMP, CSSP, CTVS, DeltaCap, DigiSiMic, DSSP, FilterCap, FormFit, MiniBlue, MiniCell, MKD, MKK, MLSC, MotorCap, PCC, PhaseCap, PhaseCube, PhaseMod, PhiCap, SIFERRIT, SIFI, SIKOREL, SilverCap, SIMDAD, SiMic, SIMID, SineFormer, SIOV, SIP5D, SIP5K, ThermoFuse, WindCap are **trademarks registered or pending** in Europe and in other countries. Further information will be found on the Internet at [www.epcos.com/trademarks](http://www.epcos.com/trademarks).