



Ferrites and accessories

EP7

Core and accessories

Series/Type: B65839, B65840

The following products presented in this data sheet are being withdrawn.

Ordering Code	Substitute Product	Date of Withdrawal	Deadline Last Orders	Last Shipments
B65840D2000X000		2013-05-29	2013-08-31	2013-11-30

For further information please contact your nearest EPCOS sales office, which will also support you in selecting a suitable substitute. The addresses of our worldwide sales network are presented at www.epcos.com/sales.

© EPCOS AG 2015. Reproduction, publication and dissemination of this publication, enclosures hereto and the information contained therein without EPCOS' prior express consent is prohibited.

EPCOS AG is a TDK Group Company.

EP 7

Core

B65839

- To IEC 61596
- For transformers featuring high inductance and low overall height
- For power applications
- Delivery mode: sets

Magnetic characteristics (per set)

$\Sigma l/A = 1.52 \text{ mm}^{-1}$
 $l_e = 15.7 \text{ mm}$
 $A_e = 10.3 \text{ mm}^2$
 $A_{min} = 8.5 \text{ mm}^2$
 $V_e = 162 \text{ mm}^3$

Approx. weight 1.4 g/set

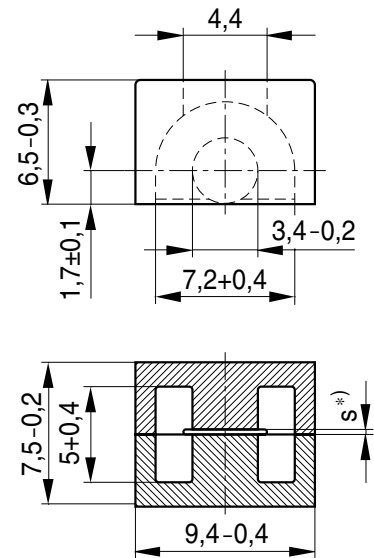

*) gapped (one-sided)

FEP0004-T

Gapped

Material	A_L value nH	s approx. mm	μ_e	Ordering code
T38	63 ±3%	0.20	76	B65839A0063A038
	100 ±3%	0.13	121	B65839A0100A038
	160 ±5%	0.08	194	B65839A0160J038
	200 ±6%	0.06	243	B65839A0200C038
	250 ±7%	0.05	303	B65839A0250E038
T57	63 ±3%	0.20	76	B65839A0063A057
	100 ±3%	0.13	121	B65839A0100A057
	160 ±5%	0.08	194	B65839A0160J057
	200 ±6%	0.06	243	B65839A0200C057
	250 ±7%	0.05	303	B65839A0250E057
N45	63 ±3%	0.20	76	B65839A0063A045
	100 ±3%	0.13	121	B65839A0100A045
	160 ±5%	0.08	194	B65839A0160J045
	200 ±6%	0.06	243	B65839A0200C045
	250 ±7%	0.05	303	B65839A0250E045
N87	63 ±3%	0.20	76	B65839A0063A087
	100 ±3%	0.12	121	B65839A0100A087
	160 ±5%	0.07	194	B65839A0160J087
	200 ±6%	0.06	243	B65839A0200C087
	250 ±7%	0.05	303	B65839A0250E087

EP 7

Core

B65839

Ungapped

Material	A _L value nH	μ _e	P _V W/set	Ordering code
T57	1500 +30/-20%	1820		B65839A0000R057
N45	1500 +30/-20%	1820		B65839A0000R045
N30	2000 +30/-20%	2430		B65839A0000R030
T65	3000 +30/-20%	3640		B65839A0000R065
T38	5200 +40/-30%	6310		B65839A0000Y038
T66	5800 +40/-30%	7040		B65839A0000Y066
N87	1100 +30/-20%	1330	< 0.08 (200 mT, 100 kHz, 100 °C)	B65839A0000R087

Coil former

Material: GFR thermosetting plastic (UL 94 V-0, insulation class to IEC 60085: F \triangleq max. operating temperature 155 °C), color code green
 Vyncolit/X611® [E167521 (M)], VYNCOLIT NV

Solderability: to IEC 60068-2-20, test Ta, method 1 (aging 3): 235 °C, 2 s

Resistance to soldering heat: to IEC 60068-2-20, test Tb, method 1B: 350 °C, 3.5 s

Winding: see Data Book 2007, chapter "Processing notes, 2.1"

Squared pins.

Cap yoke

With ground terminal, made of stainless spring steel (tinned), 0.25 mm thick

Coil former					Ordering code
Sections	A _N mm ²	l _N mm	A _R value μΩ	Terminals	
1	4.7	17.7	128.7	6	B65840B1006D001
2	4.2	17.7	143.8	6	B65840B1006D002
Cap yoke					B65840D2000X000

Coil former

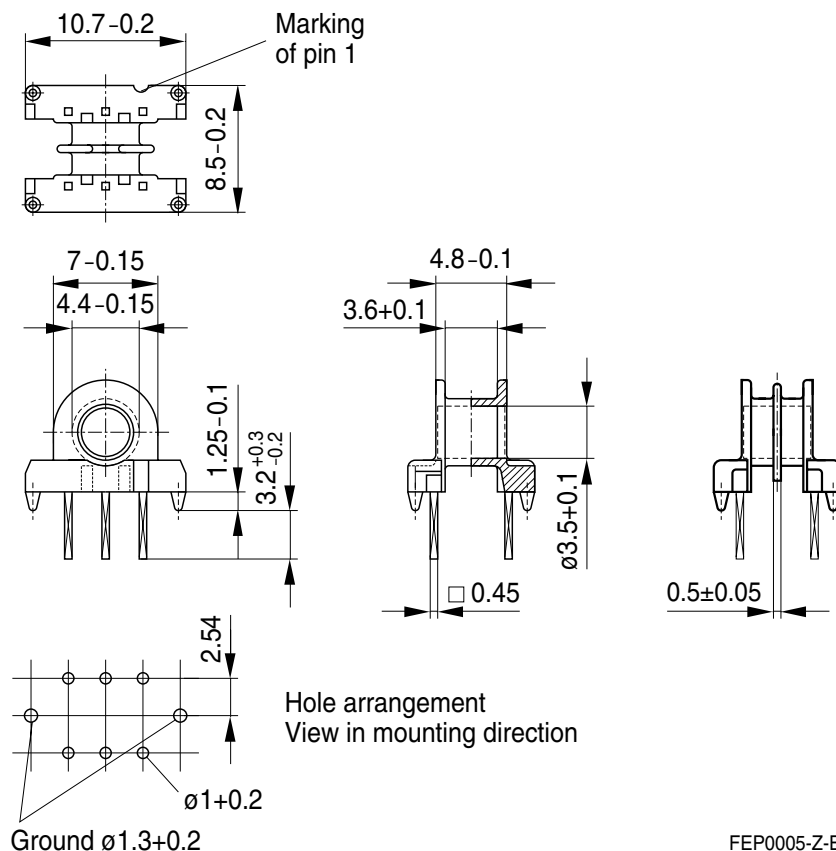

Cap yoke

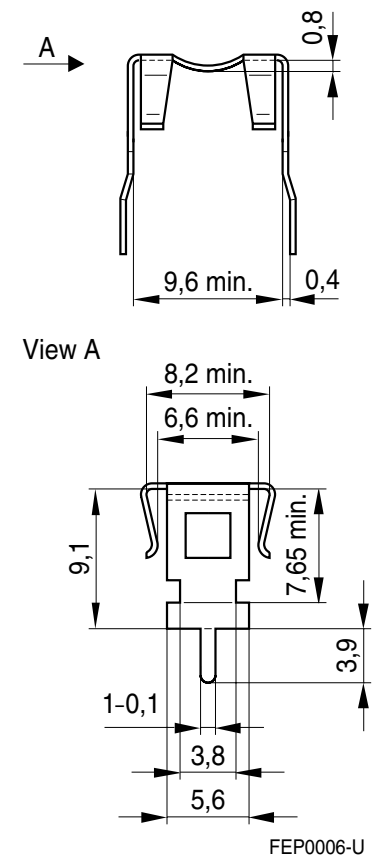

FEP0005-Z-E

FEP0006-U

Preliminary data



SMD coil former with gullwing terminals

Material: GFR liquid crystal polymer (UL 94 V-0), color code black

Sumika Super E4008® [E54705 (M)], SUMITOMO CHEMICAL CO LTD

Solderability: to IEC 60068-2-58, test Td, method 6 (Group 3): 245 °C, 3 s

Resistance to soldering heat: to IEC 60068-2-58, test Td, method 6 (Group 3): 255 °C, 10 s
 permissible soldering temperature for wire-wrap connection on coil former: 400 °C, 1 s

Sections	A _N mm ²	l _N mm	A _R value μΩ	Terminals	Ordering code
1	4.5	18.1	138.1	6	B65840N1106T001

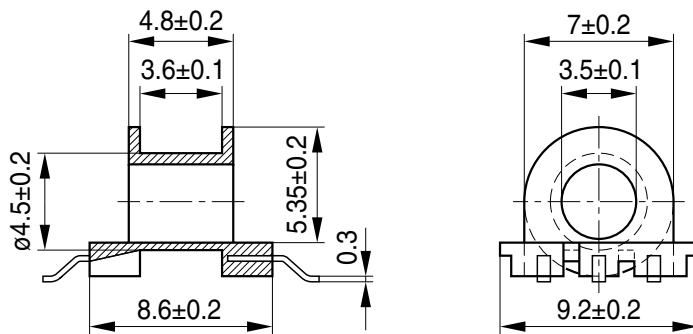

Recommended
PCB layout

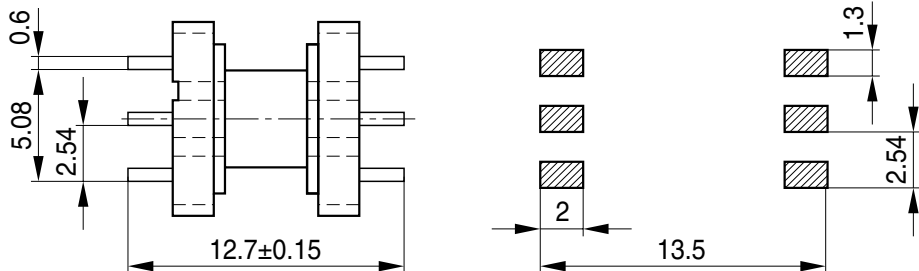

FEK0475-T-E

Mechanical stress and mounting

Ferrite cores have to meet mechanical requirements during assembling and for a growing number of applications. Since ferrites are ceramic materials one has to be aware of the special behavior under mechanical load.

As valid for any ceramic material, ferrite cores are brittle and sensitive to any shock, fast changing or tensile load. Especially high cooling rates under ultrasonic cleaning and high static or cyclic loads can cause cracks or failure of the ferrite cores.

For detailed information see Data Book 2007, chapter “General – Definitions, 8.1”.

Effects of core combination on A_L value

Stresses in the core affect not only the mechanical but also the magnetic properties. It is apparent that the initial permeability is dependent on the stress state of the core. The higher the stresses are in the core, the lower is the value for the initial permeability. Thus the embedding medium should have the greatest possible elasticity.

For detailed information see Data Book 2007, chapter “General – Definitions, 8.2”.

Heating up

Ferrites can run hot during operation at higher flux densities and higher frequencies.

NiZn-materials

The magnetic properties of NiZn-materials can change irreversible in high magnetic fields.

Processing notes

- The start of the winding process should be soft. Else the flanges may be destroyed.
- To strong winding forces may blast the flanges or squeeze the tube that the cores can no more be mount.
- To long soldering time at high temperature (>300 °C) may effect coplanarity or pin arrangement.
- Not following the processing notes for soldering of the J-leg terminals may cause solderability problems at the transformer because of pollution with Sn oxyd of the tin bath or burned insulation of the wire. For detailed information see Data Book 2007, chapter “Processing notes, 2.2”.
- The dimensions of the hole arrangement have fixed values and should be understood as a recommendation for drilling the printed circuit board. For dimensioning the pins, the group of holes can only be seen under certain conditions, as they fit into the given hole arrangement. To avoid problems when mounting the transformer, the manufacturing tolerances for positioning the customers’ drilling process must be considered by increasing the hole diameter.

Important notes

The following applies to all products named in this publication:

1. Some parts of this publication contain **statements about the suitability of our products for certain areas of application**. These statements are based on our knowledge of typical requirements that are often placed on our products in the areas of application concerned. We nevertheless expressly point out **that such statements cannot be regarded as binding statements about the suitability of our products for a particular customer application**. As a rule, EPCOS is either unfamiliar with individual customer applications or less familiar with them than the customers themselves. For these reasons, it is always ultimately incumbent on the customer to check and decide whether an EPCOS product with the properties described in the product specification is suitable for use in a particular customer application.
2. We also point out that **in individual cases, a malfunction of passive electronic components or failure before the end of their usual service life cannot be completely ruled out in the current state of the art, even if they are operated as specified**. In customer applications requiring a very high level of operational safety and especially in customer applications in which the malfunction or failure of a passive electronic component could endanger human life or health (e.g. in accident prevention or life-saving systems), it must therefore be ensured by means of suitable design of the customer application or other action taken by the customer (e.g. installation of protective circuitry or redundancy) that no injury or damage is sustained by third parties in the event of malfunction or failure of a passive electronic component.
3. **The warnings, cautions and product-specific notes must be observed.**
4. In order to satisfy certain technical requirements, **some of the products described in this publication may contain substances subject to restrictions in certain jurisdictions (e.g. because they are classed as “hazardous”)**. Useful information on this will be found in our Material Data Sheets on the Internet (www.epcos.com/material). Should you have any more detailed questions, please contact our sales offices.
5. We constantly strive to improve our products. Consequently, **the products described in this publication may change from time to time**. The same is true of the corresponding product specifications. Please check therefore to what extent product descriptions and specifications contained in this publication are still applicable before or when you place an order.
We also **reserve the right to discontinue production and delivery of products**. Consequently, we cannot guarantee that all products named in this publication will always be available.
6. Unless otherwise agreed in individual contracts, **all orders are subject to the current version of the “General Terms of Delivery for Products and Services in the Electrical Industry” published by the German Electrical and Electronics Industry Association (ZVEI)**.
7. The trade names EPCOS, EPCOS-JONES, Baoke, Alu-X, CeraDiode, CSSP, MLSC, PhaseCap, PhaseMod, SIFI, SIFERRIT, SIKOREL, SilverCap, SIMID, SIOV, SIP5D, SIP5K, UltraCap, WindCap are **trademarks registered or pending** in Europe and in other countries. Further information will be found on the Internet at www.epcos.com/trademarks.