

ohne / without

Mutter / nut

max. Einschraubtiefe 7,5 mm
thread depth max. 7,5 mm

Bolzen / bolt

max. Einschraubtiefe 5,5 mm
thread depth max. 5,5 mm

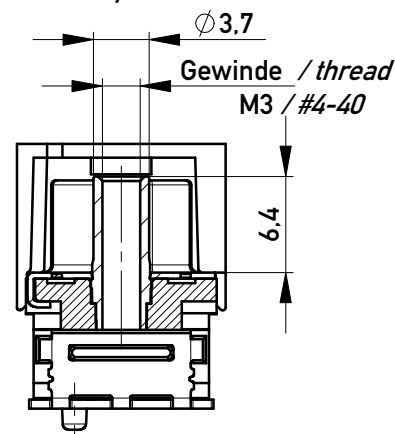
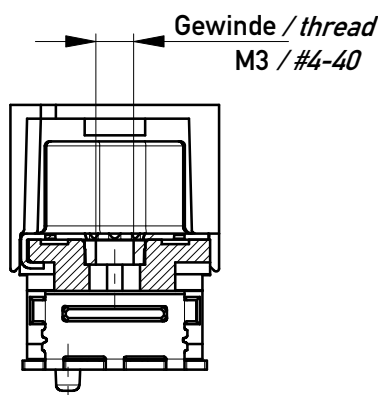
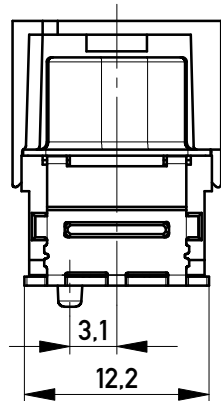

M 1:1

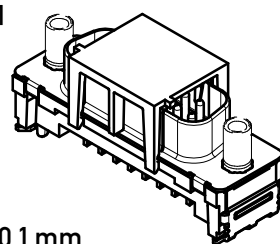

Anschlussbereich verzinkt
terminal area tin plating

Koplanarität der Anschlüsse ≤ 0,1 mm
coplanarity area of termination ≤ 0,1 mm

Anforderungsstufe: 2
class: 2

194305	194300	X			
194306	194301			#4-40	
194307	194302			M3	
194308	194303		#4-40		
194309	194304		M3		
Ident.-Nr. part-no. tape & reel	Ident.-Nr. part-no. tray	ohne without	Mutter thread	Bolzen bolt	Bemerkung remark

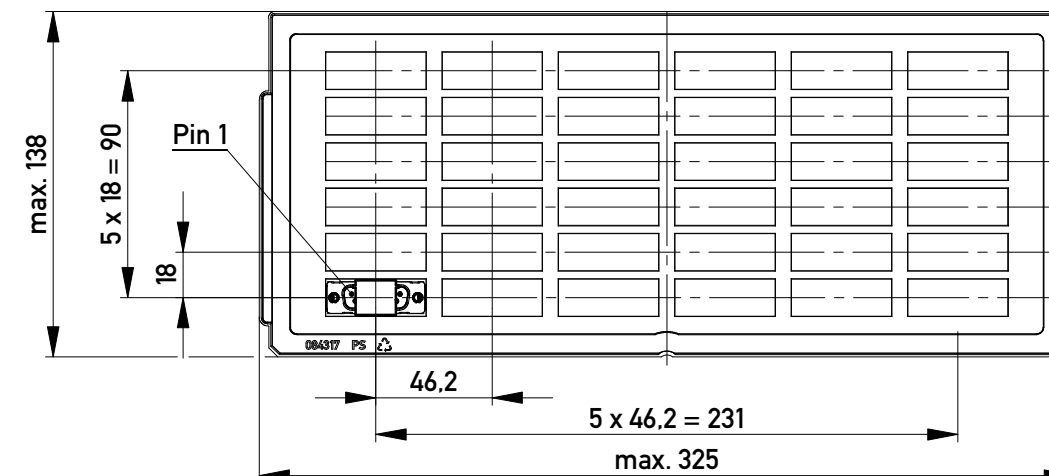

Verpackt in Tray
Verpackungseinheit 36 St.
tray packaging
packaging unit 36 pcs

Sonstige Angaben siehe Zeichnung 204628 / Additional indications according to drawing 204628

Verpackt im Gurt in Anlehnung an DIN IEC 60286-3
Tape on Reel Packaging according to DIN IEC 60286-3
Verpackungseinheit: 75 Stück
Packaging unit: 75 pcs

Abspulrichtung - Reel off Direction

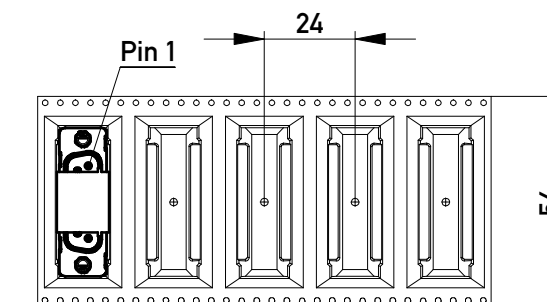
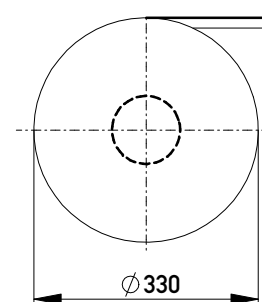

Sonstige Angaben siehe Zeichnung 204654 / Additional indications according to drawing 204654

Layoutvorschlag:
recommended layout:

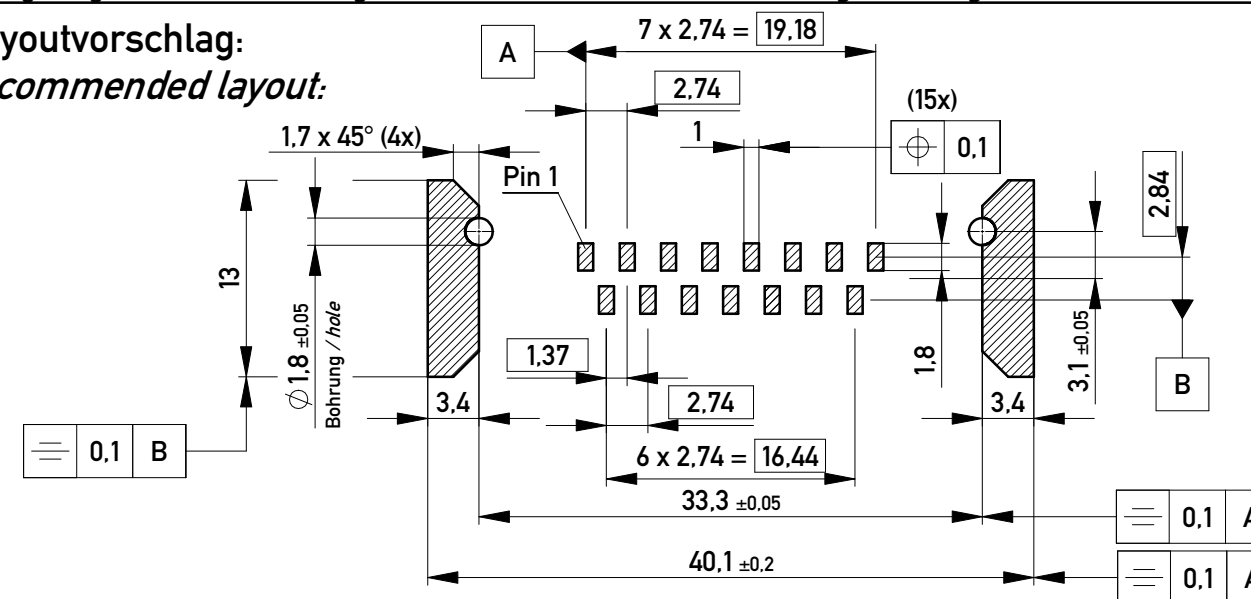

Fehlende Masse und Angaben siehe DIN 41652 / Missing information and dimensions according to DIN 41652
Sonstige Angaben siehe Fertigungsunterlagen / Additional indications according to the production documentation

Information:	Tolerances	Scale	2:1
All rights reserved. Only for Information. To ensure that this is the latest version of this drawing, please contact one of the ERNI companies before using.	Subject to modification without prior notice. Drawing will not be updated.	Designation	TMC-P 15-SMD-9,0-BA8 TMC-P 15-SMD-9,0-type 8
g	04.02.2016	www.ERNI.com	144908
Index	Date	ERNI	1 A3
		Class	TMCP