

EMK23H2H-20.000M

[Click part number to visit Part Number Details page](#)

REGULATORY COMPLIANCE (Data Sheet downloaded on May 22, 2017)

[Click badges to download compliance docs](#)

Regulatory Compliance standards are subject to updates by governing bodies. Click the badges to download the latest compliance docs for this part number directly from Ecliptek.



ITEM DESCRIPTION

MEMS Clock Oscillators LVCMOS (CMOS) 3.3Vdc 4 Pad 3.2mm x 5.0mm Plastic Surface Mount (SMD) 20.000MHz \pm 50ppm over -40°C to +85°C

ELECTRICAL SPECIFICATIONS

| | |
|---------------------------------|---|
| Nominal Frequency | 20.000MHz |
| Frequency Tolerance/Stability | \pm 50ppm Maximum over -40°C to +85°C (Inclusive of all conditions: Calibration Tolerance at 25°C, Frequency Stability over the Operating Temperature Range, Supply Voltage Change, Output Load Change, First Year Aging at 25°C, 260°C Reflow, Shock, and Vibration) |
| Aging at 25°C | \pm 1ppm Maximum First Year |
| Supply Voltage | 3.3Vdc \pm 10% |
| Input Current | 20mA Maximum |
| Output Voltage Logic High (Voh) | 90% of Vdd Minimum (IOH=-8mA) |
| Output Voltage Logic Low (Vol) | 10% of Vdd Maximum (IOL=+8mA) |
| Rise/Fall Time | 2nSec Maximum (Measured from 20% to 80% of waveform) |
| Duty Cycle | 50 \pm 5(%) (Measured at 50% of waveform) |
| Load Drive Capability | 15pF Maximum |
| Output Logic Type | CMOS |
| Output Control Function | Tri-State (Disabled Output: High Impedance) |
| Output Control Input Voltage | +0.7Vdd Minimum or No Connect to Enable Output, +0.3Vdd Maximum to Disable Output |
| Peak to Peak Jitter (tPK) | 250pSec Maximum, 100pSec Typical |
| Start Up Time | 50mSec Maximum |
| Storage Temperature Range | -55°C to +125°C |

ENVIRONMENTAL & MECHANICAL SPECIFICATIONS

| | |
|------------------------------|---|
| ESD Susceptibility | MIL-STD-883, Method 3015, Class 2, HBM 2000V |
| Flammability | UL94-V0 |
| Mechanical Shock | MIL-STD-883, Method 2002, Condition G, 30,000G |
| Moisture Resistance | MIL-STD-883, Method 1004 |
| Moisture Sensitivity Level | J-STD-020, MSL 1 |
| Resistance to Soldering Heat | MIL-STD-202, Method 210, Condition K |
| Resistance to Solvents | MIL-STD-202, Method 215 |
| Solderability | MIL-STD-883, Method 2003 (Pads on bottom of package only) |
| Temperature Cycling | MIL-STD-883, Method 1010, Condition B |
| Thermal Shock | MIL-STD-883, Method 1011, Condition B |
| Vibration | MIL-STD-883, Method 2007, Condition A, 20G |

EMK23H2H-20.000M [Click part number to visit Part Number Details page](#)

MECHANICAL DIMENSIONS (all dimensions in millimeters)

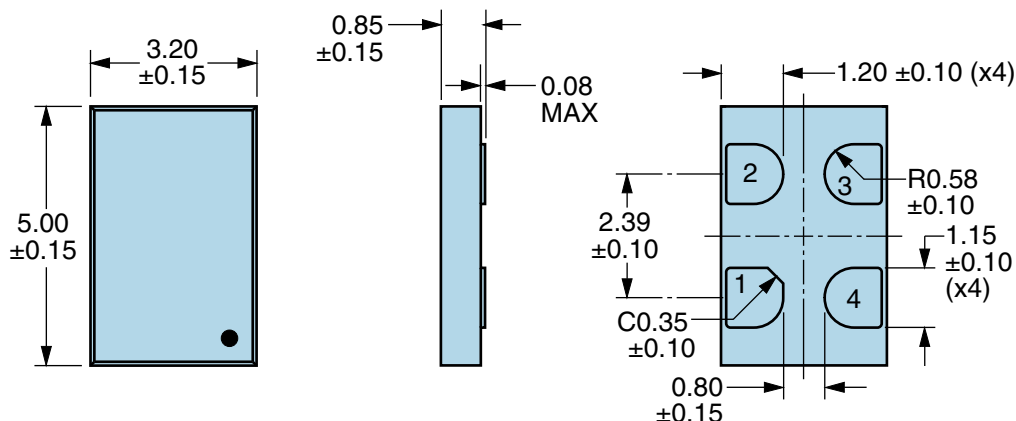

| PIN | CONNECTION |
|-----|----------------|
| 1 | Tri-State |
| 2 | Ground |
| 3 | Output |
| 4 | Supply Voltage |

| LINE | MARKING |
|------|---|
| 1 | XXXX or XXXXX XXXX or XXXXX=Ecliptek Manufacturing Lot Code |

Suggested Solder Pad Layout

All Dimensions in Millimeters

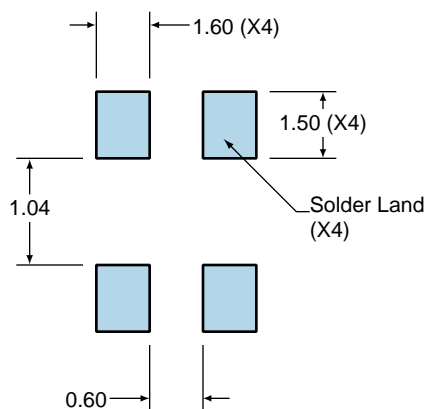

All Tolerances are ± 0.1

EMK23H2H-20.000M [Click part number to visit Part Number Details page](#)

OUTPUT WAVEFORM & TIMING DIAGRAM

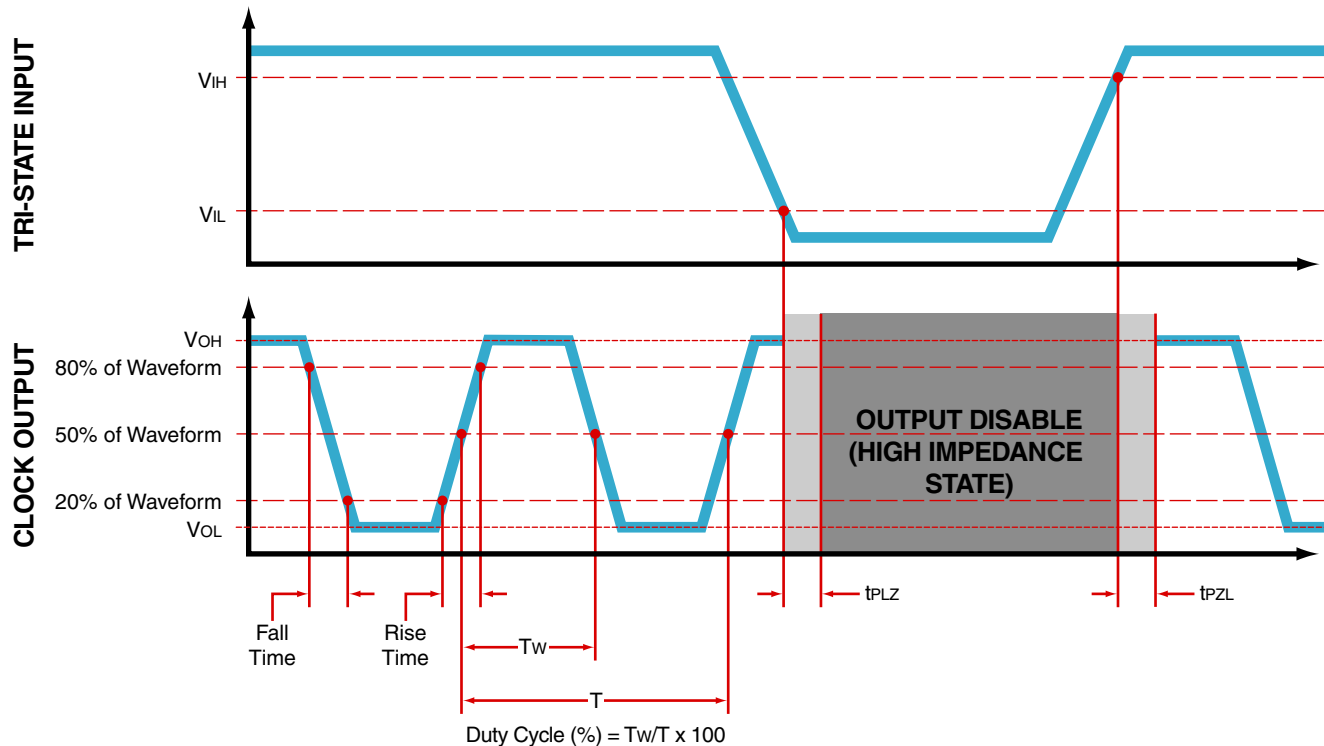

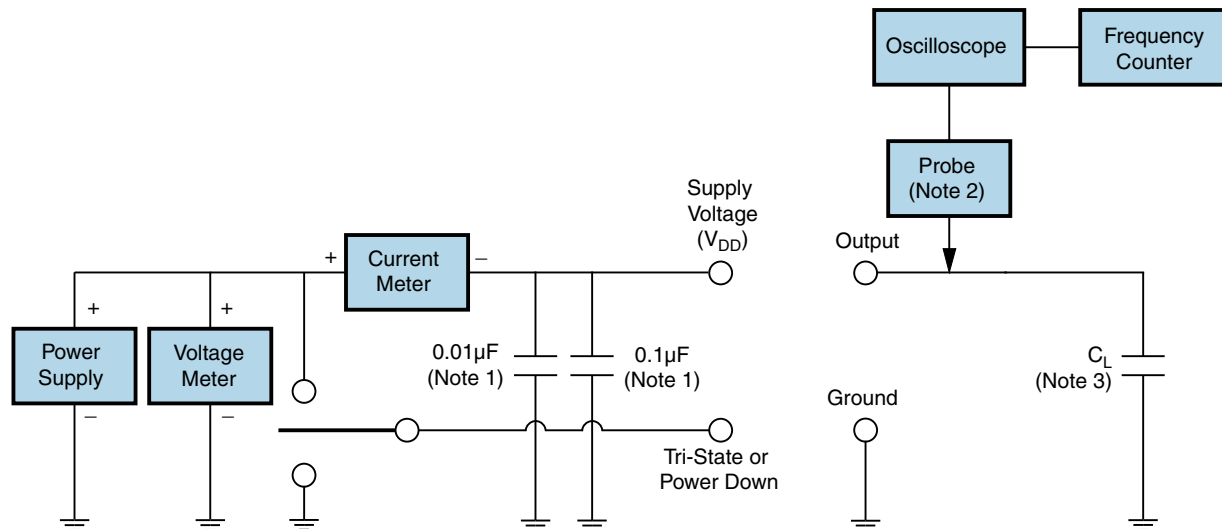
Test Circuit for CMOS Output

Note 1: An external $0.01\mu\text{F}$ ceramic bypass capacitor in parallel with a $0.1\mu\text{F}$ high frequency ceramic bypass capacitor close (less than 2mm) to the package ground and supply voltage pin is required.

Note 2: A low input capacitance ($<12\text{pF}$), 10X Attenuation Factor, High Impedance ($>10\text{Mohms}$), and High bandwidth ($>300\text{MHz}$) passive probe is recommended.

Note 3: Capacitance value C_L includes sum of all probe and fixture capacitance. See applicable specification sheet for 'Load Drive Capability'.

EMK23H2H-20.000M

[Click part number to visit Part Number Details page](#)

Recommended Solder Reflow Methods

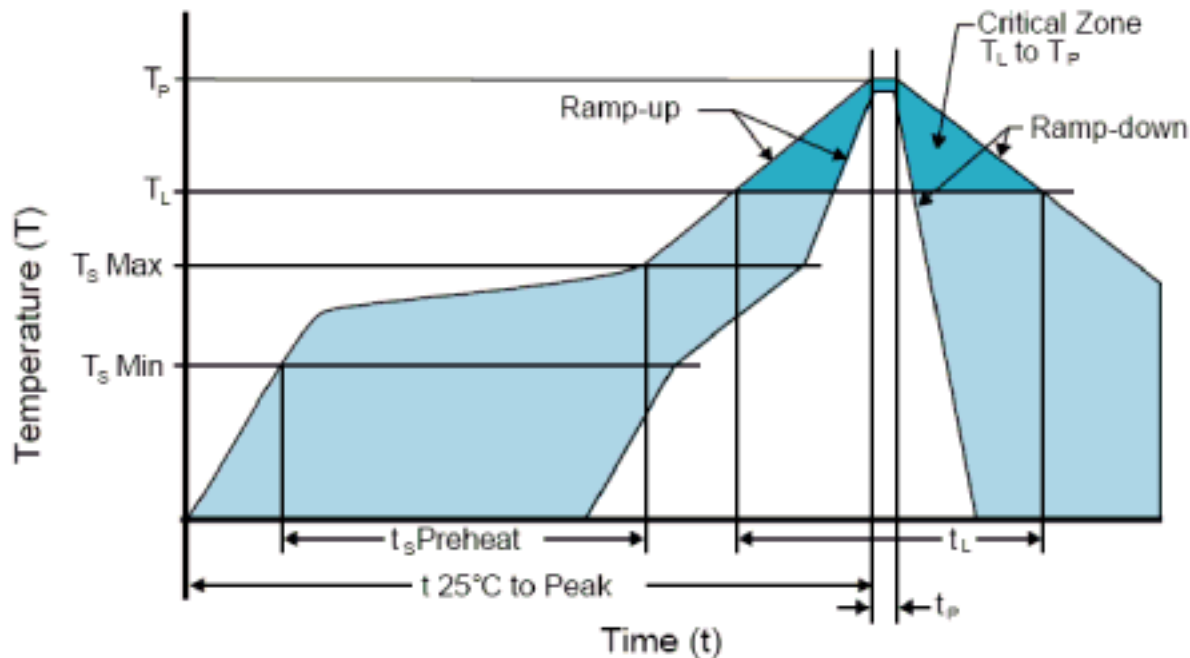

High Temperature Infrared/Convection

| | |
|--|---|
| Ts MAX to TL (Ramp-up Rate) | 3°C/Second Maximum |
| Preheat | |
| - Temperature Minimum (Ts MIN) | 150°C |
| - Temperature Typical (Ts TYP) | 175°C |
| - Temperature Maximum (Ts MAX) | 200°C |
| - Time (ts MIN) | 60 - 180 Seconds |
| Ramp-up Rate (TL to TP) | 3°C/Second Maximum |
| Time Maintained Above: | |
| - Temperature (TL) | 217°C |
| - Time (tL) | 60 - 150 Seconds |
| Peak Temperature (TP) | 260°C Maximum for 10 Seconds Maximum |
| Target Peak Temperature (TP Target) | 250°C +0/-5°C |
| Time within 5°C of actual peak (tp) | 20 - 40 Seconds |
| Ramp-down Rate | 6°C/Second Maximum |
| Time 25°C to Peak Temperature (t) | 8 Minutes Maximum |
| Moisture Sensitivity Level | Level 1 |
| Additional Notes | Temperatures shown are applied to body of device. |

EMK23H2H-20.000M

[Click part number to visit Part Number Details page](#)

Recommended Solder Reflow Methods

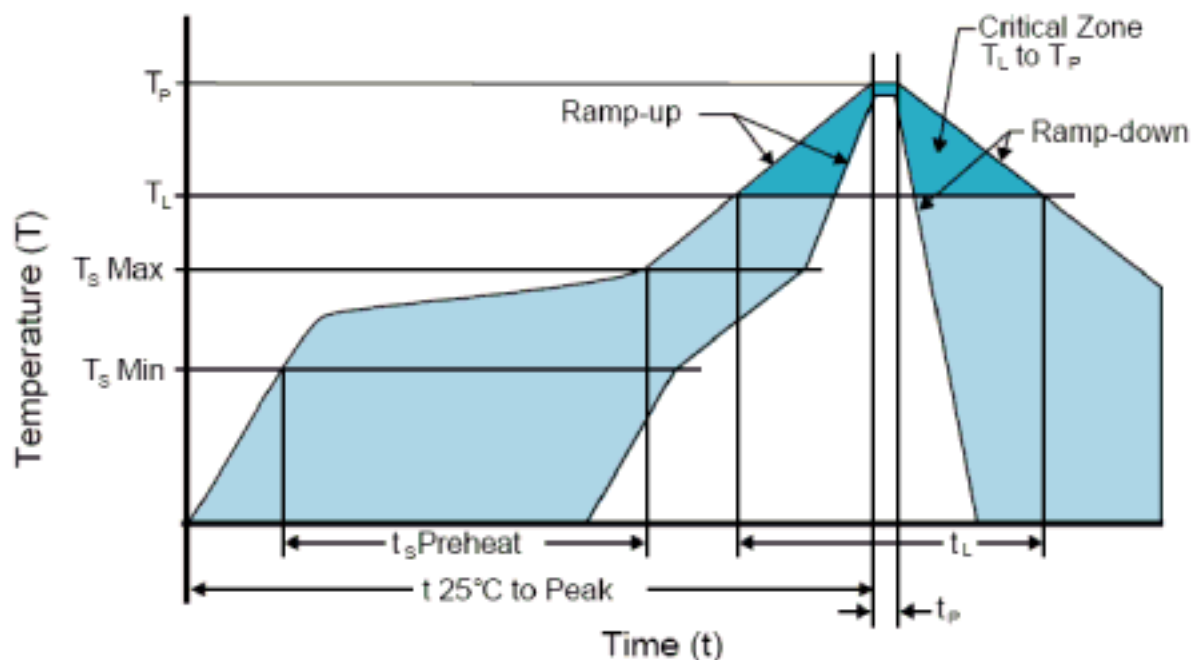

Low Temperature Infrared/Convection 240°C

| | |
|--|--|
| $T_S \text{ MAX to } T_L$ (Ramp-up Rate) | 5°C/Second Maximum |
| Preheat | |
| - Temperature Minimum ($T_S \text{ MIN}$) | N/A |
| - Temperature Typical ($T_S \text{ TYP}$) | 150°C |
| - Temperature Maximum ($T_S \text{ MAX}$) | N/A |
| - Time ($t_s \text{ MIN}$) | 60 - 120 Seconds |
| Ramp-up Rate (T_L to T_P) | 5°C/Second Maximum |
| Time Maintained Above: | |
| - Temperature (T_L) | 150°C |
| - Time (t_L) | 200 Seconds Maximum |
| Peak Temperature (T_P) | 240°C Maximum |
| Target Peak Temperature ($T_P \text{ Target}$) | 240°C Maximum 2 Times / 230°C Maximum 1 Time |
| Time within 5°C of actual peak (t_p) | 10 Seconds Maximum 2 Times / 80 Seconds Maximum 1 Time |
| Ramp-down Rate | 5°C/Second Maximum |
| Time 25°C to Peak Temperature (t) | N/A |
| Moisture Sensitivity Level | Level 1 |
| Additional Notes | Temperatures shown are applied to body of device. |

Low Temperature Manual Soldering

185°C Maximum for 10 Seconds Maximum, 2 times Maximum. (Temperatures shown are applied to body of device.)

High Temperature Manual Soldering

260°C Maximum for 5 Seconds Maximum, 2 times Maximum. (Temperatures shown are applied to body of device.)