

LOW QUIESCENT CURRENT PFM STEP DOWN CONVERTERS

PRODUCTION DATA - AUG 13, 2015



Features

- ▶ Wide input voltage range 4.5V to 40V
- ▶ PFM regulator up to 1.33MHz
- ▶ Up to >92% efficiency
- ▶ Very low 8µA sleep mode current
- ▶ Ultra low 12µA standby current
- ▶ 100% duty cycle capability
- ▶ Small QFN20L4 lead-less package
- ▶ TSSOP16 package
- ▶ AEC-Q100 qualification
- ▶ Junction temperature range -40°C to +150°C

Applications

- ▶ Micro Controller Systems
- ▶ Automotive Telematics, Dashboards
- ▶ Partial Networking
- ▶ Peripheral Control Systems

Ordering Information

Please find the ordering information in chapter „10 Product Ordering Information“

General Description

The E522.01/02/03/04/05/06/07/08/09 product family provides ultra low quiescent current step down DC/DC converters with integrated power MOSFET.

The PFM (Pulse Frequency Modulation) regulator allows outstanding fast line- and load response time, stability and high efficiency over the full load current range. The integrated idle detection assures an ultra low idle current and high efficiency with low load currents down to <100µA for the completely powered application. A power-good signal is provided by a high-voltage open-drain low-side switch.

The E522.0x buck converter accommodates to common single supply micro controller applications. Low external component count and small QFN20L4 / TSSOP16 package allow compact PCB designs.

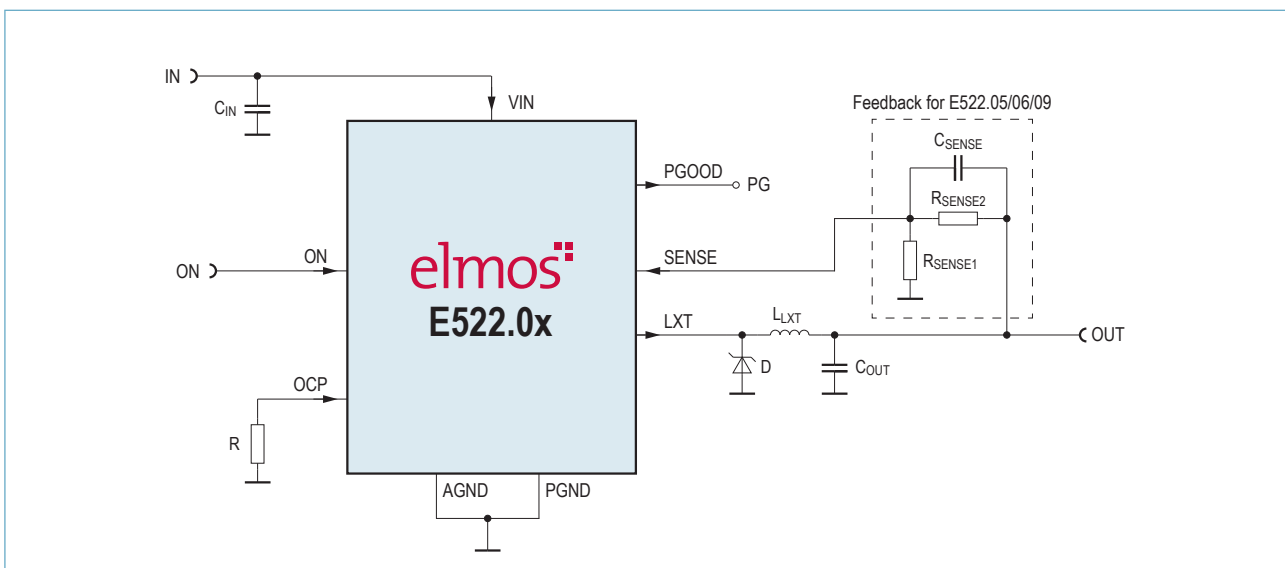

Elmos Semiconductor AG reserves the right to change the detail specifications as may be required to permit improvements in the design of its products.

1 Functional Diagram

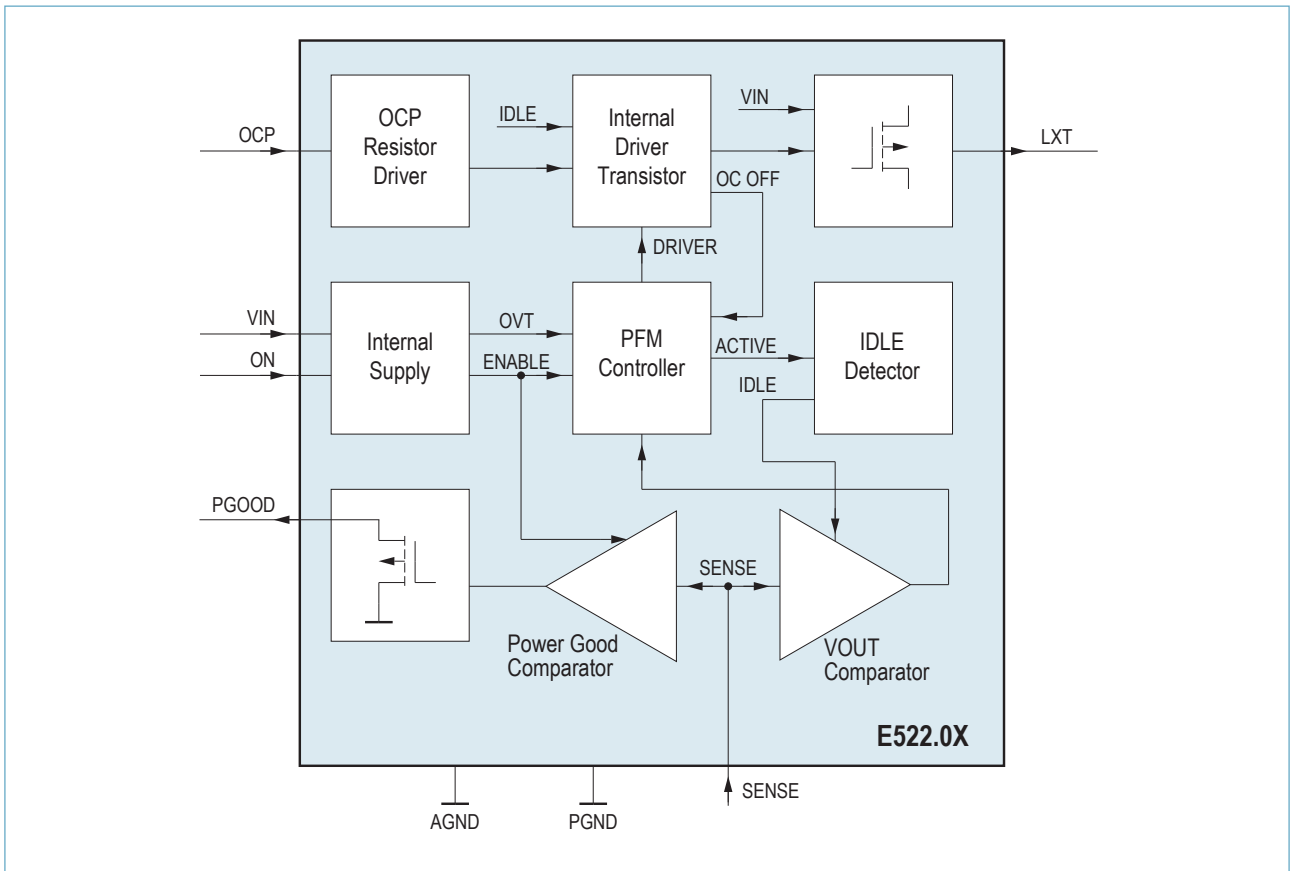

Figure 1: Block diagram

2 Pinout

2.1 Pin Configuration QFN20L4 / TSSOP16

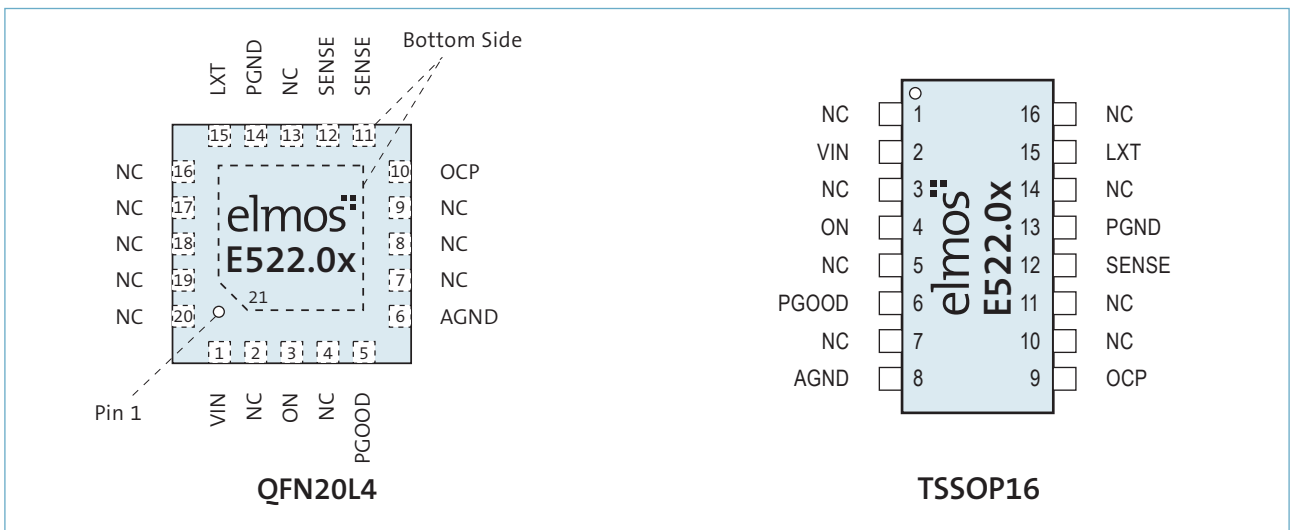

Figure 2: Package pinout, transparent top view, not to scale.

Elmos Semiconductor AG reserves the right to change the detail specifications as may be required to permit improvements in the design of its products.

2.2 Pin Description

Table 1: Pin Description

Pin		Name	Type ¹⁾	Description	Remark
QFN20L4	TSSOP16				
1	2	VIN	HV S	High-Voltage Supply input	bypass to GND with a low ESR capacitance >20µF
2	1	NC	-	Not connected	Open or GND
3	4	ON	HV AI	High-Voltage input to enable converter	
4	3	NC	-	Not connected	Open or GND
5	6	PGOOD	HV AO	High-Voltage capable low-side open-drain output for power good flag	
6	8	AGND	S	Signal ground connection	
7	5	NC	-	Not connected	Open or GND
8	7	NC	-	Not connected	Open or GND
9	10	NC	-	Not connected	Open or GND
10	9	OCP	AI	Over-current protection resistor input, connect to ground via resistor	
11	-	SENSE	AI	Feedback input for converter regulation, connect to output voltage	Redundant, connect both SENSE pins
12	12	SENSE	AI	Feedback input for converter regulation, connect to output voltage	Redundant, connect both SENSE pins
13	11	NC	-	Not connected	Open or GND
14	13	PGND	S	Power ground connection	
15	15	LXT	HV AO	Integrated high-side switch output, connect freewheeling diode and inductor to this pin	
16	14	NC	-	Not connected	Open or GND
17	16	NC	-	Not connected	Open or GND
18	-	NC	-	Not connected	Open or GND
19	-	NC	-	Not connected	Open or GND
20	-	NC	-	Not connected	Open or GND
21	-	EP	-	Exposed die pad	Connect to GND

1) D = Digital, A = Analog, S = Supply, HV = High voltage (see max. ratings), I = Input, O = Output

Note: Pins with identical names have to be connected.

3 Absolute Maximum Ratings

Stresses beyond these absolute maximum ratings listed below may cause permanent damage to the device. These are stress ratings only; operation of the device at these or any other conditions beyond those listed in the operational sections of this document is not implied. Exposure to absolute maximum rated conditions for extended periods may affect device reliability. All voltages referred to V_{GND} . Currents flowing into terminals are positive, those drawn out of a terminal are negative.

Description	Condition	Symbol	Min	Max	Unit
Supply voltage at pin VIN		V_{VIN}	-0.3	40	V
Voltage at pin ON		V_{ON}	-0.3	40	V
Voltage at pin PGOOD		V_{PGOOD}	-0.3	40	V
Current at pin PGOOD		I_{PGOOD}	0	5	mA
Voltage at pin SENSE		V_{SENSE}	-0.3	6	V
Voltage at pin OCP		V_{OCP}	-0.3	0.8	V
Voltage at pin LXT		V_{LXT}	-10	$V_{IN}+0.3$	V
Power dissipation (E522.01-06)		P_{TOT}		500	mW
Power dissipation (E522.07-09)		P_{TOT}		1	W
Storage temperature		T_{STG}	-50	+150	°C

4 ESD Protection

Description	Condition	Symbol	Min	Max	Unit
ESD HBM protection at pin VIN	1)	$V_{ESD(HBM)}$	3		kV
ESD HBM protection at all other pins	1)	$V_{ESD(HBM)}$	2		kV
ESD CDM protection at all pins	2)	$V_{ESD(CDM)}$	500		V
ESD CDM protection at corner pins	2)	$V_{ESD(CDM)C}$	750		V

1) According to AEC-Q100-002 (HBM) chip level test

2) According to AEC-Q100-011 (CDM) chip level test

5 Recommended Operating Conditions

Description	Condition	Symbol	Min	Max	Unit
Junction temperature	2)	T_J	-40	+150	°C
Ambient temperature		T_{amb}	-40	+125	°C
Supply voltage at pin VIN		V_{VIN}	4.5 ¹⁾	40	V

1) For $V_{VIN} < V_{OUT}$, E522.0x enters 100% duty cycle mode

2) For junction temperatures > 150°C thermal shutdown may occur

6 Electrical Characteristics

($V_{VIN} = 4.5V$ to $40V$, $T_{amb} = -40^{\circ}C$ to $+125^{\circ}C$, unless otherwise noted. Typical values are at $V_{VIN} = 14V$ and $T_{amb} = +25^{\circ}C$. Positive currents flow into the device pins.)

Description	Condition	Symbol	Min	Typ	Max	Unit
Supply						
Sleep mode quiescent current	$V_{ON} = 0$; non-switching	$I_{VIN,q,SLP}$		8		μA
Active mode quiescent current	$V_{ON} = V_{VIN} > 8V$; $I_{OUT} < 100\mu A$	$I_{VIN,q}$		12		μA
Active mode quiescent current	$V_{ON} = V_{VIN}$ L_{XT} driver OFF	$I_{VIN,q}$		150		μA
Input resistance at pin ON	$V_{ON} = V_{VIN} = 14V$	I_{ON}		7		$M\Omega$
Threshold voltage at pin ON	$V_{VIN} > 4.5V$	$V_{ON,th}$	1.40	1.48	1.56	V
VIN Undervoltage Lockout	V_{VIN} rising	$V_{VIN,UV}$		3.5	4.2	V
Output Current Limit Programming						
Output voltage at OCP	$24k\Omega \leq R_{OCP} \leq 60k\Omega$	V_{OCP}		500		mV
OCP Selection Resistor		R_{OCP}	24		60	$k\Omega$
Load capacitance at OCP		C_{OCP}			100	pF
E522.01 Output						
Output regulation threshold ¹⁾	$I_{OUT} = 500mA$ $V_{VIN} = 14V$	V_{OUT}	4.8	5.0	5.2	V
On Resistance at LXT	$V_{VIN} = 14V$	$R_{DS(ON)}$		0.7	1.5	Ω
Over-current detection	$R_{OCP} = 24k\Omega$ ²⁾	$I_{OCP,24k\Omega}$	740	830	920	mA
	$R_{OCP} = 60k\Omega$ ²⁾	$I_{OCP,60k\Omega}$	300	350	400	mA
E522.02 Output						
Output regulation threshold ¹⁾	$I_{OUT} = 500mA$ $V_{VIN} = 14V$	V_{OUT}	3.2	3.33	3.46	V
On Resistance at LXT	$V_{VIN} = 14V$	$R_{DS(ON)}$		0.7	1.5	Ω
Overcurrent detection	$R_{OCP} = 24k\Omega$ ²⁾	$I_{OCP,24k\Omega}$	740	830	920	mA
	$R_{OCP} = 60k\Omega$ ²⁾	$I_{OCP,60k\Omega}$	300	350	400	mA
E522.03 Output						
Output regulation threshold ¹⁾	$I_{OUT} = 350mA$ $V_{VIN} = 14V$	V_{OUT}	4.8	5.0	5.2	V
On Resistance at LXT	$V_{VIN} = 14V$	$R_{DS(ON)}$		1.1	2.5	Ω
Overcurrent detection	$R_{OCP} = 24k\Omega$ ²⁾	$I_{OCP,24k\Omega}$	490	550	610	mA
	$R_{OCP} = 60k\Omega$ ²⁾	$I_{OCP,60k\Omega}$	190	230	270	mA
E522.04 Output						
Output regulation threshold ¹⁾	$I_{OUT} = 350mA$ $V_{VIN} = 14V$	V_{OUT}	3.2	3.33	3.46	V
On Resistance at LXT	$V_{VIN} = 14V$	$R_{DS(ON)}$		1.1	2.5	Ω
Overcurrent detection	$R_{OCP} = 24k\Omega$ ²⁾	$I_{OCP,24k\Omega}$	490	550	610	mA
	$R_{OCP} = 60k\Omega$ ²⁾	$I_{OCP,60k\Omega}$	190	230	270	mA

1) Given value is switching threshold at pin SENSE, for $V_{VIN} < V_{OUT}$ regulator provides 100% conductance mode

2) Measured at $V_{VIN} = 14V$

Elmos Semiconductor AG reserves the right to change the detail specifications as may be required to permit improvements in the design of its products.

Electrical Characteristics (continued)

($V_{VIN} = 4.5V$ to $40V$, $T_{amb} = -40^{\circ}C$ to $+125^{\circ}C$, unless otherwise noted. Typical values are at $V_{VIN} = 14V$ and $T_{amb} = +25^{\circ}C$. Positive currents flow into the device pins.)

Description	Condition	Symbol	Min	Typ	Max	Unit
E522.05 Output						
Output regulation threshold ¹⁾	$I_{OUT} = 500mA$ $V_{VIN} = 14V$	V_{SENSE}	1.416	1.475	1.534	V
On Resistance at LXT	$V_{VIN} = 14V$	$R_{DS(ON)}$		0.7	1.5	Ω
Over-current detection	$R_{OCP} = 24k\Omega$ ²⁾	$I_{OCP,24k\Omega}$	740	830	920	mA
	$R_{OCP} = 60k\Omega$ ²⁾	$I_{OCP,60k\Omega}$	300	350	400	mA
E522.06 Output						
Output regulation threshold ¹⁾	$I_{OUT} = 350mA$ $V_{VIN} = 14V$	V_{SENSE}	1.416	1.475	1.534	V
On Resistance at LXT	$V_{VIN} = 14V$	$R_{DS(ON)}$		1.1	2.5	Ω
Overcurrent detection	$R_{OCP} = 24k\Omega$ ²⁾	$I_{OCP,24k\Omega}$	490	550	610	mA
	$R_{OCP} = 60k\Omega$ ²⁾	$I_{OCP,60k\Omega}$	190	230	270	mA
E522.07 Output						
Output regulation threshold ¹⁾	$I_{OUT} = 1A$ $V_{VIN} = 14V$	V_{OUT}	4.8	5.00	5.2	V
On Resistance at LXT	$V_{VIN} = 14V$	$R_{DS(ON)}$		0.44	0.75	Ω
Over-current detection	$R_{OCP} = 24k\Omega$ ²⁾	$I_{OCP,24k\Omega}$	1.3	1.45	1.6	A
	$R_{OCP} = 60k\Omega$ ²⁾	$I_{OCP,60k\Omega}$	0.5	0.6	0.7	A
E522.08 Output						
Output regulation threshold ¹⁾	$I_{OUT} = 1A$ $V_{VIN} = 14V$	V_{OUT}	3.2	3.33	3.46	V
On Resistance at LXT	$V_{VIN} = 14V$	$R_{DS(ON)}$		0.44	0.75	Ω
Overcurrent detection	$R_{OCP} = 24k\Omega$ ²⁾	$I_{OCP,24k\Omega}$	1.3	1.45	1.6	A
	$R_{OCP} = 60k\Omega$ ²⁾	$I_{OCP,60k\Omega}$	0.5	0.6	0.7	A
E522.09 Output						
Output regulation threshold ¹⁾	$I_{OUT} = 1A$ $V_{VIN} = 14V$	V_{SENSE}	1.416	1.475	1.534	V
On Resistance at LXT	$V_{VIN} = 14V$	$R_{DS(ON)}$		0.44	0.75	Ω
Overcurrent detection	$R_{OCP} = 24k\Omega$ ²⁾	$I_{OCP,24k\Omega}$	1.3	1.45	1.6	A
	$R_{OCP} = 60k\Omega$ ²⁾	$I_{OCP,60k\Omega}$	0.5	0.6	0.7	A

1) Given value is switching threshold at pin SENSE, for $V_{VIN} < V_{SENSE}$ regulator provides 100% conduction mode

2) Measured at $V_{VIN} = 14V$

Electrical Characteristics (continued)

($V_{VIN} = 4.5V$ to $40V$, $T_{amb} = -40^{\circ}C$ to $+125^{\circ}C$, unless otherwise noted. Typical values are at $V_{VIN} = 14V$ and $T_{amb} = +25^{\circ}C$. Positive currents flow into the device pins.)

Description	Condition	Symbol	Min	Typ	Max	Unit
Switching						
Switching frequency		f_s	0		1.75	MHz
Minimum LXT on time	$I_{OUT} < I_{OCP}$	$t_{LXT(ON)}$		260		ns
	$I_{OUT} \geq I_{OCP}$	$t_{LXT(ON)}$		100		ns
Minimum LXT off time	PGOOD = '1'	$t_{LXT(OFF)}$		520		ns
	$I_{OUT} \geq I_{OCP}$, $V_{SENSE} > 1.2V$	$t_{LXT(OFF)}$		1330		ns
	$I_{OUT} \geq I_{OCP}$, $V_{SENSE} < 1.0V$	$t_{LXT(OFF)}$		2450		ns
Power Good Detector						
Power good detection threshold, rising edge		$V_{SENSE,th(LH)}/V_{OUT(NOM)}$		92.5		%
Power good detection threshold, falling edge		$V_{SENSE,th(HL)}/V_{OUT(NOM)}$		90		%
Output voltage at pin PGOOD	$V_{SENSE} < V_{SENSE,th(HL)}$ $I_{PGOOD} = 2mA$	V_{PGOOD}		0.2	0.4	V
Leakage at pin PGOOD	$V_{SENSE} = V_{OUT,NOM}$ $V_{PGOOD} = 5V$	$I_{PGOOD,lk}$			3	μA
IDLE Detector						
IDLE detection delay	no switching	T_{IDLE}	70	110	150	μs
Average LXT duty cycle for IDLE	Discontinuous operation	D_{IDLE}		1.38		%
Wake-up threshold during IDLE	relative to nominal V_{OUT} in %	$V_{SENSE,WU}$		95		%
Wake-up delay after IDLE	$V_{SENSE} < V_{SENSE,WU}$	$T_{DELACTIVE}$		10	25	μs

7 Typical Operating Characteristics

Diagrams showing typical characteristics at $V_{VIN}=14V$ and $T_{AMB}=25^{\circ}$, unless otherwise noted

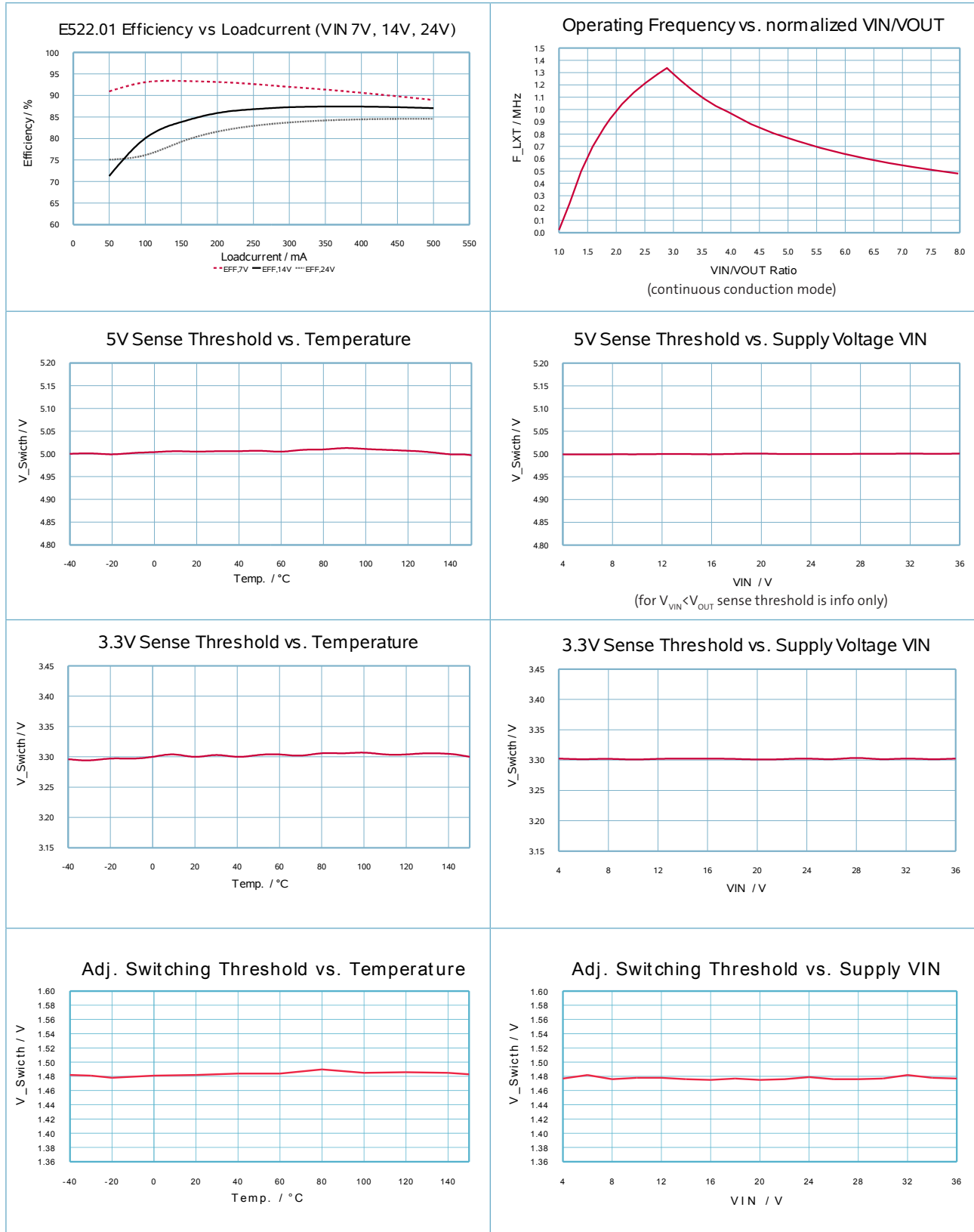

Elmos Semiconductor AG reserves the right to change the detail specifications as may be required to permit improvements in the design of its products.

LOW QUIESCENT CURRENT STEP DOWN CONVERTER FAMILY

PRODUCTION DATA - AUG 13, 2015

E522.01, E522.02, E522.03, E522.04, E522.05, E522.06, E522.07, E522.08, E522.09



Elmos Semiconductor AG reserves the right to change the detail specifications as may be required to permit improvements in the design of its products.

LOW QUIESCENT CURRENT STEP DOWN CONVERTER FAMILY

PRODUCTION DATA - AUG 13, 2015

E522.01, E522.02, E522.03, E522.04, E522.05, E522.06, E522.07, E522.08, E522.09

Internal FET On-Resistance vs. Temperature

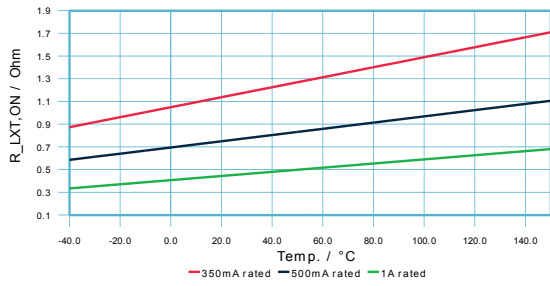

Propagation Delay Sense to LXT vs VIN Voltage

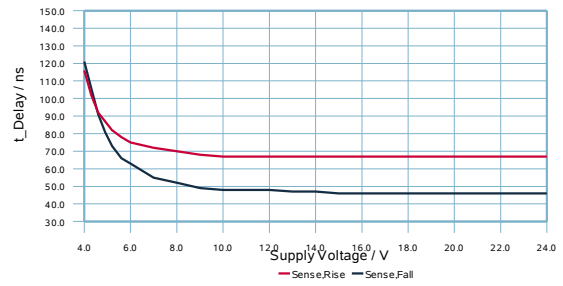

Typ. VIN Undervoltage Lockout (vs. Temperature)

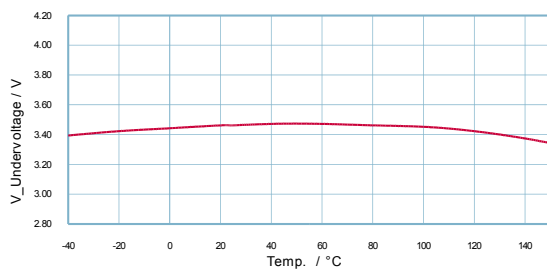

Enable Threshold at ON vs Temperature

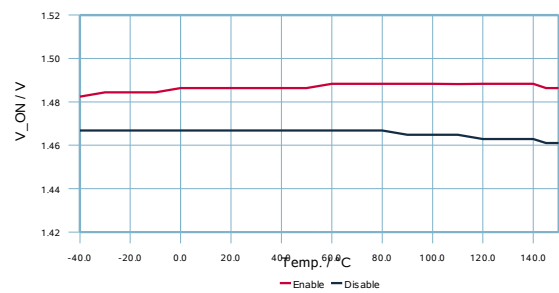

ON Pulldown Resistance vs ON Voltage

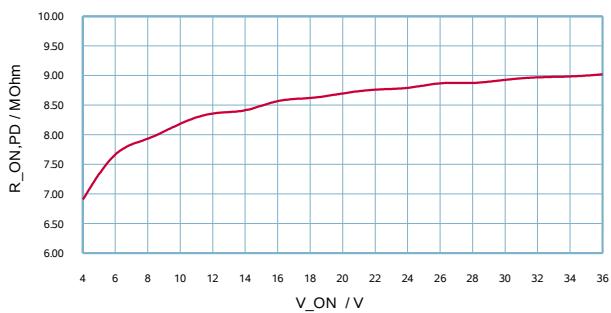

Elmos Semiconductor AG reserves the right to change the detail specifications as may be required to permit improvements in the design of its products.

8 Functional Description

8.1 General Description

E522.0x product family is a fixed output voltage step-down converter family intended for current-sensitive automotive and general battery driven applications, featuring open loop stability and short current limitation for the integrated driver transistor. High operating frequency allows the use of small-sized external components. Integrated IDLE detection provides very low standby currents, significantly reducing the applications total current consumption. If the application supplied by E522.0x is set into low-current mode (typ. << 1mA, see 8.3), current consumption at VIN is adapted to typical 12µA only.

The pulse frequency modulation (PFM) scheme does not need a clock signal for operation, providing minimum ON/OFF time regulation for the internal switch. Furthermore, the PFM scheme allows fastest transient line and load responses without the need for external compensation networks. Adjustable internal current measurement allows optimal adaption to the inductor without the need for a shunt resistor.

Pin ON	Load condition	Load condition	Internal Signal "IDLE"	Mode	V _{OUT}	I _{VIN}
$V_{ON} < V_{ON,TH}$				SLEEP	0V	8µA
$V_{ON} > V_{ON,TH}$	Nominal load	$D > D_{IDLE}$	"0"	NORMAL	V _{OUT,nom}	150µA
$V_{ON} > V_{ON,TH}$	Reduced load << 1mA	$D < D_{IDLE}$	"1"	IDLE	V _{OUT,nom} - (0%... -5%)	12µA

8.2 Pulse Frequency Modulated Converter

The LXT switch control signal is based on a combination of output voltage V_{SENSE}, input voltage V_{VIN} and measured switch current. It provides adaptive frequency in the range of 0Hz up to typ. 1.33MHz as seen in typical performance figures.

To avoid unnecessary switching, a minimum ON time of typ. 260ns and OFF time of 520ns is used. ON time will be reduced below 260ns if over-current is detected. OFF time will automatically be increased in length to limit current flow during start-up or short circuit to GND at pin LXT or VOUT.

The figure below shows the typical normalized operating frequency in continuous conduction mode:

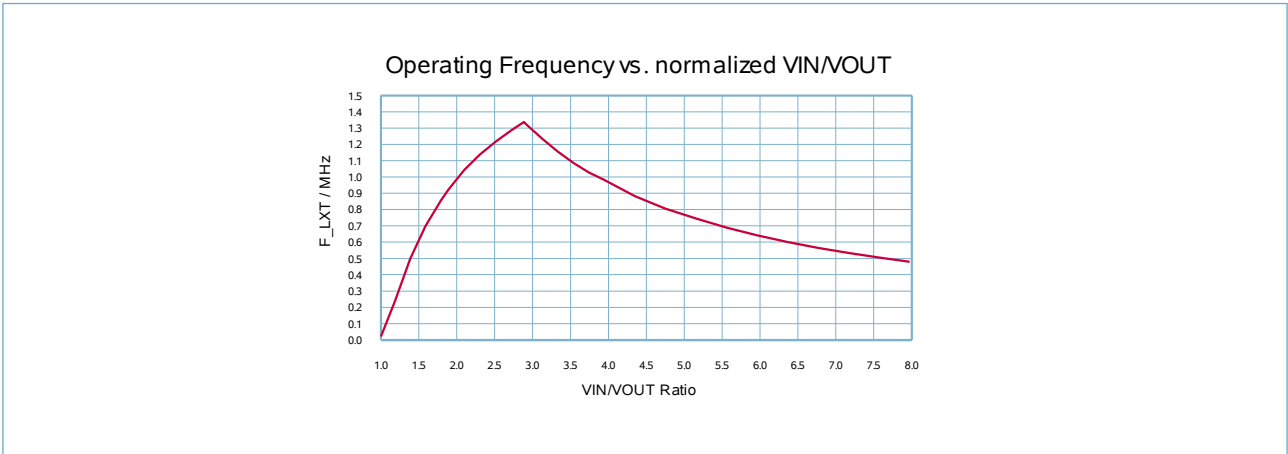

Figure 3: Operating Frequency vs normalized VIN/VOUT Ratio

8.3 Idle Detection

Idle operation basically is a sequence of standby periods followed by recharge cycles. During IDLE the application is supplied by the output capacitance. The reference is switched to typ. 95% of nominal value, at which the converter will be reactivated to high power operation. In this way, light load currents are compressed to short recharge phases, during which a high efficiency can be reached.

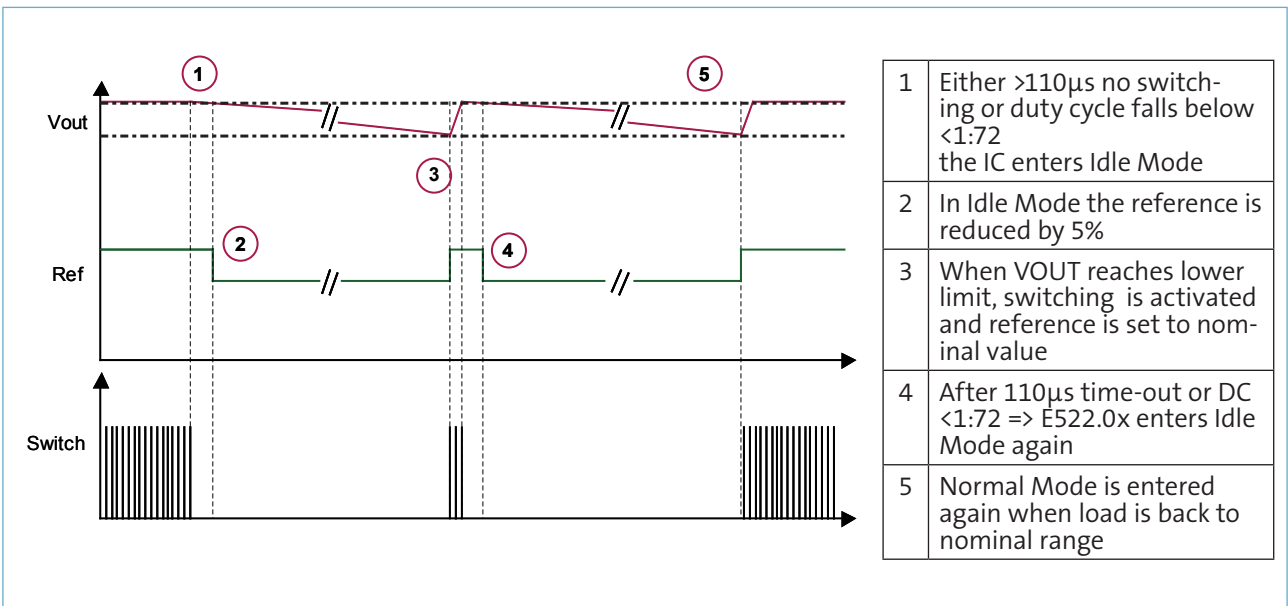

Figure 4: Behaviour in IDLE Mode

E522.0x automatically switches between IDLE and ACTIVE if no external load is applied to E522.0x. The criterion for the decision is that either no switching activity occurred for longer than typ. 110µs or the duty cycle of the converter falls below a limit of typically 1:72. (see figure 4)

9 Typical Operating Circuit

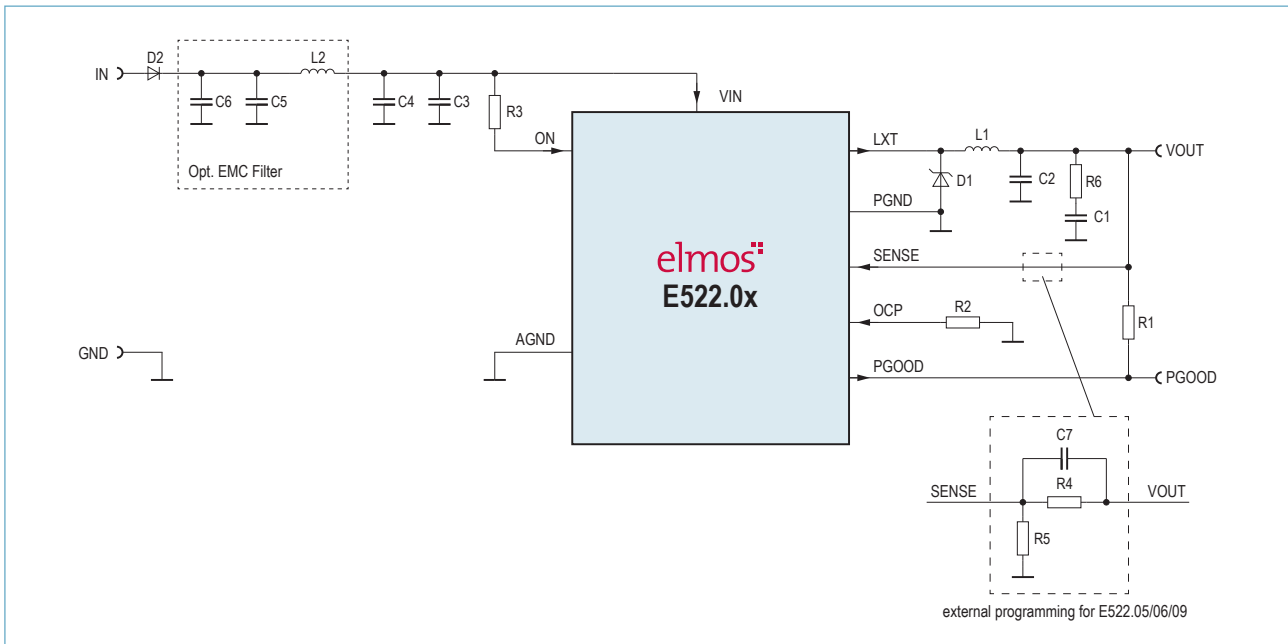

Figure 5: Typical operating circuit diagram

Table 2: External Components

Symbol	Min	Typ	Max	Unit	Description
R1		3.3		kΩ	Pull up resistor for PGOOD
R2	24		60	kΩ	OCP configuration resistor
R3		3.3		kΩ	Optional resistor for connection L to VIN
R4		30 ¹⁾		kΩ	Resistor for output voltage programming
R5		30		kΩ	Resistor for output voltage programming
R6		0.2		Ω	Optional ESR-equivalent resistor
C1	47	100		μF	Output filter capacitor, low ESR
C2		33	100	nF	Output filter capacitor, low ESR, low ESL type
C3	20	33		μF	Input filter capacitor
C4		220		nF	Input filter capacitor, low ESR, low ESL type
C5		100		nF	EMC capacitor; low ESR, low ESL type
C6		1		nF	EMC capacitor; low ESR, low ESL type
C7					Optional AC-coupling capacitor (see chapter 9.2.5)
L1	18	33	82	μH	Inductor L _{LXT} @ E522.01-06
L1	10	22	82	μH	Inductor L _{LXT} @ E522.07-09
L2					EMC ferrite e.g. Würth 742-792-118
D1					Freewheeling diode for LXT, preferred Vishay SS14
D2					Optional reverse polarity protection diode

1) Select for V_{OUT} according to
$$R_4 = R_5 \cdot \left(\frac{V_{OUT} - V_{SENSE}}{V_{SENSE}} \right)$$

Elmos Semiconductor AG reserves the right to change the detail specifications as may be required to permit improvements in the design of its products.

9.2 Application / Implementation Hints

The following chapter will give additional recommendations and advices for the implementation of E522.0x, giving starting values for components during prototyping.

9.2.1 Maximum Input Voltage in case of adjustable output voltage (E522.05/06/09)

The maximum input voltage is defined by the minimum $T_{ON,MIN}$ (during over-current limitation) and the requested output voltage. The following diagram shows the recommended area for the input voltage. If the input voltage is higher than recommended, due to transient effects the maximum current in the inductor may exceed the configured over-current limitation during start-up or in case of short circuit.

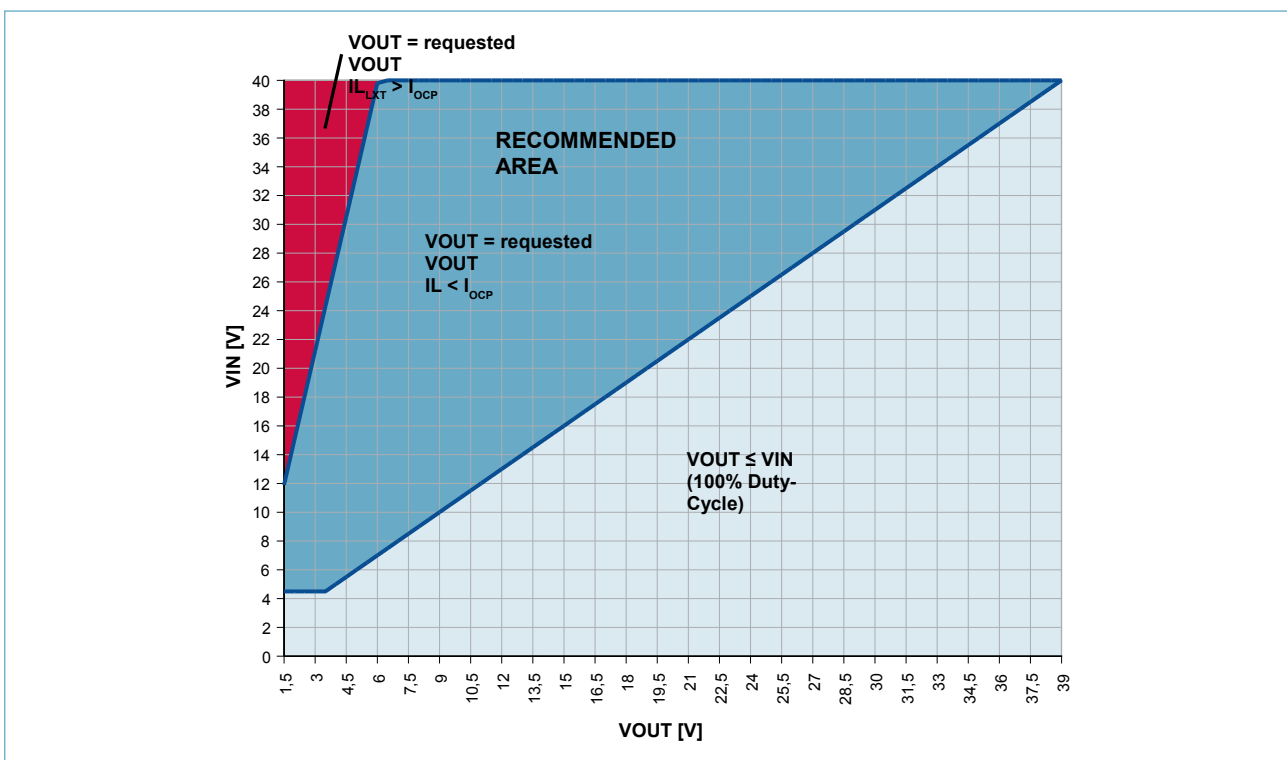

Figure 6: Maximum recommended VIN

9.2.2 Maximum output current E522.05/06/09

E522.0x limits the inductor peak current. Lower end of inductor ripple current depends on $T_{OFF,MIN}$, the inductance value and the output voltage. The maximum available output current is less or equal to the average current flowing in the inductance.

The following graph visualizes the relation between these parameters.

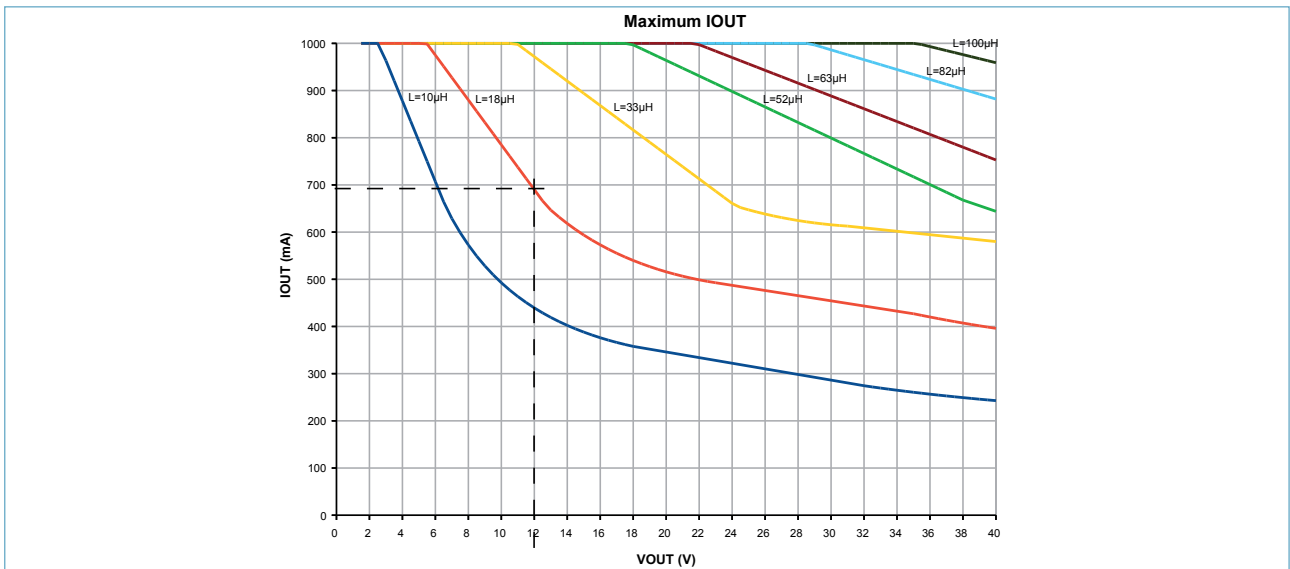

Figure 7: Maximum Output Current vs. Output Voltage (1A / E522.09)

For example, with an inductor of 18µH and an output voltage of 12V, the minimum available output current is 690mA.

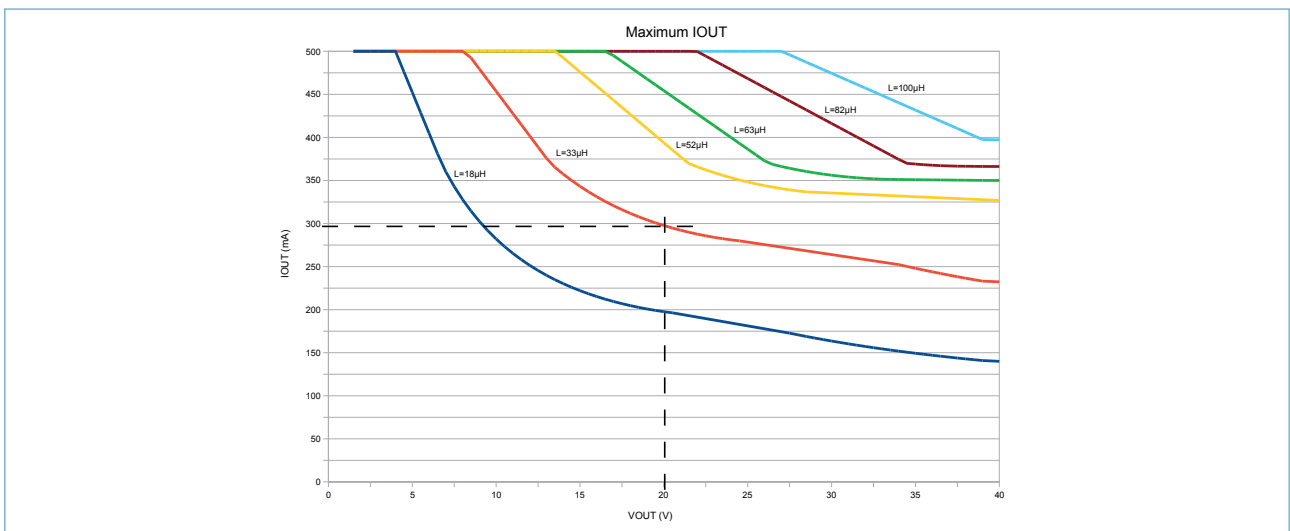

Figure 8: Maximum Output Current vs. Output Voltage (500mA / E522.05)

For example, with an inductor of 33µH and an output voltage of 20V, the minimum available output current is 295mA.

Elmos Semiconductor AG reserves the right to change the detail specifications as may be required to permit improvements in the design of its products.

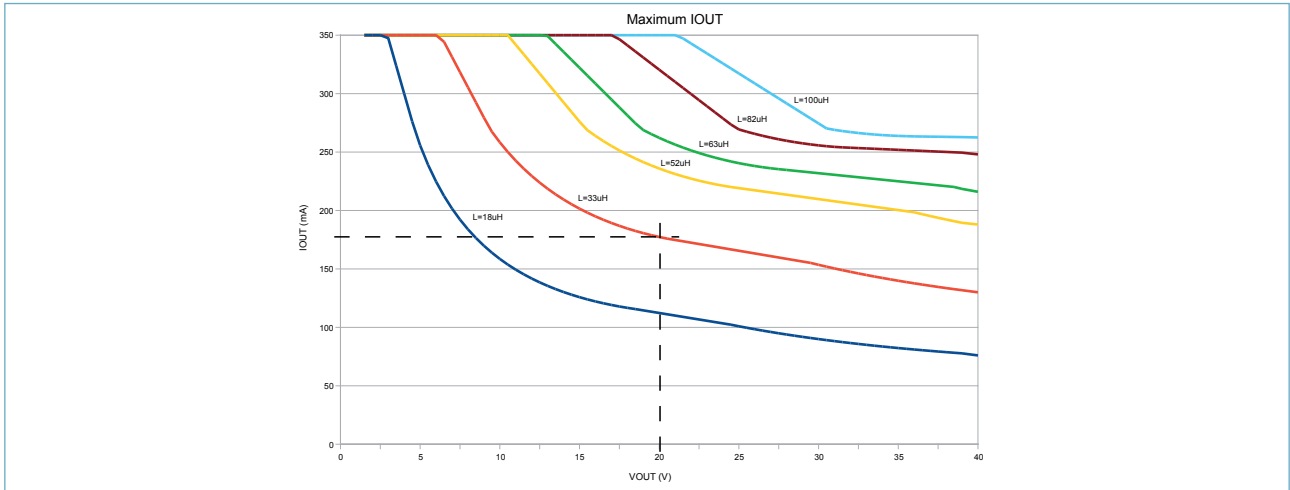

Figure 8: Maximum Output Current vs. Output Voltage (350mA / E522.06)

For example, with an inductor of 33µH and an output voltage of 20V, the minimum available output current is 175mA.

9.2.3 L_{LXT} Inductor Selection

For a given application (in continuous conducting mode), it is either recommended to choose an inductance value that is suitable for ±15% current ripple at the typical operating frequency or to use the following equations. Depending on V_{VIN} to V_{OUT} ratio, usually two equations describe the maximum peak-to-peak current ripple in the inductor L_{LXT}. It can either be calculated from the maximum input voltage at VIN (V_{VIN,MAX,APP})

$$a) \quad I_{RIPPLE, LXT, PP1} = \frac{T_{ON, MIN} \cdot (V_{VIN, MAX, APP} - V_{OUT, NOM})}{L_{LXT}}$$

or by the following equation (with V_{DIODE} being the forward voltage drop of the free-wheeling diode)

$$b) \quad I_{RIPPLE, LXT, PP2} = \frac{T_{OFF, MIN, NOM} \cdot (V_{OUT, NOM} + V_{DIODE})}{L_{LXT}}$$

Take the higher result of both equations into account during choice of the external capacitors ESR (see chapter 9.2.4). The minimum ripple may either occur at the maximum operation frequency or at the lowest input voltage that is required for the application. In most cases, the current ripple at peak-operating-frequency can also be calculated by equation b) above.

To choose a sufficiently high saturation current for the inductor L_{LXT}, consider

- the maximum application load current plus half of the maximum ripple current calculated above and
- the configured current limitation derived from R_{OCP} (to avoid degradation or other effects due to saturation of the inductor core - depending on the magnetic core material)

In general an additional saturation margin of >25% for the inductor current rating is recommended for transient effects, especially at extreme V_{VIN} to V_{OUT} voltage ratios.

DC resistance of L_{LXT} (referred here as R_{LXT,DC}) reduces efficiency and contributes to the losses in the inductor (combined with AC losses which may arise due the use of high frequency operation). A DC resistance <0.5Ω is recommended for E522.01-06 (<0.25Ω for E522.07-09). At a given load current I_{LOAD}, resistance affects minimum input voltage required to regulate V_{OUT} in the following way

$$V_{IN, MIN} = V_{OUT, NOM} + I_{LOAD} \cdot (R_{DS(ON)} + R_{LXT, DC})$$

Elmos Semiconductor AG reserves the right to change the detail specifications as may be required to permit improvements in the design of its products.

9.2.4 C_{OUT} Capacitor Selection

During nominal operation electrical serial resistance (ESR) of the capacitor is important to generate a minimum output voltage ripple of 10mV to 100mV. This ripple is necessary to provide a proper regulation information for E522.0x. It depends on peripheral elements chosen (L_{LXT} and C_{OUT}) and their parasitic behaviour as explained further on.

The ESR of the capacitor C_{OUT} (named R_{ESR,COUT}, see operating circuit R6) must be high enough to ensure a voltage ripple for V_{OUT} to provide high-frequency switching. The ripple voltage can basically be calculated using the inductor current ripple (see chapter 9.2.3) by

$$V_{RIPPLE,OUT} = R_{ESR,COUT} \cdot I_{RIPPLE,LXT,PP}$$

Electrical serial inductance should be kept as low as possible, what can be achieved by placing a parallel ceramic type capacitor of <100nF (typ. 33nF).

During IDLE, the application is supplied by the output capacitor C_{OUT}. The capacitance, which is necessary to power the application until E522.0x fully wakes up, can be calculated using the maximum load current step (I_{LOAD,MAX}) and a maximum tolerable voltage drop (U_{DROP,MAX}) in the following way:

$$C_{OUT} = \frac{I_{LOAD,MAX} \cdot 25\mu s}{U_{DROP,MAX} - R_{ESR,COUT} \cdot I_{LOAD,MAX}}$$

For example, assuming a maximum load step of 350mA, a tolerable voltage drop of 120mV and R_{ESR,COUT} being 120mΩ the output capacitance should be chosen >112μF. For proper active operation, it is necessary to choose capacitance values >22μF at V_{OUT}.

Take into account, that many capacitor types show a strong temperature and voltage dependency, or may be sensible to high peak currents. Make sure, that at extreme temperatures and voltages the capacitance value is reached. For automotive environments capacitors of X7R material (or better) may be necessary.

9.2.5 R_{SENSE1}, C_{SENSE} Selection for adjustable E522.05/06/09

The resistors R_{SENSE1} and R_{SENSE2} have to be chosen high enough to avoid a reduction of the efficiency. A typical current of 50 μA is recommended to avoid sensitivity to noise. The capacitor C_{SENSE} helps to produce a correct ripple voltage at SENSE pin. Without enough ripple at SENSE pin, the regulation will not be optimal and you could observe burst pulses at LXT pin. When the ripple voltage is high enough, you should see a stable operating frequency. To choose C_{SENSE} start without any capacitor and increase the value until you are satisfied with the regulation.

9.2.6 Rectification- / Freewheeling Diode Selection

The free-wheeling diode must have a low forward voltage (to increase efficiency) as well as a very low reverse recovery time of typically 10ns. In general, a fast Schottky type diode is recommended. High parasitic capacitance as well as long reverse recovery time may cause additional radiated emission at LXT. Parasitic capacitance of this diode decreases the overall efficiency and causes current spikes when the LXT driver turns on.

During IDLE, consider the leakage of the free-wheeling diode at nominal converter output voltage which will contribute to the overall current consumption (see IDLE adaption, chapter 9.2.9). In general, a bipolar diode can provide lower leakage current and parasitic capacitance, but may also have a negative impact on efficiency due to higher forward voltage drop. Reverse recovery time of the diode must be taken into account.

Elmos Semiconductor AG reserves the right to change the detail specifications as may be required to permit improvements in the design of its products.

9.2.7 Over-Current Configuration at OCP

To adjust the internal over-current limitation of the LXT high-side driver to a value of I_{LIM} , the resistor between OCP and GND can be chosen by interpolation between the specified values (in the range of 24kΩ to 60kΩ) by

$$R_{OCP} = \frac{I_{OCP,24k\Omega}}{I_{LIM}} \cdot 24k\Omega \quad | \quad I_{LIM} \leq I_{OCP,24k\Omega}$$

Choice the current I_{LIM} with respect to the maximum usable current of the inductor L_{LXT} . Capacitive load at pin OCP has to be avoided due to stability reasons. It must not exceed 100pF.

9.2.8 VIN Capacitor Selection

VIN input capacitance value can be chosen from an acceptable voltage ripple $V_{VIN,RIPPLE,MAX}$ (defined by the overall application requirements) together with I_{LIM} (configured by R_{OCP}) and the ESR of VIN capacitor by

$$C_{VIN} = \frac{(I_{LIM} \cdot t_{ON,MIN})}{(V_{VIN,RIPPLE,MAX} - I_{LIM} \cdot R_{ESR,C_{VIN}})}$$

Both, the result of above equation, but also a minimum of 22μF are to be taken into account. Additionally, a parallel low ESR and low ESL ceramic capacitor type has to be placed (typ. 220nF).

Considerations regarding temperature and voltage dependency apply to VIN capacitors as well (see chapter 9.2.4), especially voltage dependency.

9.2.9 Idle Adaption Options

IDLE / ACTIVE state detection can be adapted to a given application by consideration of the following external influences:

a) During start-up, the energy within the inductor (approximately $0.5 \times L_{LXT} \times I_{LIM}^2$) has to be consumed by the load within the IDLE detection time-out (to stay in ACTIVE mode). It is proportional to the inductance L_{LXT} and to the square of configured OCP current limit.

b) At nominal operation, the power which is transferred to the output in discontinuous operation depends on the inductance at L_{LXT} , the current which is build up during $T_{ON,MIN}$ and the duty-cycle IDLE condition.

This detection mechanism allows to shift the detection threshold proportional to $1/L_{LXT}$. Note, that the output power in this case also depends on the square of charging voltage $V_{VIN-VOUT}$, which may require to adapt L_{LXT} to the typical application input voltage.

c) In general, cross-coupling between high voltage switching of LXT and input SENSE is to be avoided. In case that practically it may not be completely avoidable, a third effect based on the amount of coupling must be considered. Distortions can lead to self-excitation of the regulator, charging the output until the lower end of the output voltage ripple crosses the regulation point. The average of the output voltage ripple (1/2 for triangular ripple) has to be discharged by the load before a time-out is detected (typ. 110μs - to stay in ACTIVE mode).

Depending on choice of external components, the rectification / free-wheeling diode leakage current has to be taken into account, because it poses a load to E522.0x, too. If it generates sufficient switching activity to trigger the duty cycle IDLE condition, the converter will provide nominal output voltage.

Elmos Semiconductor AG reserves the right to change the detail specifications as may be required to permit improvements in the design of its products.

Consider the leakage current of the free-wheeling diode for a reverse voltage of V_{OUT} and the maximum ambient temperature. The above described measures a,b,c (in most cases choice of inductance L_{LXT}) can be used to adapt the applications dimensioning to this additional load.

9.2.10 Misc Application Remarks

Optional, regarding VIN voltage supervision, the accurate threshold at pin ON can be used to implement under-voltage lock-out for the converter, automatically switching to sleep mode if necessary. In such cases a resistive divider between VIN and GND, connected to ON can be used. The threshold is defined by

$$V_{VIN,MIN} = V_{ON,TH} \cdot \left(1 + \frac{R2}{R1}\right)$$

Choose the divider impedance significantly lower than the typical input impedance of 7MΩ at pin ON to avoid inaccuracy. Note, that the divider current directly contributes to the application current consumption.

For reverse polarity protection a diode (or comparable reverse voltage protection measure) for VIN is recommended. In EMC sensitive environments additional decoupling measures at VIN are recommended.

10 Product Ordering Information

Product	V _{OUT}			I _{OUT}			Package		Wettable flanks		Order. No.:
	5V	3.3V	1.5 to 40V	1000mA	500mA	350mA	QFN20L4	TSSOP16	Yes	No	
E522.01	●				●		●			●	E52201A52C
	●				●		●		●		E52201A52CXX2
	●				●			●		●	E52201A65B
E522.02		●			●		●			●	E52202A52C
		●			●		●		●		E52202A52CXX2
		●			●			●		●	E52202A65B
E522.03	●					●	●			●	E52203A52C
	●					●	●		●		E52203A52CXX2
	●					●		●		●	E52203A65B
E522.04		●				●	●			●	E52204A52C
		●				●	●		●		E52204A52CXX2
		●				●		●		●	E52204A65B
E522.05			●		●		●			●	E52205A52C
			●		●		●		●		E52205A52CXX2
			●		●			●		●	E52205A65B
E522.06			●			●	●			●	E52206A52C
			●			●	●		●		E52206A52CXX2
			●			●		●		●	E52206A65B
E522.07	●			●			●			●	E52207A52C
	●			●			●		●		E52207A52CXX2
E522.08		●		●			●			●	E52208A52C
		●		●			●		●		E52208A52CXX2
E522.09			●	●			●			●	E52209A52C
			●	●			●		●		E52209A52CXX2

Elmos Semiconductor AG reserves the right to change the detail specifications as may be required to permit improvements in the design of its products.

11 Package Reference

11.1 Package Reference QFN20L4

The E522.0x family members are available in a Pb free, RoHS compliant, QFN20L4 plastic package. For dimension details refer to JEDEC MO-220 VGGD-5.

The package is classified to Moisture Sensitivity Level 3 (MSL 3) according to JEDEC J-STD-020C.

It has been qualified according to IEC 86 part 2-20 for the following soldering profile:

1. (200±5) °C, dwell time (50±5) s
2. (260±5) °C, dwell time <10 s

11.2 Package Reference TSSOP16

The E522.0x family members are available in a Pb free, RoHS compliant, TSSOP16 plastic package. For dimension details refer to JEDEC MO-153 AB.

The package is classified to Moisture Sensitivity Level 3 (MSL 3) according to JEDEC J-STD-020C.

It has been qualified according to IEC 86 part 2-20 for the following soldering profile:

1. (200±5) °C, dwell time (50±5) s
2. (260±5) °C, dwell time <10 s

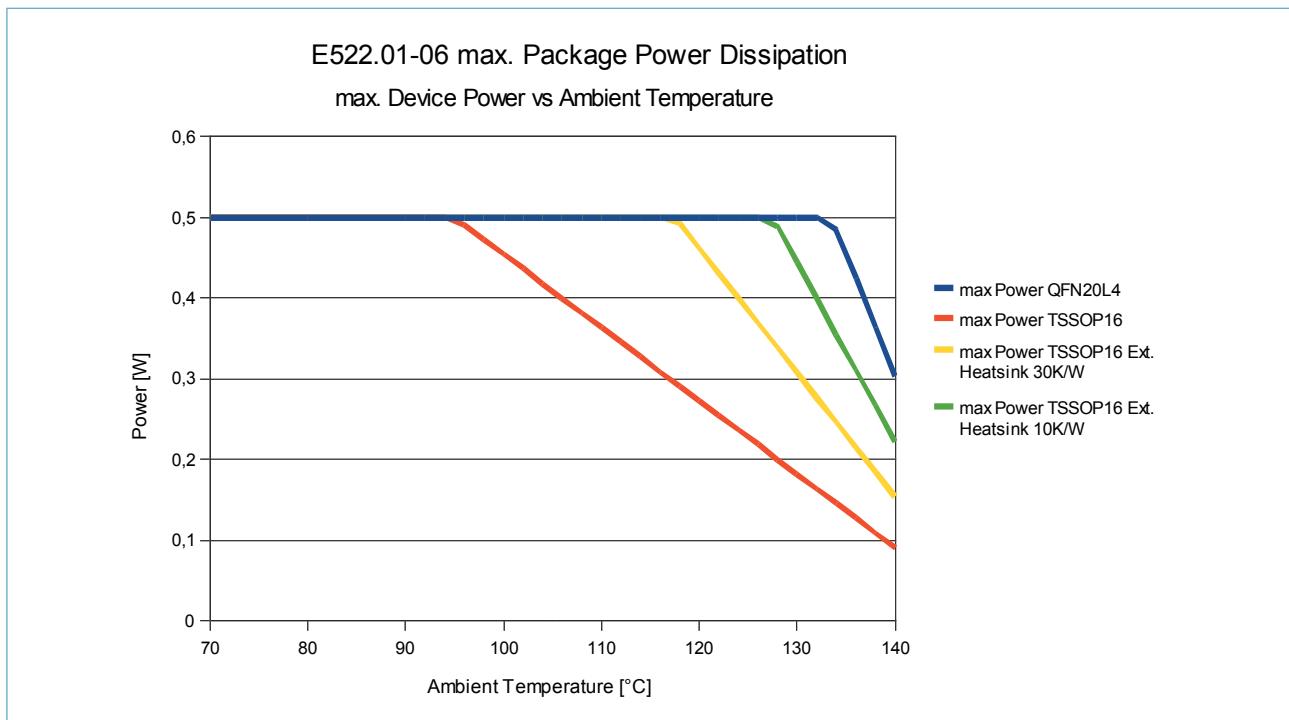

Figure 9: Package power dissipation E522.01-06

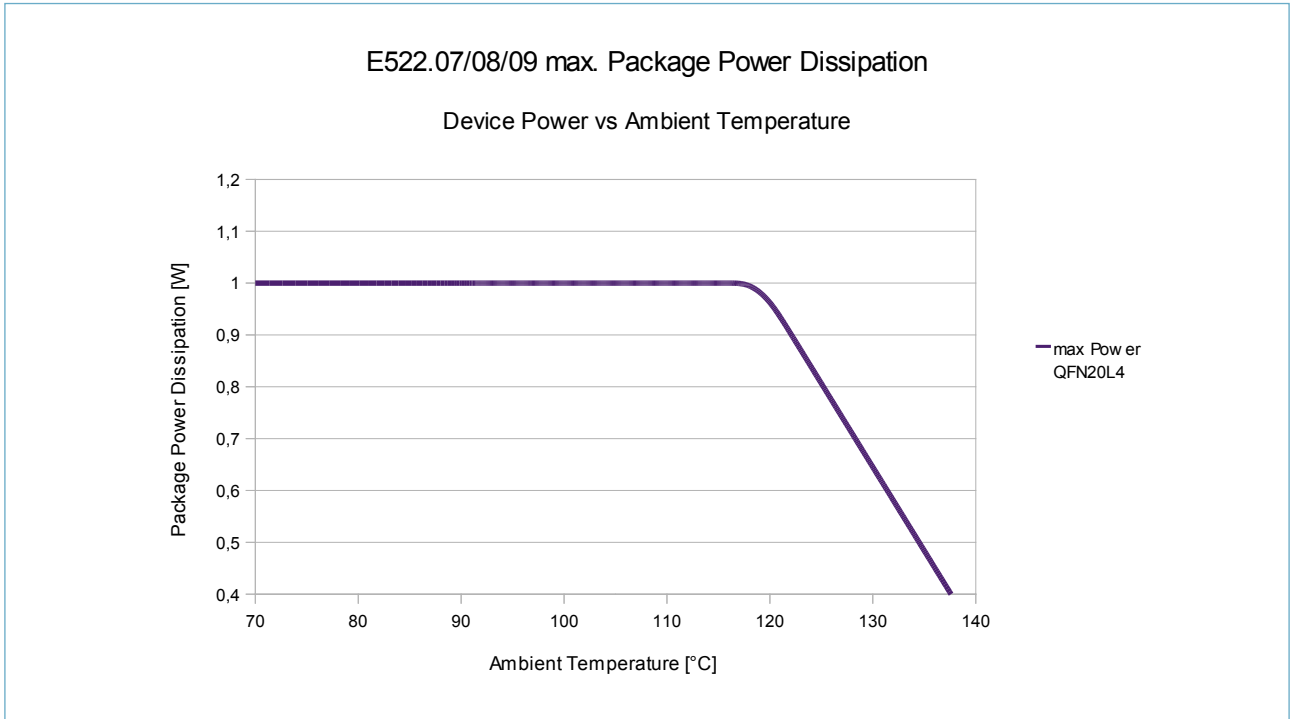

Figure 10: Package power dissipation E522.07-09

11.3 Package Marking for QFN and TSSOP Packages (Top Side)

- ▶ Elmos (Letter)
- ▶ 52201
- ▶ XXXSL
- ▶ YWWR@

Signature	Explanation
52201	Elmos project number
A	Elmos project revision code
XXX	Production lot number
S	Assembler code
YWW	Year and week of assembly
R	Mask revision code
@	Elmos internal code

Elmos Semiconductor AG reserves the right to change the detail specifications as may be required to permit improvements in the design of its products.

11.4 Package Outline QFN20L4

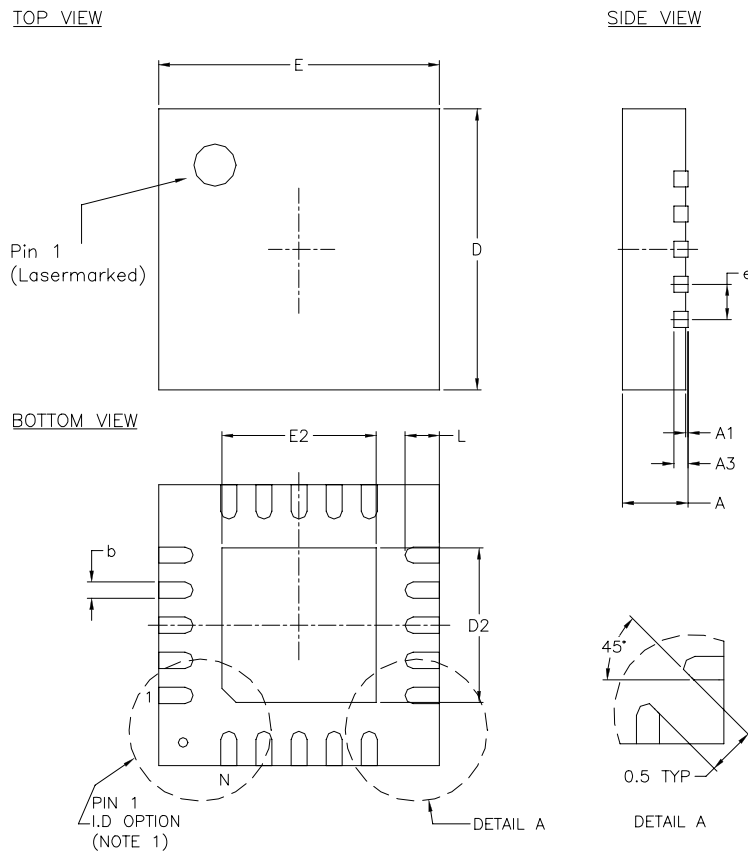

Description	Symbol	mm			inch		
		min	typ	max	min	typ	max
Package height	A	0.80	0.90	1.00	0.031	0.035	0.039
Stand off	A1	0.00	0.02	0.05	0.000	0.00079	0.002
Thickness of terminal leads, including lead finish	A3	--	0.20 REF	--	--	0.0079 REF	--
Width of terminal leads	b	0.18	0.25	0.30	0.0071	0.0098	0.012
Package length / width	D / E	--	4.00 BSC	--	--	0.157 BSC	--
Length / width of exposed pad	D2 / E2	2.50	2.65	2.80	0.098	0.104	0.110
Lead pitch	e	--	0.50 BSC	--	--	0.020 BSC	--
Length of terminal for soldering to substrate	L	0.35	0.40	0.45	0.014	0.016	0.018
Number of terminal positions	N		20			20	

Note: the mm values are valid, the inch values contains rounding errors

11.5 Package Outline TSSOP16

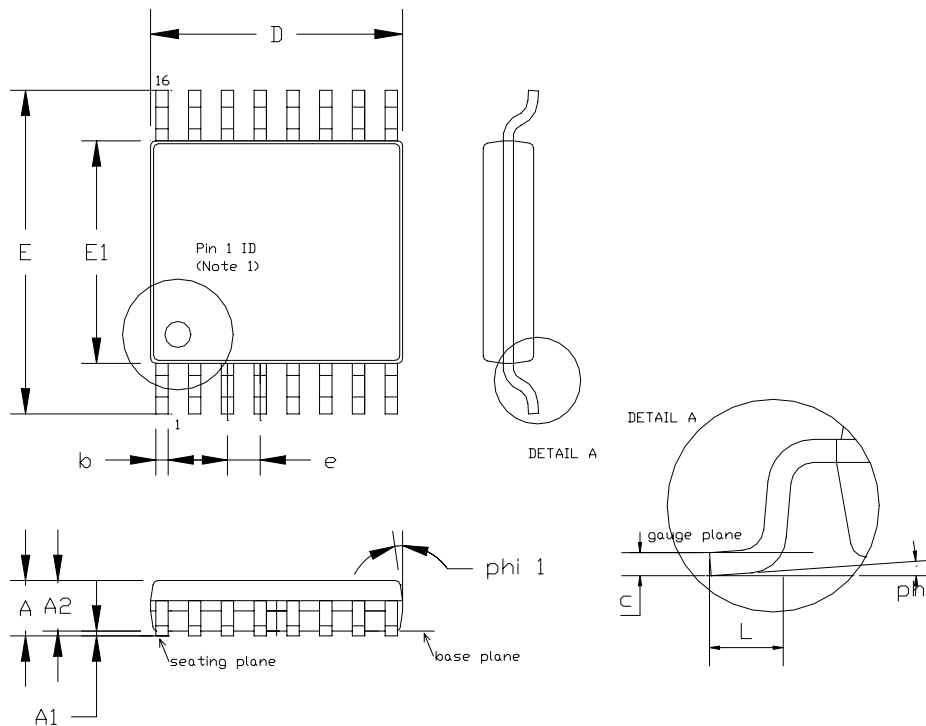

Description	Symbol	mm			inch		
		min	typ	max	min	typ	max
Package height	A	--	--	1.20	--	--	0.047
Stand off	A1	0.05	--	0.15	0.002	--	0.006
Package body thickness	A2	0.80	1.00	1.05	0.031	0.039	0.041
Width of terminal leads, inclusive lead finish	b	0.19	--	0.30	0.007	--	0.012
Thickness of terminal leads, inclusive lead finish	c	0.09	--	0.20	0.004	--	0.008
Package length	D	4.90	5.00	5.10	0.193	0.197	0.201
Package width	E	6.40 BSC			0.252 BSC		
Package body width	E1	4.30	4.40	4.50	0.169	0.173	0.177
Lead pitch	e	0.65 BSC			0.026 BSC		
Length of terminal for soldering to substrate	L	0.45	0.60	0.75	0.018	0.024	0.030
Angle of lead mounting area	phi [°]	0	--	8	0	--	8
mold release angle	phi1 [°]	12 REF			12 REF		
Number of terminal positions	N	16			16		

Note: the mm values are valid, the inch values contains rounding errors

12 Functional Safety

The development of this product is based on a process according to an ISO/TS16949 certified quality management system. Functional safety requirements according to ISO 26262 have not been submitted to Elmos and therefore have not been considered for the development of this product.

WARNING – Life Support Applications Policy

Elmos Semiconductor AG is continually working to improve the quality and reliability of its products. Nevertheless, semiconductor devices in general can malfunction or fail due to their inherent electrical sensitivity and vulnerability to physical stress. It is the responsibility of the buyer, when utilizing Elmos Semiconductor AG products, to observe standards of safety, and to avoid situations in which malfunction or failure of an Elmos Semiconductor AG Product could cause loss of human life, body injury or damage to property. In the development of your design, please ensure that Elmos Semiconductor AG products are used within specified operating ranges as set forth in the most recent product specifications.

General Disclaimer

Information furnished by Elmos Semiconductor AG is believed to be accurate and reliable. However, no responsibility is assumed by Elmos Semiconductor AG for its use, nor for any infringements of patents or other rights of third parties, which may result from its use. No license is granted by implication or otherwise under any patent or patent rights of Elmos Semiconductor AG. Elmos Semiconductor AG reserves the right to make changes to this document or the products contained therein without prior notice, to improve performance, reliability, or manufacturability.

Application Disclaimer

Circuit diagrams may contain components not manufactured by Elmos Semiconductor AG, which are included as means of illustrating typical applications. Consequently, complete information sufficient for construction purposes is not necessarily given. The information in the application examples has been carefully checked and is believed to be entirely reliable. However, no responsibility is assumed for inaccuracies. Furthermore, such information does not convey to the purchaser of the semiconductor devices described any license under the patent rights of Elmos Semiconductor AG or others.

Contact Information

Headquarters

Elmos Semiconductor AG
Heinrich-Hertz-Str. 1 • D-44227 Dortmund (Germany) ☎: +492317549100 ✉: sales-germany@elmos.com 🌐: www.elmos.com

Sales and Application Support Office North America

Elmos NA, Inc.
32255 Northwestern Highway • Suite 220 Farmington Hills
MI 48334 (USA) ☎: +12488653200 ✉: sales-usa@elmos.com

Sales and Application Support Office China

Elmos Semiconductor Technology (Shanghai) Co., Ltd.
Unit 16B, 16F Zhao Feng World Trade Building,
No. 369 Jiang Su Road, Chang Ning District,
Shanghai, PR China, 200050 ☎: +86216210 0908 ✉: sales-china@elmos.com

Sales and Application Support Office Korea

Elmos Korea
B-1007, U-Space 2, #670 Daewangpangyo-ro,
Sampyoung-dong, Bunddang-gu, Sungnam-si
Kyounggi-do 463-400 Korea ☎: +82317141131 ✉: sales-korea@elmos.com

Sales and Application Support Office Japan

Elmos Japan K.K.
BR Shibaura N Bldg. 7F
3-20-9 Shibaura, Minato-ku,
Tokyo 108-0023 Japan ☎: +81334517101 ✉: sales-japan@elmos.com

Sales and Application Support Office Singapore

Elmos Semiconductor Singapore Pte Ltd.
3A International Business Park
#09-13 ICON@IBP • 609935 Singapore ☎: +65 6908 1261 ✉: sales-singapore@elmos.com

© Elmos Semiconductor AG, 2015. Reproduction, in part or whole, without the prior written consent of Elmos Semiconductor AG, is prohibited.

Elmos Semiconductor AG reserves the right to change the detail specifications as may be required to permit improvements in the design of its products.