

REAL TIME CLOCK MODULE (SPI-Bus)

Built-in SRAM

RX-4581 NB

- Built in frequency adjusted 32.768 kHz crystal unit.
- Interface Type : 4-wire serial interface
- Operating voltage range : 1.6 V to 5.5 V
- Wide Timekeeper voltage range : 1.6 V to 5.5 V
- Low backup current : 0.4 μ A / 3 V (Typ.)
- Built-in SRAM : Built-in 128 bit (8 bit \times 16) RAM.
- 32.768 kHz frequency output function : C-MOS output With Control Pin
- The various functions include full calendar, alarm, timer.



Product Number (Please contact us)
RX-4581NB : Q41458192000200



Actual size



Block diagram

Overview

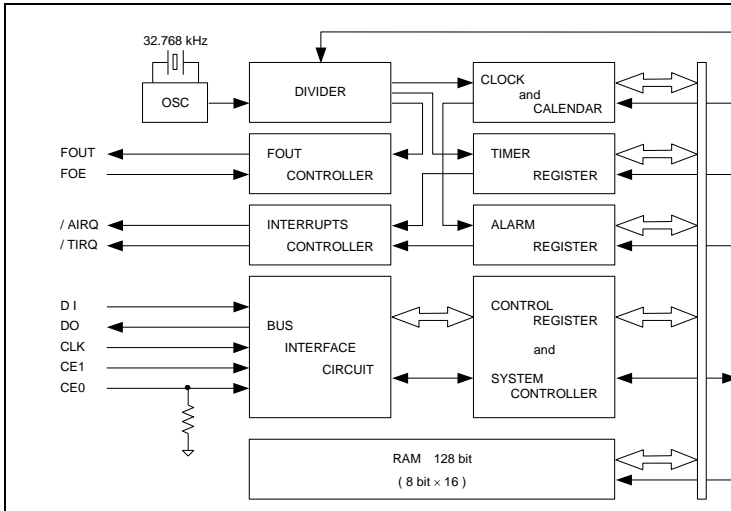

- **Built-in SRAM**
 - Include 128 bit (8 bit \times 16) RAM.
- **Interface Type**
 - Serial interface in 4 lines form.
 - It is possible to make it to 3 lines by wired-OR connecting DI and DO pins.
- **32.768 kHz frequency output function**
 - FOUT pin output (C-MOS output), CL=30 pF
 - FOE pin enables output on/off control.
- **Timer function**
 - Timer function can be set up between 1/4096 second and 4095 minutes.
 - It is recorded automatic to TF-bit at the time of event occurrence, and possible to output with /TIRQ pin output (open-drain output).
- **Interrupt function**
 - Alarm interrupt function, and timer interrupt function.

Pin Function

Terminal connection / External dimensions

(Unit:mm)

Signal Name	Input/Output	Function
CE0	Input	The chip enabled input pin 0. (It has a built -in pull-down resistance)
CE1	Input	The chip enabled input pin 1. (It does not have a built -in pull-down resistance)
CLK	Input	The shift clock input pin for serial data transfer.
DI	Input	The data input pin for serial data transfer.
DO	Output	The data output pin for serial data transfer.
FOUT	Output	This pin outputs the reference clock signal at 32.768 kHz (CMOS output). High impedance at the time of output off.
FOE	Input	The input pin for the FOUT output control.
/ AIRQ	Output	The open drain output pin for alarm and time update interrupts.
/ TIRQ	Output	The open drain output pin for timer interrupt.
VDD	—	Connected to a positive power supply.
GND	—	Connected to a ground.

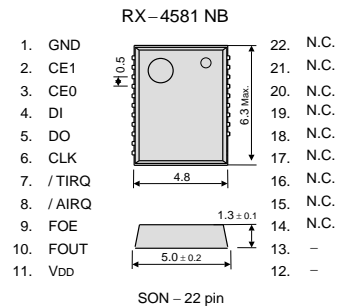

The metal case inside of the molding compound may be exposed on the top or bottom of this product. This purely cosmetic and does not have any effect on quality, reliability or electrical specs.

Specifications (characteristics)

* Refer to application manual for details.

Recommended Operating Conditions

Item	Symbol	Conditions	Min.	Typ.	Max.	Unit
Power voltage	VDD	—	1.6	3.0	5.5	V
Clock voltage	VCLK	—	1.6	3.0	5.5	V
Operating temperature	TOPR	—	-40	+25	+85	°C

Frequency characteristics

Item	Symbol	Conditions	Rating	Unit
Frequency tolerance	$\Delta f / f$	Ta = +25 °C VDD = 3.0 V	B: 5 \pm 23 *	$\times 10^{-6}$
Oscillation start-up time	tSTA	Ta = +25 °C VDD = 3.0 V	3 Max.	s

* Please ask for tighter tolerance. (Equivalent to 1 minute of monthly deviation)

Current consumption characteristics

Ta = -40 °C to +85 °C

Item	Symbol	Conditions	Min.	Typ.	Max.	Unit	
Current Consumption	IBK	CE0, CE1 = GND FOE = GND	VDD = 5 V	-	0.6	1.2	μ A
		FOUT ; output OFF (Hi - z)	VDD = 3 V	-	0.4	0.8	
	I32k	CE0, CE1 = GND FOE = VDD	VDD = 5 V	-	8.0	20.0	μ A
		FOUT ; 32.768 kHz output ON CL = 30 pF	VDD = 3 V	-	5.0	12.0	