

REAL TIME CLOCK MODULE (I²C-Bus)

RX-8581 SA/ JE/ NB

- Built-in frequency adjusted 32.768 kHz crystal unit.
- Interface Type : I²C-Bus Interface (400 kHz)
- Operating voltage range : 1.8 V to 5.5 V
- Wide Timekeeper voltage range : 1.6 V to 5.5 V
- Low backup current : 0.45 μA / 3 V (Typ.)
- 32.768 kHz frequency output function : C-MOS output With Control Pin
- The various functions include full calendar, alarm, timer.

* The I²C-Bus is a trademark of NXP Semiconductors



Product Number (Please contact us)
 RX-8581SA : Q41858152xxxx00
 RX-8581JE : Q41858171xxxx00
 RX-8581NB : Q41858192000200



Actual size



Block diagram

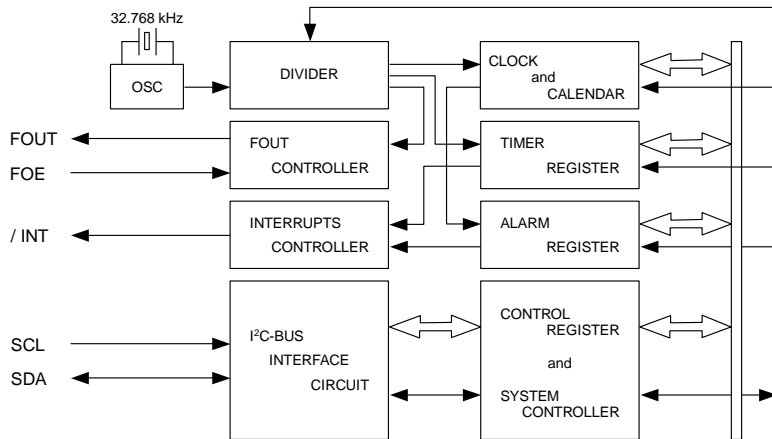

Overview

- **Interface Type**
 - I²C-Bus interface. (Hi-speed bus specifications 400 kHz)
 - * I²C-Bus slave address : read A3h and write A2h
- **32.768 kHz frequency output function**
 - FOUT pin output (C-MOS output), CL=30 pF
 - 32.768 kHz clock frequency output. (Duty 50 ±5 %)
- **Timer function**
 - Timer interrupt function can be set up between 1/4096 second and 4095 minutes.
 - It is recorded automatic to TF-bit at the time of event occurrence, and possible to output with /TIRQ pin output (N-ch open-drain output).
- **Interrupt function**
 - Alarm interrupt function, Time update interrupt function.

Terminal connection / External dimensions

(Unit:mm)

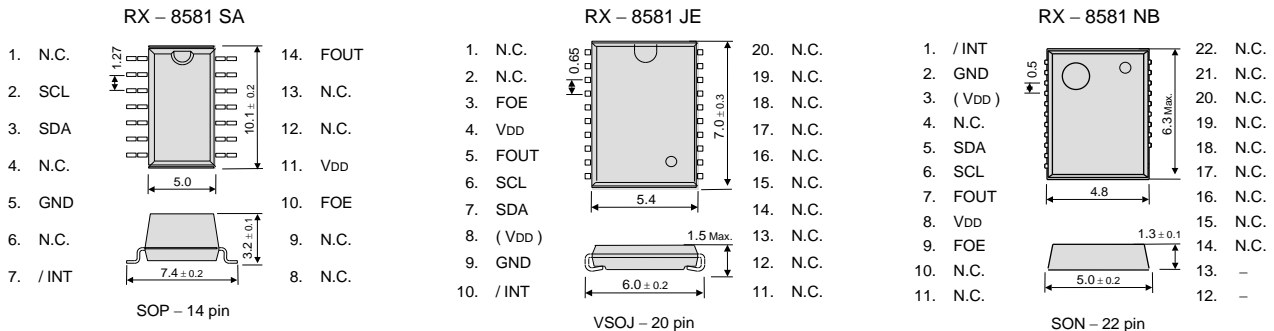

The metal case inside of the molding compound may be exposed on the top or bottom of this product. This purely cosmetic and does not have any effect on quality, reliability or electrical specs.

Specifications (characteristics)

* Refer to application manual for details.

Recommended Operating Conditions

Item	Symbol	Conditions	Min.	Typ.	Max.	Unit
Power voltage	V _{DD}	—	1.8	3.0	5.5	V
Clock voltage	V _{CLK}	—	1.6	3.0	5.5	V
Operating temperature	T _{OPR}	—	-40	+25	+85	°C

Frequency characteristics

Item	Symbol	Conditions	Rating	Unit
Frequency tolerance	Δ f / f	T _a = +25 °C V _{DD} = 3.0 V	B: 5 ± 23 *	× 10 ⁻⁶
FOUT output Duty	tw / t	T _a = -40 °C to +85 °C V _{DD} = 2.4 V to 5.5 V	50 ± 5	%

* Please ask for tighter tolerance. (Equivalent to 1 minute of monthly deviation)

Current consumption characteristics

T_a = -40 °C to +85 °C

Item	Symbol	Conditions	Min.	Typ.	Max.	Unit	
Current Consumption	I _{BK}	f _{SCL} = 0 Hz FOE = GND	V _{DD} = 5 V	-	0.65	1.2	μA
		FOUT ; output OFF (LOW)	V _{DD} = 3 V	-	0.45	0.8	
	I _{32k}	f _{SCL} = 0 Hz FOE = V _{DD}	V _{DD} = 5 V	-	8.0	20.0	μA
		FOUT ; 32.768 kHz output ON CL = 30 pF	V _{DD} = 3 V	-	5.0	12.0	