

Infrared Remote Control Receiver Module IRM-2638T

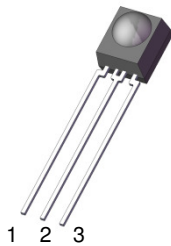

Pin Configuration

1. OUT
2. GND
3. V_{CC}

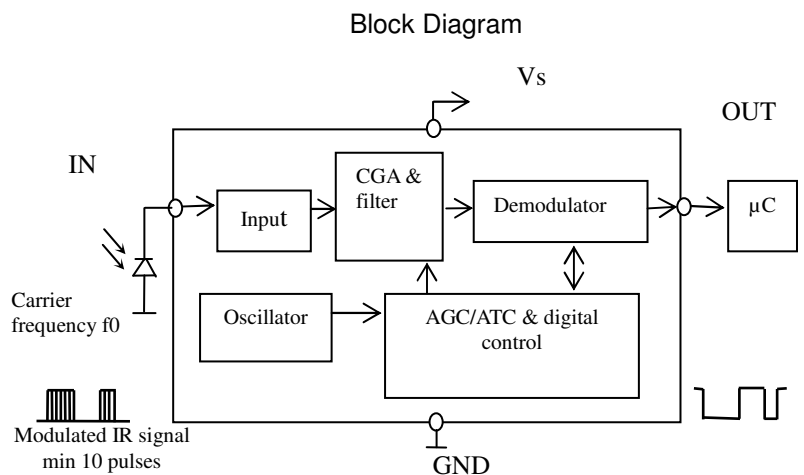

Features

- High protection ability against EMI
- Circular lens for improved reception characteristics
- Line-up for various center carrier frequencies.
- Low voltage and low power consumption.
- High immunity against ambient light.
- Photodiode with integrated circuit.
- TTL and CMOS compatibility.
- Long reception distance.
- High sensitivity.
- Pb free and RoHS compliant.

Description

The IRM-2638T device is miniature type infrared remote control system receiver which has been developed and designed by utilizing the most updated IC technology.

The PIN diode and preamplifier are assembled onto a lead frame and molded into a black epoxy package which operates as an IR filter. The demodulated output signal can directly be decoded by a microprocessor..

Applications

- Light detecting portion of remote control
- AV instruments such as Audio, TV, VCR, CD, MD, etc.
- Home appliances such as Air-conditioner, Fan, etc.
- The other equipments with wireless remote control.
- CATV set top boxes
- Multi-media Equipment

Application Circuit

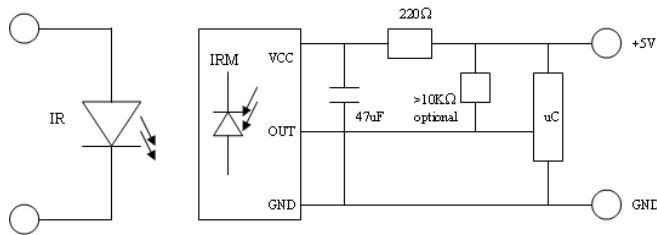

RC Filter should be connected closely between Vcc pin and GND pin.

Absolute Maximum Ratings (Ta=25°C)

Parameter	Symbol	Rating	Unit
Supply Voltage	Vcc	6	V
Operating Temperature	Topr	-25 ~ +85	°C
Storage Temperature	Tstg	-40 ~ +85	°C
Soldering Temperature ^{*1}	Tsol	260	°C

^{*1} 4mm from mold body for less than 10 seconds

Electro-Optical Characteristics (Ta=25°C, Vcc=5.0V)

Parameter	Symbol	Min.	Typ.	Max.	Unit	Condition
Current consumption	I _{CC}	---	1.0	1.2	mA	No input signal
B.P.F Center Frequency	F ₀	---	38	---	KHz	
Supply voltage	V _{CC}	4.5	-	5.5	V	
Peak wavelength	λ _p	---	940	---	nm	
Reception range	L ₀	14	---	---	m	At the ray axis *2
	L ₄₅	6	---	---		
	φ _h	---	45	---		
Half angle(horizontal)	φ _h	---	45	---	deg	
Half angle(vertical)	φ _v	---	45	---	deg	
High level pulse width	T _H	400	---	800	μs	At the ray axis *3
Low level pulse width	T _L	400	---	800	μs	
High level output voltage	V _H	4.5	---	---	V	
Low level output voltage	V _L	---	0.2	0.5	V	

2. The ray receiving surface at a vertex and relation to the ray axis in the range of θ=0° and θ=45°.
3. A range from 30cm to the arrival distance. Average value of 50 pulses.

Test method

The specified electro-optical characteristics is satisfied under the following Conditions at the controllable distance.

1. Measurement place

A place that is nothing of extreme light reflected in the room.

2. External light

Project the light of ordinary white fluorescent lamps which are not high Frequency lamps and must be less then 10 Lux at the module surface.
($E_e \leq 10 \text{Lux}$)

3. Standard transmitter

A transmitter whose output is so adjusted as to $V_o=400\text{mVp-p}$ and the output Wave form shown in Fig.-1. According to the measurement method shown in Fig.-2 the standard transmitter is specified. However, the infrared photodiode to be used for the transmitter should be $\lambda_p=940\text{nm}, \Delta\lambda=50\text{nm}$. Also, photodiode is used of PD438B ($V_r=5\text{V}$). (Standard light / Light source temperature 2856 °K).

4. Measuring system According to the measuring system shown in Fig.-3

Fig.-1 Transmitter Wave Form

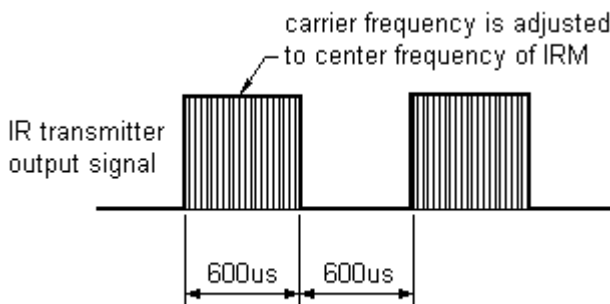

D.U.T output Pulse

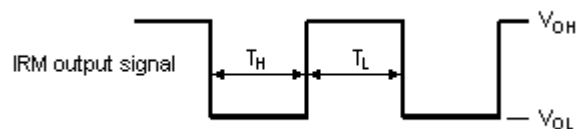

Fig.-2 standard transmitter calibration

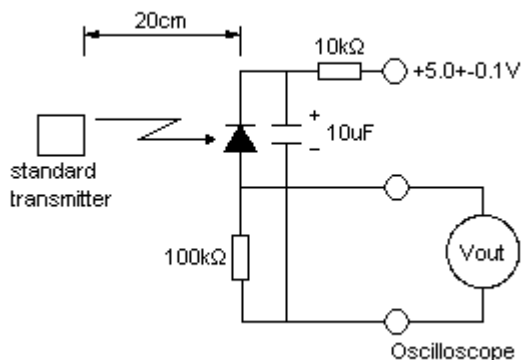
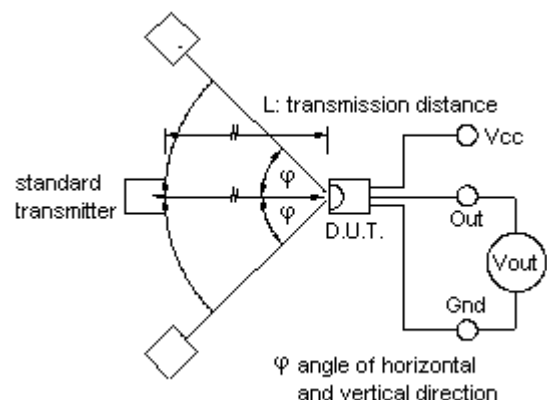

Fig.-3 Measuring System



Typical Electro-Optical Characteristics Curves

Fig.-4 Relative Spectral Sensitivity vs. Wavelength

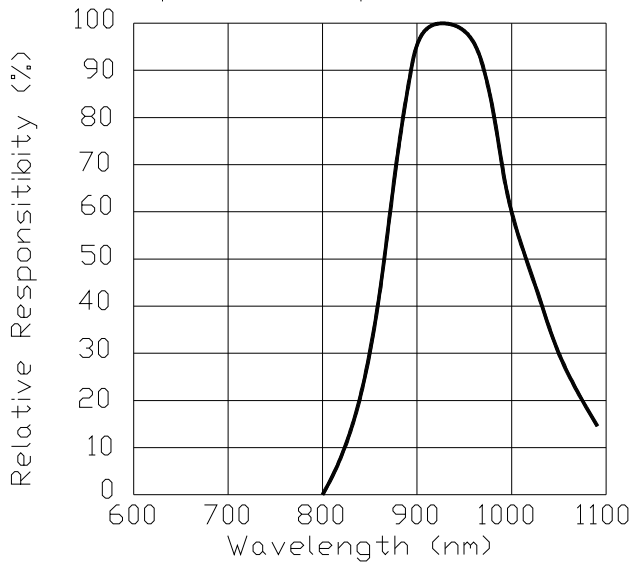

Fig.-5 Relative Transmission Distance vs. Direction

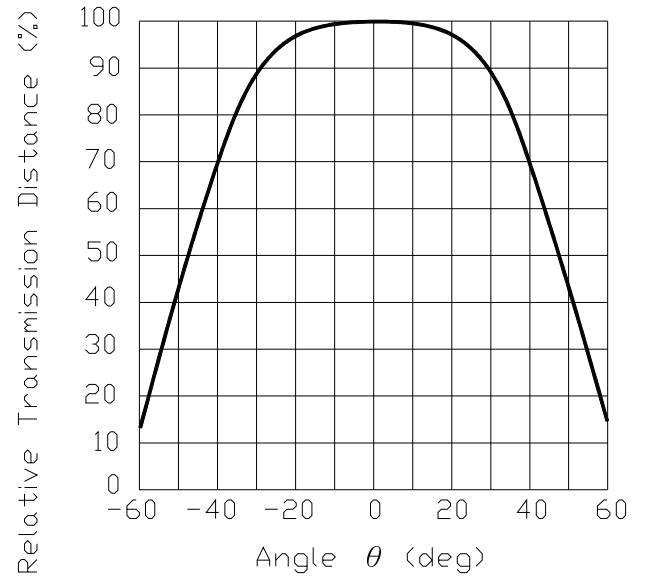

Fig.-6 Output Pulse Length vs. Arrival Distance

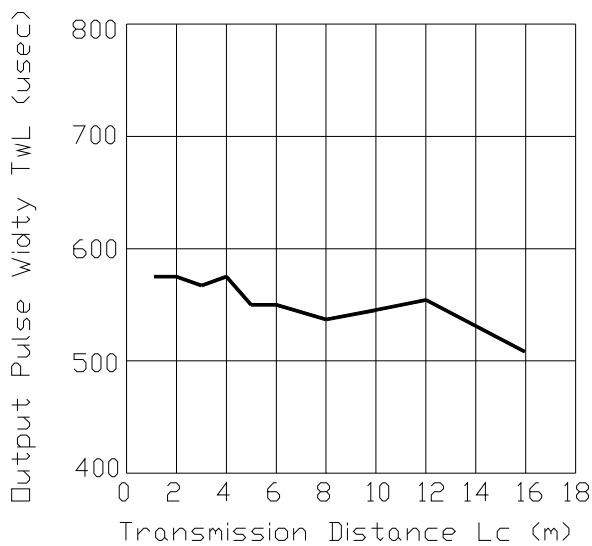

Fig.-7 Arrival Distance vs. Supply Voltage

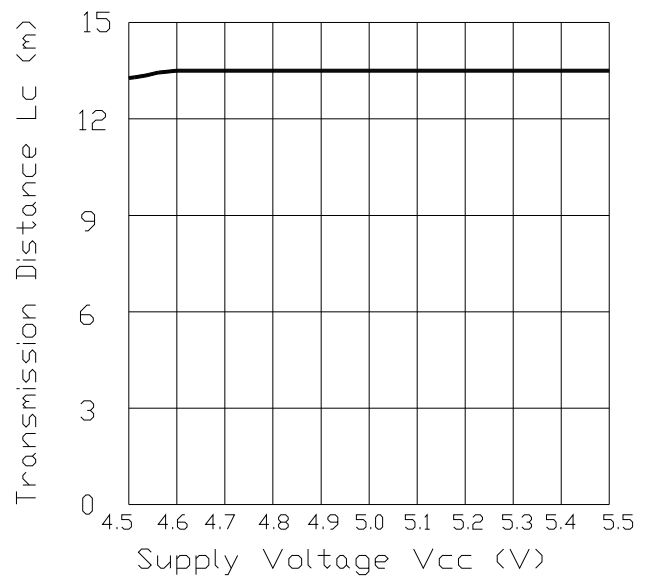

Fig.-8 Relative Transmission Distance vs
Center Carrier Frequency

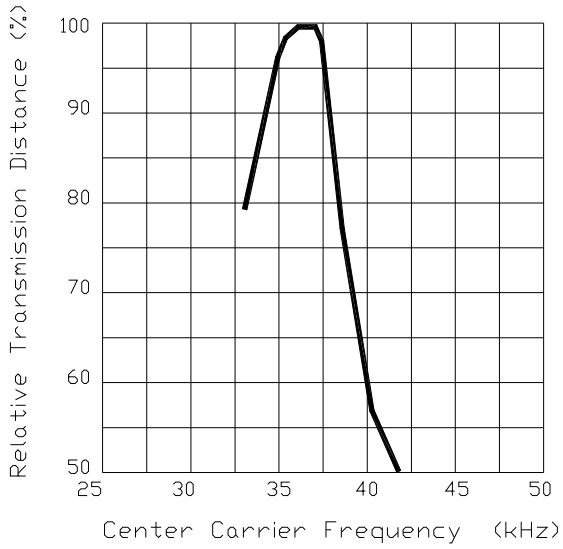
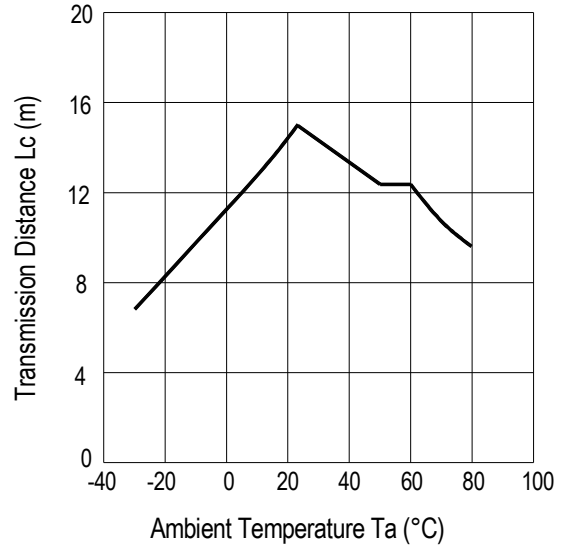

Fig.-9 Arrival Distance vs. Ambient Temperature



The Notice of Application:

Transmission of remote control signal consist of four parts: Encode Part, IR Transmitter Source, IRM device, Decode Part

1. When IRM-2638T code select frequency, it need to well understand the center system of encode part.
2. Strong or weak light of IR Transmitter can affect distance of transmission.
3. When using IRM-2638T device, it requires the composition of code pattern to reach the demand as follows:

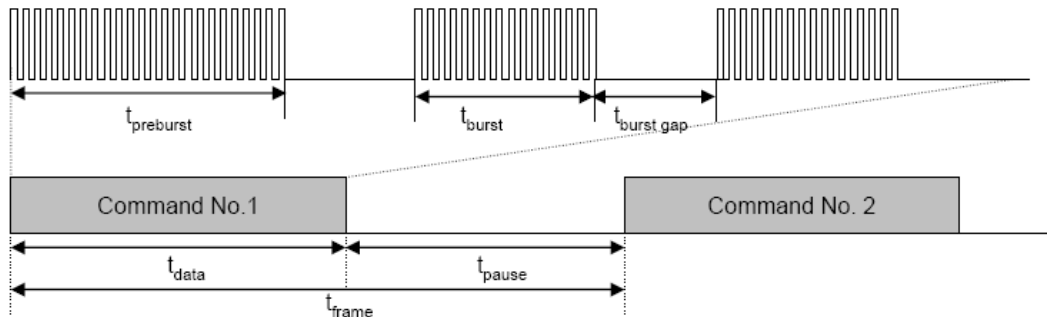

Minimum t_{burst} (number of pulses per burst)	Minimum t_{burst_gap} (number of pulses between two burst)	Minimum t_{pause}
10 pulses	14 pulses	25 msec

4. It needs to ensure the translation range of decode part if it is applied to the pulse-width range.

If the above items hardly assure of its application, it'll cause NG(no good) message from the edge of signal.

Package Dimension
(Dimensions in mm)

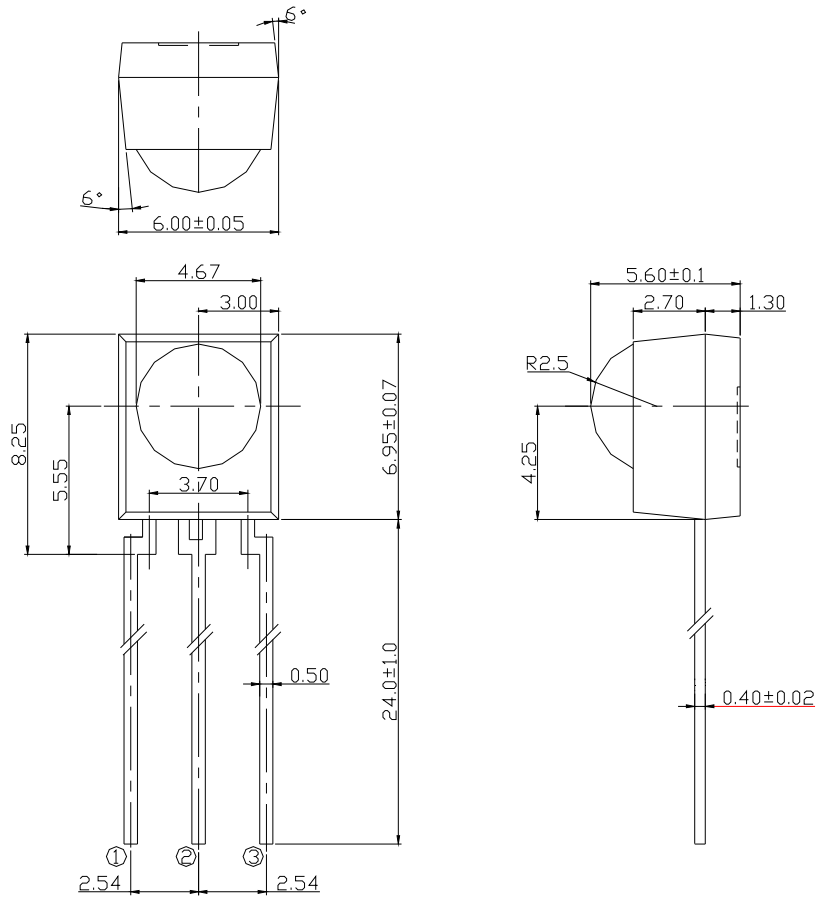

Notes:
Tolerances unless dimensions ± 0.3 mm.

Tapping size

Description	Symbol	Dimension	Tolerance
Component Body Height	A	6.95	±0.3
Component Body Width	B	6	±0.3
Component Body Thickness	C	5.60	±0.3
Component Lead Width	d	0.5	±0.05
Tape Feeding Hole Diameter	D	4.0	±0.2
Lead Pitch	F1 / F2	2.54	±0.2
Feed Hole To Button Of Component	H	22	±0.5
Length From Seating plane	H1	20.7	±0.5
Lead Clinch Height	H2	26.25	±0.5
Body Inclination	$\Delta h / \Delta P$	3 deg	±2.0
Feeding Hold Pitch	P1	12.7	±0.2
Feeding Hold Alignment	P2	6.35	±1.0
Tape Width	W1	18.0	±0.5
Feeding Hold Alignment	W2	9.0	±0.5
Adhesive Tape Width	W3	13.1	±0.5
Adhesive Tape Margin	W4	0.5	Min.0
Total Tape Thickness	t	0.65	±0.2

Packing Quantity

2000 pcs / Box
10 Boxes / Carton

Application Restrictions

1. Above specification may be changed without notice. EVERLIGHT will reserve authority on material change for above specification.
2. When using this product, please observe the absolute maximum ratings and the instructions for use outlined in these specification sheets. EVERLIGHT assumes no responsibility for any damage resulting from use of the product which does not comply with the absolute maximum ratings and the instructions included in these specification sheets.
3. These specification sheets include materials protected under copyright of EVERLIGHT. Reproduction in any form is prohibited without the specific consent of EVERLIGHT.