

Tous droits strictement reserves. Reproduction ou communication a des tiers interdite sous quelque forme que ce soit sans autorisation ecrite du proprietaire. Propriete de c FCI. Droits de reproduction FCI.

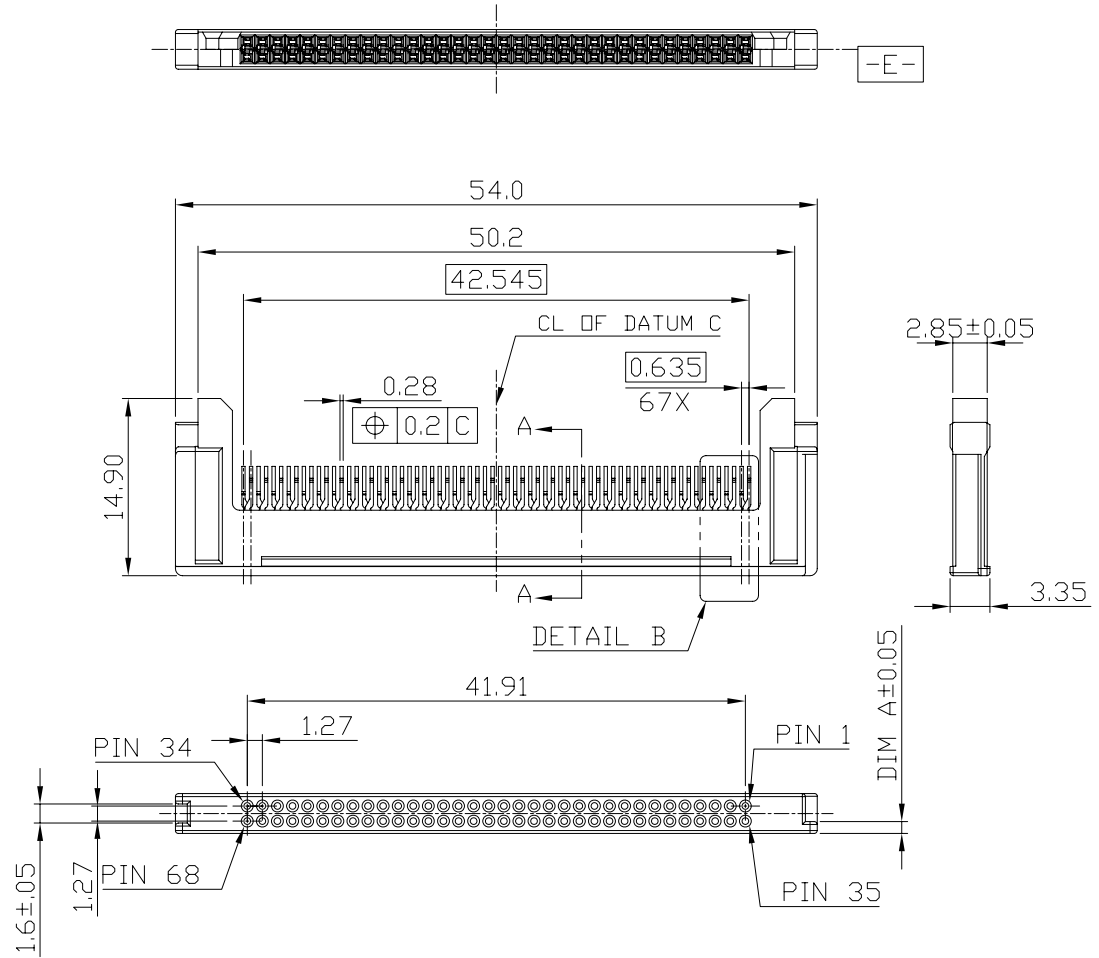

All rights strictly reserved. Reproduction or issue to third parties in any form whatever is not permitted without written authority from the proprietor. Property of FCI. Copyright FCI.

PRODUCT NO.	DIM A	VOLTAGE KEY	BOARD OFFSET DIM C	PACKING
10014744				
-002 (-N02)	1.0	5.0V	0.3	SEE NOTE 5 FOR DETAIL DESCRIPTION
-003 (-N03)	1.0	5.0V	0	
-004 (-N04)	1.0	5.0V	-0.3	
-006 (-N06)	2.1	3.3V	0.3	
-007 (-N07)	2.1	3.3V	0	
-008 (-N08)	2.1	3.3V	-0.3	
-011 (N11)	1.0	5.0V	0.6	
-012 (-N12)	2.1	3.3V	0.6	
-013 (-N13)	1.0	5.0V	-0.6	
-014 (-N14)	2.1	3.3V	-0.6	
-015 (-N15)	1.0	5.0V	-0.8	
-021 (-N21)	1.0	5.0V	0	
SEE NOTE 6 FOR -NXX DETAIL				
SEE NOTE 7 FOR LEAD FREE DETAIL				
(NOTE: -021 & -N21 IS REVERSED TYPE)				



mat'l. code				tolerances unless otherwise specified				CUSTOMER COPY		FCI	
ltr	ecn no	dr	date							www.fciconnect.com	
H	0G08-0116	NZ	05/27/08	linear	.X ±.3			projection		title	
					.XX ±.13					68PIN PCMCIA RECEPTACLE ASS'Y	
					.XXX ±.050					product family	PCMCIA
C	T03-0099	TAI	03/21/03	angles	0° ±2'					size	dwg no
D	T03-0186	TAI	05/21/03	dr		KENNY TAI	12/17/02	← MM →			code
E	T03-0332	TAI	07/22/04	enrg		KENNY TAI	12/17/02				-
F	T03-0358	TAI	08/23/04	chr		KENNY TAI	12/17/02				sheet
G	0G06-0154	CS	04/06/06	appd		PAUL WANG	12/17/02	scale	1:1	A3	10014744
sheet index	revision sheet	H	H	H	H						1 of 4
		1	2	3	4						



cage code 22526

All rights strictly reserved. Reproduction or issue to third parties in any form whatever is not permitted without written authority from the proprietor. Property of FCI. Copyright FCI.

Tous droits strictement réservés. Reproduction ou communication à des tiers interdite sous quelque forme que ce soit sans autorisation écrite du propriétaire. Propriété de c FCI. Droits de reproduction FCI.

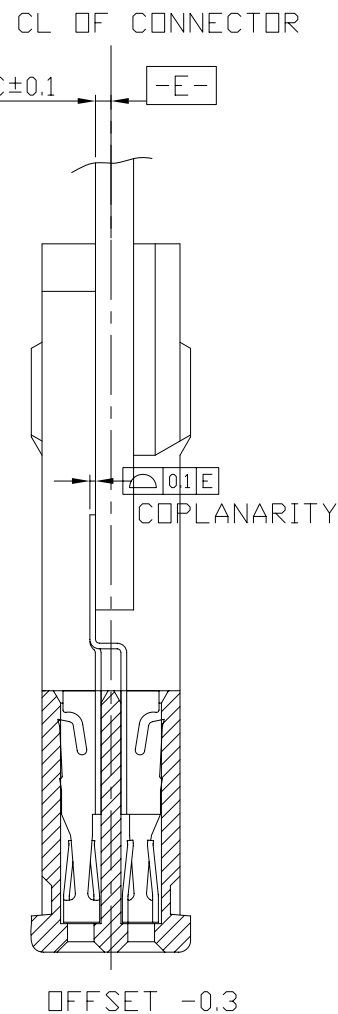
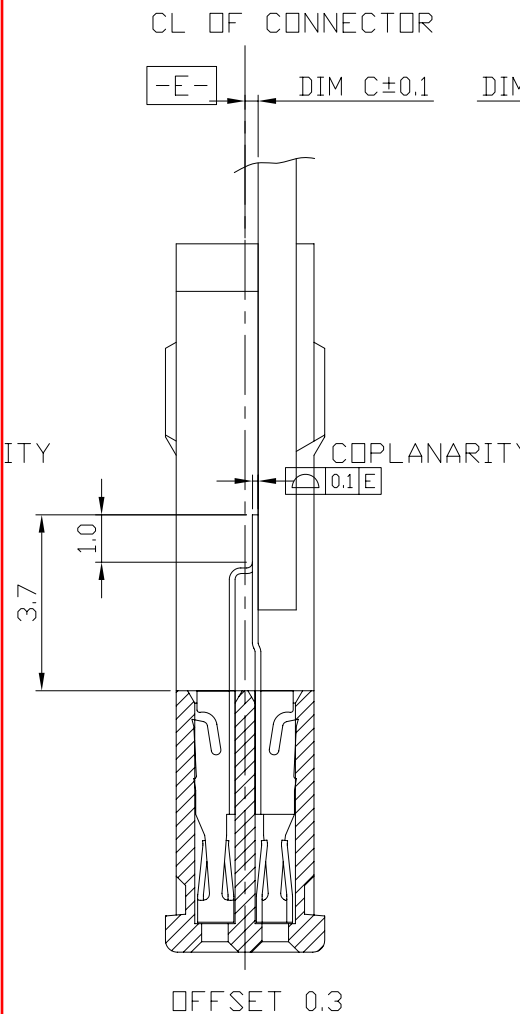
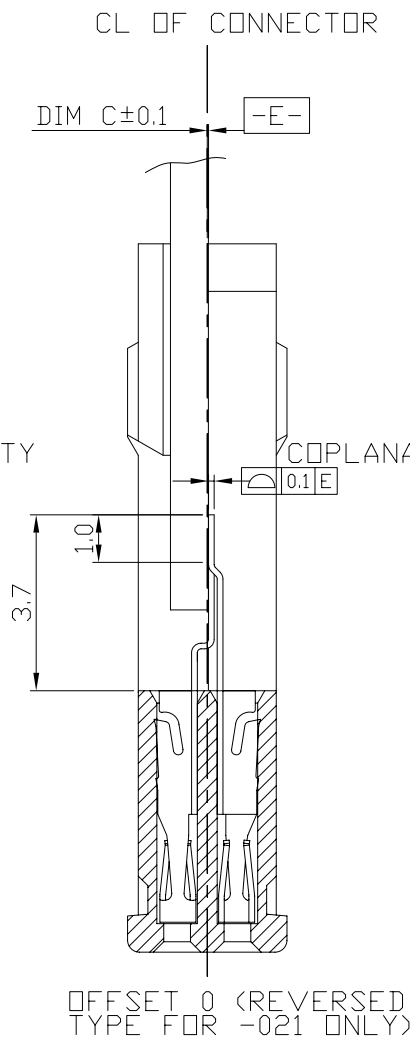
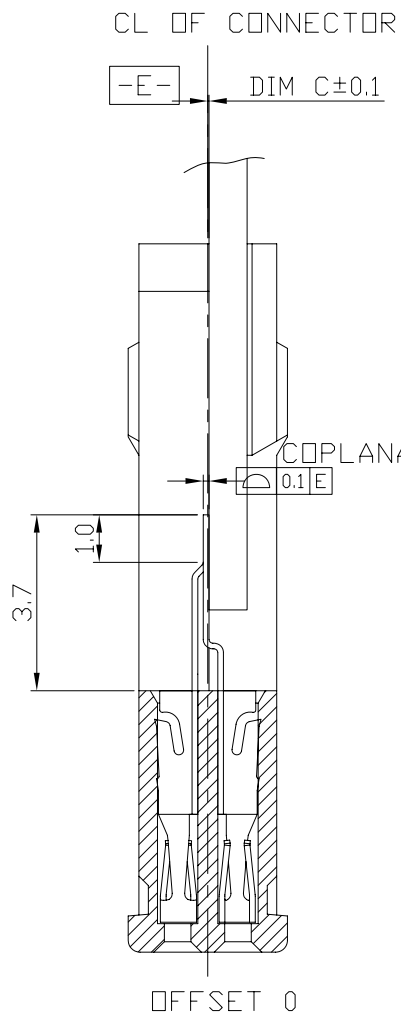
A
FCI



mat'l. code				tolerances unless otherwise specified			CUSTOMER COPY		 www.fciconnect.com	
ltr	ecn no	dr	date	linear	.X ±.3	projection	title			
H					.XX ±.13		68PIN PCMCIA RECEPTACLE ASS'Y			
				angles	.XXX ±.050		product family	PCMCIA	code	
				dr	0° ±2'	← MM →	size	dwg no	sheet	
				engr	KENNY TAI 12/17/02	scale	A3	10014744	2 of	
				chr	KENNY TAI 12/17/02	1:1				
				appd	PAUL WANG 12/17/02					
sheet index	revision sheet									

sheet index revision sheet

cage code 22526

All rights strictly reserved. Reproduction or issue to third parties in any form whatever is not permitted without written authority from the proprietor. Property of FCI. Copyright FCI.

Tous droits strictement réservés. Reproduction ou communication à des tiers interdite sous quelque forme que ce soit sans autorisation écrite du propriétaire. Propriété de c FCI. Droits de reproduction FCI.

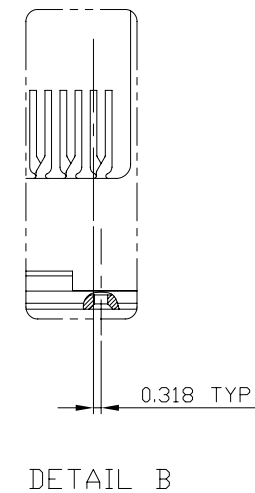
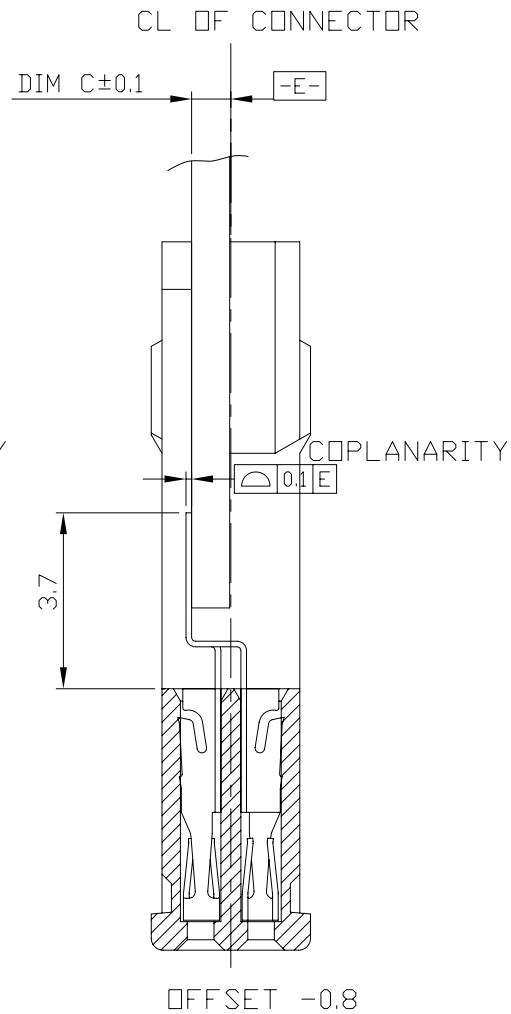
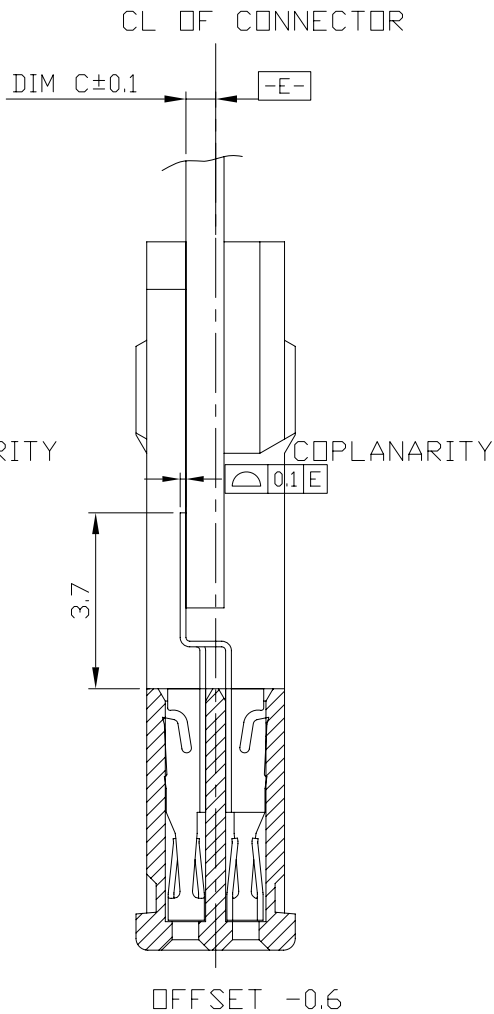
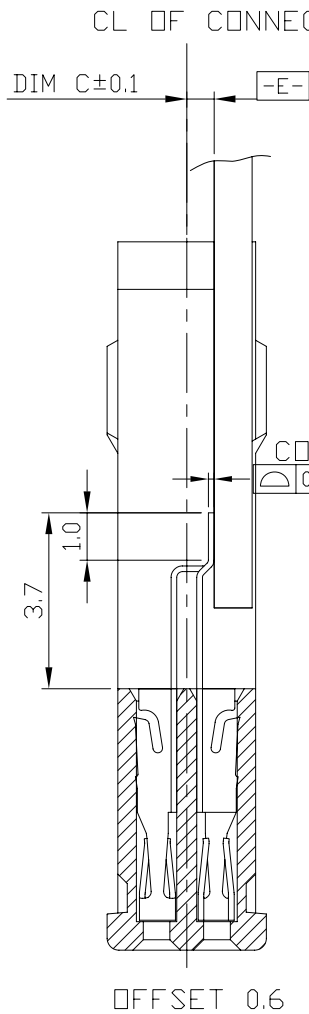

mat'l. code				tolerances unless otherwise specified			CUSTOMER COPY	 www.fciconnect.com	
ltr	ecn no	dr	date	linear	.X ±.3	projection			title
H					.XX ±.13			68PIN PCMCIA RECEPTACLE ASS'Y	
				angles	.XXX ±.050				product family PCMCIA code -
				dr	0° ±2'		MM	size	
				engr		scale			dwg no
				chr	KENNY TAI 12/17/02		1:1	A3	
				appd	PAUL WANG 12/17/02	10014744			
sheet index	revision sheet							code	
								22526	

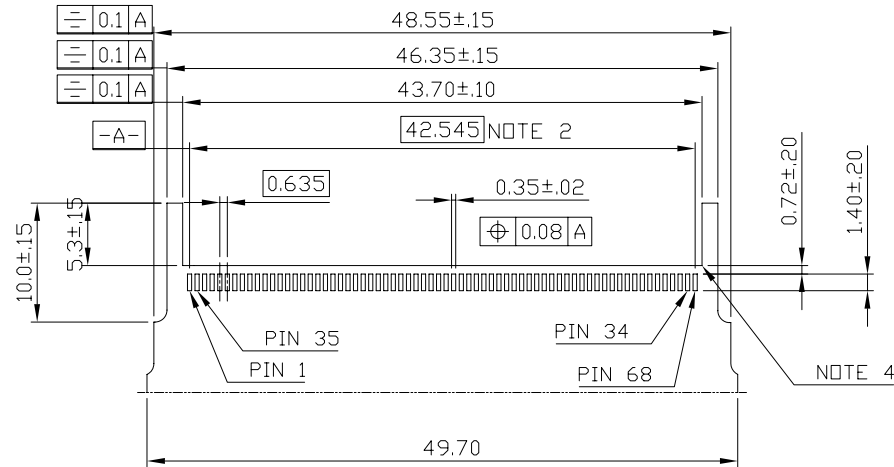

RECOMMENDED P.C.B. LAYOUT

NOTE:

- MATERIAL:
CONTACT: PHBR 0.12t
HOUSING: LCP UL94V-0 (BLACK COLOR: -XXX; NATURAL COLOR: -NXX)
- FINISH:
CONTACT: ALL OVER--- Ni UNDER 0.5 MICRON THK.
CONTACT AREA--- Au or GXT 0.38 MICRON THK.
- SOLDER TAIL---TIN LEAD 2.5 MICRON THK.
- MAXIMUM PCB BOW ON THIS DIMENSION IS 0.1mm.
- PACKING SPEC. REFER TO GS-14-723.
- ELIMINATE THE CORNER TO PREVENT INTERFERENCE WITH SOLDER TAIL.
- XXX (-NXX) USE STD. PACKAGE, 1872 PCS / CARTON;
-XXXT (-NXXT) USE TAPE AND REEL, 750 PCS / REEL;
-XXXX (-NXXX) USE STD. PACKAGE, 200 PCS / CARTON;
-XXXXA (-NXXXA) USE TAPE AND REEL, 600 PCS / REEL.
- NXX USE NATURAL COLOR HOUSING. EX. -N02 IS THE SAME WITH -002 EXCEPT NATURAL COLOR.
- XXXXLF IS LEAD FREE PLATING. SOLDER TAIL IS PLATED TIN 2.5 MICRON.
- PRODUCT SPEC. REFER TO GS-12-228.

mat'l. code				tolerances unless otherwise specified				CUSTOMER COPY		FCI www.fciconnect.com	
ltr	ecn no	dr	date	linear	.X ±.3			projection	title		
H					.XX ±.13				68PIN PCMCIA RECEPTACLE ASS'Y		
				angles	.XXX ±.050				product family PCMCIA		
					0° ±2'				code -		
				dr	KENNY TAI	12/17/02	MM	size		sheet	
				engr	KENNY TAI	12/17/02		10014744		4 of	
				chr	KENNY TAI	12/17/02	scale	A3			
				appd	PAUL WANG	12/17/02		1:1			
sheet index	revision sheet										

cage code 22526