	TYPE PRODUCT SPECIFICATION	NUMBER GS-12-292	
	TITLE ExpressCard Module Card Kit	PAGE 1 of 14	REVISION C
AUTHORIZED BY SH MIAO		DATE 2011-05-29	
CLASSIFICATION UNRESTRICTED			

1.0 **OBJECTIVE**

This product specification defines the performance, test, quality and reliability requirements of ExpressCard module card kit.

2.0 **SCOPE**

This product specification is applicable to provide information regarding product feature, material of ExpressCard module card kit, and all products shall meet ExpressCard Standard, PCMCIA/JEITA.

2.1 ABBREVIATIONS:

PCMCIA	Personal Computer Memory Card International Association
JEITA	Japan Electronics and Information Technology Industries Association
PCI	Peripheral Component Interface
PCI Express	A scalable full-simplex serial bus standard which operates at 2.5Gbps and offers both asynchronous and isochronous data transfers
USB	Universal Serial Bus

3.0 **GENERAL**

This document is composed of the following sections:

- 1.0 OBJECTIVE
- 2.0 SCOPE
 - 2.1 ABBREVIATIONS
- 3.0 GENERAL
- 4.0 APPLICABLE DOCUMENTS
 - 4.1 ExpressCard Standard
 - 4.2 PC Card Standard
 - 4.3 Other Standard and Specification
- 5.0 REQUIREMENTS
 - 5.1 General Description
 - 5.2 Material
 - 5.3 Cosmetic Requirements
 - 5.4 Dimensions
- 6.0 CARD KIT PERFORMANCE
 - 6.1 Environmental Performance

This document is the property of and embodies CONFIDENTIAL and PROPRIETARY information of FCI Electronics. No part of the information shown on this document may be used in any way without the written consent of FCI Electronics.

	TYPE PRODUCT SPECIFICATION	NUMBER GS-12-292	
	TITLE ExpressCard Module Card Kit	PAGE 2 of 14	REVISION C
AUTHORIZED BY SH MIAO		DATE 2011-05-29	
CLASSIFICATION UNRESTRICTED			

- 6.1.1 Operating Environment
- 6.1.2 Storage Environment
- 6.1.3 High Storage Temperature
- 6.1.4 Low Storage Temperature
- 6.1.5 High Operating Temperature
- 6.1.6 Low Operating Temperature
- 6.1.7 Thermal Shock
- 6.1.8 Moisture Resistance

6.2 Mechanical Performance

- 6.2.1 Test Sequence
- 6.2.2 Vibration and High Frequency
- 6.2.3 Shock
- 6.2.4 Bend Test
- 6.2.5 Torque Test
- 6.2.6 Drop Test

6.3 Electrical Performance

- 6.3.1 Contact Resistance between Module Card Kit and Ground
- 6.3.2 Life Cycle Testing in Office Environment
- 6.3.3 Electrostatic Discharge
- 6.3.4 Electromagnetic Field Interference
- 6.3.5 Insulator

7.0 REVISION HISTORY

4.0 APPLICABLE DOCUMENTS

- 4.1 ExpressCard Standard Release 1.0 of December 2003.
- 4.2 PC Card Standard: Volume 3 (Physical Specification) Release 8.0 of April 2001.
- 4.3 Other Standard and Specification:
 - 4.3.1 International Standard IEC 512, Electromechanical components for electronic equipment; basic testing procedures and measuring methods.
 - 4.3.2 EIA-364, Electrical connector/socket test procedures including environmental classifications.
 - 4.3.3 MIL-STD-202, Military Standard, test method for electronics and electrical component parts.

5.0 REQUIREMENTS

5.1 General Description:

There are two formats of the standard ExpressCard module card kit herein, the ExpressCard/34 module characterized by its 34mm width and the ExpressCard/54 module characterized by its 54mm width.

This document is the property of and embodies CONFIDENTIAL and PROPRIETARY information of FCI Electronics. No part of the information shown on this document may be used in any way without the written consent of FCI Electronics.

	TYPE PRODUCT SPECIFICATION	NUMBER GS-12-292	
TITLE ExpressCard Module Card Kit		PAGE 3 of 14	REVISION C
		AUTHORIZED BY SH MIAO	DATE 2011-05-29
		CLASSIFICATION UNRESTRICTED	

Each format consists of two stainless steel card shields, one (two) plastic end cap, and one 26 position SMT receptacle connector.

FCI manufactures the ExpressCard module card kit without PCB. For this reason, this FCI specification will only cover the specifications of the “empty” card kit, except for vibration, bend, torque and shock tests. It is, in this area, different from the ExpressCard Standard and PC Card Standard.

The electrical tests need a PCB, In that case only, a dummy one is to be added on which a 26 position SMT receptacle connector is soldered.

5.2 Material:

5.2.1 Receptacle Connector: Housing: High temperature thermoplastic, UL 94V-0 flame retardant.
Terminal: Copper Alloy, gold flash over contact area, lead-free soldering.

5.2.2 Metal Shield: SUS 304 Stainless Steel.

5.2.3 Plastic End Cap: ABS + PC, UL 94V-0 flame retardant.

5.3 Cosmetic Requirements:

The card shields must comply with the following cosmetic requirements:

- Surface finish: matte / dull (not brushed).
- The outside surfaces of the card shield must be free of scratches, dents, spots, finger prints, cleaning residue or other irregularities.

The outside surfaces of plastic end cap must be free of scratches, flash, mark, blemish, protrusion, weld-line, incomplete molding or other irregularities.

5.4 Dimensions:

The card kit dimensions must meet the requirements from the figures below, both for the ExpressCard/34 card kit and the ExpressCard/54 card kit.



TYPE
PRODUCT SPECIFICATION

NUMBER
GS-12-292

TITLE
ExpressCard Module Card Kit

PAGE
4 of 14

REVISION
C

AUTHORIZED BY
SH MIAO

DATE
2011-05-29

CLASSIFICATION
UNRESTRICTED

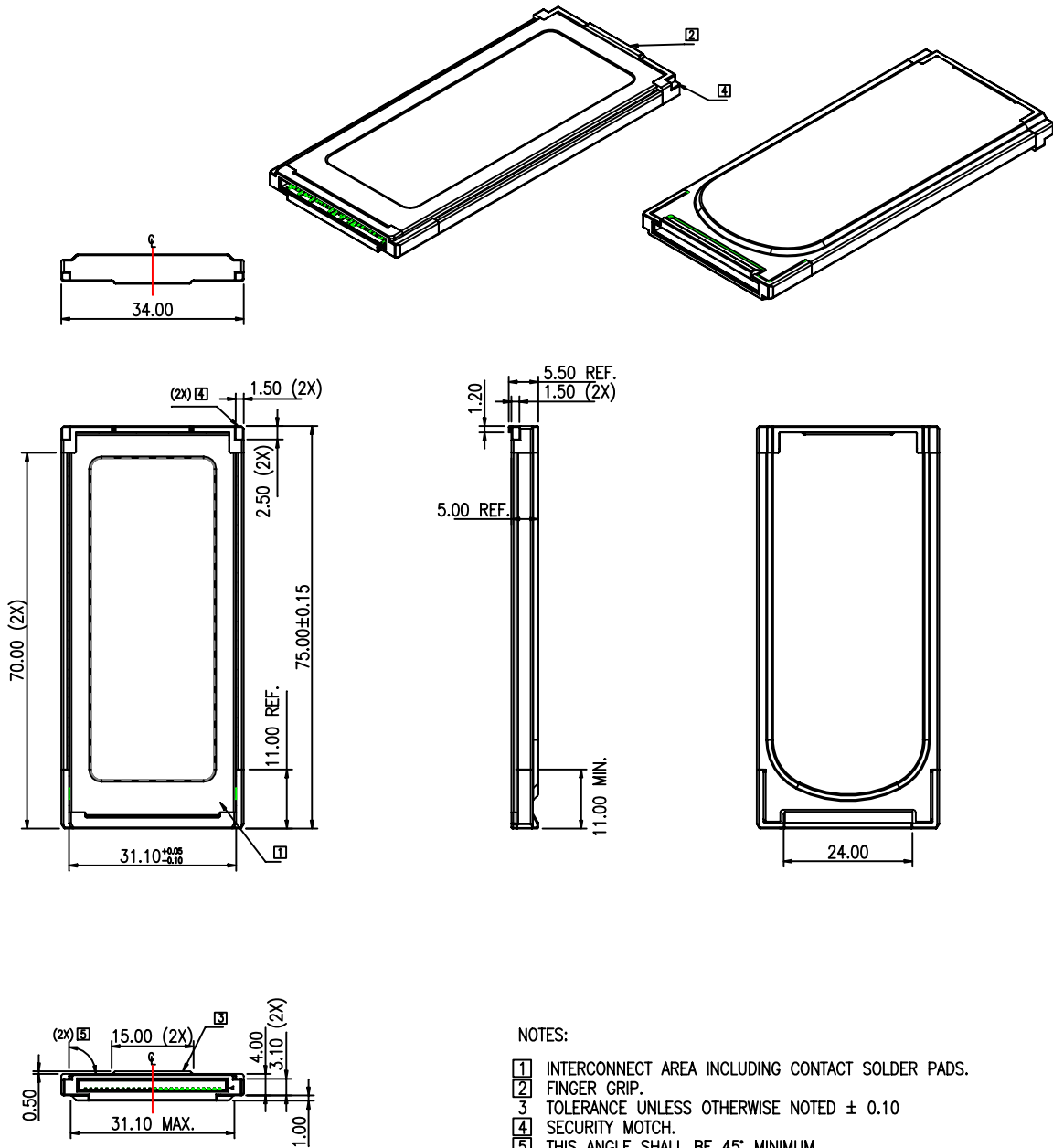

NOTES:

- 1 INTERCONNECT AREA INCLUDING CONTACT SOLDER PADS.
- 2 FINGER GRIP.
- 3 TOLERANCE UNLESS OTHERWISE NOTED ± 0.10
- 4 SECURITY MOTCH.
- 5 THIS ANGLE SHALL BE 45° MINIMUM.

This document is the property of and embodies CONFIDENTIAL and PROPRIETARY information of FCI Electronics. No part of the information shown on this document may be used in any way without the written consent of FCI Electronics.



TYPE
PRODUCT SPECIFICATION

NUMBER
GS-12-292

TITLE
ExpressCard Module Card Kit

PAGE
5 of 14

REVISION
C

AUTHORIZED BY
SH MIAO

DATE
2011-05-29

CLASSIFICATION
UNRESTRICTED

Figure: ExpressCard/34 Module Outline Dimensions

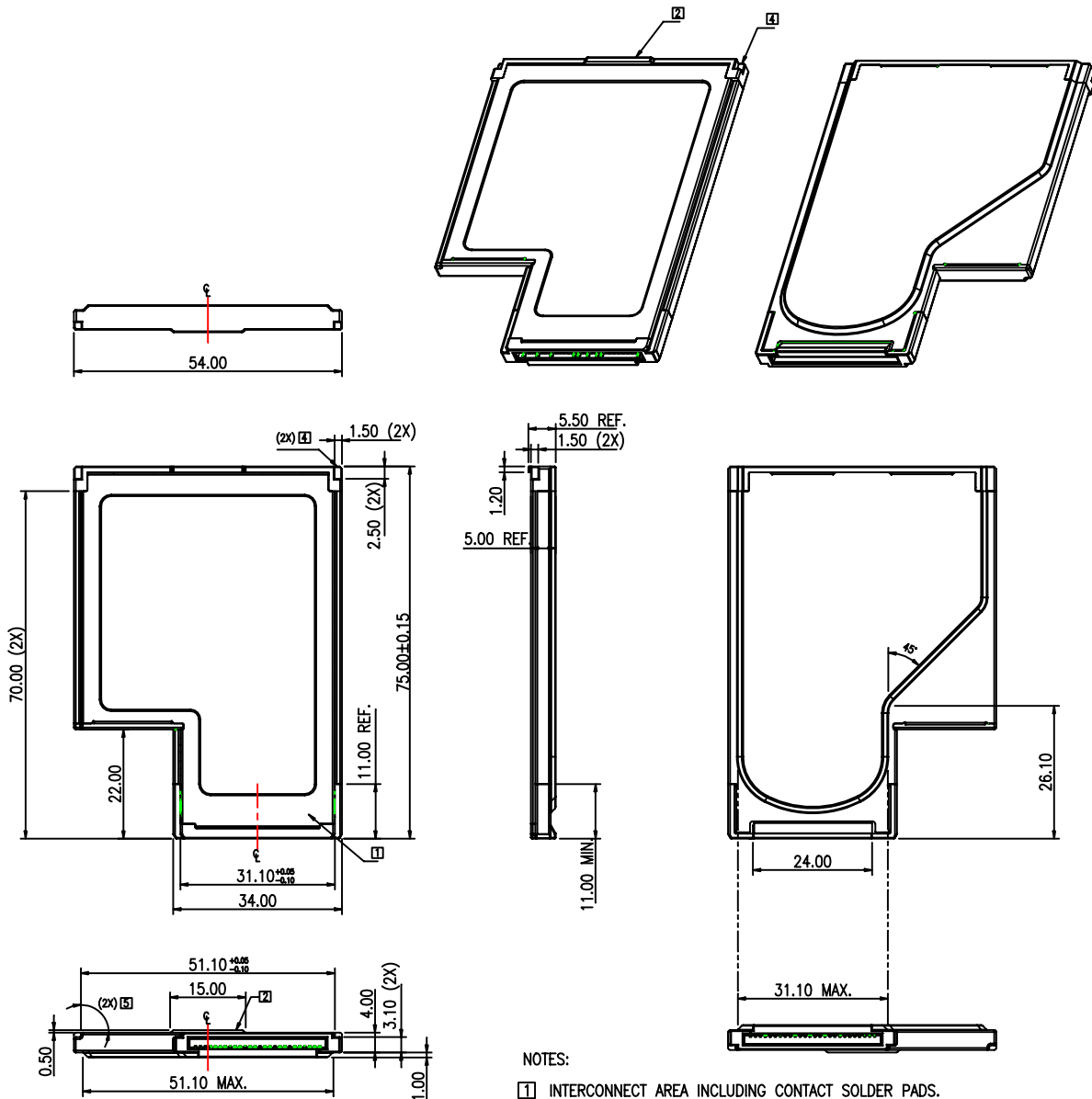

- NOTES:
- 1 INTERCONNECT AREA INCLUDING CONTACT SOLDER PADS.
 - 2 FINGER GRIP.
 - 3 TOLERANCE UNLESS OTHERWISE NOTED ± 0.10
 - 4 SECURITY MOTCH.
 - 5 THIS ANGLE SHALL BE 45° MINIMUM.

This document is the property of and embodies CONFIDENTIAL and PROPRIETARY information of FCI Electronics. No part of the information shown on this document may be used in any way without the written consent of FCI Electronics.

	TYPE PRODUCT SPECIFICATION	NUMBER GS-12-292	
	TITLE ExpressCard Module Card Kit	PAGE 6 of 14	REVISION C
AUTHORIZED BY SH MIAO		DATE 2011-05-29	
CLASSIFICATION UNRESTRICTED			

Figure: ExpressCard/54 Module Outline Dimensions

6.0 CARD KIT PERFORMANCE

The ExpressCard module card kit shall meet or exceed all reliability test requirements as described below.

Unless otherwise specified, all test and measurements shall be made according to the following standard conditions.

Temperature	15°C to 35°C
Air pressure	86 to 106 kPa
Relative humidity	25% to 85%

6.1 Environmental Performance:

The ExpressCard module card kit storage and operating environment are specified in this section.

6.1.1 Operating Environment

STANDARD
Operating Temperature: -40°C to +85°C
Relative humidity: 95% maximum (non-condensing)

6.1.2 Storage Environment

STANDARD
Storage Temperature: -20°C to +65°C
Relative humidity: 95% maximum (non-condensing)

6.1.3 High Storage Temperature

STANDARD	TESTING
Module to function as specified after test and all non-volatile memory to retain the data stored prior to test. The form and dimensions must conform to the physical use requirements of these specifications after testing. Scratches, color and other appearance items shall depend on the specifications of the manufacturer for each module and are not a basis for evaluation here.	Test Condition 65°C and 90-95% RH for 96 hours minimum, all voltage inputs = 0

	TYPE	PRODUCT SPECIFICATION		NUMBER	GS-12-292		
	TITLE			PAGE	7 of 14	REVISION	C
ExpressCard Module Card Kit			AUTHORIZED BY	SH MIAO		DATE	2011-05-29
			CLASSIFICATION			UNRESTRICTED	

6.1.4 Low Storage Temperature

STANDARD	TESTING
<p>Module to function as specified after test and all non-volatile memory to retain the data stored prior to test.</p> <p>The form and dimensions must conform to the physical use requirements of these specifications after testing.</p> <p>Scratches, color and other appearance items shall depend on the specifications of the manufacturer for each module and are not a basis for evaluation here.</p>	<p>Test Condition -20°C for 96 hours minimum, all voltage inputs = 0</p>

6.1.5 High Operating Temperature

STANDARD	TESTING
<p>Module to function as specified after test and all non-volatile memory to retain the data stored prior to test.</p> <p>The form and dimensions must conform to the physical use requirements of these specifications after testing.</p> <p>Scratches, color and other appearance items shall depend on the specifications of the manufacturer for each module and are not a basis for evaluation here.</p>	<p>Test Condition 85°C for 96 hours minimum. All voltage inputs = manufacturer specified.</p>

6.1.6 Low Operating Temperature

STANDARD	TESTING
<p>Module to function as specified after test and all non-volatile memory to retain the data stored prior to test.</p> <p>The form and dimensions must conform to the physical use requirements of these specifications after testing.</p> <p>Scratches, color and other appearance items shall depend on the specifications of the manufacturer for each module and are not a basis for evaluation here.</p>	<p>Test Condition -40°C for 96 hours minimum. All voltage inputs = manufacturer specified.</p>

This document is the property of and embodies CONFIDENTIAL and PROPRIETARY information of FCI Electronics. No part of the information shown on this document may be used in any way without the written consent of FCI Electronics.

	TYPE PRODUCT SPECIFICATION	NUMBER GS-12-292	
	TITLE ExpressCard Module Card Kit	PAGE 8 of 14	REVISION C
AUTHORIZED BY SH MIAO		DATE 2011-05-29	
CLASSIFICATION UNRESTRICTED			

6.1.7 Thermal Shock

STANDARD	TESTING		
Module to function as specified after test and all non-volatile memory to retain the data stored prior to test. The form and dimensions must conform to the physical use requirements of these specifications after testing. Scratches, color and other appearance items shall depend on the specifications of the manufacturer for each module and are not a basis for evaluation here.	Test	Temp(°C)	Time
	1	-40	30
	2	25	<05
	3	85	30
	4	25	<05
Repeat for 100 cycles, all voltage inputs=0 Module connector disengaged Time in minutes			

6.1.8 Moisture Resistance

STANDARD	TESTING
Module to function as specified after test and all non-volatile memory to retain the data stored prior to test. The form and dimensions must conform to the physical use requirements of these specifications after testing. Scratches, color and other appearance items shall depend on the specifications of the manufacturer for each module and are not a basis for evaluation here.	Maximum Temperature 55 °C. Minimum temperature 0 °C Steps 7a and 7b deleted from Method 106E MIL-STD 202. Repeat test for 10 cycles (excluding vibration) All voltage inputs = manufacturer specified, module connector disengaged.

6.2 Mechanical Performance:

Since FCI only manufactures the module card kit without PCB, for this reason, this FCI specification will only cover the performance of the “empty” card kit, except for vibration, bend, torque and shock tests. It is, in this area, different from the ExpressCard Standard and PC Card Standard.

6.2.1 Test Sequence:

The following table defines the recommended test sequence, each test group contains a number of tests to be executed on the test samples, each test group consists of 4 card kits minimum.

Test Item	Ref. Para.	Test Groups				
		A	B	C	D	E
Vibration	6.2.2	1				
Shock	6.2.3	2				
Bend Test	6.2.4		1			
Torque Test	6.2.5			1		
Drop Test	6.2.6				1	

This document is the property of and embodies CONFIDENTIAL and PROPRIETARY information of FCI Electronics. No part of the information shown on this document may be used in any way without the written consent of FCI Electronics.

	TYPE	PRODUCT SPECIFICATION		NUMBER	GS-12-292	
	TITLE	ExpressCard Module Card Kit			PAGE	9 of 14
				AUTHORIZED BY	SH MIAO	
				DATE	2011-05-29	
				CLASSIFICATION	UNRESTRICTED	

Contact Resistance	6.3.1					1,3
Life Cycle Testing in Office Environment	6.3.2					2

6.2.2 Vibration and High Frequency:

The card kit shall be fully functional, ie the PCB and its components shall be installed inside.

Condition:

- 147 m/s² (15G) peak amplitude, 10 to 2000 Hz, 20 minutes sweep.
- 12 cycles per axis, 3 axes. Sinusoidal signal. Total test time: 12 hours.

Requirement:

- No visual damage shall be present on the parts.
- The card shields shall still be connected mechanically.
- Module to function as specified after test and all to retain the data stored prior to test (If active PCB available).

6.2.3 Shock:

The card kit shall be fully assembled, ie the PCB (at least dummy) shall be installed inside.

Condition:

- 490 m/s² (50G) acceleration, duration: 11 ms, semi-sine wave.
- Velocity change: 3.44 m/s (11.3 ft/s). One shock to perform in vertical axis.

Requirement:

- No visual damage shall be present on the parts.
- The card shields shall still be connected mechanically.
- Module to function as specified after test and all to retain the data stored prior to test (If active PCB available)

	TYPE PRODUCT SPECIFICATION	NUMBER GS-12-292	
	TITLE ExpressCard Module Card Kit	PAGE 10 of 14	REVISION C
AUTHORIZED BY SH MIAO		DATE 2011-05-29	
CLASSIFICATION UNRESTRICTED			

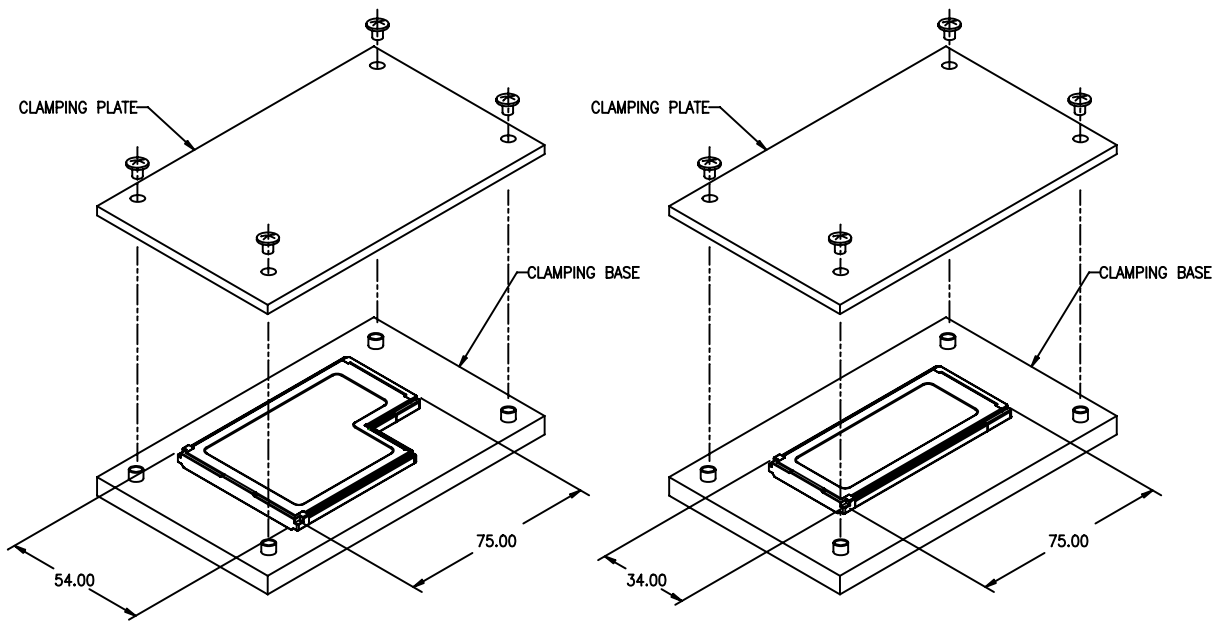

Figure for Vibration and Shock Test

6.2.4 Bend Test:

The card kit shall be fully assembled, ie the PCB (at least dummy) shall be installed inside.

Condition:

- Clamp the connector end of the module card kit. Apply 9.8 N with the force bar at the unclamped end and hold for 1 minute.
- Clamp the non-connector end of the module card kit. Apply 9.8 N with the force bar at the unclamped end and hold for 1 minute.
- Turn the module card kit upside down. Clamp the connector end of the module card kit, apply 9.8 N with the force bar at the unclamped end and hold for 1 minute.
- Clamp the non-connector end of the module card kit. Apply 9.8 N with the force bar at the unclamped end and hold for 1 minute.

This document is the property of and embodies CONFIDENTIAL and PROPRIETARY information of FCI Electronics. No part of the information shown on this document may be used in any way without the written consent of FCI Electronics.

	TYPE PRODUCT SPECIFICATION	NUMBER GS-12-292	
	TITLE ExpressCard Module Card Kit	PAGE 11 of 14	REVISION C
AUTHORIZED BY SH MIAO		DATE 2011-05-29	
CLASSIFICATION UNRESTRICTED			

Total test must include all four (4) procedures.

Requirement:

- No visual damage shall be present on the parts.
- The card shields shall still be connected mechanically.
- Module to function as specified after test and all to retain the data stored prior to test (If active PCB available).
- The dimensions must conform to the use requirements of these specifications after testing.
- Cosmetic irregularities like scratches, dents, spots, finger prints are not a basis for evaluation here

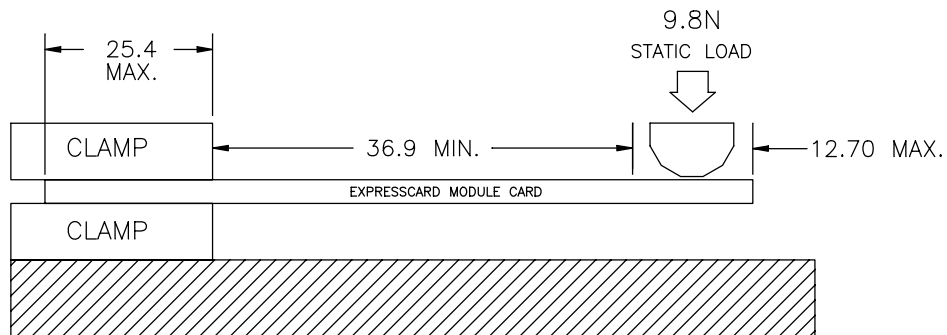

Figure for Bend Test

6.2.5 Torque Test:

The card kit shall be fully assembled, ie the PCB (at least dummy) shall be installed inside.

Condition:

- Clamp one end of the module card kit. Apply clockwise torque to the unsupported end of the module card kit, (torque=0.618 N-m maximum or angle=5 ° maximum, whichever occurs first), and hold for 5 minutes.

This document is the property of and embodies CONFIDENTIAL and PROPRIETARY information of FCI Electronics. No part of the information shown on this document may be used in any way without the written consent of FCI Electronics.

	TYPE PRODUCT SPECIFICATION	NUMBER GS-12-292	
	TITLE ExpressCard Module Card Kit	PAGE 12 of 14	REVISION C
AUTHORIZED BY SH MIAO		DATE 2011-05-29	
CLASSIFICATION UNRESTRICTED			

- Repeat test applying counter-clockwise torque.
- Repeat test five (5) times in each direction.

Requirement:

- No visual damage shall be present on the parts.
- The card shields shall still be connected mechanically.
- Module to function as specified after test and all to retain the data stored prior to test (If active PCB available).
- The dimensions must conform to the use requirements of these specifications after testing.
- Cosmetic irregularities like scratches, dents, spots, finger prints are not a basis for evaluation here.

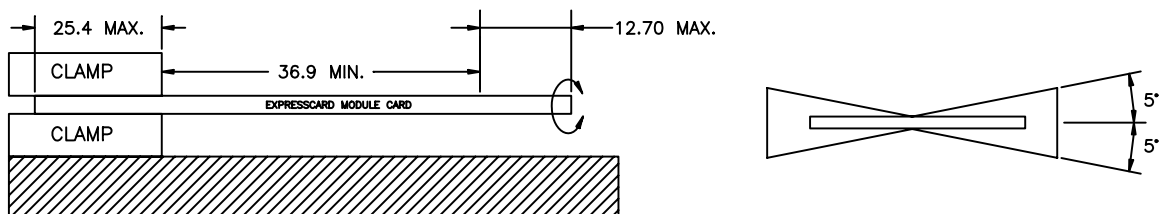

Figure for Torque Test

6.2.6 Drop Test:

The card kit shall be fully assembled, ie the PCB (at least dummy) shall be installed inside.

Condition: Drop module two (2) times in three (3) mutually exclusive axes: X, Y, and Z, from a height of 75 cm onto a non-cushioning, vinyl-tile surface.

Requirement:

- No visual damage shall be present on the parts.
- The card shields shall still be connected mechanically.
- Module to function as specified after test and all to retain the data stored prior to test (If active PCB available).

This document is the property of and embodies CONFIDENTIAL and PROPRIETARY information of FCI Electronics. No part of the information shown on this document may be used in any way without the written consent of FCI Electronics.

	TYPE PRODUCT SPECIFICATION	NUMBER GS-12-292	
TITLE ExpressCard Module Card Kit		PAGE 13 of 14	REVISION C
		AUTHORIZED BY SH MIAO	DATE 2011-05-29
CLASSIFICATION UNRESTRICTED			

- Cosmetic irregularities like scratches, dents, spots, finger prints are not a basis for evaluation here.

6.3 Electrical Performance:

6.3.1 Contact Resistance between module card kit and ground:

The ground contacts of the host socket chassis make a direct contact with the stainless steel card shields. The grounding requirement defines the contact resistance between the module card kit ground clip area and the host socket chassis attachment point.

Condition: Solder a 26 position SMT receptacle on a dummy PCB, and assemble it in two card shields. Measure and record the initial contact resistance (40 mΩ max) in 4 different points on 26 position SMT receptacle and also in 4 different points of the card shields.

Test condition: open circuit voltage equals 20mV, test current equals 100 mA maximum.

Requirement: After test, measure and record the final (after stress) contact resistance, 55 mΩ max. (allowable resistance change: 15 mΩ).

6.3.2 Life Cycle Testing in Office Environment:

Mate and un-mate the module card kit into the host socket chassis for a total of 10000 cycles at the rate of 400-600 cycles per hour (1 cycle=1 insertion + 1 extraction).

6.3.3 Electrostatic Discharge:

As this specification does not include the electrical circuits within the module card kit, it is not possible to specify any requirement.

FCI can only state that our module card kit can contribute to the ESD performance of the customer's end product, as the module card kit contains 2 stainless steel card shields which directly transfer the electrostatic load to the host socket chassis.

6.3.4 Electromagnetic Field Interference:

As this specification does not include the electrical circuits within the module card kit, it is not possible to specify any requirement.

FCI can only state that our module card kit can contribute to the electromagnetic field interference performance of the customer's end product, as the module card kit contains 2 stainless steel card shields which have a shielding effect.

6.3.5 Insulator:

An electrical insulator is available as an option.

The insulator thickness is 0.10 mm maximum. It has a dielectric withstanding voltage of 2500V.

This document is the property of and embodies CONFIDENTIAL and PROPRIETARY information of FCI Electronics. No part of the information shown on this document may be used in any way without the written consent of FCI Electronics.

	TYPE PRODUCT SPECIFICATION	NUMBER GS-12-292	
TITLE ExpressCard Module Card Kit		PAGE 15 of 14	REVISION C
		AUTHORIZED BY SH MIAO	DATE 2011-05-29
CLASSIFICATION UNRESTRICTED			

This document is the property of and embodies CONFIDENTIAL and PROPRIETARY information of FCI Electronics. No part of the information shown on this document may be used in any way without the written consent of FCI Electronics.

Form E-3005
 Rev A 02/12/01
 V20603

GS-01-001