

| | | |
|--|--|---------------------------------|
|  Connector Systems Division | Quickie DIL PCB Connector Product Specification | デュポン ジャパン リミテッド コネクタ システム事業部 |
|--|--|---------------------------------|

1. Scope

This specification is intended to cover the performance and evaluation conditions of Quickie DIL PCB connector.

2. Applicable P/Ns

This specification is applied to the products listed in Table 2.1.

Table 2.1

| Name | No. of pos. | P/N | Remarks |
|---------------------------|-------------|------------------------|--|
| Quickie DIL PCB Connector | 2 x 3 | 68120-006 69830-006 | Terminal: phos bro. Finish: tin-lead Hsg: PET glass 30 % |
| | 2 x 4 | -008 | |
| | 2 x 5 | -010 | |
| | 2 x 7 | -014 | |
| | 2 x 8 | -016 | |
| | 2 x 10 | -020 | |
| | 2 x 12 | -024 | |
| | 2 x 13 | -026 | |
| | 2 x 17 | -034 | |
| | 2 x 20 | -040 | |
| | 2 x 25 | -050 | |
| | 2 x 30 | -060 | |
| Quickie DIL PCB Connector | 2 x 32 | 68120-064 69830-064 | Terminal: phos bro. Finish: tin-lead Hsg: PET glass 30% |

| | | | | | | |
|------|----------------|----------|-----|--|-----------|------|
| | | | | PREP'D BY: <i>H. Sakamoto</i> 6-27-84 | NO: | REV. |
| B | Revised J20139 | 4/22/92 | M.Y | ISS'D BY: <i>H. Sakamoto</i> 6-27-84 | 110 - 019 | B |
| A | Prepared | 11/30/84 | HS | APPR. BY: <i>J. Ito</i> 6-27-84 | | |
| REV. | CONTENTS | DATE | BY | | | |

3. Applicable Cable

Applicable cables are listed in table 3.3.

Table 3.3

| Name | P/N | Wire Size | Remarks |
|---------------------|-------|-----------------|------------|
| Flexible Flat Cable | 67001 | AWG #28 7/0.127 | Tin plated |
| Flexible Flat Cable | 65088 | AWG #28 7/0.127 | Tin plated |
| Flexible Flat Cable | 76164 | AWG #28 7/0.127 | Tin plated |
| Flexible Flat Cable | 76167 | AWG #30 1/0.254 | --- |
| Flexible Flat Cable | 76177 | AWG #28 7/0.127 | Tin plated |

Note 1. Cable application must be complied with IDC spec No. 100-004

4. Material and Finish

4.1 Metal parts

(1) Terminal---Phospher Bronze. Tin-lead plating of a minimum of 3.8 micron m thick.

(2) Strain relief---Stainless steel

4.2 Plastic parts

(1) Base and Cover---PET glass 30% filled UL 94V-0

5. Structure

This connector shall be of one-piece design, consisting of terminals, base, cover, and strain relief (optional). The locking latch consisting of cover and base makes cable assembly easy. Each terminal is having a latching mechanism fixing both cover and base. (See Fig. 5.)

NO:

110 - 019

REV.

B

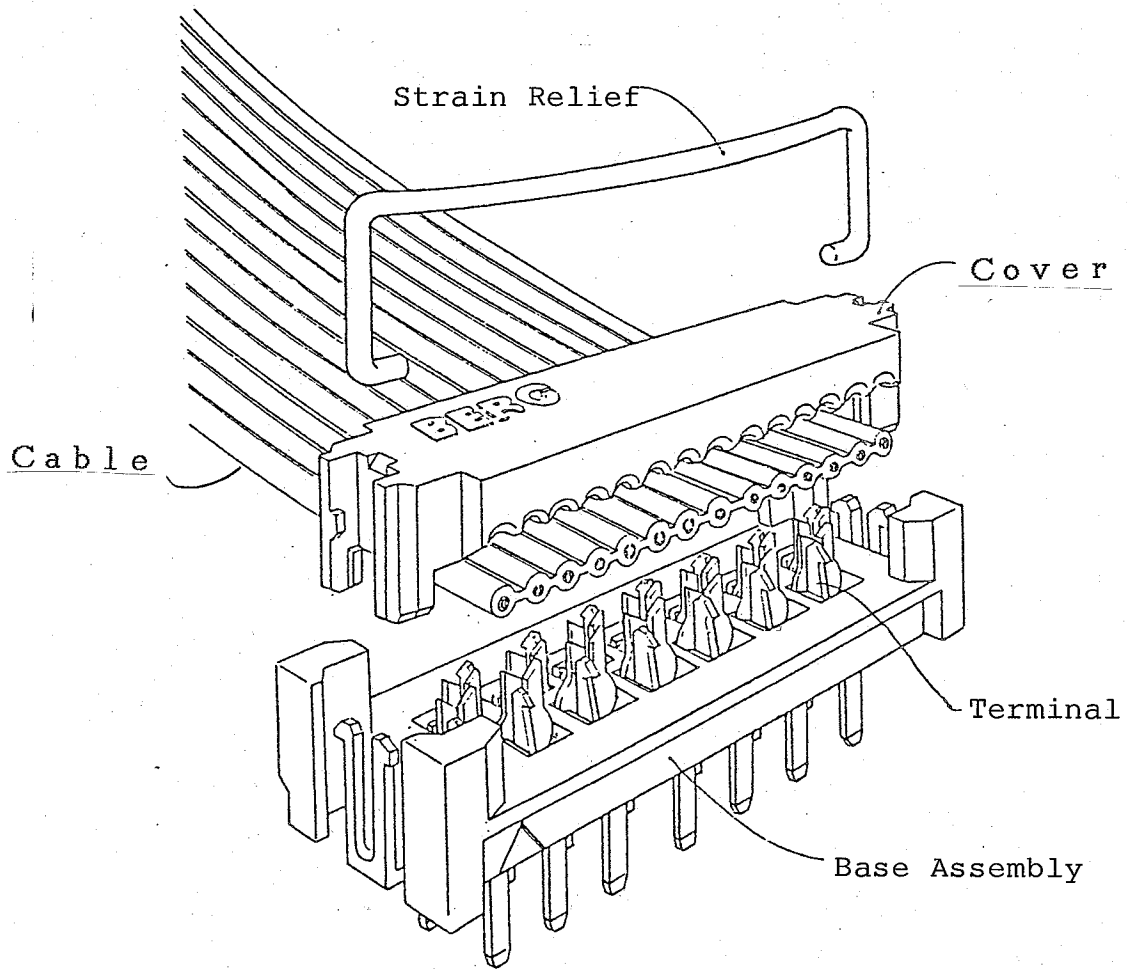

Fig. 5. Structure of Connector

| | |
|-----------|------|
| NO: | REV. |
| 110 - 019 | B |

6. Performance

When tested under the ambient conditions of JIS-C5020 as described below and evaluated with the sequence listed in table 6.3, the connector shall meet the requirements in 6.1, unless otherwise specified.

Connectors subjected to following tests shall be uniform in quality and shall be free from burrs, scratches, cracks, voids, chips, blisters, pin holes, sharp edges, and other defect that adversely affect life or service ability.

The ambient condition:

- Temperature 5 - 35 °c
- Related humidity 45 - 85%
- Atmospheric pressure . . . 860 - 1060 mb

6.1 Performance requirements

6.1.1 Electrical

- (1) Rated current---1 Adc
- (2) Contact resistance---The contact resistance shall not exceed 10 or 20 milliohms respectively before or after any environmental exposure when measured as described in 7.1.
- (3) Contact resistance (Low level)---The contact resistance (Low level) shall not exceed 10 or 20 milliohms respectively before or after any environmental exposure when measured as described in 7.2.
- (4) Insulation resistance---The insulation resistance shall be not less than 100 megohms when measured as described in 7.3.
- (5) Dielectric withstanding voltage---There shall be no evidence of arc-over or insulation breakdown or excessive leak current (>1 milliamper) when measured as described in 7.4.
- (6) Temperature rise---The temperature rise shall not exceed 30 deg. when measured using thermocouple as described in 7.5.

| | |
|--------------------|---------------|
| NO: 110-019 | REV. B |
|--------------------|---------------|

6.1.2 Environmental

- (1) Humidity---There shall be no evidence of cracking swelling or oxidation which would be detrimental to the function of the connector and the contact resistance shall not exceed 20 milliohms when tested as described in 7.6.
- (2) Salt spray---There shall be no evidence of cracking, swelling or oxidation which would be detrimental to the function of the connector, and the contact resistance shall not exceed 20 milliohms when tested as described in 7.7.
- (3) Thermal shock---There shall be no evidence of cracking, swelling or other damage which would be detrimental to the function of the connector. The contact resistance shall not exceed 20 milliohms when tested as described in 7.8.
- (4) High temperature life---After exposure of the connectors without cable to a high temperature operating environment, the insulation resistance of an unterminated connector shall be less than 100 megohms; the contact resistance of a terminated connector shall not exceed 20 milliohms when tested as described in 7.9.
- (5) Shock---There shall be no evidence of physical or mechanical damage which would be detrimental to the function of the connector, and during and after each shock, the contacts shall evidence no discontinuity greater than 1 microsecond when tested as described in 7.10.
- (6) Vibration---There shall be no evidence of physical or mechanical damage or disassociation of parts, and the contacts shall evidence no discontinuity greater than 1 microsecond when tested as described in 7.11.
- (7) Hydrogen sulfide exposure---After exposure of the connectors to an H₂S atmosphere, the low level contact resistance shall not exceed 20 milliohms when tested as described in 7.12.
- (8) Solderability---No less than 90% of the dipped surface of the pin shall be wet when tested as described in 7.13.
- (9) Solder-heat resistance---There shall be no physical damage detrimental to connector functions when tested as described in 7.14.

NO:

110 - 019

REV.

B

6.1.3 Mechanical

- (1) Appearance---There shall be no evidence of cracking, selling, oxidation or anything which would be detrimental to the function of the connector when tested as described in 7.15.
- (2) Cable retention---The strain relief on the connector shall withstand the fixed force listed below for 30 minutes when tested as described in 7.16.

| P/N | fixed force (kg) |
|------------------|------------------|
| 68120, 69830-006 | 2.04 |
| ↑ -008 | 2.72 |
| -010 | 3.4 |
| -014 | 4.7 |
| -016 | 5.44 |
| -020 | 6.8 |
| -024 | 8.16 |
| -026 | 8.84 |
| -028 | 10 |
| -034 | 10 |
| -040 | 10 |
| -050 | 10 |
| ↓ -060 | 10 |
| 68120, 69830-064 | 10 |

- (3) Cable flex resistance---With strain relife installed, the contact resistance shall not exceed 20 milliohms when tested as described in 7.17.

6.2 Sample

Table 6.2 Sample

| Test Group | Flexible Flat Cable |
|------------|--|
| 1 | AWG #28 (7/φ0.127) AWG #30 (1/φ0.254) |
| 2 | " |
| 3 | —#— |
| 4 | AWG #28 (7/φ0.127) |
| 5 | " |
| 6 | —#— |
| 7 | —#— |
| 8 | AWG #28 (7/φ0.127) |
| 9 | AWG #30 (1/φ0.254) |

| | |
|-----------|------|
| NO: | REV. |
| 110 - 019 | B |

6.3 Test Sequence

| Item | | Test Sequence | | | | | | | | |
|---|------|----------------|----------|-------------|---------------------|---------------------|-----|-----|-----|-----|
| | | Test Group No. | | | | | | | | |
| | | 1 | 2 | 3 | 4 | 5 | 6 | 7 | 8 | 9 |
| 1 Contact Resistance | 7.1 | | | | | | | | 3,6 | 3,6 |
| 2 Contact Resistance (Low Level Circuit) | 7.2 | 2,4 6,8 | 2,4 6 | | 2,4 6,8 10,12 | 2,4 6,8 10,12 | | | 2,5 | 2,5 |
| 3 Insulation Resistnace | 7.3 | | | 2,5 8,11 | | | | | | |
| 4 Dielectric With- standing Voltage | 7.4 | | | 3,6 9,12 | | | | | | |
| 5 Temperature Rise | 7.5 | | | | | | | | 4 | 4 |
| 6 Humidity | 7.6 | 5 | 3 | 7 | | | | | | |
| 7 Salt Spray | 7.7 | | | | 11 | 11 | | | | |
| 8 Thermal Shock | 7.8 | 3 | | 4 | | | | | | |
| 9 High Temperature Life | 7.9 | 7 | 5 | 10 | | | | | | |
| 10 Shock | 7.10 | | | | 5 | 5 | | | | |
| 11 Vibration | 7.11 | | | | 7 | 7 | | | | |
| 12 Hydrogen Sulfide Exposure | 7.12 | | | | 9 | 9 | | | | |
| 13 Solderability | 7.13 | | | | | | 2 | | | |
| 14 Solder-Heat Resistance | 7.14 | | | | | | | 2 | | |
| 15 Appearance | 7.15 | 1,9 | 1,7 | 1,13 | 1,13 | 1,13 | 1,3 | 1,3 | 1,7 | 1,7 |
| 16 Cable Retension | 7.16 | | | | | 3 | | | | |
| 17 Cable Flex Resistance | 7.17 | | | | 3 | | | | | |

NO:

110 - 019

REV.

B

7. Test Methods

7.1 Contact Resistance

The contact resistance is defined as an electrical resistance to include I.D.C. portion and part of terminal at shown in Fig. 1. and measurement shall be done with current of 1A (rated current).

7.2 Contact Resistance (Low Level Circuit)

The contact resistance (low level circuit) is defined as an electrical resistance to include I.D.C. portion and part of terminal shown in Fig. 1. and measurement shall be done with current of 10 mA max and open circuit voltage of 20 mV max.

7.3 Insulation Resistance

The connector shall not be terminated with flexible flat cable and shall not be plugged in a pc board. DC 500 V shall be applied for the period of one minute between adjacent contact position according to MIL-STD-202, Method 302.

7.4 Dielectric Withstanding Voltage

The connector shall not be terminated with flexible flat Cable and shall not be plugged in a pc board. AC 750 V shall be applied for the period of one minute between adjacent contact position according to MIL-STD-202, Method 301.

7.5 Temperature Rise

The connector shall be wired in series before the current of DC 1A is applied. The temperature rise shall be measured using a thermocouple at near I.D.C. portion of terminal located at or near the middle of the connector where the temperature is expected to rise to the highest.

7.6 Humidity

The connector shall be left for 96 hours in an environment of $40 \pm 2^{\circ}\text{C}$, and 90 - 95% humidity. After the exposure the connector shall be left in an ambient condition for one hour before the measurement is done. The testing shall be in accordance with MIL-STD-202, Method 103-B.

| | |
|-----------|------|
| NO: | REV. |
| 110 - 019 | B |

7.7 Salt Spray

The connector shall be exposed to 5% salt fog for 48 hours at 35°C. Then the connector shall be mildly rinsed in running water to remove the deposition of salt, followed by natural drying by placing it for 24 hours at room temperature. The testing shall be in accordance with MIL-STD-202, Method 101-B.

7.8 Thermal Shock

The connector shall be exposed five cycles to the temperature extremes of -55°C for 30 minutes followed by 85°C for 30 minutes. The testing shall be in accordance with MIL-STD-202, Method 107-A.

7.9 High Temperature Life

The connector shall be exposed to the ambient of following condition. The testing shall be in accordance with MIL-STD-202, Method 108.

- (a) Test Chamber Temperature -85°C
- (b) Test Condition (duration) - B(250 hours)
- (c) Operating Condition - 1.0 A DC (rated) through all contacts of terminated connector; duty cycle:
45 minutes ON and 15 minutes OFF.

7.10 Shock

The connector shall be subjected to following transient accelerations. The testing shall be in accordance with MIL-STD-202, Method 213.

- 1) Test Condition - 100 G, 6 ms sawtooth
- 2) Number of Shocks - 3 Shocks in each direction along three orthogonal axes (18 total).
- 3) Mounting - See figure 7.2.

| NO: | REV. |
|-----------|------|
| 110 - 019 | B |

7.11 Vibration

The connector shall be subjected to following prolonged mechanical condition. The testing shall be in accordance with MIL-STD-202, Method 204.

- 1) Test Condition - ± 15 G, 10~2000 Hz
- 2) Test Duration - 4 hours along each of three orthogonal axes (12 hours total)
- 3) Mounting - See Figure 7.2.

7.12 Hydrogen Sulfide (H₂S) Exposure

The connector shall be exposed to an H₂S atmosphere. The following details shall be applied.

- 1) Test Density - H₂S 10 ± 5 PPM
- 2) Test Temperature - 40°C
- 3) Test Duration - 48 hours
- 4) Test Humidity - 80%

7.13 Solderability

The terminal tips of the connector shall be immersed for 5 to 10 seconds in the flux (alpha 100, GX-5, or GX-7), and then be dipped in a solder bath of tin-60% and lead-40% at 230 °C ± 0.5 for 3 ± 0.5 seconds. The test shall be in accordance with MIL-STD-202, Method 208.

7.14 Solder-Heat Resistance

The connector shall be plugged in a pc board. The end of the terminal coming through the board shall be dipped in a solder bath at 260 ± 5 °C for 5 ± 0.5 seconds.

7.15 Appearance

The connector shall be free from burrs, scratches, cracks, voids, chips, blisters, pinholes, sharp edges, and other defects that will adversely affect life or service ability.

7.16 Cable Retension

With strain relief installed, the fixed force shall be applied to the cable in a direction parallel to the contact axis for 30 minutes. See Fig. 7.3.

| | |
|-----------|------|
| NO: | REV. |
| 110 - 019 | B |

7.17 Cable Flex Resistance

With strain relief installed, the 100 cycles of cable flexing shall be applied to the cable with following details.

- 1) Tension - 0.9 kg per 25.4 mm cable width.
- 2) Flex Angle - 140° as show in Figure 7.4.
- 3) Applicable cable - Stranded wire only.

| | |
|-----------|------|
| NO: | REV. |
| 110 - 019 | B |

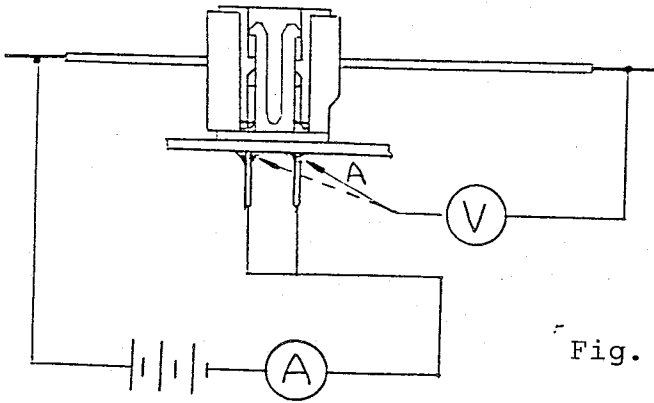

Fig. 7.1 Contact Resistance

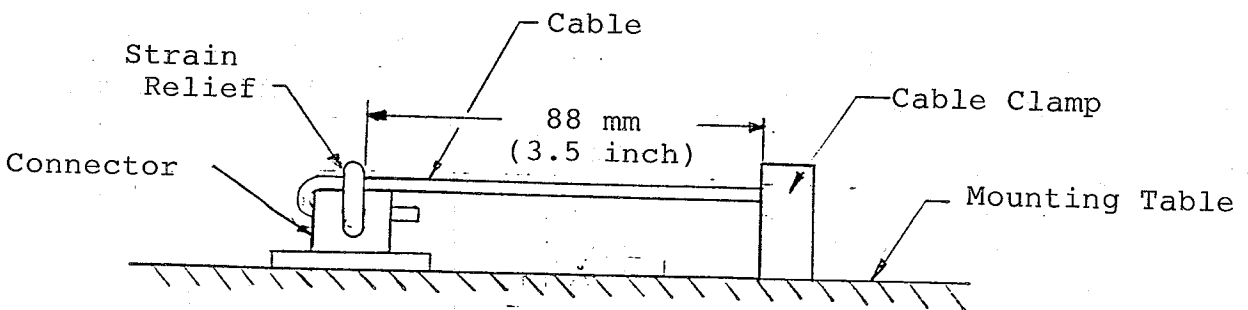

Fig. 7.2 Shock and Vibration Test

| | |
|-----------|----|
| NO: | 改訂 |
| 110 - 019 | B |

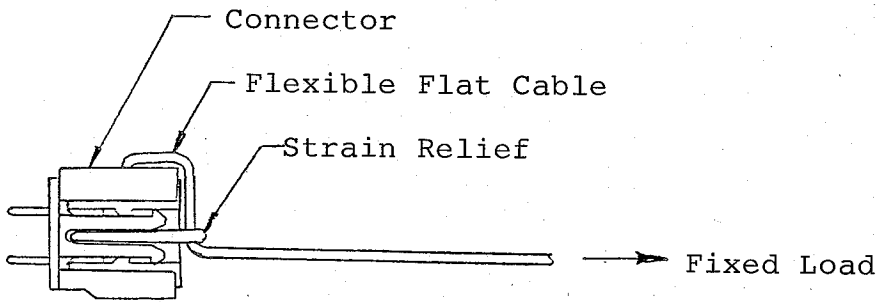

Fig. 7.3 Cable Retention

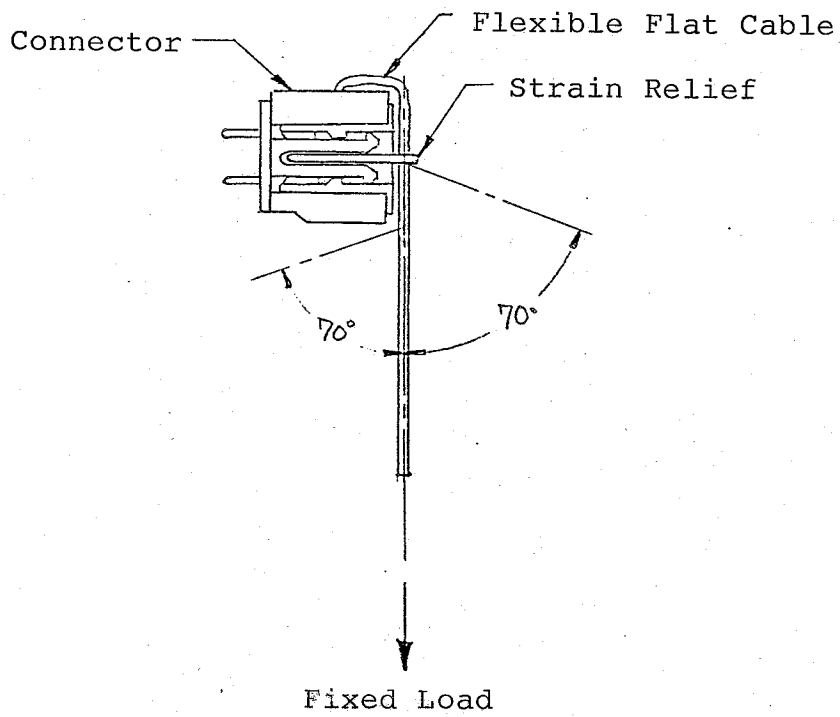

Fig. 7.4 Cable Flex Resistance

| | |
|-----------|------|
| NO: | REV. |
| 110 - 019 | B |

8. Applicable Documents

8.1 MIL-STD-202

Test Methods for Electronic and Electrical Component parts.

8.2 BUS-10-001 Round Conductor (Solid & Stranded) Flat Flexible Cable

| | |
|----------------------|---------------|
| NO: 110 - 019 | REV. B |
|----------------------|---------------|